

600mA PWM Configurable Front Flash LED Driver

FEATURES

- Front Flash LED Driving
- 600mA Maximum Flash Current
- PWM Dimming Input
- Flash Timeout Protection: 1.2s
- LED Current Accuracy: $\pm 8\%$
- Low Dropout Voltage: 140mV@600mA (Typ.)
- Efficiency: 94% ($V_{IN}=3.6V$, $V_F=3.4V$)
- LED Short Protection
- Under Voltage Lock Out (UVLO)
- Over Thermal Protection(OTP)
- Ultra Small 1.5mm×1.5mm DFN-8 Package
- Compatible with AW36404

APPLICATIONS

Cell Phone

GENERAL DESCRIPTION

The AW36406 is a low voltage-drop current sink LED driver, which supports both flash and torch modes. The current-regulation sink integrated in the chip makes the LED current be capable of keeping constant when input voltage, LED forward voltage or temperature are changing. The LED current can be adjusted by PWM signal into the EN pin, and the maximum value is 600mA.

The AW36406 is available in an ultra-small 1.5mm× 1.5mm×0.55mm DFN-8 package. And only one multi-layer ceramic capacitor is needed for the peripheral of the solution.

In shut down mode, the AW36406 turns off all internal circuit and the consumption is less than 1 μ A.

The device requires 2.7V~5.5V input voltage range and an operating temperature range of -40 ~ 85 $^{\circ}$ C.

TYPICAL APPLICATION CIRCUIT

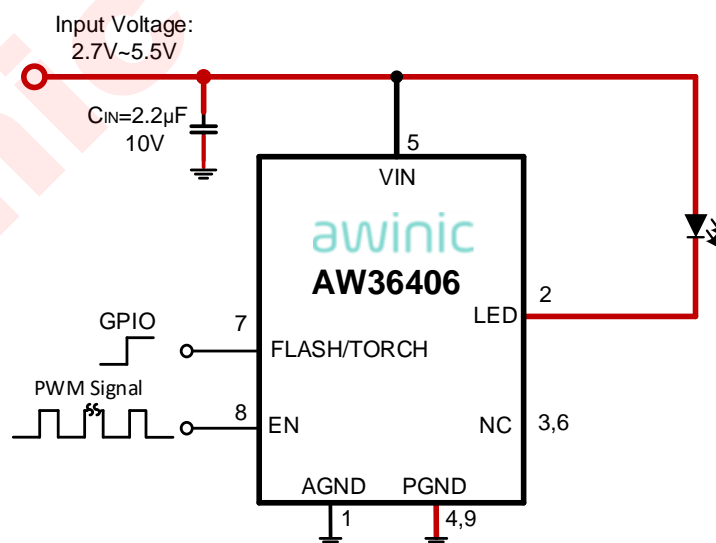
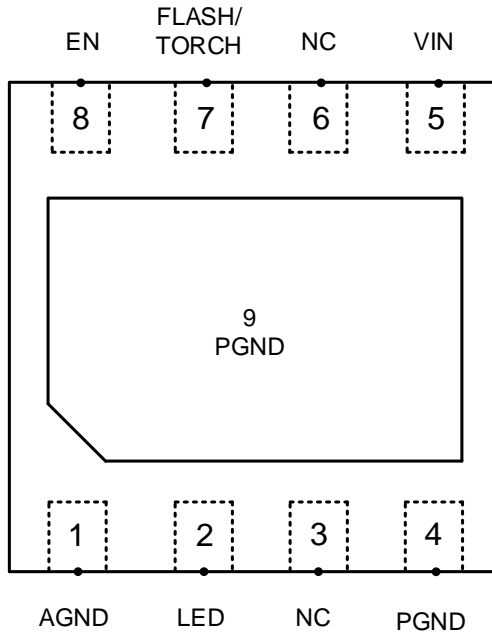
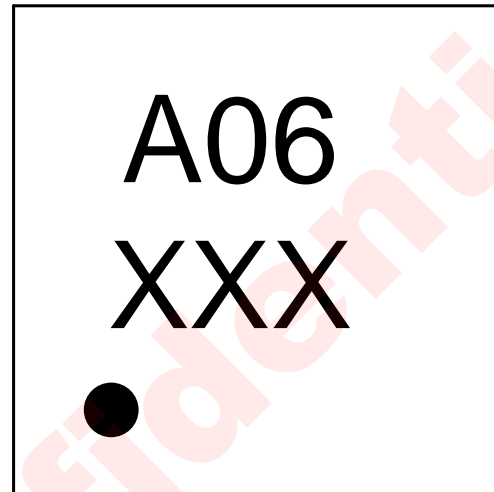

Figure 1. The AW36406 Application Circuit for Single LED

PIN CONFIGURATION AND TOP MARK

AW36406DNR Pin Configuration
(Top View)AW36406DNR Marking
(Top View)

A06 ---- AW36406DNR
XXX ---- Production Tracking Code

Figure 2. The AW36406 Pin Configuration and Top Mark

PIN DEFINITION

No.	NAME	TYPE	DESCRIPTION
1	AGND	Ground	Analog Ground.
2	LED	I/O	Low-Side Current Sink Output For LED.
3	NC	I/O	No Connect.
4	PGND	Ground	Power Ground.
5	VIN	Power	Power Supply (2.7V-5.5V).
6	NC	I/O	No Connect.
7	FLASH/TORCH	I/O	Flash/Torch Mode Setting: FLASH/TORCH="H", Flash Mode; FLASH/TORCH="L", Torch Mode;
8	EN	I/O	Enable Pin. LED Current Can Be Adjusted By Sending PWM Signal Into This Pin.
9	PGND	Ground	Power Ground.

ORDERING INFORMATION

Part Number	Temperature	Package	Marking	Moisture Sensitivity Level	Environmental Information	Delivery Form
AW36406DNR	-40°C~85°C	DFN-8 1.5mm*1.5mm	A06 XXX	MSL1	ROHS+HF	3000 units/ Tape and Reel

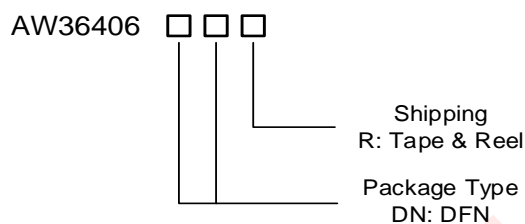

AWINIC FLASH LED DRIVER SERIES

Product	Channels	Type	Description	Package
AW3644	2	Boost	High Efficiency, Dual Independent 1.5A Flash LED Driver	CSP-12
AW36414	2	Boost	High Efficiency, Dual Independent 1.5A Flash LED Driver	CSP-12
AW3643	2	Boost	High Efficiency, Dual 1.5A Flash LED Driver	CSP-12
AW36413	2	Boost	High Efficiency, Dual 1.5A Flash LED Driver	CSP-12
AW3648	1	Boost	High Efficiency, 1.5A Flash LED Driver	CSP-12
AW3641E	1	Charge Pump	Flash Current & Flash Timer Programmable 1A Flash LED Driver	DFN-10
AW3640	1	Current Sink	200mA 1-Wire Configurable Front Flash LED Driver	DFN-6
AW36402	1	Current Sink	200mA 1-Wire Configurable Front Flash LED Driver	DFN-6
AW36404	1	Current Sink	400mA 1-Wire Configurable Front Flash LED Driver	DFN-8
AW36406	1	Current Sink	600mA PWM Configurable Front Flash LED Driver	DFN-8

TYPICAL APPLICATION CIRCUIT

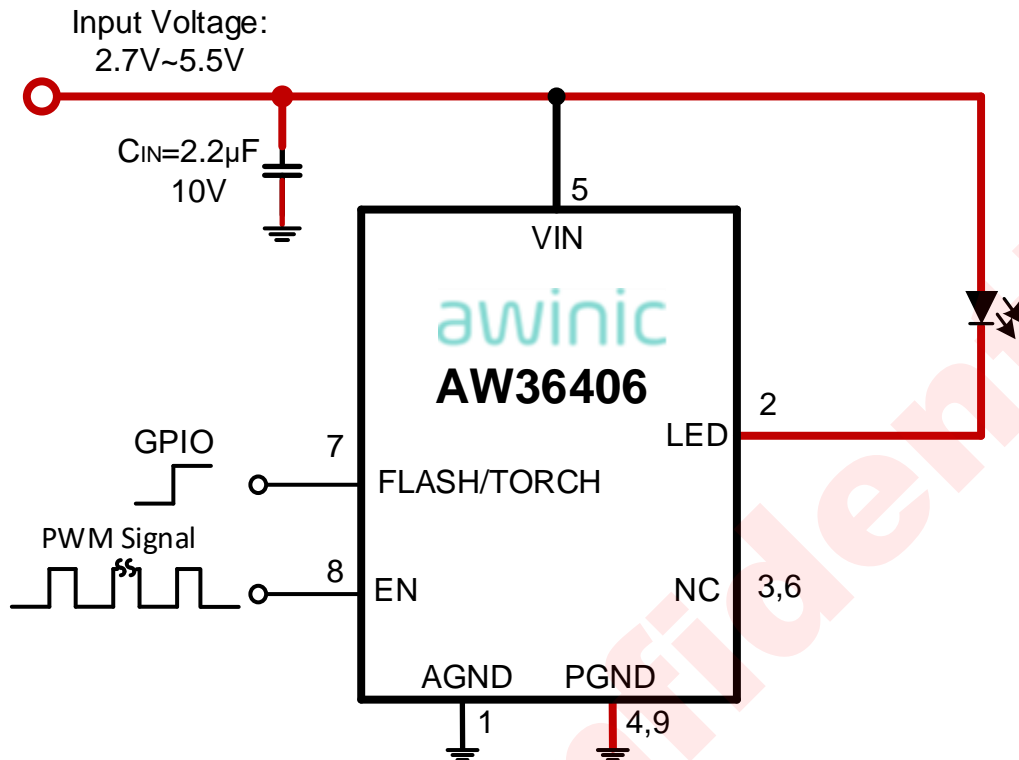

Figure 3. Application Circuit for Single LED

Notice for Typical Application Circuits:

1. C_{IN} should be close to the pin of VIN.
2. Red line is high current path. Considering driving ability, for example, the power path INPUT--VIN--LED should be as short and wide as possible.
3. For better thermal performance and noise performance, the AGND and PGND pins should be connected directly to a large area of the PCB ground plane.

ABSOLUTE MAXIMUM RATINGS^(NOTE1)

PARAMETERS		Range	Unit
VIN, LED		-0.3 to 6	V
EN		-0.3 to (VIN+0.3)	V
FLASH/TORCH		-0.3 to (VIN+0.3)	V
Max Junction Temperature T _{JMAX}		155	°C
Storage Temperature T _{STG}		-65 to 150	°C
Maximum lead temperature (soldering)		260	°C
Junction to Ambient Thermal Resistance θ_{JA}		121	°C/W
ESD, All Pins ^(NOTE2)	HBM	±2000	V
	MM	±200	V
	CDM	±2000	V
Latch-Up JEDEC STANDARD NO.78B DECEMBER 2008		+IT: +350 -IT: -350	mA

RECOMMENDED OPERATING CONDITIONS

PARAMETERS	Range	Unit
VIN	2.7 to 5.5	V
Junction temperature (T _J)	-40 to 125	°C
Ambient temperature (T _A)	-40 to 85	°C

NOTE1: Conditions out of those ranges listed in "absolute maximum ratings" may cause permanent damages to the device. In spite of the limits above, functional operation conditions of the device should within the ranges listed in "recommended operating conditions". Exposure to absolute-maximum-rated conditions for prolonged periods may affect device reliability.

NOTE2: The human body model is a 100pF capacitor discharged through a 1.5kΩ resistor into each pin. Test method: MIL-STD-883G Method 3015.7

ELECTRICAL CHARACTERISTICS

VIN=3.6V, TA=25°C for typical values (unless otherwise noted)。

Symbol	Description	Test Conditions	Min	Typ.	Max	Units
Power supply						
VIN	Input Operation Voltage		2.7		5.5	V
UVLO	Input Under Voltage Lock Out	Rising edge		2.4		V
		Falling edge	1.9	2.2	2.5	V
ISD	Current In Shutdown Mode	EN=0		0.1	1	μA
Iq	Quiescent Current	EN=1,D=100%, LED pin open		200		μA
LED Driver						
ILED	Total Output Current, Flash/Torch Mode	EN=1, D=100%	-8%	600	8%	mA
		EN=1, D=50%		300		mA
		EN=1, D=10%		60		mA
VDROP	Dropout Voltage	ILED=600mA		140	210	mV
ISHORT	LED Short Detecting Current			2.5		mA
Control						
VIL	Logic Input Low Level				0.4	V
VIH	Logic Input High Level		1.3			V
REN	Internal Pull Down Resistor of EN Pin			500		kΩ
OTP	Thermal Shutdown Threshold			155		°C
	Thermal Shutdown Hysteresis			20		°C
TFLASH	Flash Timeout Duration			1.2		s
RFLA/TOR	Internal Pull Down Resistor of FLASH/TORCH Pin			500		kΩ
TSHDN	Chip Shutdown Delay	EN pulse width to shutdown. EN high to low	2.5			ms
PWM Dimming Pulse Timing						
FPWM	Frequency		10k	20k	50k	Hz
THIGH	High Level Width of PWM		0.3			μs

TYPICAL CHARACTERISTICS

V_{IN}=3.6V, T_A=25°C , unless otherwise noted.

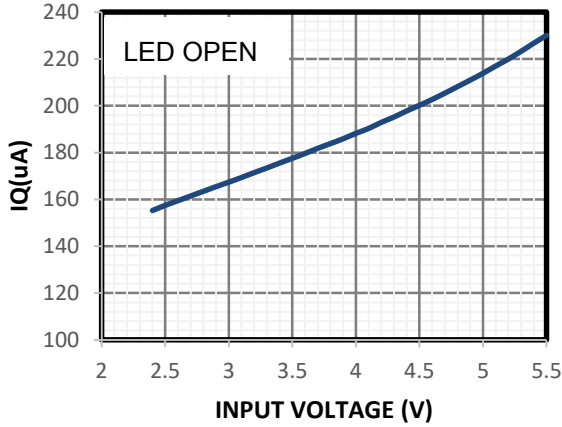

Figure 4. Quiescent Current vs Input Voltage

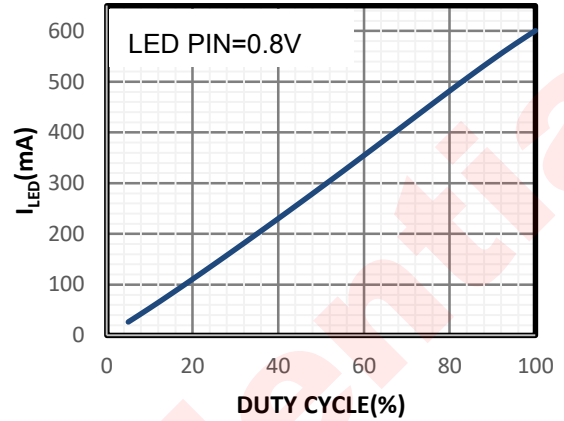

Figure 5. LED Current vs Duty Cycle

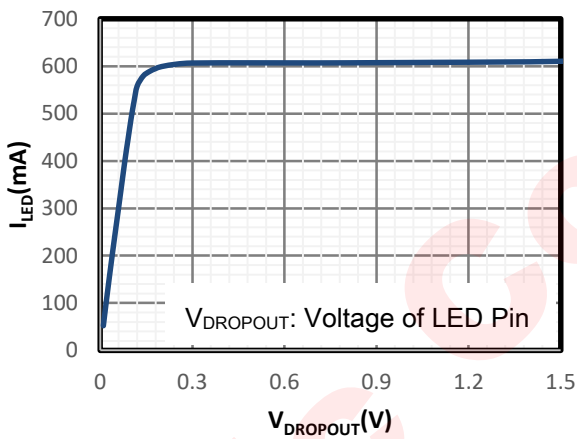

Figure 6. LED Current vs V_{LED}

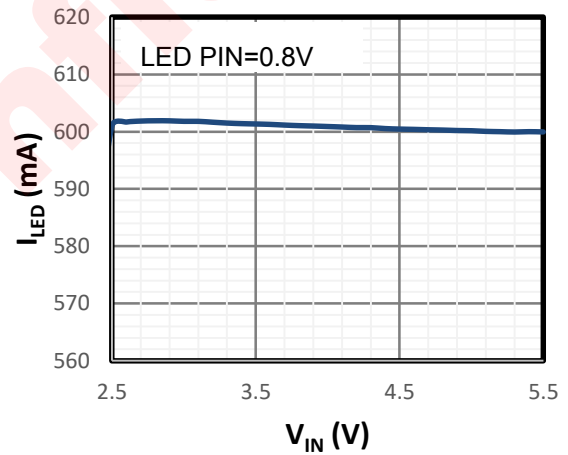
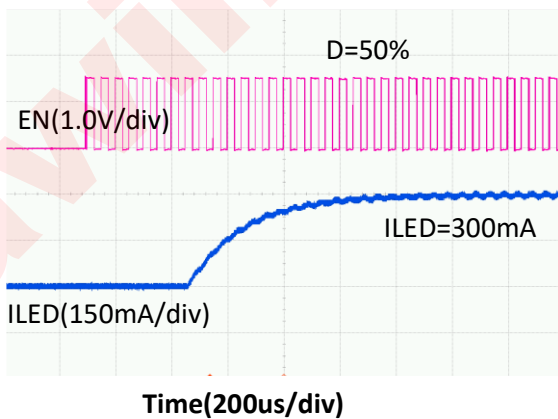
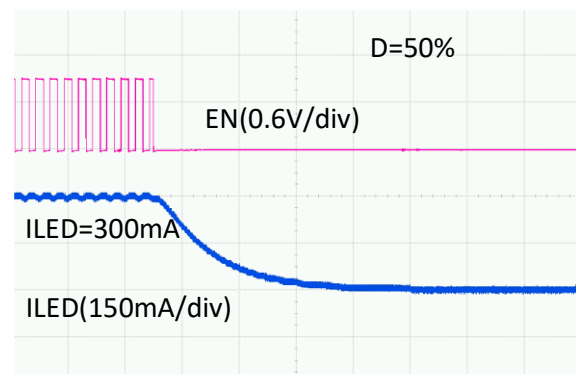

Figure 7. LED Current vs V_{IN}



Time(200us/div)

Figure 8. Startup Wave



Time(200us/div)

Figure 9. Shutdown Wave

FUNCTION BLOCK

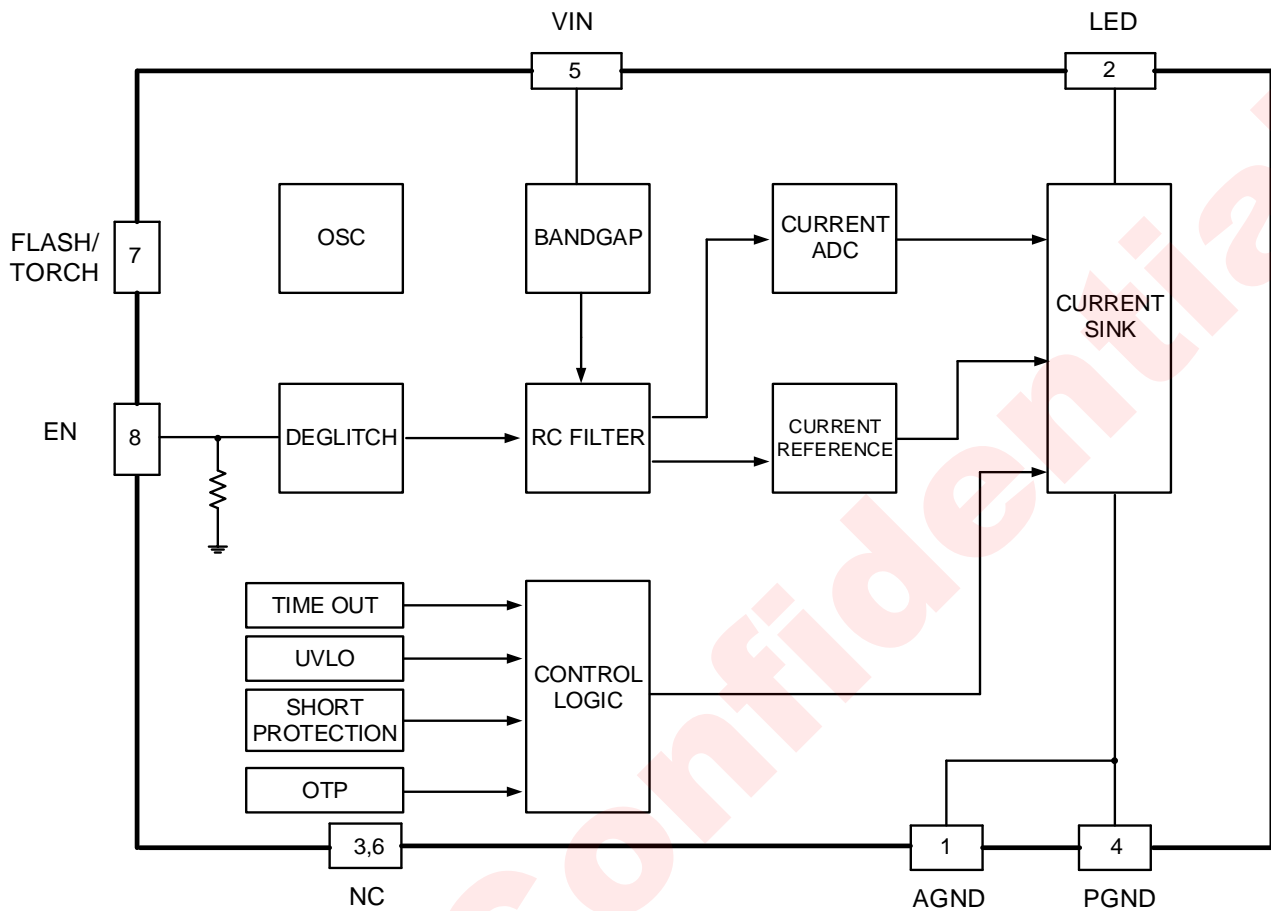

Figure 10. The AW36406 Function Block

DETAILED DESCRIPTION

The AW36406 is a low voltage-drop current sink LED driver, which supports both flash and torch modes. The current-regulation sink integrated in the chip make the LED current capable of keeping constant when input voltage, LED forward voltage or temperature are changing. The LED current can be adjusted by duty cycle of PWM signal into the EN pin, and the maximum value is 600mA.

EN Control

The voltage level at EN pin determines the operation state of the chip. When there is a PWM signal into the EN pin, the AW36406 operates in normal state. And the chip would enter shutdown mode if the EN pin is set to low for over 2.5ms, as a built-in shutdown delay circuit in the AW36406. The shutdown current dissipated by the AW36406 is less than 1 μ A.

The AW36406 built in deglitch circuit. The interference between signals inside the portable device is unavoidable, thus deglitch circuit is necessary at the EN pin. The deglitch circuit inside the AW36406 is capable of eliminating the glitch which is narrower than 80ns, preventing the incorrect trigger at the EN pin effectively.

UVLO

The device has under voltage lock-out (UVLO) function to monitor the input voltage. Once the input voltage V_{IN} drops below UVLO falling threshold (around 2.2V), the output current is disabled. Once the input voltage increases above UVLO rising threshold (around 2.4V), the output current resumes its previous setting.

Short Protection

Short protection function will be enabled after LED current starting to ramp. The IC internally compares the voltage difference between V_{IN} and the sink node (LED pin) with a preset threshold. If this difference is below the preset threshold, AW36406 will treat the LED as shorted and disable its Flash/Torch mode current through the LED pin. However, a 2.5mA detecting current will be kept to generate the LED's voltage drop. Because some normal flash LEDs may have larger than desired leakage current (up to hundreds of micro-amps) even if it's not fully turned on, this 2.5mA sensing current can guarantee that a properly functioning LED will not mistakenly be treated as a shorted LED. If the short circuit is removed during operation, the LED will automatically recover to the programmed current setting.

Timeout

The AW36406 has flash time-out protection function. If FLASH/TORCH pin is pulled to high, the chip will work in flash mode(refer to Figure 11). If the time of a flash event exceeds a certain value(about 1.2s), the LED current will be shut off to prevent LED from overheating. LED current can be restarted only by resetting EN again. While if FLASH/TORCH pin is directly pulled to low, AW36406 will work in torch mode(refer to Figure 12).

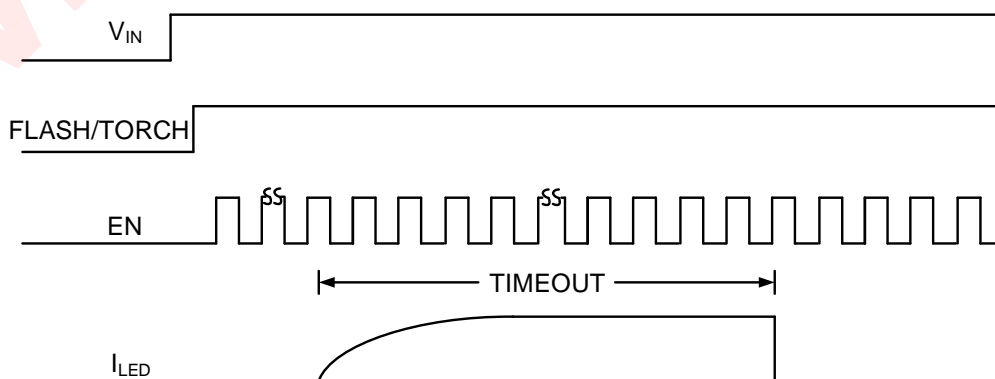

Figure11. Timing Diagram of Flash Mode

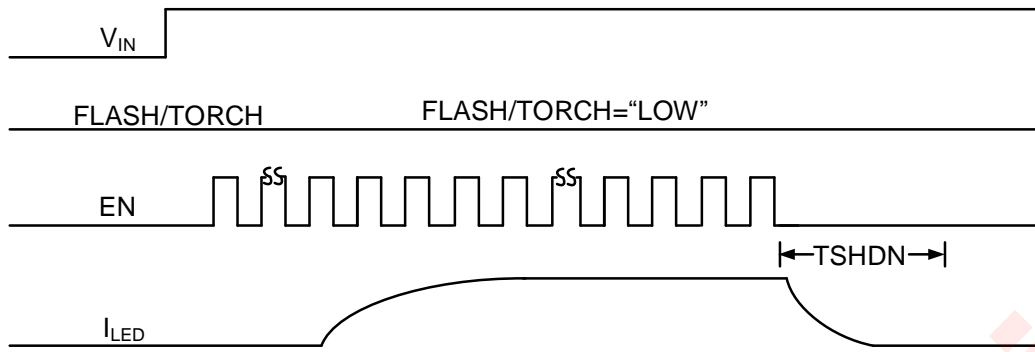

Figure12. Timing Diagram of Torch Mode

Thermal Shutdown

In flash or torch mode, the device has thermal shutdown protection, when the IC temperature goes above thermal shutdown rising threshold (around 155°C), the output current will be disabled. There are 2 conditions should be satisfied at the same time to resume output current: one is the IC temperature drops below thermal shutdown falling threshold (around 135°C); the other is that the chip is reset through EN.

APPLICATION INFORMATION

PWM Dimming

The AW36406 adopts PWM dimming to get an accurate output current. The pulse signal is filtered by an internal low pass filter. The output of filter is connected to an error amplifier as the reference voltage of an internal feedback signal. This can eliminate audio noise which often occurs when LED current is pulsed in replica of the frequency and duty cycle of PWM control. If low time of EN is larger than T_{SHDN} , then the AW36406 will be shut down(refer to Figure 13).

For optimum performance, please use the PWM frequency in the range of 10kHz to 50kHz. This requirement of minimum dimming frequency comes from output ripple. Low frequency will cause high output ripple.

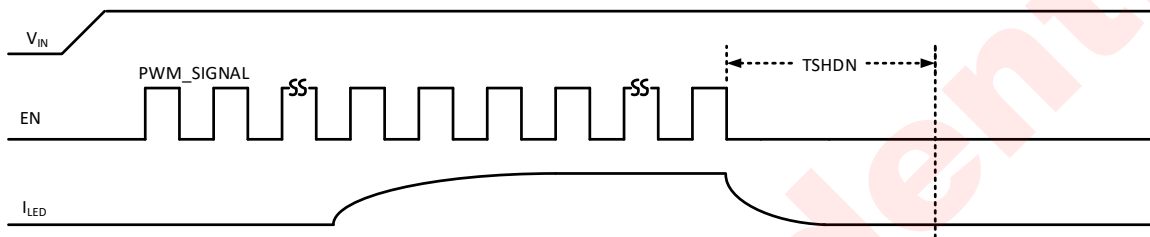

Figure 13. The AW36406 PWM Dimming Timing Diagram

Efficiency

The AW36406 is a low voltage-drop current sink LED driver, its operation efficiency can be approximately calculated as below:

$$\eta = \frac{P_{OUT}}{P_{IN}} = \frac{V_F \times I_{OUT}}{V_{IN} \times I_{IN}} \approx \frac{V_F \times I_{OUT}}{V_{IN} \times I_{OUT}} = \frac{V_F}{V_{IN}}$$

V_F in the formula represents the forward voltage of LED. If V_{IN} is 3.6V, V_F is 3.4V, the chip efficiency is about 94%.

PCB LAYOUT CONSIDERATION

To make fully use of the performance of the AW36406, the guidelines below should be followed:

1. All the peripherals should be placed as close to the device as possible. Place the input capacitor C_{IN} on the top layer (same layer as the AW36406) and close to V_{IN} .
2. Route the power line (shown in Figure 3) as widely and shortly as possible to reduce parasitic impedance.
3. To optimize the heat dissipation performance, the AGND and PGND pins should be connected to the PCB ground plane using as many vias as possible.

TAPE AND REEL INFORMATION

CARRIER TAPE

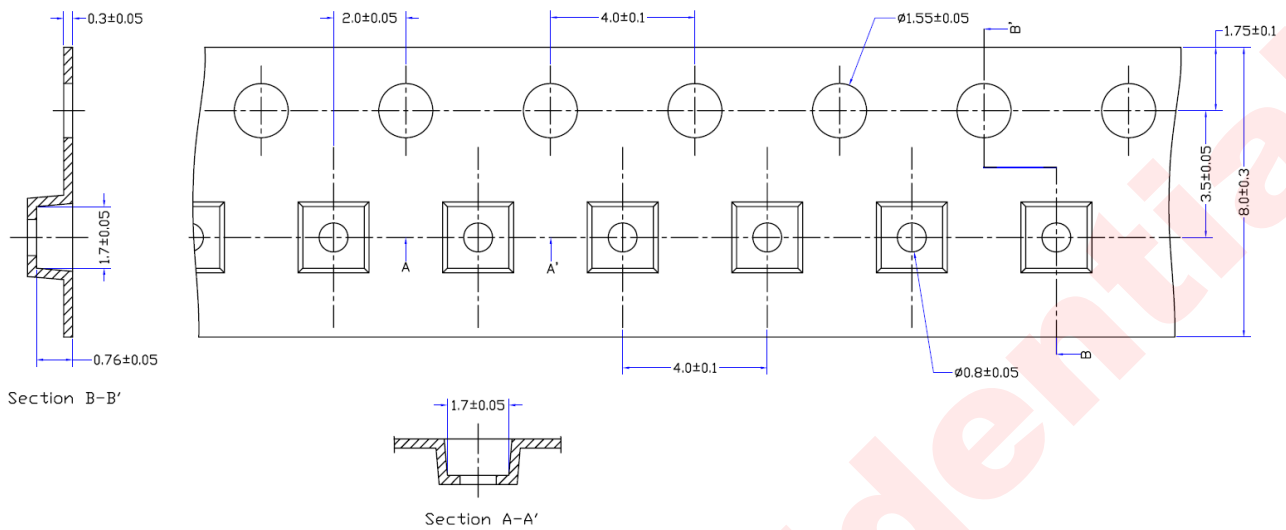

NOTES:

1. 10 pocket hole pitch cumulative tolerance ± 0.2 .
2. Carrier camber is within 1mm in 100mm.
3. MATERIAL: CONDUCTIVE POYSTYRENE.
4. All DIMS in MM.
5. Surface resistance 1×10^{11} (max) OHMS/SQ.

Pin 1

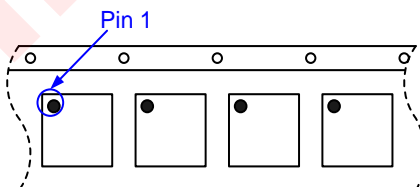

User Direction of Feed

REEL

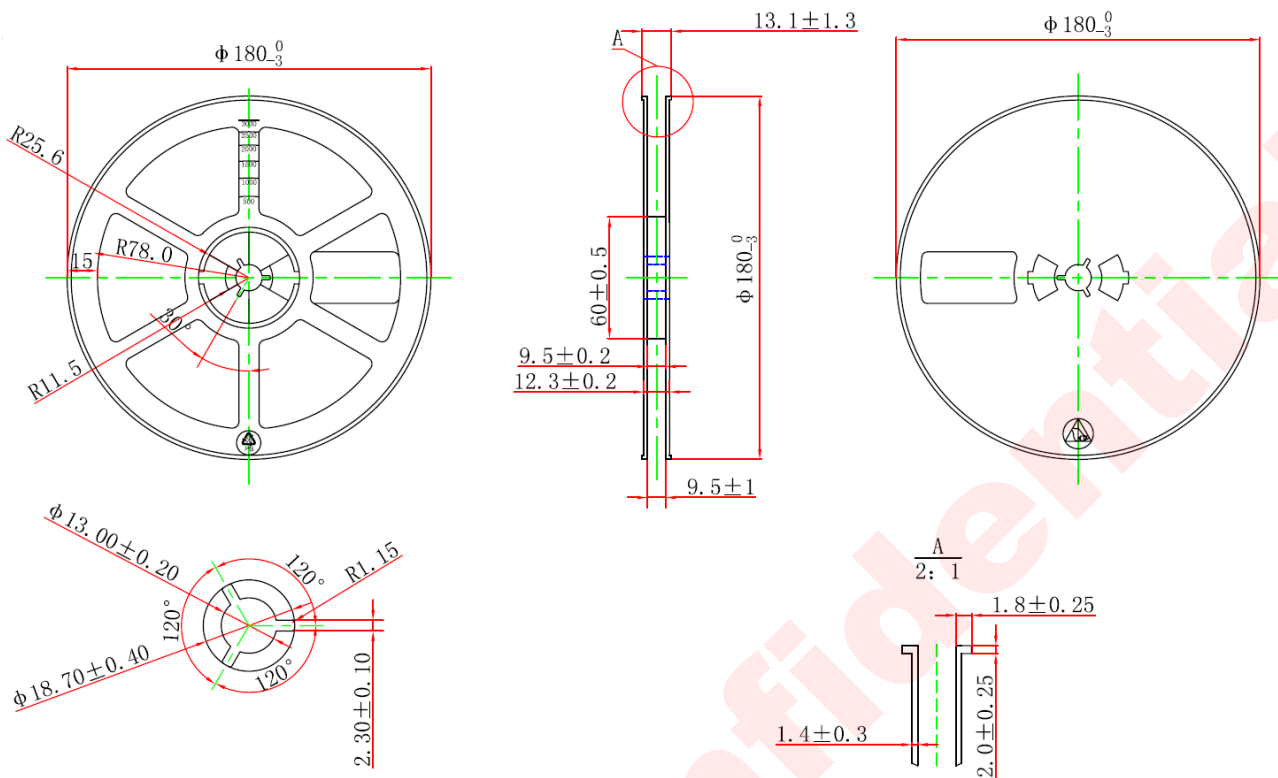

NOTE:

1. All DIMS in mm.
2. General Tolerance ± 0.25 mm.
3. Material: Dissipative.
4. Flange Warpage: 3mm maximum.
5. Surface resistivity: $10E5 \sim 10E11$ OHMS/SQ.

PACKAGE INFORMATION

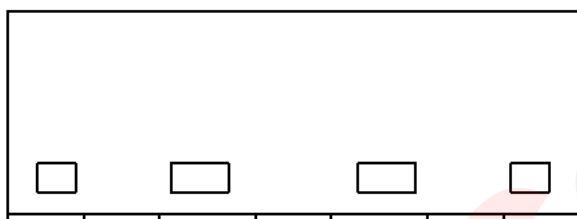
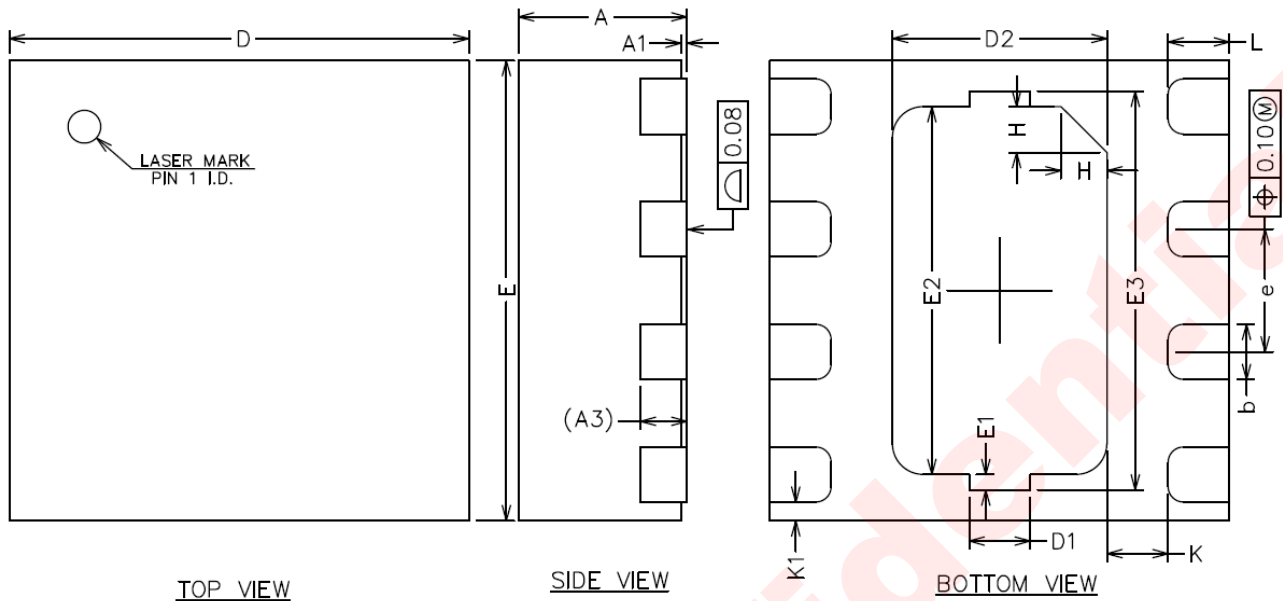

SIDE VIEW

COMMON DIMENSIONS			
UNITS OF MEASURE= MILLIMETER			
SYMBOL	Min.	NOM	Max.
A	0.50	0.55	0.60
A1	0.000	0.02	0.050
A3	0.152REF.		
b	0.150	0.18	0.250
D	1.45	1.50	1.55
D1	0.20REF		
D2	0.65	0.70	0.75
E	1.450	1.50	1.550
E1	0.05REF		
E2	1.15	1.20	1.25
E3	1.25	1.30	1.35
e	0.35	0.40	0.45
H	0.15REF		
K	0.200REF.		
K1	0.03	0.06	0.09
L	0.15	0.20	0.25

NOTE:

1. ALL DIMENSIONS DO NOT INCLUDE MOLD FLASH OR PROTUSION.

LAND PATTERN EXAMPLE

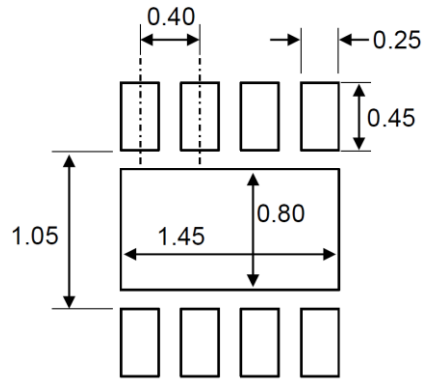
**NOTE:**

Dimensions are in millimeters.

REFLOW

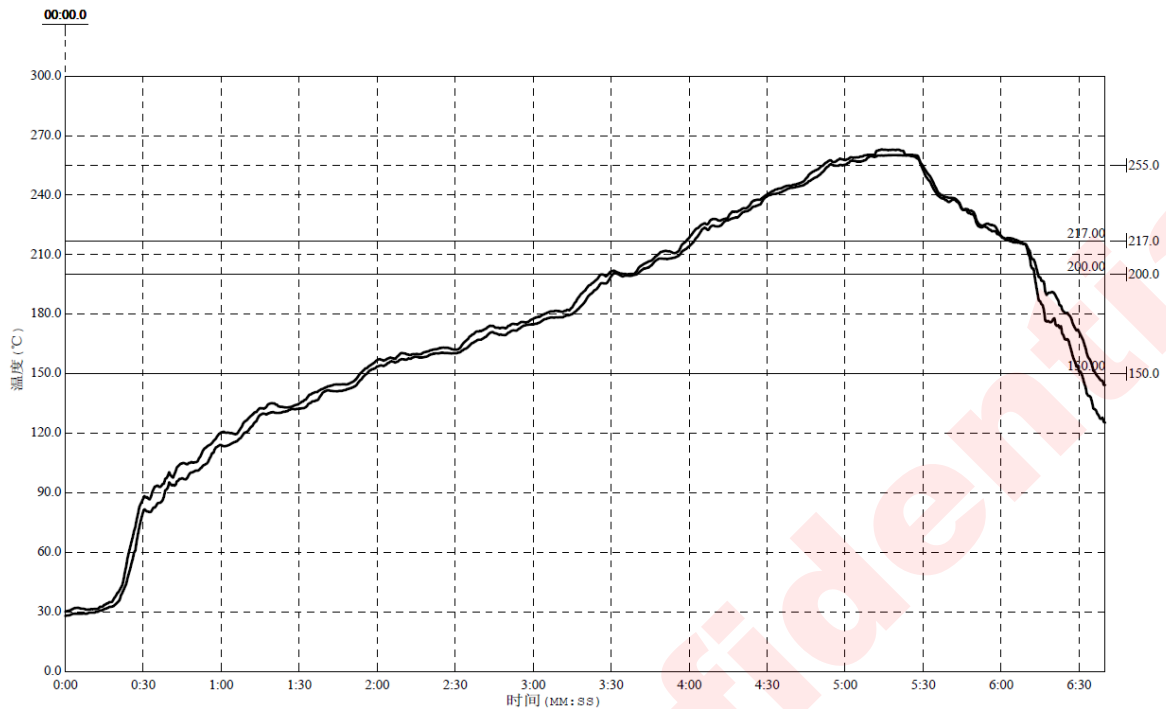

Reflow Note	Spec
Average ramp-up rate (217°C to Peak)	Max. 3°C /sec
Time of Preheat temp.(from 150°C to 200°C)	60-120sec
Time to be maintained above 217°C	60-150sec
Peak Temperature	>260°C
Time within 5°C of actual peak temp	20-40sec.
Ramp-down rate	Max. 6°C /sec
Time from 25°C to peak temp	Max. 8min.

Version information

VERSION	DATE	Change Record
V1.0	2017.10	Datasheet V1.0 Released
V1.1	2018.1	Add User Direction of Feed. (P12)
V1.2	2018.4	1. Add Spec of Torch Current.(P6) 2. Rotate Pin Configuration(Figure 2) by 90 degrees.(P2) 3. Add upper limit of V_{DROP} . (P6)
V1.3	2018.5	1.Modify "Max Junction Temperature T_{JMAX} " from 125°C to 155°C.(P5) 2.Update spec of ILED.(P6)

DISCLAIMER

Information in this document is believed to be accurate and reliable. However, Shanghai AWINIC Technology Co., Ltd (AWINIC Technology) does not give any representations or warranties, expressed or implied, as to the accuracy or completeness of such information and shall have no liability for the consequences of use of such information.

AWINIC Technology reserves the right to make changes to information published in this document, including without limitation specifications and product descriptions, at any time and without notice. Customers shall obtain the latest relevant information before placing orders and shall verify that such information is current and complete. This document supersedes and replaces all information supplied prior to the publication hereof.

AWINIC Technology products are not designed, authorized or warranted to be suitable for use in medical, military, aircraft, space or life support equipment, nor in applications where failure or malfunction of an AWINIC Technology product can reasonably be expected to result in personal injury, death or severe property or environmental damage. AWINIC Technology accepts no liability for inclusion and/or use of AWINIC Technology products in such equipment or applications and therefore such inclusion and/or use is at the customer's own risk.

Applications that are described herein for any of these products are for illustrative purposes only. AWINIC Technology makes no representation or warranty that such applications will be suitable for the specified use without further testing or modification.

All products are sold subject to the general terms and conditions of commercial sale supplied at the time of order acknowledgement.

Nothing in this document may be interpreted or construed as an offer to sell products that is open for acceptance or the grant, conveyance or implication of any license under any copyrights, patents or other industrial or intellectual property rights.

Reproduction of AWINIC information in AWINIC data books or data sheets is permissible only if reproduction is without alteration and is accompanied by all associated warranties, conditions, limitations, and notices. AWINIC is not responsible or liable for such altered documentation. Information of third parties may be subject to additional restrictions.

Resale of AWINIC components or services with statements different from or beyond the parameters stated by AWINIC for that component or service voids all express and any implied warranties for the associated AWINIC component or service and is an unfair and deceptive business practice. AWINIC is not responsible or liable for any such statements.

单击下面可查看定价，库存，交付和生命周期等信息

[>>AWINIC\(艾为\)](#)