

产品规格书

Samples approval sheet

客户名称 (Customer name): _____

产品名称 (Production name): 5050 红/翠绿/蓝全彩

型号 (Model): BQ-5050RGB

编号 (Part number): _____

日期 (Date): _____

佛山市禅城区贝奇光电器材厂			
编制 Prepared by	审核 Checked by	核准 Approved by	市场部 Market Dept

客户确认 Customer Confirmation		
确认 Confirmed by	审核 Checked by	核准 Apporved by

地址 (Add): 佛山市禅城区张槎街道莲塘村莲丰工业开发区北 4-5 号六楼

电话 (Tel): 0757-82026237/82026437

传真 (Fax): 0757-83103903

一、外形图 Outline dimensions:

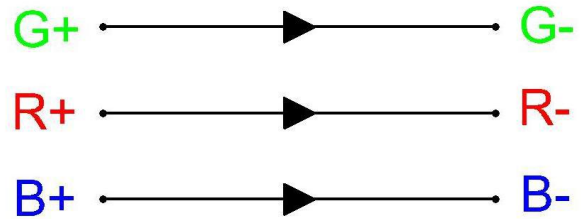
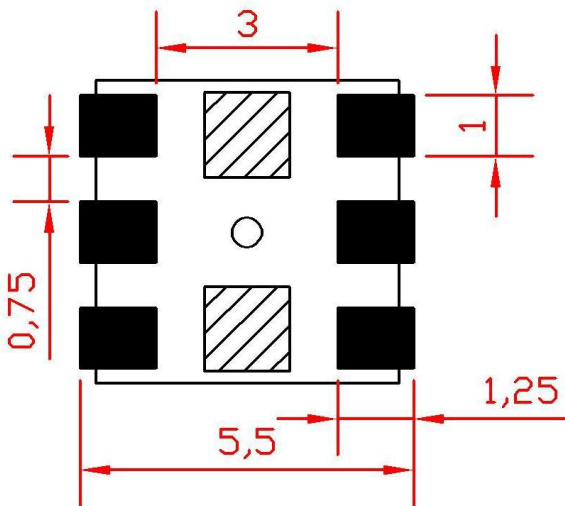
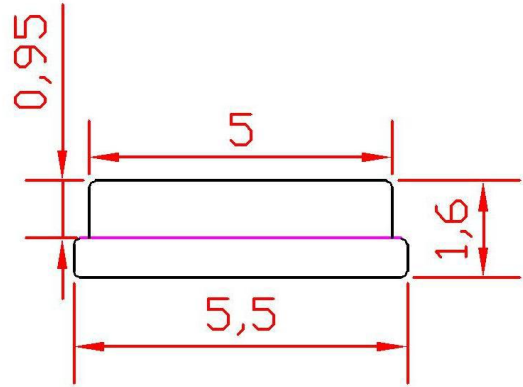
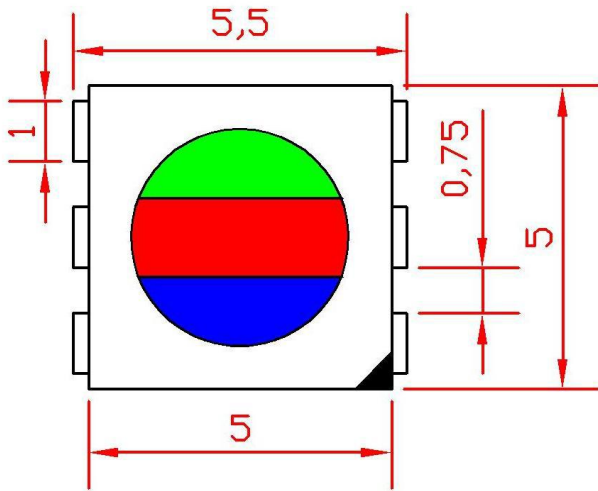

单位 Unit	公差 Tolerance	芯片材质 Die material			发光颜色 Emitting color
		R	G	B	
mm	±0.2mm	AlGaInP	InGaN	InGaN	Full Color

※备注：承认书之编号和型号可用于查询，客户如有需要，请提供相应的编号和型号。

Remark: P/N & Model in samples approval sheet can be used to inquire , please provide corresponding P/N & model if customer need.

二、光电参数 Photo electricity Parameter

(环境温度 Ambient temperature: 25℃ 相对湿度 Humidity: RH 60%)

项目 Item	符号 Symbol	测试条件 Test condition	颜色 Color	最小值 Min	典型值 Type	最大值 Max	单位 Unit
反向电流 Reverse Current	IR	VR=5V	R	/	/	5	μ A
			G	/	/	5	
			B	/	/	5	
正向电压 Forward Voltage	VF	IF=20mA	R	2.0	/	2.3	V
			G	2.9	/	3.2	
			B	2.9	/	3.2	
发光强度 Luminous Intensity	IV		R	800	/	900	mcd
			G	2000	/	3000	
			B	350	/	450	
主波长 Dominant Wavelength	λ d		R	620	/	625	nm
			G	520	/	525	
			B	460	/	470	
半光强角 Viewing Angle	2θ 1/2		R	/	110	/	deg
			G	/	110	/	
			B	/	110	/	

备注: 亮度测试公差±15%, 波长测试公差±1nm, 正向电压测试公差±0.1V

Remark: The tolerance of intensity ±15%, the tolerance of wavelength ±1nm, the tolerance of forwards voltage ±0.1V. Only reference for above when testing.

三、极限参数 Absolute Maximum Rating

(环境温度 Ambient temperature: 25℃ 相对湿度 Humidity: RH 60%)

项目 Item	符号 Symbol	数值 Value	单位 Unit	备注 Remark
正向电流 Forward Current	IF	90	mA	
峰值正向电流* Peak Forward Current*	IFP	100	mA	
功耗 Power Dissipation	PD	150	mW	
工作环境温度 Operation Temperature	Topr	-40 to +85	℃	
贮藏温度 Storage Temperature	Tstg	-40 to +85	℃	
焊接温度 Soldering Temperature	Tsol	260±5℃	℃	Less than 5 Second

*注: 脉冲宽度≤0.1ms, 占空比≤1/10

*Note: pulse Width≤0.1ms, Duty≤1/10

四、可靠性实验项目 Reliability Test Project

实验项目 Test Items	参考标准 Reference	实验条件 Test Conditions	时间 Time	样品数 Quantity	判据 Criterion
冷热冲击 Thermal Shock	MIL-STD-202G	-40°C(15min)←→100°C(15min)	循环200次 200 Cycles	22	0/22
湿热循环 Temperature And Humidity Cyclic	JEITA ED-4701 200 203	(-10-65) °C, (0-90) %RH 24hrs/1 cycle	循环10次 10 Cycles	22	0/22
高温储存 High Temperature storage	JEITA ED-4701 200 201	Ta=100°C	1000h	22	0/22
低温储存 Low Temperature storage	JEITA ED-4701 200 202	Ta=-40°C	1000h	22	0/22
常温寿命实验 Life Test	JESD22-A108D	Ta=25°C IF=20mA	1000h	22	0/22
耐焊接热 Resistance to Soldering Heat	GB/T4937. II.2.2&2.3	Tsol*=(260±5) °C 10secs	2次 2 times	22	0/22

判断标准 Judging Criterion

项目 Item	符号 Symbol	实验条件 Experiment condition	判断标准 Criteria
正向电压 Forward Voltage	VF	IF=IFT	初始值±10% Initial Data ±10%
反向电流 Reverse Current	IR	VR=5V	$I_R \leq 10\mu A$
光强 Luminous Intensity	IV	IF= IFT	平均 IV 衰减≤30%，单个 IV 衰减≤50% Average IV degradation ≤30% ;Single LED IV degradation ≤50%
耐焊接热 Resistance to Soldering Heat			无死灯 No deaded lamp

*注：TSOL-锡液温度；IFT：典型电流

*Note: Tsol-Temperature of tin liquid; IFT: Typical current

典型光电特性曲线 (Typical optical characteristics curves)

- ◆ 发射光谱 (Emission spectrum)
- ◆ 典型辐射分布图 (Typical radiation distribution map)

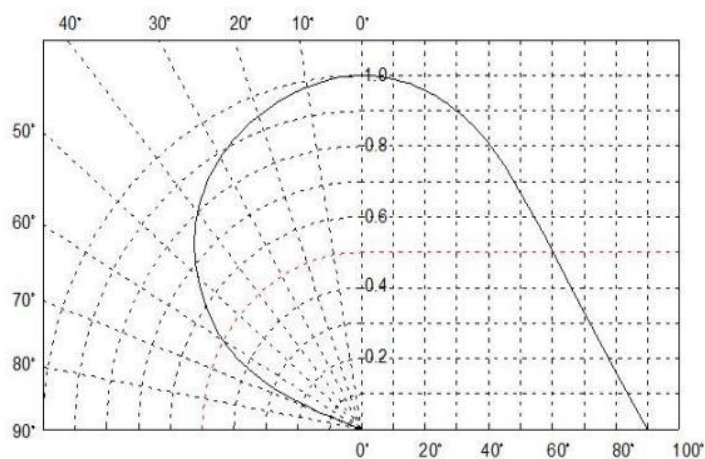
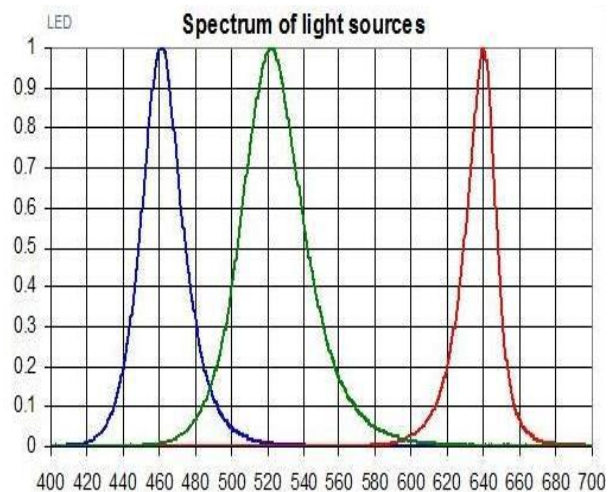

- ◆ 伏安特性 (V-A characteristic)
- ◆ 亮度特性 (Luminance characteristic)

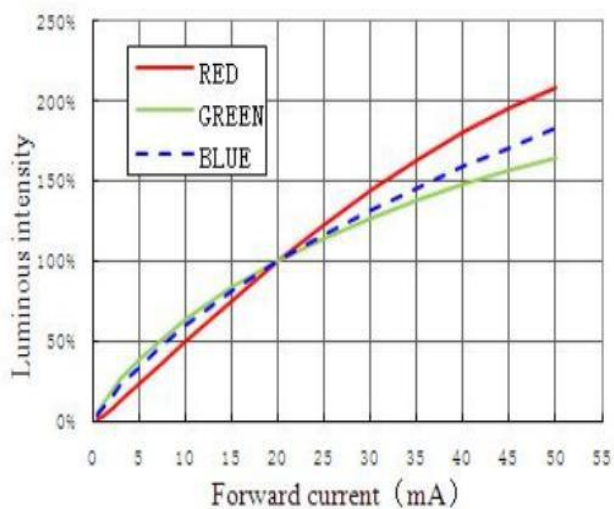
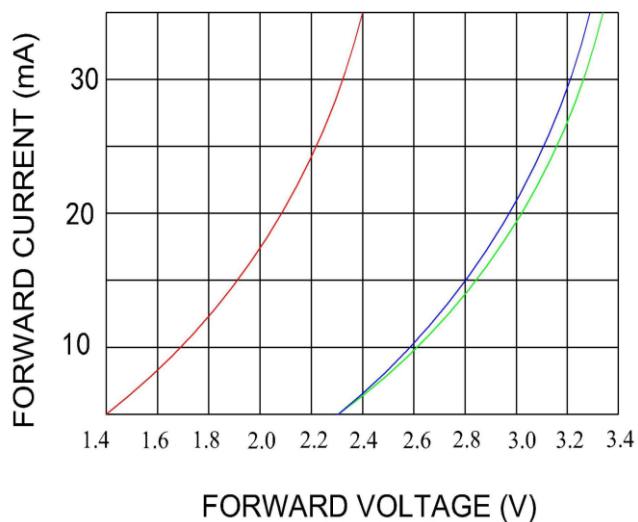

五、注意事项 Note

1. 贮存:

Storage

- 产品在运输和储存中要注意防潮，需使用密封防潮防静电袋包装，并内附干燥剂、湿度卡，湿度卡可显示防静电铝箔袋内的湿度。

In order to prevent moisture absorption into the SMD LEDs during the transportation and storage, the LEDs are packed in moisture-proof barrier bag. Desiccants and a humidity indicator are packed together with the SMD LEDs as secondary protection. The humidity-indicator card indicates the humidity within the SMD packing.

- 开封前，产品须存放在温度不高于 30℃，湿度不高于 60%RH 的环境中。

Before opening the package, the product should be kept at 30℃ or less and 60% RH or less.

- 开封后，产品须存放在温度不高于 30℃，湿度不高于 60%RH 的环境中，最长存放时间 168 小时，未用完的余料需重新存放在密封防潮防静电袋内。

After opening the package :The Led's floor life is 168Hrs under 30℃ or less and 60%RH or less, if unused LEDs remain,it should be stored in moisture proof packages.

- 对于尚未焊接的 LED，如果吸湿剂或包装失效，或者产品没有符合以上有效存储条件，烘焙可以起到一定的性能恢复效果。烘焙条件：(60±5)℃，持续 24 小时。

If the moisture absorbent material has fade away or the LEDs have exceeded the storage time, baking treatment should be performed using the following condition.

Baking treatment:(60±5) °C for 24hours.

2. 静电:

Static Electricity

静电和电涌会导致产品特性发生改变，例如正向电压降低等，如果情况严重甚至会损毁产品。所以在使用时必须采取有效的防静电措施。

所有相关的设备和机器都应该正确接地，同时必须采取其他防止静电和电涌的措施。

使用防静电手环，防静电垫子，防静电工作服、工作鞋、手套，防静电容器，都是有效的防止静电和电涌的措施。

Static electricity or surge voltage damages the LEDs. Damaged LEDs will show some unusual characteristic such as the forward voltage becomes lower, or the LEDs do not light at the low current. even not light.

All devices, equipment and machinery must be properly grounded. At the same time, it is recommended that wrist bands or anti-electrostatic gloves, anti-electrostatic containers be used when dealing with the LEDs.

3. 设计建议:

Design Consideration

设计电路时，通过 LED 的电流不能超过规定的最大值，同时，还需使用保护电阻，否则，微小的电压变化将会引起较大的电流变化，可能导致产品损毁。

建议使用以下 (A) 电路，该电路能够很好的调节通过每个 LED 的电流；不推荐使用 (B) 电路，该电路在持续的电压驱动下，LED 的正向电压 (V_F) 发生变化，电流会随之而发生变化，可能使某些 LED 承受高于规定的电流值。

In designing a circuit, the current through each LED must not exceed the absolute maximum rating specified for each LED. In the meanwhile, Customer must apply resistors for protection, otherwise slight voltage shift will cause big current change, burn out will happen.

It is recommended to use Circuit A which regulates the current flowing through each LED rather than Circuit B. When driving LEDs with a constant voltage in Circuit B, the current through the LEDs may vary due to the variation in Forward Voltage (V_f) of the LEDs. In the worst case, some LED may be subjected to stresses in excess of the Absolute Maximum Rating.

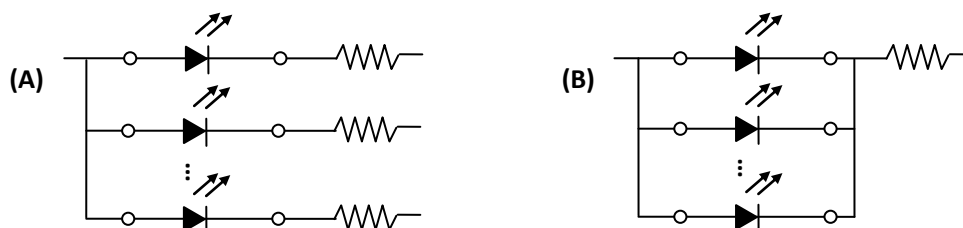

LED 的特性容易因为自身的发热和环境的温度的改变而发生改变。温度的升高会降低 LED 的发光效率、影响发光颜色等，所以在设计时应充分考虑散热的问题。

Thermal Design is paramount importance because heat generation may result in the Characteristics decline, such as brightness decreased, Color changed and so on. Please consider the heat generation of the LEDs when making the system design.

1. 其他事项:

Others

直接用手拿取产品不但会污染封装树脂表面，也可能由于静电等因素导致产品性能的改变。过度的压力也可能直接影响封装内部的管芯和金线，因此请勿对产品施加过度压力，特别当产品处于高温状态下，例如在回流焊接过程中。

When handling the product, touching the encapsulant with bare hands will not only contaminate its surface, but also affect on its optical characteristic. Excessive force to the encapsulant might result in catastrophic failure of the LEDs due to die breakage or wire deformation. For this reason, please do not put excessive stress on LEDs, especially when the LEDs are heated such as during Reflow Soldering.

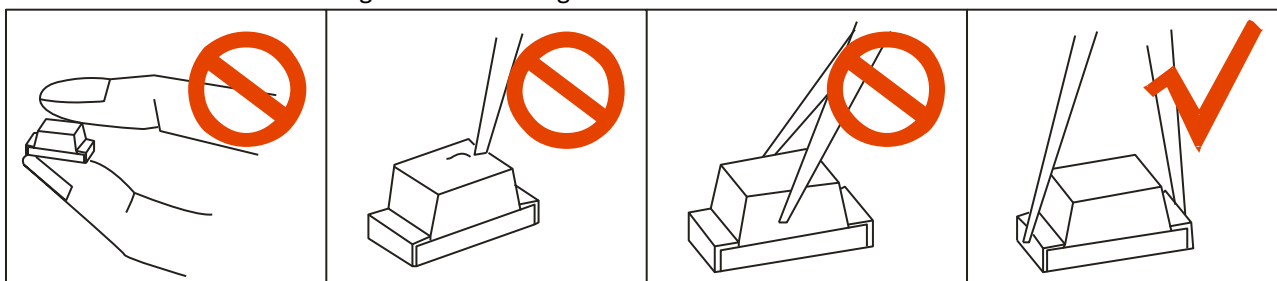

LED 的环氧树脂封装部分相当脆弱，请勿用坚硬、尖锐的物体刮、擦封装树脂部分。在用镊子夹取的时候也应当小心注意。

The epoxy resin of encapsulant is fragile, so please avoid scratch or friction over the epoxy resin surface. While handling the product with tweezers, do not hold by the epoxy resin, be careful

2. 眼睛保护忠告:

Safety Advice for Human Eyes

LED 发光时, 请勿直视发光光源, 特别是对于一些光强较高的 LED, 强光可能伤害你的眼睛。

Viewing direct to the light emitting center of the LEDs, especially those of great Luminous Intensity will cause great hazard to human eyes. Please be careful.

六、焊接指导 **Soldering instruction**

1. 使用烙铁人手焊接

Hand Soldering

推荐使用功率低于 20W 的烙铁, 焊接时烙铁的温度必须保持在 360°C 以下, 且每个电极只能进行一次焊接, 每次焊接的持续时间不得超过 3 秒。

人手焊接过程中的不慎操作易引起 LED 产品的损坏, 应当小心谨慎。

If manual soldering is necessary, the use of a soldering iron of less than 20W is recommended, and the temperature of the iron must be kept at below 360°C, with soldering time within 3 seconds.

No mechanical stress should be exerted on the resin portion of the SMD LED during soldering.

2. 回流焊接: 推荐使用以下无铅回流焊接温度图进行。

Reflow Soldering: Use the conditions shown in the under Figure of Pb-Free Reflow Soldering.

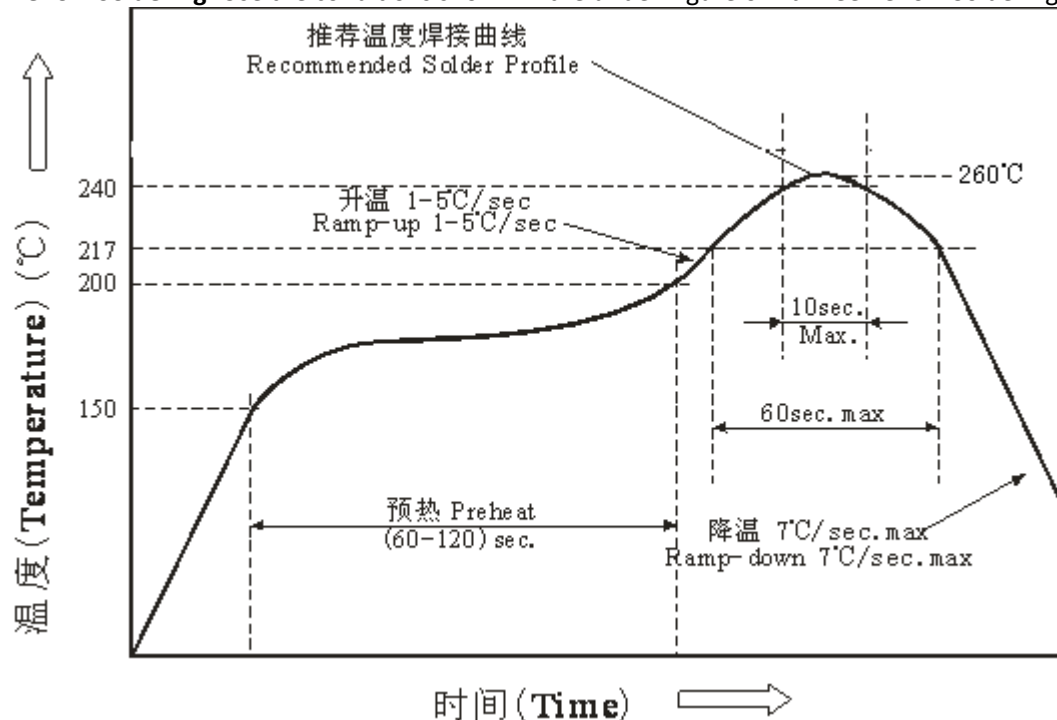

- 回流焊接最多只能进行两次。

Reflow soldering should not be done more than two times.

- 在回流焊接升温过程中, 请不要对 LED 施加任何压力。

No stress should be exerted on the package during Soldering.

- 在焊接完成后, 待产品温度下降到室温之后, 再进行其他处理。

After soldering, do not deal with the product before its temperature cooling down to room temperature.

3. 清洗:

Cleaning

在焊接后推荐使用酒精进行清洗，在温度不高于 30°C 的条件下持续 3 分钟，不高于 50°C 的条件下持续 30 秒。使用其他类似溶剂清洗前，请先确认使用的溶剂不会对 LED 的封装和环氧树脂部分造成损伤。

超声波清洗也是有效的方法，一般最大功率不应超过 300W，否则可能对 LED 造成损伤。请根据具体的情况预先测试清洗条件是否会对 LED 造成损伤。

It is recommended that alcohol be used as a solvent for cleaning after soldering. Cleaning is to go under 30°C for 3 minutes or 50°C for 30 seconds. When using other solvents, it should be confirmed beforehand whether the solvents will dissolve the package and the resin or not.

Ultrasonic cleaning is also an effective way for cleaning. But the influence of Ultrasonic cleaning on LED depends on factors such as ultrasonic power. Generally, the ultrasonic power should not be higher than 300W. Before cleaning, a pre-test should be done to confirm whether any damage to LEDs will occur.

* **注意:** 此一般指导原则并不适用于所有 PCB 设计和焊接设备的配置。具体工艺受到诸多因素的影响，请根据特定的 PCB 设计和焊接设备来确定焊接方案。

* **Note:** This general guideline may not apply to all PCB designs and configurations of all soldering equipment. The technique in practice is influenced by many factors it should be specialized base on the PCB designs and configurations of the soldering equipment.

卷盘包装规格 (Reel packaging specification)

◆ 卷带输送方 (Feeding Direction)

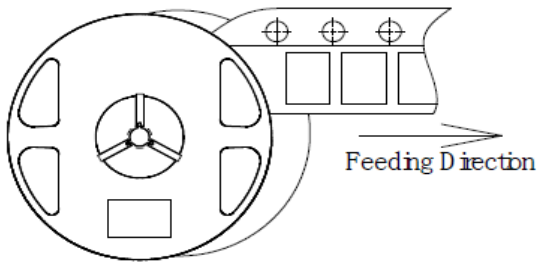

◆ 卷盘尺寸 (Dimensions of Reel)

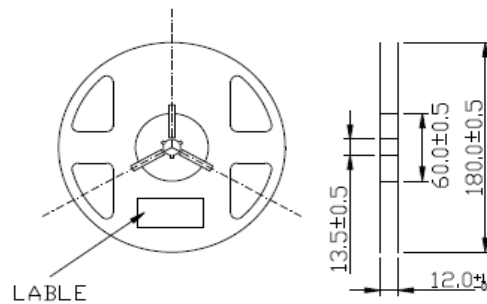

◆ 卷带尺寸 (Dimensions of Tape)

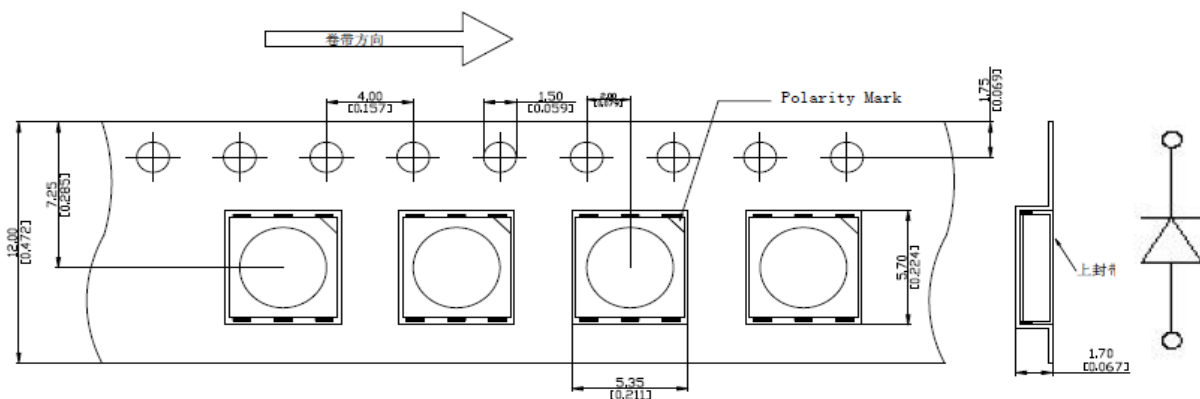

单击下面可查看定价，库存，交付和生命周期等信息

[>>BeiQi](#)