

FEATURES

- Programmable Charge Current Up to 800mA
- No MOSFET, Sense Resistor or Blocking Diode Required
- Preset 4.2V Charge Voltage with $\pm 1\%$ Accuracy
- Charge Current Monitor Output for Gas Gauging
- Thermal Regulation Maximizes Charge Rate Without Risk of Overheating
- Charges Single Cell Li-Ion Batteries Directly from USB Port
- Over-Voltage Protect
- Automatic Recharge
- Charge Status Output Pin
- C/10 Charge Termination
- 25 μ A Supply Current in Shutdown
- 2.9V Trickle Charge Threshold
- Soft-Start Limits Inrush Current
- Available in 5-Lead SOT-23 Package

APPLICATIONS

- Cellular and Smart Phones
- Charging Docks and Cradles
- Bluetooth Applications
- PDAs
- MP3/MP4/MP5 Players

DESCRIPTION

The BL4054/BL4054B is a complete constant current / constant voltage linear charger for single cell Lithium-Ion batteries. No external sense

resistor is needed, and no blocking diode is required due to the internal MOSFET architecture. Thermal feedback regulates the charge current to limit the die temperature during high power operation or high ambient temperature. The charge voltage is fixed at 4.2V, and the charge current can be programmed externally with a single resistor. The BL4054/BL4054B automatically terminates the charge cycle when the charge current drops to 1/10 the programmed value after the final float voltage is reached.

When the input supply (wall adapter or USB supply) is removed, the BL4054/BL4054B automatically enters a low current state, dropping the battery drain current to less than 2 μ A. The BL4054/BL4054B can be put into shutdown mode, reducing the supply current to 25 μ A. Other features include charge current monitor, under-voltage lockout, automatic recharge and a status pin to indicate charge termination and the presence of an input voltage.

The only difference between BL4054 and BL4054B is that at power on, BL4054 will check the battery voltage first, it will not start charging unless the battery voltage is below the auto-recharge threshold. BL4054B does not perform this check. So BL4054B can guarantee the high battery capacity at all time, while BL4054 can prevent the battery from being repeatedly charged in some specific applications.

ORDERING INFORMATION

BL4054/BL4054B – XX X X XXX

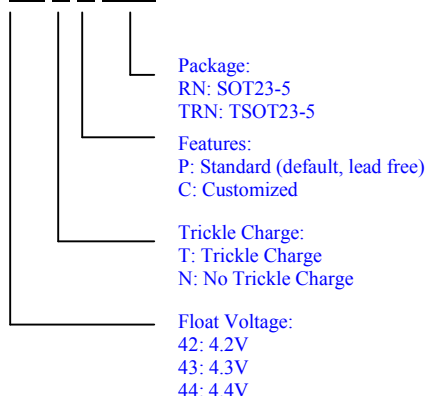

TYPICAL APPLICATION

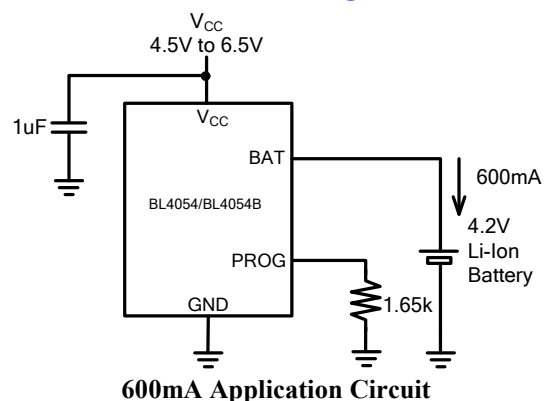

Absolute Maximum Rating (Note 1)

Input Supply Voltage (V_{CC})	-0.3V to +10V	PROG Pin Current	800 μ A
PROG Voltage	-0.3V to + V_{CC}	Maximum Junction Temperature	125°C
BAT Voltage	-0.3V to 7V	Operating Temperature Range <small>(Note2)</small>	-40°C to 85°C
CHRGb	-0.3V to 10V	Storage Temperature Range	-65°C to 125°C
BAT Short-Circuit Duration	Continuous	Lead Temperature (Soldering, 10s)	300°C
BAT Pin Current	800mA		

Package Information

Part Number	Top Mark	Temp Range
BL4054-4.2	B A Y W <small>(Note3)</small>	-40°C to +85°C
BL4054-4.3	B B Y W	
BL4054-4.4	B C Y W	
BL4054B-4.2	<u>B</u> A Y W	
BL4054B-4.3	<u>B</u> B Y W	
BL4054B-4.4	<u>B</u> C Y W	

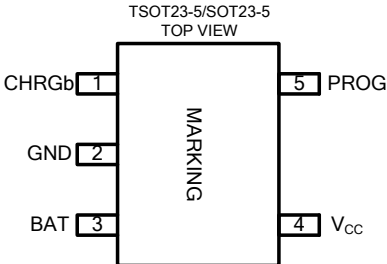

Thermal Resistance (Note 4)

Package	Θ_{JA}	Θ_{JC}
TSOT23-5	220°C/W	110°C/W
SOT23-5	250°C/W	130°C/W

Note 1: Absolute Maximum Ratings are those values beyond which the life of a device may be impaired.

Note 2: The BL4054/BL4054B is guaranteed to meet performance specifications from 0°C to 70°C. Specifications over the -40°C to 85°C operating temperature range are assured by design, characterization and correlation with statistical process controls.

Note 3: X: Product Code (BL4054:B, BL4054B:B) V: Voltage Code (4.2V:A, 4.3V:B, 4.4V:C) Y: Year of Manufacturing (A-J) W: Week of Manufacturing (W:A-Z, a-z). Contact Belling marketing for more information in detail.

Note 4: Thermal Resistance is specified with approximately 1 square of 1 oz copper.

Pin Description

PIN	NAME	FUNCTION
1	CHRGb	Open-Drain Charge Status Output. When the battery is charging, the CHRGb pin is pulled low by an internal N-channel MOSFET. When the charge cycle is completed, a weak pull-down of approximately 12 μ A is connected to the CHRGb pin, indicating an "AC present" condition. When the BL4054/BL4054B detects an under-voltage lockout condition, CHRGb is forced high impedance.
2	GND	Ground
3	BAT	Charge Current Output. Provides charge current to the battery and regulates the final float voltage to 4.2V. An internal precision resistor divider from this pin sets the float voltage which is disconnected in shutdown mode.
4	V _{CC}	Positive Input Supply Voltage. Provides power to the charger. V _{CC} can range from 4.25V to 6.5V and should be bypassed with at least a 1 μ F capacitor. When V _{CC} drops to within 30mV of the BAT pin voltage, the BL4054/BL4054B enters shutdown mode, dropping I _{BAT} to less than 2 μ A.
5	PROG	Charge Current Program, Charge Current Monitor and Shutdown Pin. The charge current is Programmed by connecting a 1% resistor, R _{PROG} , from this pin to ground. When charging in constant-current mode, this pin serves to 1V. In all modes, the voltage on this pin can be used to measure the charge current using the following formula: $I_{BAT} = (V_{PROG} / R_{PROG}) \cdot 1000$ The PROG pin can also be used to shut down the charger. Disconnecting the Program resistor from ground allows a 3 μ A current to pull the PROG pin high. When it reaches the 1.21V shutdown threshold voltage, the charger enters shutdown mode, charging stops and the input supply current drops to 25 μ A. This pin is also clamped to approximately 2.4V. Driving this pin to voltages beyond the clamp voltage will draw currents as high as 1.5mA. Reconnecting R _{PROG} to ground will return the charger to normal operation.

Block Diagram

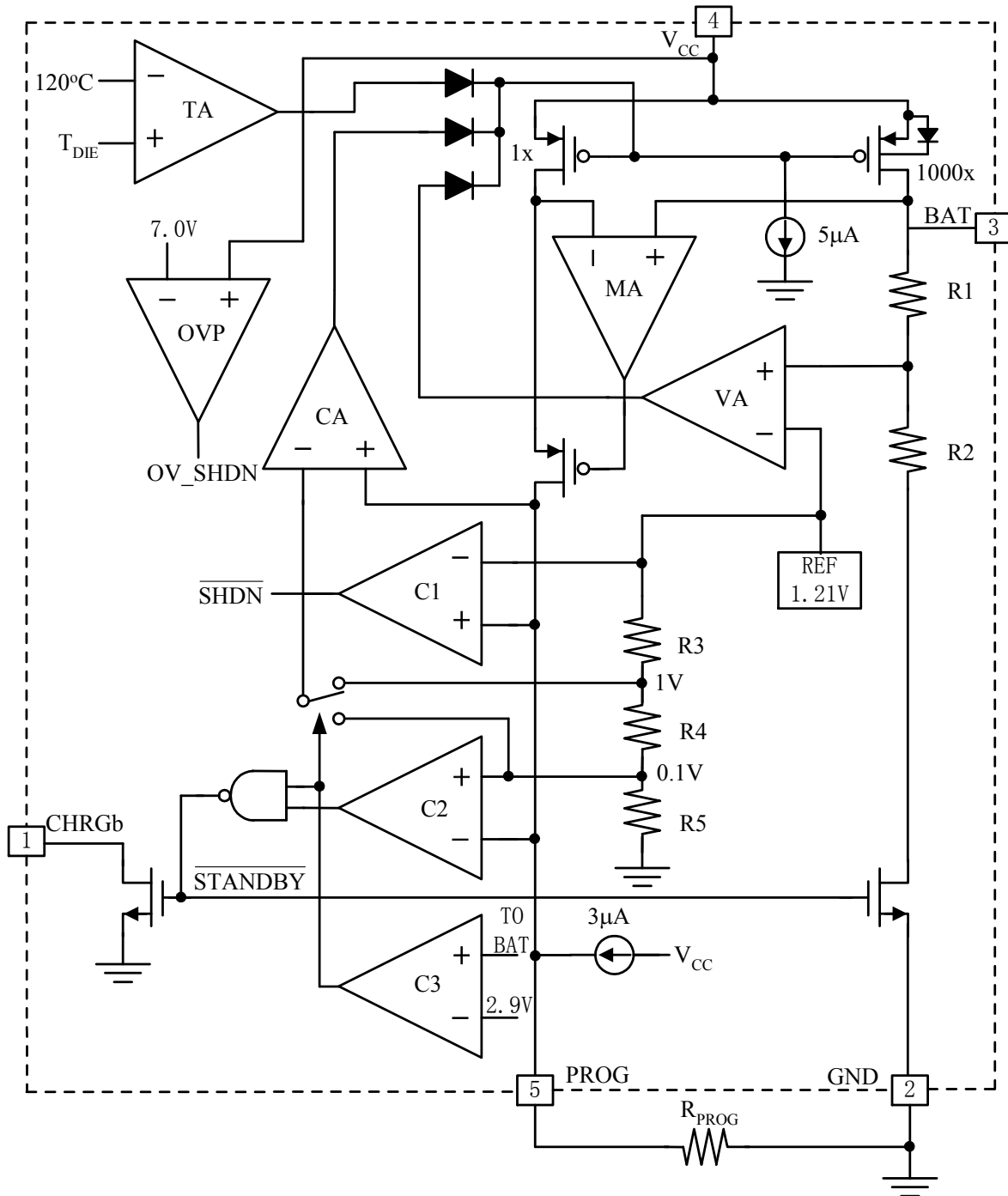

Electrical Characteristics ^(Note 5) ($V_{CC} = 5V$, $T_A = 25^\circ C$, unless otherwise noted.)

Symbol	Parameter	Conditions	Min	Typ	Max
$I_{SPLYCHRG}$	Charge Mode Supply Current ^(Note6)	$R_{PROG} = 2k\Omega$ $R_{PROG} = 10k\Omega$		300 μA	2000 μA 2000 μA
$I_{BATCHRG}$	Charge Mode Battery Current	$R_{PROG} = 2k\Omega$ $R_{PROG} = 10k\Omega$	465mA 93mA	500mA 100mA	535mA 107mA
$V_{PROGCHRG}$	PROG Pin Voltage	$R_{PROG} = 2k\Omega$ $R_{PROG} = 10k\Omega$	0.93V 0.93V	1V 1V	1.07V 1.07V
$I_{SPLYSTBY}$	Standby Mode Supply Current			100 μA	500 μA
$I_{BATSTBY}$	Standby Mode Battery Current		0	-2.5 μA	-6 μA
$I_{SPLYMSD}$	Manual Shutdown Mode Supply Current				90 μA
I_{BATMSD}	Manual Shutdown Mode Battery Current		-2 μA	0	2 μA
$V_{PROGCLMP}$	PROG Pin Clamp Voltage		2V		3V
$I_{SPLYASD}$	Automatic Shutdown Mode Supply Current			25 μA	50 μA
I_{BATASD}	Automatic Shutdown Mode Battery Current		-2 μA	0	2 μA
$I_{SPLYUVLO}$	UVLO Mode Supply Current			25 μA	50 μA
$I_{BATUVLO}$	UVLO Mode Battery Current		-2 μA		2 μA
$I_{BATSLEEP}$	Sleep Mode Battery Current		-1 μA		1 μA
V_{FLOAT}	Float Voltage		4.158V	4.2V	4.242V
I_{TRIKL}	Trickle Charge Current	$R_{PROG} = 2k\Omega$ $R_{PROG} = 10k\Omega$	20mA 5mA	50mA 10mA	70mA 15mA
V_{TRIKL}	Trickle Charge Threshold		2.8V	2.9V	3V
$V_{TRIKL, HYS}$	Trickle Charge Hysteresis		60mV	100mV	150mV
V_{UVLO}	UVLO Threshold		3.7V	3.9V	4.1V
$V_{UVLO, HYS}$	UVLO Hysteresis		150mV	200mV	300mV
V_{OVP}	Input Over-Voltage Protect Threshold		6.8V	7V	7.2V
$V_{OVP, HYS}$	Input Over-Voltage Protect Hysteresis			200mV	

$V_{MSD, RISE}$	Manual Shutdown Threshold, PROG rising		1.15V	1.21V	1.3V
$V_{MSD, FALL}$	Manual Shutdown Threshold, PROG falling		0.95V	1.0V	1.05V
$V_{ASD, RISE}$	Automatic Shutdown Threshold, BAT rising		5mV	30mV	50mV
$V_{ASD, FALL}$	Automatic Shutdown Threshold, BAT falling		70mV	100mV	140mV
I_{TERM}	C/10 Termination Current Threshold		85mV	100mV	115mV
V_{RECHRG}	Auto Recharge Battery Voltage		4V	4.05V	4.1V
I_{CHRGb}	CHRGb Pin Weak Pull-down Current		8 μ A	12 μ A	35 μ A
V_{CHRGb}	CHRGb Pin Output Low Voltage			0.35V	0.6V
T_{LIM}	Junction Temperature In Constant Temperature Mode			120°C	
R_{ON}	Power FET ON Resistance			600m Ω	
T_{SS}	Soft-Start Time	$R_{PROG} = 2k\Omega$		50 μ s	
T_{RECHRG}	Recharge Comparator Filter Time		0.75ms	2ms	4.5ms
T_{TERM}	Termination Comparator Filter Time		0.4ms	1ms	2.5ms
I_{PROG}	PROG Pin Pull-up Current			3 μ A	

Note 5: 100% production test at +25°C. Specifications over the temperature range are guaranteed by design and characterization.

Note 6: Supply current includes PROG pin current (approximately 100 μ A) but does not include any current delivered to the battery through the BAT pin (approximately 100mA).

Typical Performance Characteristics

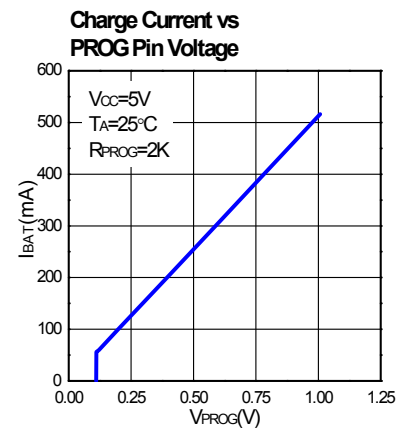
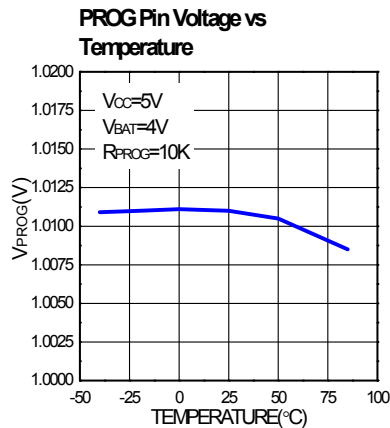
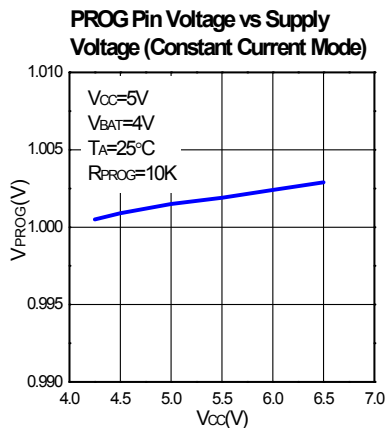

Typical Performance Characteristics

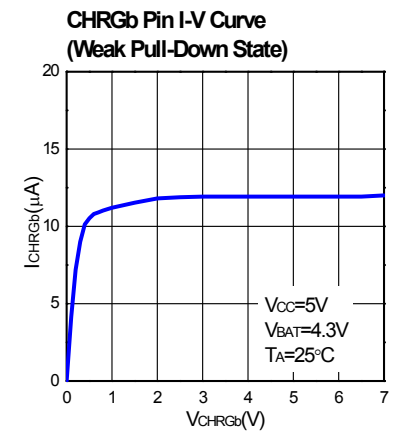
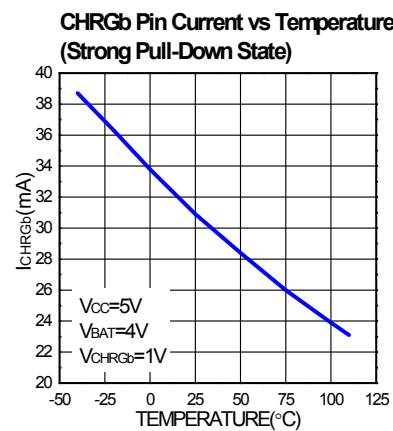
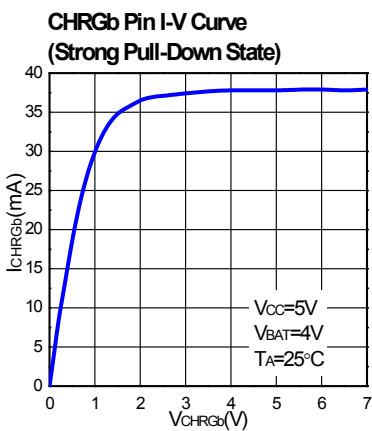
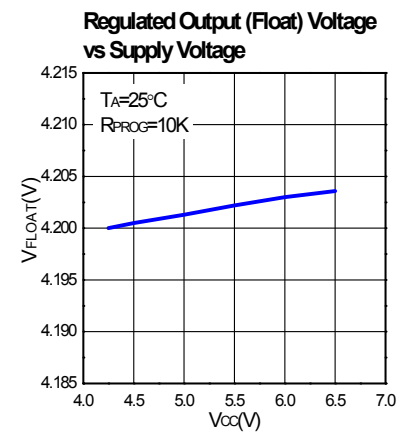
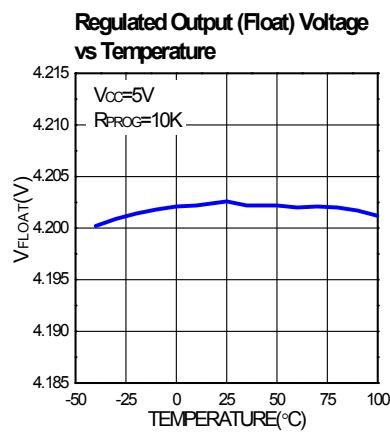
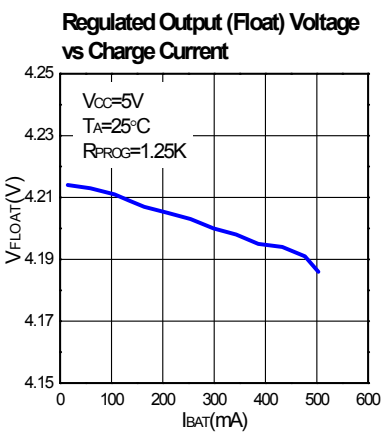
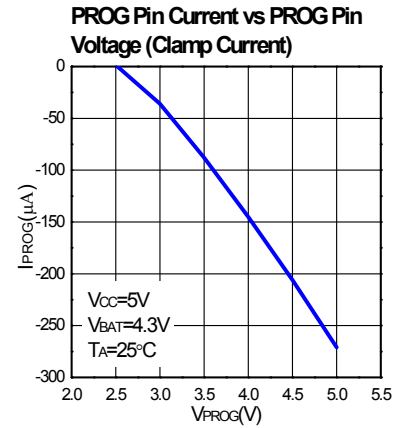
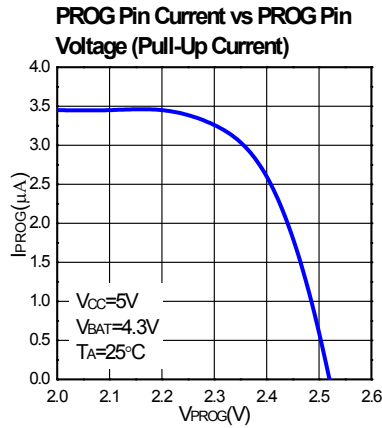
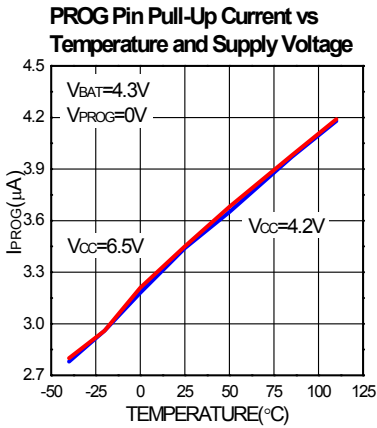

Typical Performance Characteristics

CHRGb Pin Current vs Temperature (Weak Pull-Down State)

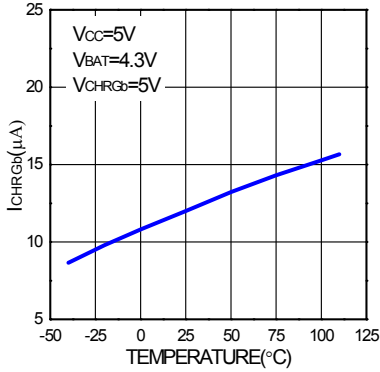

Trickle Charge Current vs Temperature

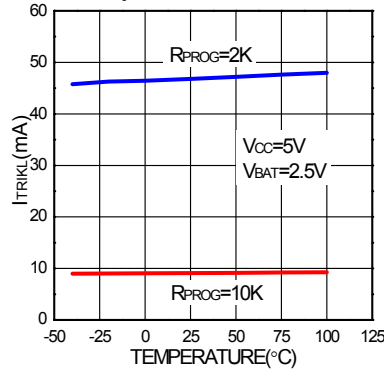

Trickle Charge Current vs Supply Voltage

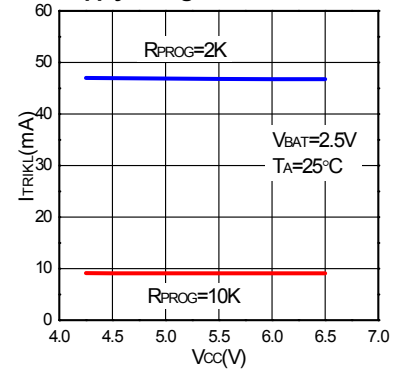

Trickle Charge Threshold vs Temperature

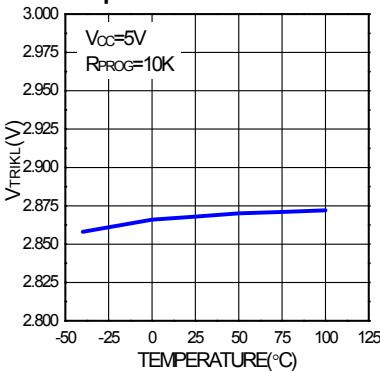

Charge Current vs Battery Voltage

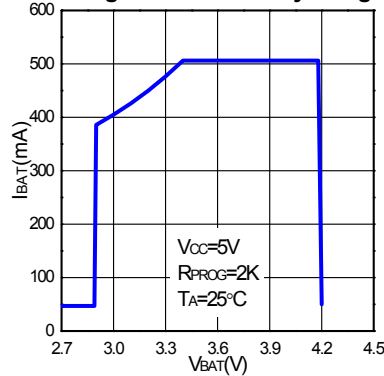

Charge Current vs Supply Voltage

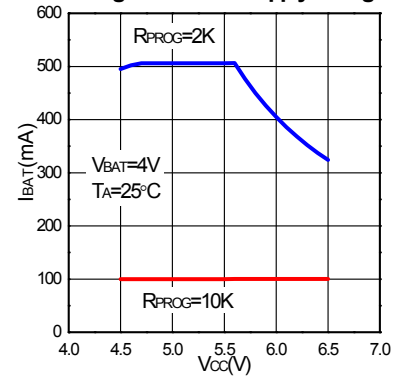

Charge Current vs Ambient Temperature

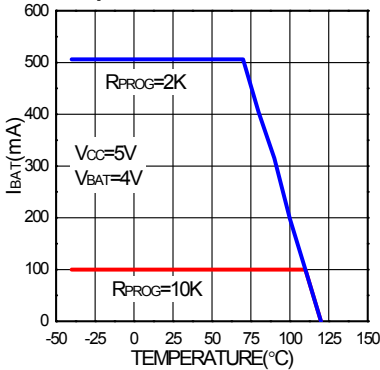

Recharge Voltage Threshold vs Temperature

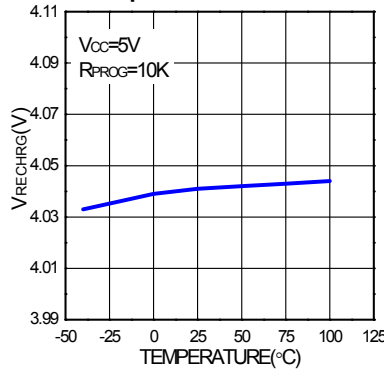

Power FET "ON" Resistance vs Temperature

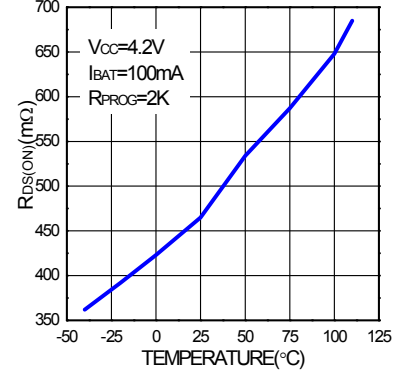

Operation

The BL4054/BL4054B is a single cell Lithium-Ion battery charger using a constant current / constant voltage algorithm. It can deliver up to 800mA of charge current (using a good thermal PCB layout) with a final float voltage accuracy of 1%. The BL4054/BL4054B includes an internal P-channel power MOSFET and thermal regulation circuitry. No blocking diode or external current sense resistor is required; thus, the basic charger circuit requires only two external components. Furthermore, the BL4054/BL4054B is capable of operating from a USB power source.

Normal Charge Cycle

A charge cycle begins when the voltage at the V_{CC} pin rises above the UVLO threshold level and a 1% program resistor is connected from the PROG pin to ground or when a battery is connected to the charger output. If the BAT pin is less than 2.9V, the charger enters trickle charge mode. In this mode, the BL4054/BL4054B supplies approximately 1/10 the programmed charge current to bring the battery voltage up to a safe level for full current charging.

When the BAT pin voltage rises above 2.9V, the charger enters constant-current mode, where the programmed charge current is supplied to the battery. If the battery voltage is above 2.9V at power-on, BL4054B enters the constant-current mode immediately, while BL4054 will perform one more check. If the battery voltage is below the auto-recharge threshold, BL4054 enters the constant current mode, otherwise it goes to standby mode. This is the only difference between the BL4054 and BL4054B. Refer to Figure 1a and 1b for more details.

When the BAT pin approaches the final float voltage (4.2V), the BL4054/BL4054B enters constant-voltage mode and the charge current begins to decrease. When the charge current drops to 1/10 of the programmed value, the charge cycle ends.

Programming Charge Current

The charge current is programmed using a single resistor from the PROG pin to ground. The battery charge current is 1000 times the current out of the PROG pin. The program resistor and the charge current are calculated using the following equations:

$$R_{\text{PROG}} = \frac{1000V}{I_{\text{CHG}}} \quad I_{\text{CHG}} = \frac{1000V}{R_{\text{PROG}}}$$

In order to ensure the stability of operation, I_{CHG} should be greater than 40mA.

The charge current out of the BAT pin can be determined at any time by monitoring the PROG pin voltage using the following equation:

$$I_{\text{BAT}} = \frac{V_{\text{PROG}}}{R_{\text{PROG}}} \cdot 1000$$

Charge Termination

A charge cycle is terminated when the charge current falls to 1/10 the programmed value after the final float voltage is reached. This condition is detected by using an internal, filtered comparator to monitor the PROG pin. When the PROG pin voltage falls below 100mV for longer than T_{TERM} (typically 1ms), charging is terminated. The charge current is latched off and the BL4054/BL4054B enters standby mode, where the input supply current drops to 100 μ A. (Note: C/10 termination is disabled in trickle charging mode).

When charging, transient loads on the BAT pin can cause the PROG pin to fall below 100mV for short periods of time before the DC charge current has dropped to 1/10 the programmed value. The 1ms filter time (T_{TERM}) on the termination comparator ensures that transient loads of this nature do not result in premature charge cycle termination. Once the average charge current drops below 1/10 the programmed value, the BL4054/BL4054B terminates the charge cycle and ceases to provide any current through the BAT pin. In this state, all loads on the BAT pin must be supplied by the battery.

The BL4054 constantly monitors the BAT pin voltage in standby mode. If this voltage drops below the 4.05V recharge threshold (V_{RECHRG}), another charge cycle begins and current is once again supplied to the battery. To manually restart a charge cycle when in standby mode, the input voltage must be removed and reapplied, or the charger must be shut down and restarted using the PROG pin. Figure 1a and 1b shows the state diagram of a typical charge cycle.

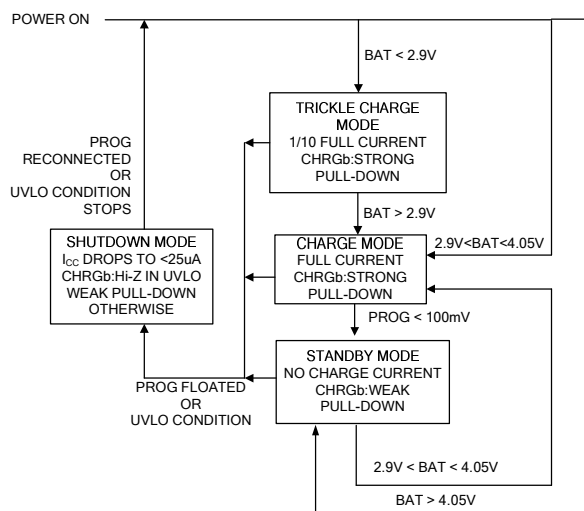

Figure 1a. State Diagram of BL4054 Charge Cycle

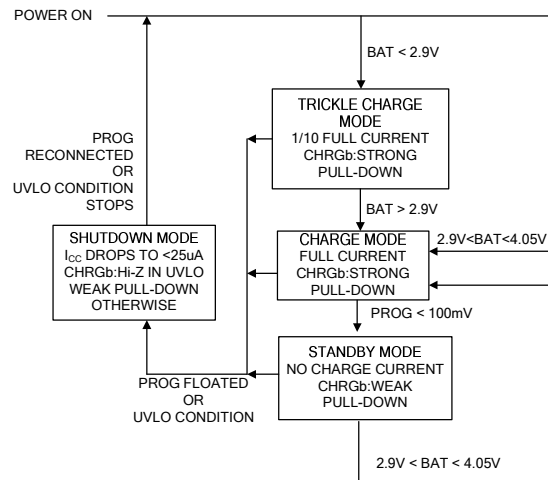

Figure 1b. State Diagram of BL4054B Charge Cycle

Charge Status Indicator (CHRGb)

The charge status output has three different states: strong pull-down ($\sim 10\text{mA}$), weak pull-down ($\sim 12\mu\text{A}$) and high impedance. The strong pull-down state indicates that the BL4054/BL4054B is in a charge cycle. Once the charge cycle has terminated, the pin state is determined by under-voltage lockout conditions. A weak pull-down indicates that V_{CC} meets the UVLO conditions and the BL4054/BL4054B is ready to charge. High impedance indicates that the BL4054/BL4054B is in under voltage lockout mode: either V_{CC} is less than 100mV above the BAT pin voltage or insufficient voltage is applied to the V_{CC} pin. A microprocessor can be used to distinguish between these three states—the application circuit of this method is shown in the Typical Applications section.

Manual Shutdown

At any point in the charge cycle, the BL4054/BL4054B can be put into shutdown mode by removing R_{PROG} thus floating the

PROG pin. This reduces the battery drain current to less than $2\mu\text{A}$ and the supply current to less than $50\mu\text{A}$. A new charge cycle can be initiated by reconnecting the program resistor.

In manual shutdown, the CHRGb pin is in a weak pull-down state as long as V_{CC} is high enough to exceed the UVLO conditions. The CHRGb pin is in a high impedance state if the BL4054/BL4054B is in under voltage lockout mode: either V_{CC} is within 100mV of the BAT pin voltage or insufficient voltage is applied to the V_{CC} pin.

Over-Voltage Protect

The BL4054/BL4054B has an internal Over-Voltage Protect comparator, once the input voltage V_{CC} rises above 7V (V_{OVP}), this comparator will shut down the chip. This feature can prevent the BL4054/BL4054B from the over-voltage stress due to the input transient at hot plug in. In this state, the CHRGb pin will be high impedance. Once the V_{CC} falls back to safe range ($V_{\text{OVP}} - V_{\text{OVP, HYS}}$), normal operation continues.

Automatic Recharge

Once the charge cycle is terminated, the BL4054/BL4054B continuously monitors the voltage on the BAT pin using a comparator with a 2ms filter time (T_{RECHRG}). A charge cycle restarts when the battery voltage falls below 4.05V (which corresponds to approximately 80% to 90% battery capacity). This ensures that the battery is kept at or near a fully charged condition and eliminates the need for periodic charge cycle initiations. CHRGb output enters a strong pull-down state during recharge cycles.

Applications Information

Stability Considerations

The constant-voltage mode feedback loop is stable without an output capacitor provided a battery is connected to the charger output. With no battery present, an output capacitor is recommended to reduce ripple voltage. When using high value, low ESR ceramic capacitors, it is recommended to add a 1Ω resistor in series with the capacitor. No series resistor is needed if tantalum capacitors are used.

In constant-current mode, the PROG pin is in the feedback loop, not the battery. The constant-current mode stability is affected by the impedance at the PROG pin. With no additional capacitance on the PROG pin, the charger is stable with program resistor values as high as 20k. However, additional capacitance on this node reduces the maximum allowed program resistor thus it should be avoided.

Average, rather than instantaneous, charge current may be of interest to the user. For example, if a switching power supply operating in low current mode is connected in parallel with the battery, the average current being pulled out of the BAT pin is typically of more interest than the instantaneous current pulses. In such a case, a simple RC filter can be used on the PROG pin to measure the average battery current as shown in Figure 2. A 10k resistor has been added between the PROG pin and the filter capacitor to ensure stability.

Thermal Limiting

An internal thermal feedback loop reduces the programmed charge current if the die

temperature attempts to rise above a preset value of approximately 120°C. This feature protects the BL4054/BL4054B from excessive temperature and allows the user to push the limits of the power handling capability of a given circuit board without risk of damaging the BL4054/BL4054B. The charge current can be set according to typical (not worst-case) ambient temperature with the assurance that the charger will automatically reduce the current in worst-case conditions.

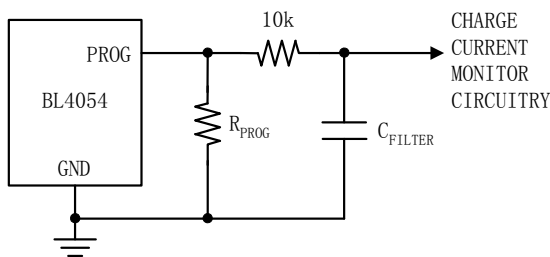

Figure 2. Isolating Capacitive Load on PROG Pin

Power Dissipation

The conditions that cause the BL4054/BL4054B to reduce charge current through thermal feedback can be approximated by considering the power dissipated in the IC. Nearly all of this power dissipation is generated by the internal MOSFET—this is calculated to be approximately:

$$P_D = (V_{CC} - V_{BAT}) \cdot I_{BAT}$$

where P_D is the power dissipated, V_{CC} is the input supply voltage, V_{BAT} is the battery voltage and I_{BAT} is the charge current. The approximate ambient temperature at which the thermal feedback begins to protect the IC is:

$$T_A = 120^\circ\text{C} - P_D \cdot \theta_{JA}$$

$$T_A = 120^\circ\text{C} - (V_{CC} - V_{BAT}) \cdot I_{BAT} \cdot \theta_{JA}$$

Example: An BL4054/BL4054B operating

from a 5V USB supply is programmed to supply 400mA full-scale current to a discharged Li-Ion battery with a voltage of 3.75V. Assuming θ_{JA} is 150°C/W, the ambient temperature at which the BL4054/BL4054B will begin to reduce the charge current is approximately:

$$T_A = 120^\circ\text{C} - (5\text{V} - 3.75\text{V}) \cdot 400\text{mA} \cdot 150^\circ\text{C}/\text{W}$$

$$T_A = 45^\circ\text{C}$$

The BL4054/BL4054B can be used above 45°C ambient, but the charge current will be reduced from 400mA. The approximate current at a given ambient temperature can be approximated by:

$$I_{BAT} = \frac{120^\circ\text{C} - T_A}{(V_{CC} - V_{BAT}) \cdot \theta_{JA}}$$

Using the previous example with an ambient temperature of 60°C, the charge current will be reduced to approximately:

$$I_{BAT} = \frac{120^\circ\text{C} - 60^\circ\text{C}}{(5\text{V} - 3.75\text{V}) \cdot 150^\circ\text{C}/\text{W}} = 320\text{mA}$$

Moreover, when thermal feedback reduces the charge current, the voltage at the PROG pin is also reduced proportionally as discussed in the Operation section.

It is important to remember that BL4054/BL4054B applications do not need to be designed for worst-case thermal conditions since the IC will automatically reduce power dissipation when the junction temperature reaches approximately 120°C.

Thermal Considerations

Because of the small size of the ThinSOT package, it is very important to use a good

thermal PC board layout to maximize the available charge current. The thermal path for the heat generated by the IC is from the die to the copper lead frame, through the package leads, (especially the ground lead) to the PC board copper. The PC board copper is the heat sink. The footprint copper pads should be as wide as possible and expand out to larger copper areas to spread and dissipate the heat to the surrounding ambient. Feed-through vias to inner or backside copper layers are also useful in improving the overall thermal performance of the charger. Other heat sources on the board, not related to the charger, must also be considered when designing a PC board layout because they will affect overall temperature rise and the maximum charge current.

The following table lists thermal resistance for several different board sizes and copper areas.

All measurements were taken in still air on 3/32" FR-4 board with the device mounted on topside.

Table 1. Measured Thermal Resistance (2-Layer Board*)

COPPER AREA		BOARD AREA	THERMAL RESISTANCE JUNCTION-TO-AMBIENT
TOPSIDE	BACKSIDE		
2500mm ²	2500mm ²	2500mm ²	125°C/W
1000mm ²	2500mm ²	2500mm ²	125°C/W
225mm ²	2500mm ²	2500mm ²	130°C/W
100mm ²	2500mm ²	2500mm ²	135°C/W
50mm ²	2500mm ²	2500mm ²	150°C/W

Each layer uses one ounce copper

Table 2. Measured Thermal Resistance (4-Layer Board**)

COPPER AREA (EACH SIDE)	BOARD AREA	THERMAL RESISTANCE JUNCTION-TO-AMBIENT
2500mm ² ***	2500mm ²	80°C/W

**Top and bottom layers use two ounce copper, inner layers use one ounce copper
 ***10,000mm² total copper area

Vcc Bypass Capacitor

Many types of capacitors can be used for input bypassing, however, caution must be exercised when using multilayer ceramic capacitors. Because of the self-resonant and high Q characteristics of some types of ceramic capacitors, high voltage transients can be generated under some start-up conditions, such as connecting the charger input to a live power source. Adding a 1 Ω resistor in series with an X5R ceramic capacitor will minimize start-up voltage transients.

Charge Current Soft-Start

The BL4054/BL4054B includes a soft-start circuit to minimize the inrush current at the start of a charge cycle. When a charge cycle is initiated, the charge current ramps from zero to the full-scale current over a period of approximately 50μs. This has the effect of minimizing the transient current load on the power supply during start-up.

Typical Applications

USB/Wall Adapter Power Li-Ion Charger

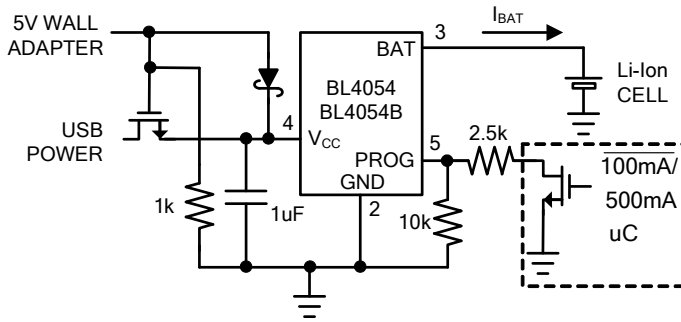

Full Featured Single Cell Li-Ion Charger

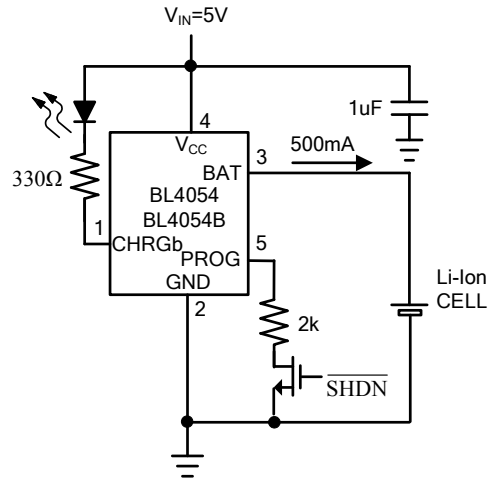

Using a Microprocessor to Determine CHRGb State

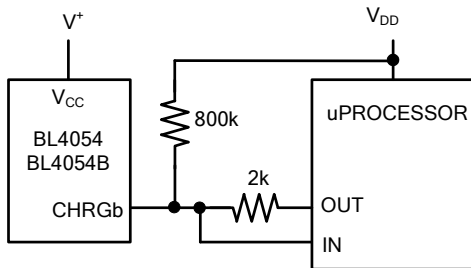

Basic Li-Ion Charger with Reverse Polarity Input Protection

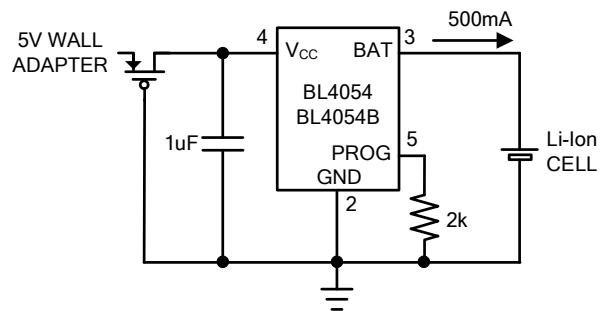

800mA Li-Ion Charger with External Power Dissipation

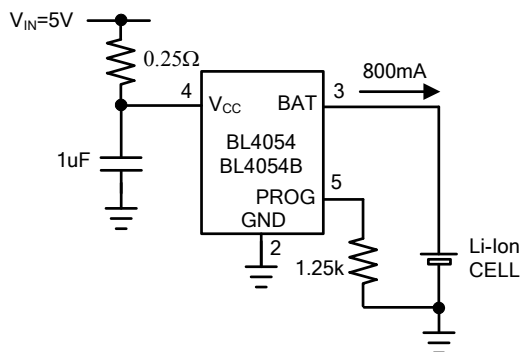

Package Description

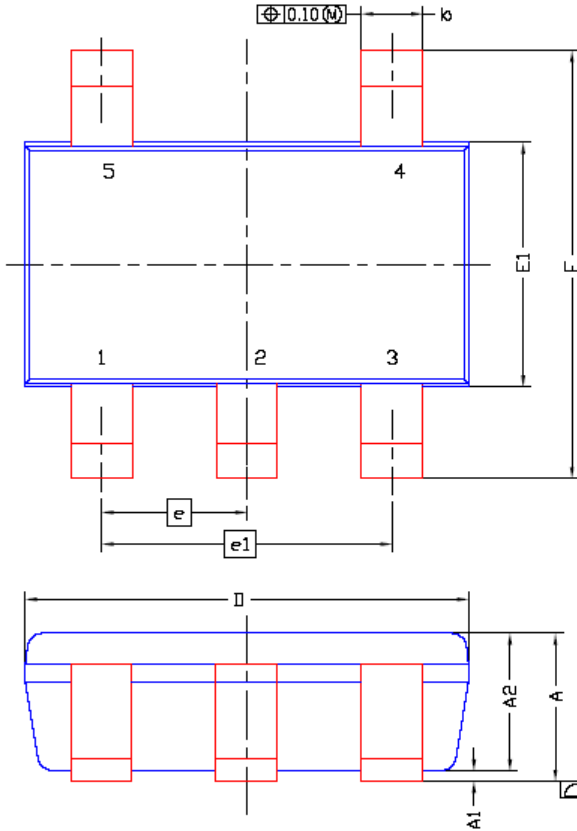

DIM.	MILLIMETERS			INCHES		
	MIN	NOM	MAX	MIN	NOM	MAX
A	0.80	0.95	1.00	0.0315	0.0374	0.0394
A1	0.00	---	0.10	0.000	---	0.004
A2	0.70	0.875	0.90	0.0276	0.0344	0.0354
k	0.35	0.40	0.50	0.014	0.016	0.020
c	0.10	0.127	0.20	0.004	0.005	0.008
D	2.90 BSC			0.114 BSC		
E	2.80 BSC			0.110 BSC		
E1	1.60 BSC			0.063 BSC		
e	0.95 BSC			0.037 BSC		
e1	1.90 BSC			0.075 BSC		
L	0.30	0.40	0.60	0.0118	0.0157	0.024
L1	0.60REF			0.024REF		
L2	0.254BSC			0.010BSC		
R	0.10	---	---	0.004	---	---
θ	0°	4°	8°	0°	4°	8°
θ1	7°NOM			7°NOM		

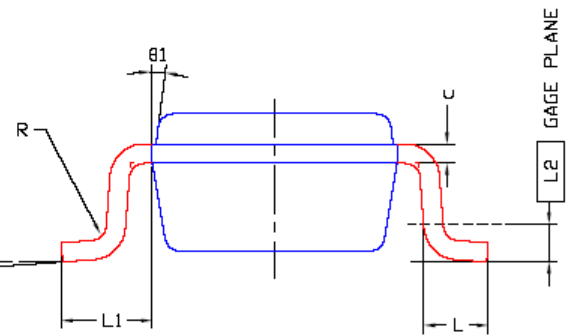

TSOT-23-5 Surface Mount Package

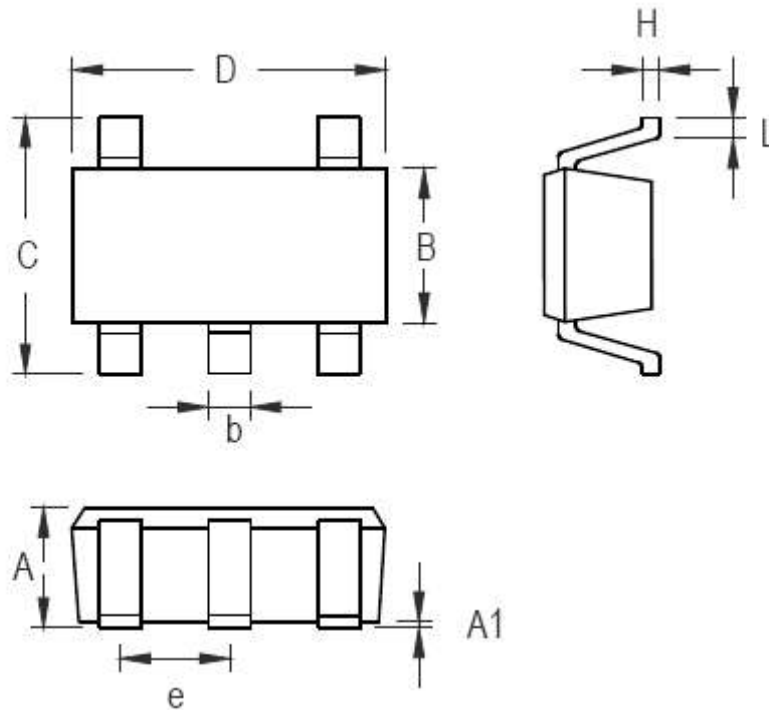

Symbol	Dimensions In Millimeters		Dimensions In Inches	
	Min	Max	Min	Max
A	0.889	1.295	0.035	0.051
A1	0.000	0.152	0.000	0.006
B	1.397	1.803	0.055	0.071
b	0.356	0.559	0.014	0.022
C	2.591	2.997	0.102	0.118
D	2.692	3.099	0.106	0.122
e	0.838	1.041	0.033	0.041
H	0.080	0.254	0.003	0.010
L	0.300	0.610	0.012	0.024

SOT-23-5 Surface Mount Package

单击下面可查看定价，库存，交付和生命周期等信息

[>>BELLING\(上海贝岭\)](#)