

High Efficiency 1.2MHz 30V Boost

DESCRIPTION

BL8041 is a step-up converter. Its 1.23V feedback voltage reduces power loss and improves efficiency.

Optimized operation frequency can meet the requirement of small LC filters value and low operation current with high efficiency. Internal soft start function can reduce the inrush current. Tiny package type provides the best solution for PCB space saving and total BOM cost.

BL8041 is available in SOT23-5 package that is Pb free.

FEATURES

- 2.5V to 5.5V Input Voltage
- 1.23V Feedback Voltage
- 1.2MHz Fixed Switching Frequency
- Internal 0.6A Switch Current Limit
- Internal Compensation
- Thermal Shutdown
- Available in SOT23-5 Package

APPLICATIONS

- Camera Flash White LED
- PDA LED back light
- Digital still cameras

TYPICAL APPLICATION

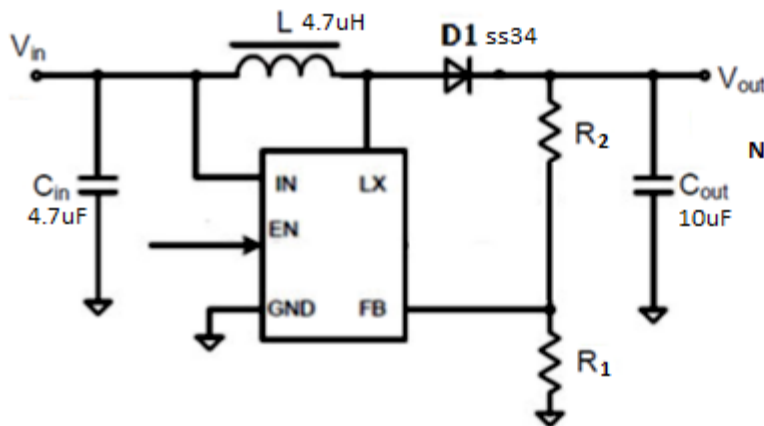

Note: 1) $V_{out} = \frac{1.23V}{R_1} \times (R_1 + R_2)$

2) The decoupling capacitors C_{in} should be placed as close to the IC as possible.

3) The inductance ($L=10\mu H$) is recommended when the load current is more than 200mA, otherwise it should be 4.7uH.

Figure1. BL8041 Typical Application Circuit

ORDERING INFORMATION

BL8041 ①②③

Code	Description
1	Temperature & Rohs: C: -40~85°C, Pb Free Rohs Std.
2	Package Type: B5: SOT-23-5
3	Packing Type: TR: Tape & Reel (Standard)

MARKING INFORMATION

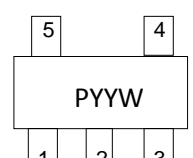
Product Classification		BL8041CB5TR
Marking		
PYYW	PY: Product Code	
	YW: Date Code	

PIN DESCRIPTION

Pin No.	Symbol	Description
1	LX	Power Switch Output. LX is the drain of the internal MOSFET switch. Connect the power inductor and output rectifier to LX. LX can swing between GND and 30V.
2	GND	Ground
3	FB	Feedback Input. The FB voltage is 0.25V. Connect a resistor divider to FB.
4	EN	Regulator On/Off Control Input. A high input at EN turns on the converter, and a low input turns it off. When not used, connect EN to the input supply for automatic startup.
5	IN	Power Supply. Must be locally bypassed.

ABSOLUTE MAXIMUM RATING

Parameter	Value
IN, EN Pin Voltage	-0.3V to 6V
SW Pin Voltage	-0.3V to 30V
All Other Pin Voltage	-0.3V to 6V
Junction Temperature (T _J)	150°C
Ambient Temperature (T _A)	-40°C to 85°C
Power Dissipation	600mW
Thermal Resistance (θ _{JA})	SOT23-5
Thermal Resistance (θ _{JC})	
Storage Temperature (T _S)	130°C/W
Lead Temperature & Time	-65°C to 150°C
	260°C, 10Sec

RECOMMENDED WORK CONDITIONS

Parameter	Value
Input Voltage Range	2.5V to 5.5V
Output Voltage Range	V _{IN} to 30V
Operating Junction Temperature(T _J)	-40°C –125°C

ELECTRICAL CHARACTERISTICS

(T_a=25°C, unless otherwise noted)

Symbol	Item	Conditions	Min.	Typ.	Max.	Unit
V _{IN}	Operating Input Voltage		2.5		5.5	V
V _{FB}	Feedback Voltage		1.21	1.23	1.25	V
I _{FB}	FB input Bias Current	V _{FB} =1V	-50	-10		nA
	SW Leakage	V _{SW} =20V			1	uA
I _Q	Quiescent Current	V _{FB} =1V, Switch		0.15	0.3	mA
		V _{EN} =0V		0.1	1	uA
F _{SW}	Oscillator Frequency			1.2		MHz
D _{MAX}	Maximum Duty Cycle			90		%
V _{EN}	EN Threshold			1		V
	SW On-Resistance			400	650	mΩ
I _{LIMIT}	Current Limit	V _{IN} =4V, Duty Cycle = 50%		0.6		A
	Thermal Shutdown			160		°C

TYPICAL PERFORMANCE CHARACTERISTICS

Efficiency Vout=5V

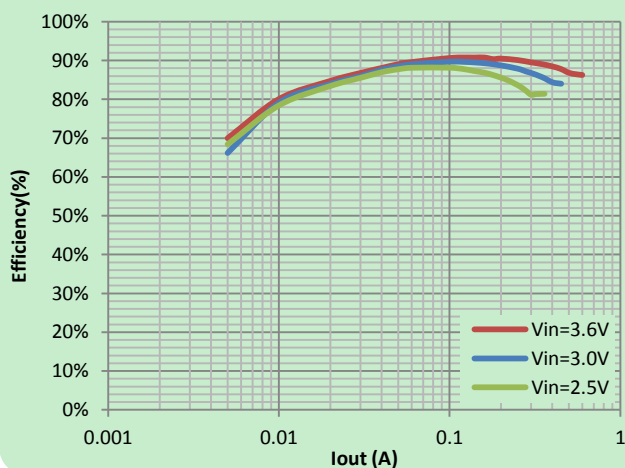

Efficiency Vout=12V

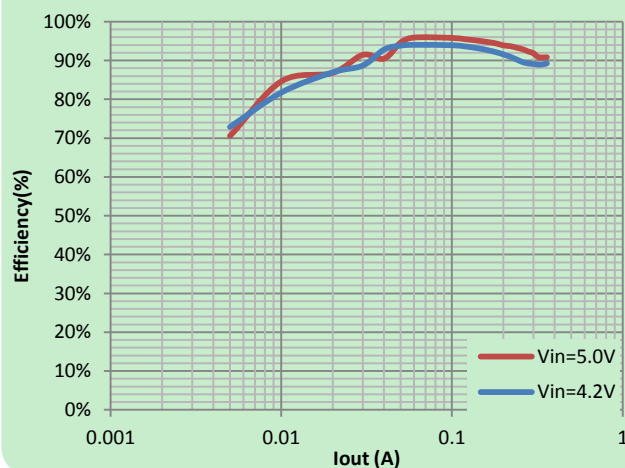

Efficiency Vout=18V

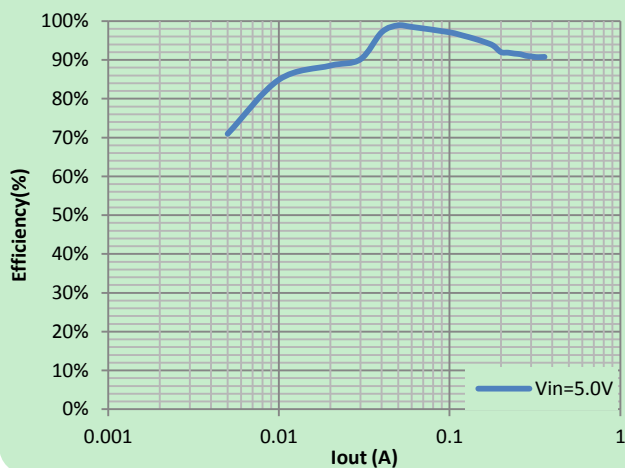

Output Voltage vs. Output Current

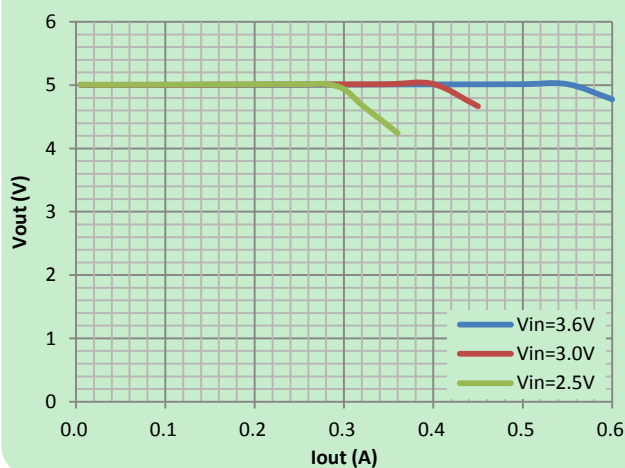

Output Voltage vs. Output Current

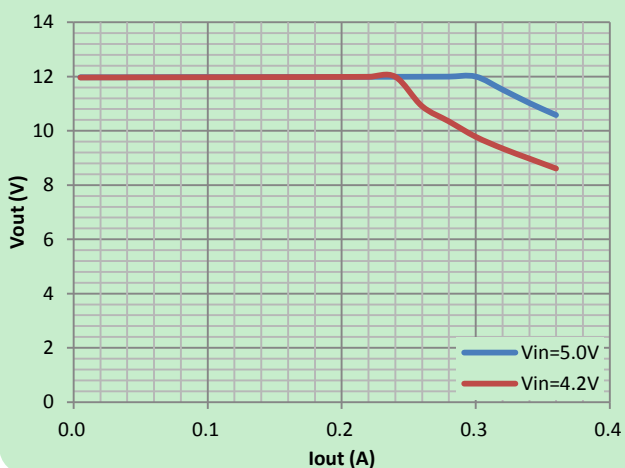

Output Voltage vs. Output Current

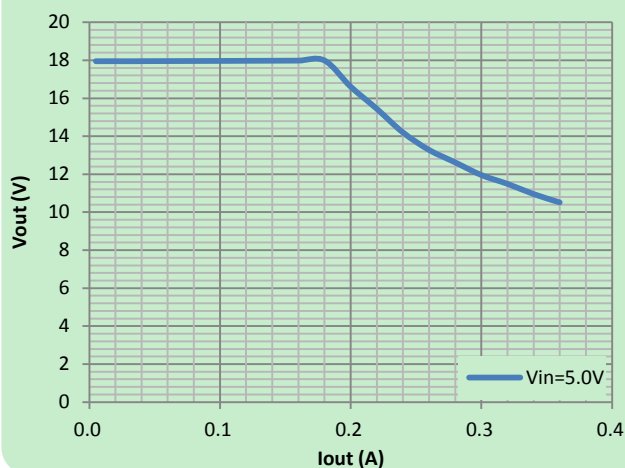

Switching Waveform

Vin=5V, Vout=12V, Iout=200mA
(CH1=Vin, CH2=Vout, CH3=LX, CH4=ILX)

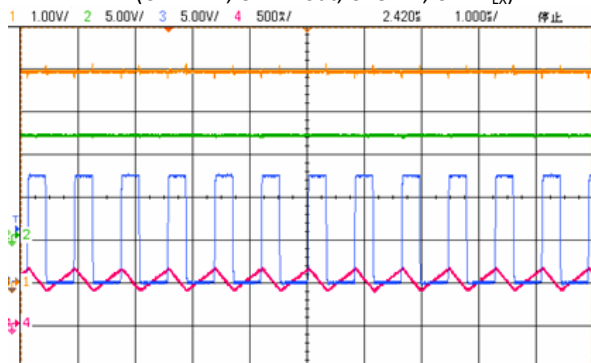

Switching Waveform

Vin=5V, Vout=18V, Iout=150mA
(CH1=Vin, CH2=Vout, CH3=LX, CH4=ILX)

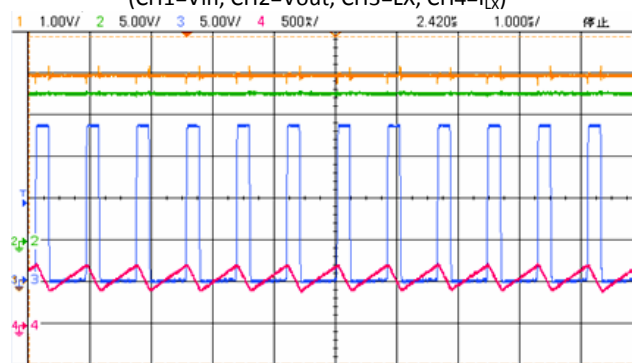

Load Transient Response

Vin=5V, Vout=12V, Iout=10mA-200mA
(CH2=Vout, CH4=ILX)

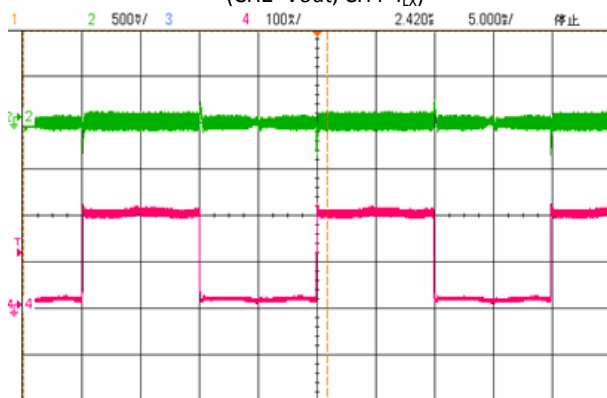

Switching waveform

Vin=5V, Vout=18V, Iout=10mA-150mA
(CH2=Vout, CH4=ILX)

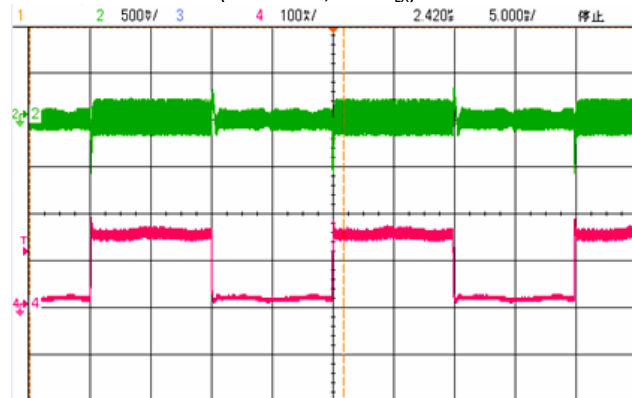

PACKAGE INFORMATION

Package	SOT-23-5	Devices per reel	3000Pcs	Unit	mm
---------	----------	------------------	---------	------	----

Package Dimension:

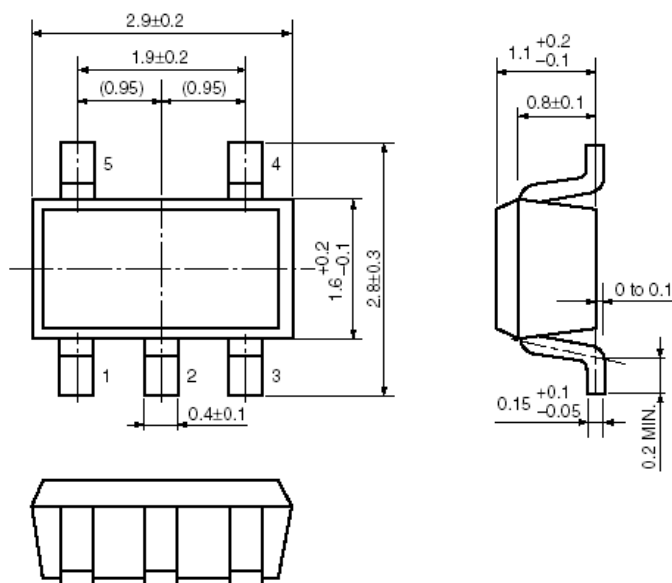

单击下面可查看定价，库存，交付和生命周期等信息

[>>BELLING\(上海贝岭\)](#)