

Features

- 7pin SIP Package with Industry-Standard Footprint
- Input / Output Isolation Voltage: 3kVDC
- High Efficiency
- Lead Free Design, RoHS Compliant
- Operating temperature: -40°C to +105°C
- Meet Safety Standard / Approval: IEC / EN60950-1

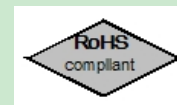
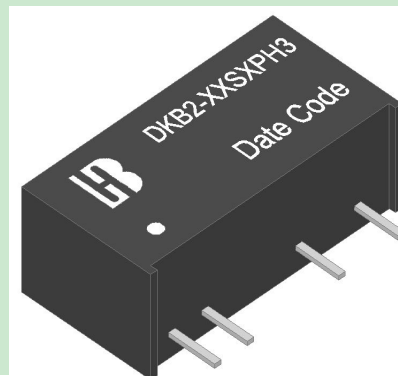

Applications

These converters are well suitable for battery operated equipment, measurement equipment, telecom, wireless network, Industry control system, everywhere where isolated, tightly regulated voltages and compact size are required.

Technical Specification All specifications are typical at nominal input, full load and 25°C unless otherwise stated.

Model Number	Input Voltage Range(V)	Output Voltage (V)	Output Current (mA) ⁽¹⁾		Input Current (mA) Typ.		Eff. (%) ⁽²⁾ Typ.	Capacitive Load, max. ⁽³⁾ (uF)
			Full Load	No Load	No Load	Full Load		
DKB2-05S0PH3	4.5-5.5 Nominal:5	3.3	400	35	338	78	68	
DKB2-05S1PH3		5	400		500	80	47	
DKB2-05SAPH3		9	220		477	83	33	
DKB2-05S2PH3		12	166		475	84	22	
DKB2-05S3PH3		15	133		475	84	22	
DKB2-05S5PH3		24	83		475	84	10	
DKB2-05SLPH3		25	80		475	84	10	
DKB2-05D0PH3		±3	±200		338	78	33/33	
DKB2-05D1PH3		±5	±200		500	80	22/22	
DKB2-05DAPH3		±9	±110		477	83	10/10	
DKB2-05D2PH3		±12	±83		475	84	10/10	
DKB2-05D3PH3		±15	±66		475	84	10/10	
DKB2-05D5PH3		±24	±42		475	84	4.7/4.7	
DKB2-12S0PH3		10.8-13.2 Nominal:12	3.3		400	15	143	77
DKB2-12S1PH3	5		400	208	80		47	
DKB2-12SAPH3	9		220	199	83		33	
DKB2-12S2PH3	12		166	198	84		22	
DKB2-12S3PH3	15		133	198	84		22	
DKB2-12S5PH3	24		83	198	84		10	
DKB2-12D0PH3	±3.3		±200	143	77		33/33	
DKB2-12D1PH3	±5		±200	208	80		22/22	
DKB2-12DAPH3	±9		±110	199	83		10/10	
DKB2-12D2PH3	±12		±83	198	84		10/10	
DKB2-12D3PH3	±15		±66	198	84		10/10	

Model Number	Input Voltage Range(V)	Output Voltage (V)	Output Current (mA) ⁽¹⁾	Input Current (mA) Typ.		Eff. (%) ⁽²⁾ Typ.	Capacitive Load, max. ⁽³⁾ (uF)
				No Load	Full Load		
DKB2-15S0PH3	13.5-16.5 Nominal:15	3.3	400	12	114	77	68
DKB2-15S1PH3		5	400		167	80	47
DKB2-15SAPH3		9	220		159	83	33
DKB2-15S2PH3		12	166		158	84	22
DKB2-15S3PH3		15	133		158	84	22
DKB2-15S5PH3		24	83		158	84	10
DKB2-15D0PH3		±3.3	±200		114	77	33/33
DKB2-15D1PH3		±5	±200		167	80	22/22
DKB2-15DAPH3		±9	±110		159	83	10/10
DKB2-15D2PH3		±12	±83		158	84	10/10
DKB2-15D3PH3		±15	±66		158	84	10/10
DKB2-24S0PH3		21.6-26.4 Nominal:24	3.3		400	8	71
DKB2-24S1PH3	5		400	104	80		47
DKB2-24SAPH3	9		220	99	83		33
DKB2-24S2PH3	12		166	99	84		22
DKB2-24S3PH3	15		133	99	84		22
DKB2-24S5PH3	24		83	99	84		10
DKB2-24D0PH3	±3.3		±200	71	77		33/33
DKB2-24D1PH3	±5		±200	104	80		22/22
DKB2-24DAPH3	±9		±110	99	83		10/10
DKB2-24D2PH3	±12		±83	99	84		10/10
DKB2-24D3PH3	±15		±66	99	84		10/10

Input Specifications

5V nominal input	4.5-5.5V
12V nominal input	10.8-13.2V
15V nominal input	13.5-16.5V
24V nominal input	21.6-26.4V

Input filter Capacitor

Environmental Specifications

Operating ambient temperature	-40°C to +105°C
Maximum case temperature	+125°C
Storage temperature range	-55°C to +125°C
Relative humidity	95% RH max.

Output Specifications

Output power		2Watts max.
Voltage accuracy	Nominal Vin and full load	
	3.3Vdc	3.135-3.399V
	5Vdc	4.75-5.15V
	9Vdc	8.73-9.18V
	12Vdc	11.64-12.24V
	15Vdc	14.55-15.30V
	24Vdc	23.52-24.36V
25Vdc	24.50-25.37V	
Voltage balance	Dual output	±1% max.
Minimum load		10% load of full load
Line regulation	For Vin change of 1%	±1.2% Typ.
Load regulation	Nominal Vin and 10%-100% load	
	3.3Vdc	15% Typ.
	5Vdc	13% Typ.
	9Vdc	9% Typ.
	12Vdc	8% Typ.
	15Vdc	7% Typ.
	24Vdc	6% Typ.
25Vdc	6% Typ.	
Ripple and Noise (20MHz Bandwidth)		100mVp-p Typ. 150mVp-p Max.
Maximum capacitive load		See table
Output short circuit protection	DKB2-24SXP3/DKB2-24DXPH3	3S Max.
	Other models	Continuous, Automatic recovery
Temperature coefficient		±0.03%/°C Typ.

General Specifications

Efficiency	Nominal input and full load	See table
Isolation voltage	Input to output	3000VDC (60 second)
Isolation resistance	500VDC	1000MΩ min.
Isolation capacitance		30pF typ.
Switching frequency		150kHz typ.
		300kHz max.
Reliability, calculated MTBF		2×10 ⁶ Hrs

Physical Specifications

Case material		Plastic (UL94 V-0)
Potting material		Epoxy (UL94 V-0)
Dimensions		19.6× 10.1× 7.0 mm
Weight		2.5g Typ.

Note

1. Io below this value will not damage these converters, however, they may not meet all listed specifications.
2. Typical value, tested at nominal input and full load.
3. For each output.
4. Specifications subject to change without notice.
5. This series of products do not support CC mode, CR mode is recommended.
6. In case of long input lines or hot plug-in requirements, we recommended to use an external low ESR capacitor (22uF) near to the converter's input pins.

Power Derating Curve

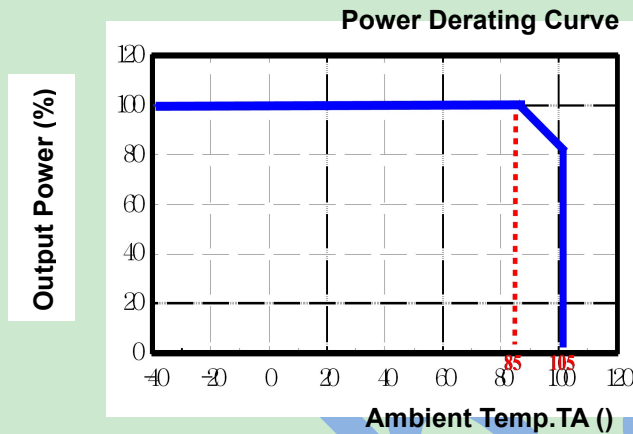

Mechanical Dimensions

Single output

Dual output

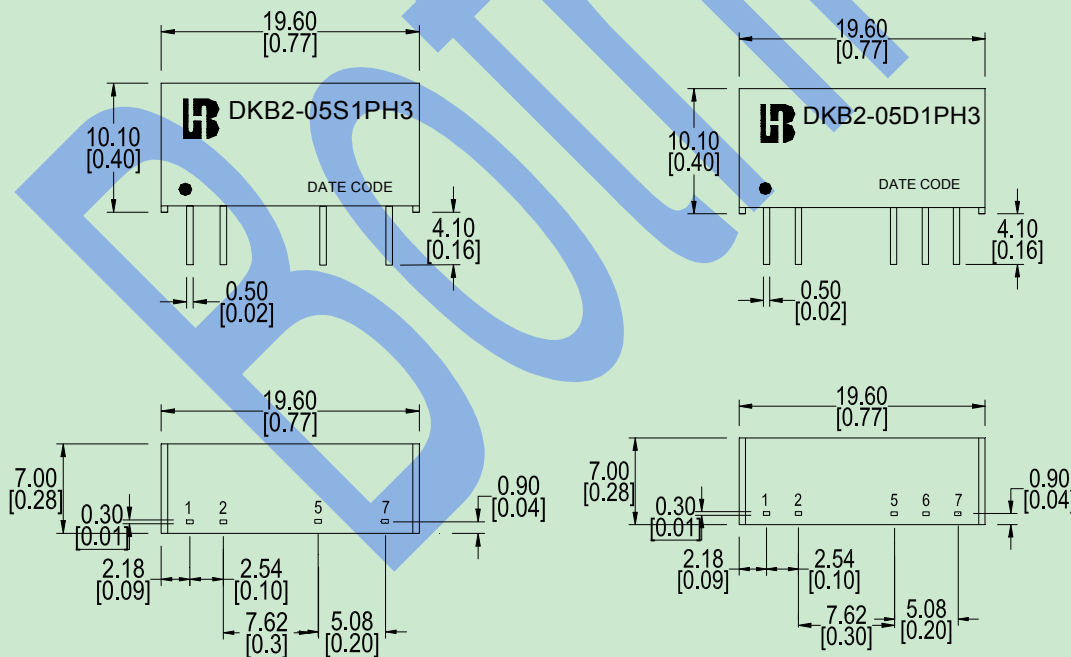

Pin Assignment		
Pin	Single	Dual
1	+Vin	+Vin
2	-Vin	-Vin
5	-Vout	-Vout
6	No pin	Common
7	+Vout	+Vout

Unit: mm (inch)
 Pin section tolerances: $\pm 0.1 (\pm 0.004)$
 General tolerances: $\pm 0.5 (\pm 0.02)$

Test Configurations

All specifications are typical at nominal input, full load and 25°C unless otherwise stated.

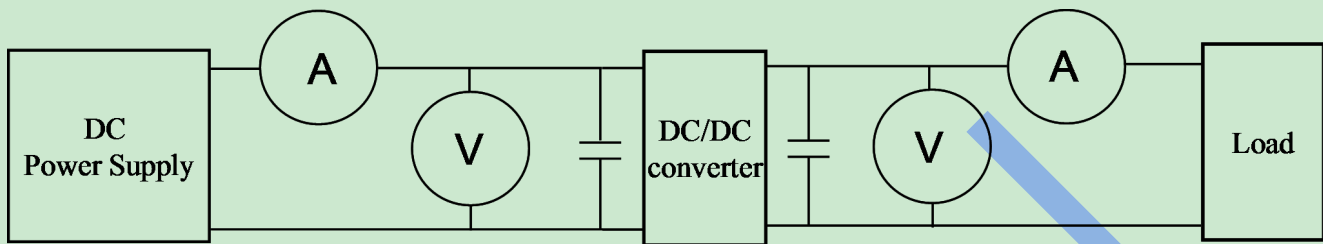

©DC Power Supply: It offers a wide voltage and current range precisely.

©Current meter (A): Accuracy → 200μA ~ 200mA 4 ranges ±(0.2% rdg + 2 digits)

2000mA ~ 20A 2 ranges ±(0.3% rdg + 2 digits).

©Voltage meter (V): Accuracy → ±(0.03% rdg + 4 digits).

©Load: At full load.

©Wires: The resistance of the wires must be small.

1. Input voltage range: Narrow input voltage range (±10%)、wide input voltage range (2:1 and 4:1)。

EX: Narrow input voltage range (±10%)

5V nominal input	→	4.5~5.5V
12V nominal input	→	10.8~13.2V
24V nominal input	→	21.6~26.4V

Wide input voltage range 2:1

5V nominal input	→	4.5~9V
12V nominal input	→	9~18V
24V nominal input	→	18~36V
48V nominal input	→	36~75V

Wide input voltage range 4:1 (W)

24V nominal input	→	9~36V
48V nominal input	→	18~75V

2. Input power :

$$P_{in} = V_{in} \times I_{in}$$

V_{in} : Input voltage

I_{in} : Input current

3. Output power :

$$P_{out} = V_{out} \times I_{out}$$

V_{out} : Output voltage

I_{out} : Output current

4. Efficiency :

$$\text{Efficiency} = \frac{P_{out}}{P_{in}} \times 100\%$$

P_{out} : Output power

P_{in} : Input power

5. Voltage accuracy:

$$\frac{|V_{out} - V_{out(nominal)}|}{V_{out}} \times 100\%$$

V_{out} : Output voltage

$V_{out(nominal)}$: Nominal output voltage

6. Line regulation:

Narrow input voltage range ($\pm 10\%$) and unregulated output voltage series.

$$\text{Line regulation} = \frac{\Delta V_{out}}{\Delta V_{in}}$$

$$\Delta V_{out} = \frac{V_{out(+10\%)} - V_{out(-10\%)}}{V_{out}} \times 100\%$$

$V_{out(+10\%)}$: Output voltage at $V_{in} = 1.1 \times V_{in}(\text{nominal})$ & full load

$V_{out(-10\%)}$: Output voltage at $V_{in} = 0.9 \times V_{in}(\text{nominal})$ & full load

V_{out} : Output voltage at $V_{in} = V_{in}(\text{nominal})$ & full load

$$\Delta V_{in} = \frac{V_{in(+10\%)} - V_{in(-10\%)}}{V_{in}(\text{nominal})} \times 100\%$$

$V_{in(+10\%)}$: Input voltage = $1.1 \times V_{in}(\text{nominal})$

$V_{in(-10\%)}$: Input voltage = $0.9 \times V_{in}(\text{nominal})$

$V_{in}(\text{nominal})$: Nominal Input voltage

7. Load regulation :

$$\frac{|V_{out(FL)} - V_{out(NL)}|}{V_{out(FL)}} \times 100\%$$

$V_{out(FL)}$: Output voltage at full load

$V_{out(NL)}$: Output voltage at 25% full load or 10% full load

8. Ripple and Noise: as shown below. The bandwidth is 0-20MHz.

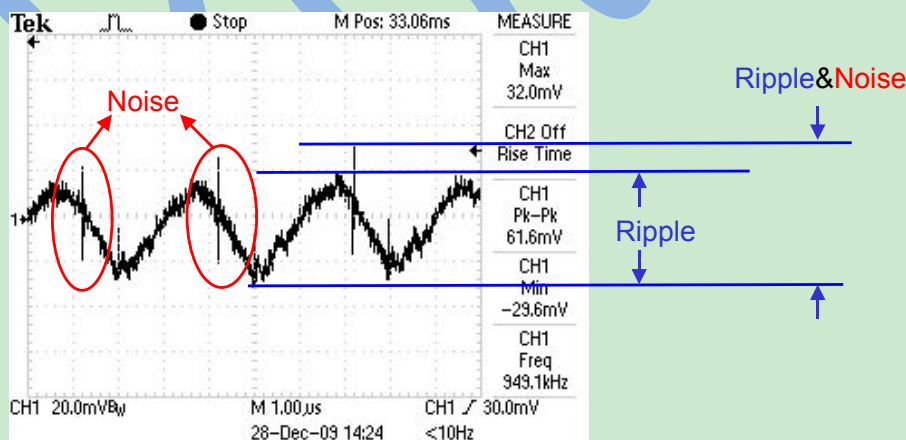

Output Ripple&Noise measurement test circuit: as shown below.

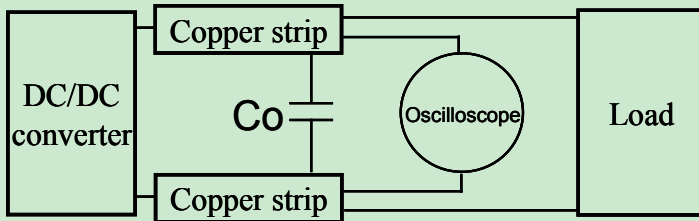

Co: usually 0.47uF.

9. **Temperature derating curve:** The DC-DC converter will operate over a wider temperature range if less power is drawn from the output and the device is already running. The temperature derating curve shows the operating power-temperature range. As shown below.

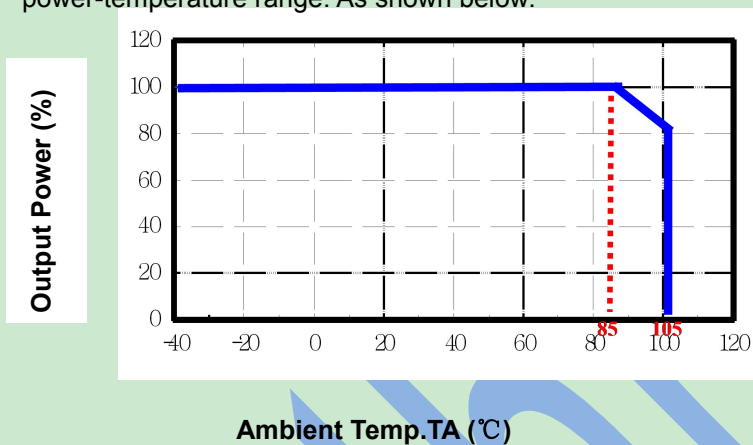

10. **Switching frequency:** The nominal operating frequency of the DC-DC converters.
11. **Input to output isolation:** The dielectric breakdown strength test between input and output circuits. This is the isolation voltage the device is capable of withstanding for a specified time, usually 1 second or 1 minute.
12. **Input source impedance:** The power module should be connected to low ac-impedance input source.

Highly inductive source impedances can affect the stability of the power module. In applications where power is supplied over long lines and output loading is high, it may be necessary to use a capacitor at the input to ensure startup. Capacitor mounted close to the power module helps ensure stability of the unit, it is commended to use a good quality low Equivalent Series Resistance (ESR <math>< 0.1\Omega</math> at 100KHz) capacitor of a 22uF for the power module.

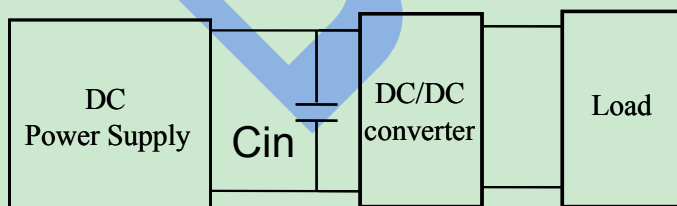

单击下面可查看定价，库存，交付和生命周期等信息

[>>Bothhand\(帛汉\(帛漠\)\)](#)