

## Transient Voltage Suppressors (TVS) Data Sheet

### Features

- For surface mounted applications in order to optimize board space
- Low profile package
- Glass passivated junction
- Low inductance
- Excellent clamping capability
- 400W peak pulse power capability at 10/1000 $\mu$ s waveform, repetition rate (duty cycle): 0.01%
- Fast response time
- Typical  $I_R$  less than 1 $\mu$ A above 10V
- High Temperature soldering: 260 $^{\circ}$ C/10 seconds at terminals
- Plastic package has underwriters laboratory flammability 94V-0
- Meets MSL level 1, per J-STD-020
- Safety certification: UL: E244458
- AEC-Q101 qualified



### Mechanical Data

- Case: JEDEC DO-214AC. Molded plastic over glass passivated junction
- Terminal: Solder plated, solderable per MIL-STD-750, Method 2026
- Polarity: Color band denotes cathode except bi-directional models
- Standard Packaging: 12mm tape (EIA STD RS-481)
- Weight: 0.07g

### Applications

- I/O interface
- AC/DC power supply
- Low frequency signal transmission line (RS232, RS485, etc.)

### Maximum Ratings and Characteristics

Ratings at 25 $^{\circ}$ C ambient temperature unless otherwise specified.

Rating	Symbol	Value	Units
Peak pulse power dissipation at 10/1000 $\mu$ s waveform (Note1, Note2, Fig.1)	$P_{PPM}$	Minimum 400	Watts
Peak pulse current of at 10/1000 $\mu$ s waveform (Note 1, Fig.3)	$I_{PPM}$	See Table	Amps
Steady state power dissipation at $T_A=50^{\circ}$ C (Fig.5)	$P_{M(AV)}$	3.3	Watts
Peak forward surge current, 8.3ms single half sine-wave superimposed on rated load, (JEDEC Method) (Note3, Fig.6)	$I_{FSM}$	40	Amps
Operating junction and Storage Temperature Range.	$T_J, T_{STG}$	-55 to +150	$^{\circ}$ C
Typical thermal resistance junction to lead	$R_{\theta JL}$	30	$^{\circ}$ C/W
Typical thermal resistance junction to ambient	$R_{\theta JA}$	120	$^{\circ}$ C/W

Notes: 1. Non-repetitive current pulse, per Fig.3 and derated above  $T_A=25^{\circ}$ C per Fig.2.

2. Mounted on 5.0mm $\times$ 5.0mm (0.03mm thick) copper pads to each terminal.

3. 8.3ms single half sine-wave, or equivalent square wave, duty cycle=4 pulses per minutes maximum.

**Dimensions (SMA/DO-214AC)**

Symbol	Millimeters		Inches	
	Min.	Max.	Min.	Max.
L	3.99	4.50	0.157	0.177
D	2.54	2.79	0.100	0.110
D1	1.25	1.65	0.049	0.065
T	4.93	5.28	0.194	0.208
T1	0.76	1.52	0.030	0.060
d	-	0.203	-	0.008
H	2.00	2.50	0.079	0.098
H1	1.98	2.29	0.078	0.090

**Electrical Characteristics (T<sub>A</sub>=25°C)**

Part Number		Device Marking Code		Reverse Stand-Off Voltage	Breakdown Voltage @I <sub>T</sub>	Test Current	Maximum Clamping Voltage @I <sub>PP</sub>	Peak Pulse Current	Reverse Leakage @V <sub>RWM</sub>
Unidirectional	Bidirectional	UNI	BI	V <sub>RWM</sub> (V)	V <sub>BR</sub> (V)	I <sub>T</sub> (mA)	V <sub>C</sub> (V)	I <sub>PP</sub> (A)	I <sub>R</sub> (μA)
P4SMA6.8A-AT	P4SMA6.8CA-AT	6V8A	6V8C	5.80	6.45~7.14	10	10.5	39.0	1000
P4SMA7.5A-AT	P4SMA7.5CA-AT	7V5A	7V5C	6.40	7.13~7.88	10	11.3	36.3	500
P4SMA8.2A-AT	P4SMA8.2CA-AT	8V2A	8V2C	7.02	7.79~8.61	10	12.1	33.9	200
P4SMA9.1A-AT	P4SMA9.1CA-AT	9V1A	9V1C	7.78	8.65~9.55	1	13.4	30.6	50
P4SMA10A-AT	P4SMA10CA-AT	10A	10C	8.55	9.50~10.50	1	14.5	28.3	10
P4SMA11A-AT	P4SMA11CA-AT	11A	11C	9.40	10.50~11.60	1	15.6	26.3	5
P4SMA12A-AT	P4SMA12CA-AT	12A	12C	10.20	11.40~12.60	1	16.7	24.6	5
P4SMA13A-AT	P4SMA13CA-AT	13A	13C	11.10	12.40~13.70	1	18.2	22.5	1
P4SMA15A-AT	P4SMA15CA-AT	15A	15C	12.80	14.30~15.80	1	21.2	19.3	1
P4SMA16A-AT	P4SMA16CA-AT	16A	16C	13.60	15.20~16.80	1	22.5	18.2	1
P4SMA18A-AT	P4SMA18CA-AT	18A	18C	15.30	17.10~18.90	1	25.2	16.1	1
P4SMA20A-AT	P4SMA20CA-AT	20A	20C	17.10	19.00~21.00	1	27.7	14.8	1
P4SMA22A-AT	P4SMA22CA-AT	22A	22C	18.80	20.90~23.10	1	30.6	13.4	1
P4SMA24A-AT	P4SMA24CA-AT	24A	24C	20.50	22.80~25.20	1	33.2	12.3	1
P4SMA27A-AT	P4SMA27CA-AT	27A	27C	23.10	25.70~28.40	1	37.5	10.9	1
P4SMA30A-AT	P4SMA30CA-AT	30A	30C	25.60	28.50~31.50	1	41.4	9.9	1
P4SMA33A-AT	P4SMA33CA-AT	33A	33C	28.20	31.40~34.70	1	45.7	9.0	1
P4SMA36A-AT	P4SMA36CA-AT	36A	36C	30.80	34.20~37.80	1	49.9	8.2	1
P4SMA39A-AT	P4SMA39CA-AT	39A	39C	33.30	37.10~41.00	1	53.9	7.6	1

Part Number		Device Marking Code		Reverse Stand-Off Voltage	Breakdown Voltage @ $I_T$	Test Current	Maximum Clamping Voltage @ $I_{PP}$	Peak Pulse Current	Reverse Leakage @ $V_{RWM}$
Unidirectional	Bidirectional	UNI	BI	$V_{RWM}(V)$	$V_{BR}(V)$	$I_T(mA)$	$V_C(V)$	$I_{PP}(A)$	$I_R(\mu A)$
P4SMA43A-AT	P4SMA43CA-AT	43A	43C	36.80	40.90~45.20	1	59.3	6.9	1
P4SMA47A-AT	P4SMA47CA-AT	47A	47C	40.20	44.70~49.40	1	64.8	6.3	1
P4SMA51A-AT	P4SMA51CA-AT	51A	51C	43.60	48.50~53.60	1	70.1	5.8	1
P4SMA56A-AT	P4SMA56CA-AT	56A	56C	47.80	53.20~58.80	1	77.0	5.3	1
P4SMA62A-AT	P4SMA62CA-AT	62A	62C	53.00	58.90~65.10	1	85.0	4.8	1
P4SMA68A-AT	P4SMA68CA-AT	68A	68C	58.10	64.60~71.40	1	92.0	4.5	1
P4SMA75A-AT	P4SMA75CA-AT	75A	75C	64.10	71.30~78.80	1	103.0	4.0	1
P4SMA82A-AT	P4SMA82CA-AT	82A	82C	70.10	77.90~86.10	1	113.0	3.6	1
P4SMA91A-AT	P4SMA91CA-AT	91A	91C	77.80	86.50~95.50	1	125.0	3.3	1
P4SMA100A-AT	P4SMA100CA-AT	100A	100C	85.50	95.00~105.00	1	137.0	3.0	1
P4SMA110A-AT	P4SMA110CA-AT	110A	110C	94.00	105.00~116.00	1	152.0	2.7	1
P4SMA120A-AT	P4SMA120CA-AT	120A	120C	102.00	114.00~126.00	1	165.0	2.5	1
P4SMA130A-AT	P4SMA130CA-AT	130A	130C	111.00	124.00~137.00	1	179.0	2.3	1
P4SMA150A-AT	P4SMA150CA-AT	150A	150C	128.00	143.00~158.00	1	207.0	2.0	1
P4SMA160A-AT	P4SMA160CA-AT	160A	160C	136.00	152.00~168.00	1	219.0	1.9	1
P4SMA170A-AT	P4SMA170CA-AT	170A	170C	145.00	162.00~179.00	1	234.0	1.8	1
P4SMA180A-AT	P4SMA180CA-AT	180A	180C	154.00	171.00~189.00	1	246.0	1.7	1
P4SMA200A-AT	P4SMA200CA-AT	200A	200C	171.00	190.00~210.00	1	274.0	1.5	1
P4SMA220A-AT	P4SMA220CA-AT	220A	220C	185.00	209.00~231.00	1	328.0	1.3	1
P4SMA250A-AT	P4SMA250CA-AT	250A	250C	214.00	237.00~263.00	1	344.0	1.2	1
P4SMA300A-AT	P4SMA300CA-AT	300A	300C	256.00	285.00~315.00	1	414.0	1.0	1
P4SMA350A-AT	P4SMA350CA-AT	350A	350C	300.00	332.00~368.00	1	482.0	0.9	1
P4SMA400A-AT	P4SMA400CA-AT	400A	400C	342.00	380.00~420.00	1	548.0	0.8	1
P4SMA440A-AT	P4SMA440CA-AT	440A	440C	376.00	418.00~462.00	1	602.0	0.7	1
P4SMA480A-AT	P4SMA480CA-AT	480A	480C	408.00	456.00~504.00	1	658.0	0.6	1
P4SMA510A-AT	P4SMA510CA-AT	510A	510C	434.00	485.00~535.00	1	698.0	0.6	1
P4SMA530A-AT	P4SMA530CA-AT	530A	530C	450.00	503.50~556.50	1	725.0	0.6	1
P4SMA540A-AT	P4SMA540CA-AT	540A	540C	459.00	513.00~567.00	1	740.0	0.5	1
P4SMA550A-AT	P4SMA550CA-AT	550A	550C	467.00	522.50~577.50	1	760.0	0.5	1

Notes: For bidirectional type having  $V_{RWM}$  of 10V and less, the  $I_R$  limit is double.

**Ratings and Characteristic Curves ( $T_A=25^\circ\text{C}$  unless otherwise noted)**

**Figure 1. Peak Pulse Power Rating Curve**

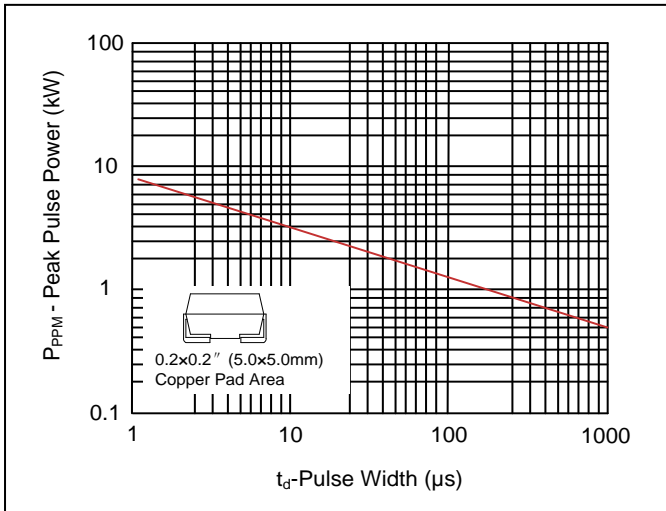

**Figure 2. Pulse Derating Curve**

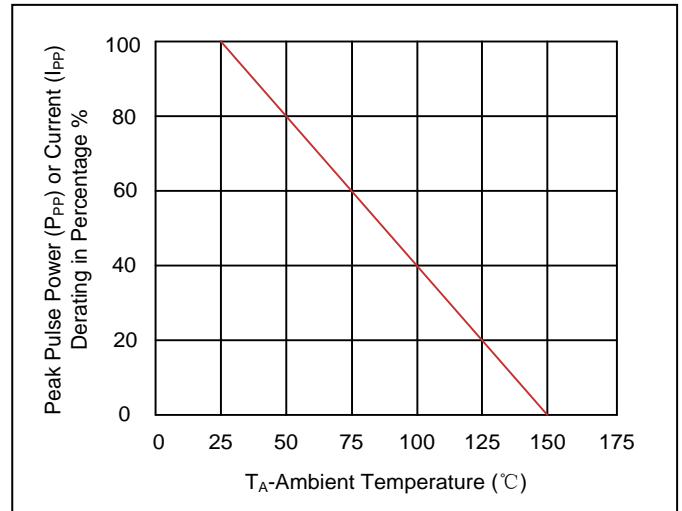

**Figure 3. Pulse Waveform**

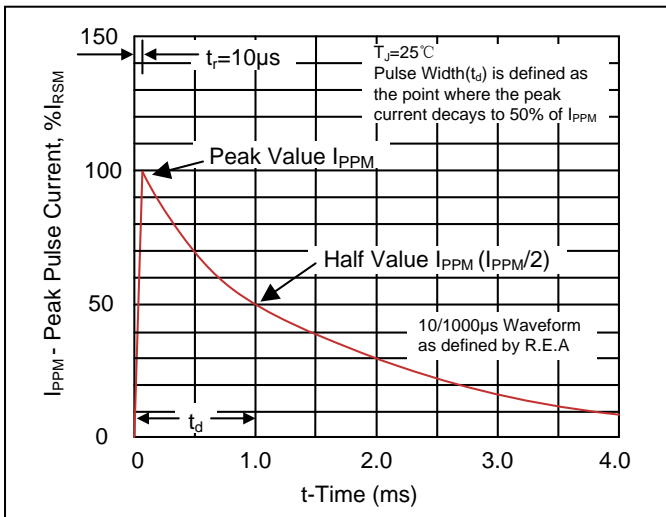

**Figure 4. Typical Junction Capacitance**

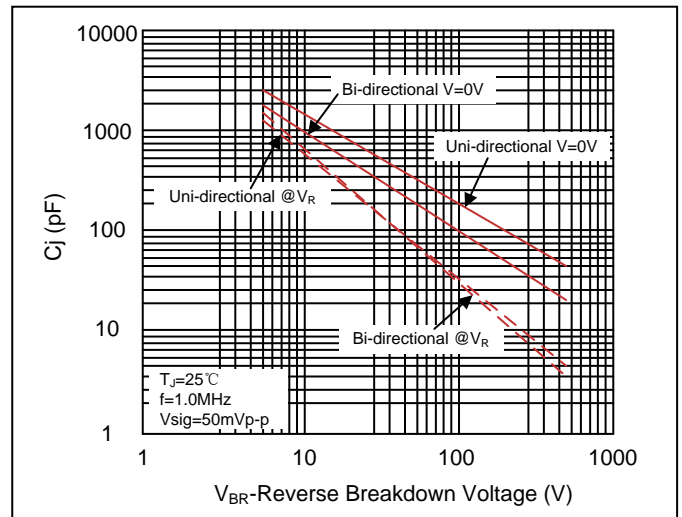

**Figure 5. Steady State Power Dissipation Derating Curve**

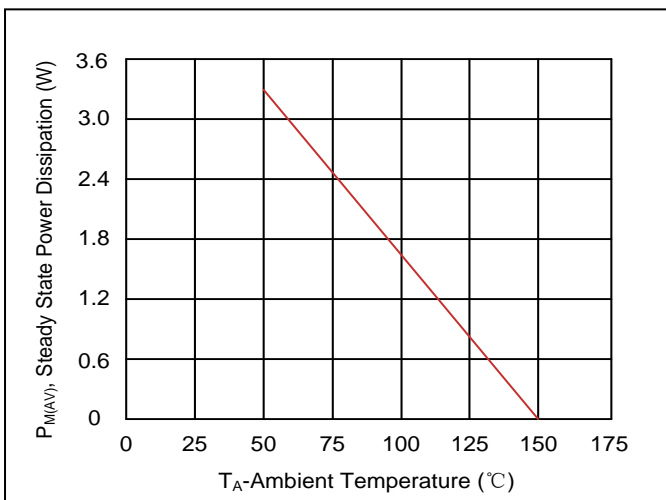

**Figure 6. Maximum Non-Repetitive Forward Surge Current Uni-Directional Only**

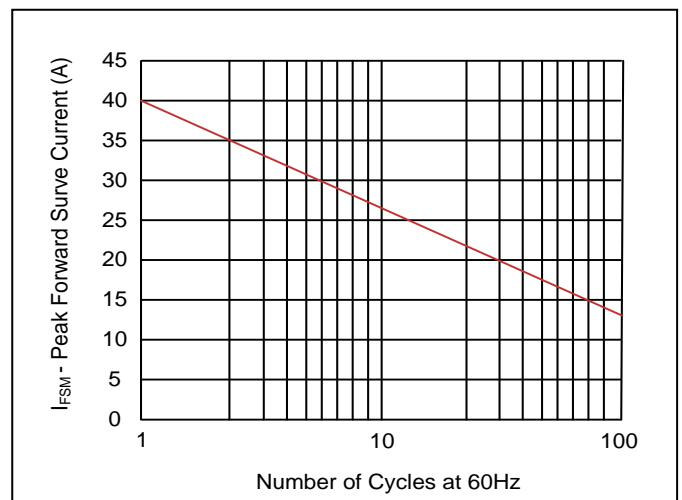

### Recommended Soldering Conditions

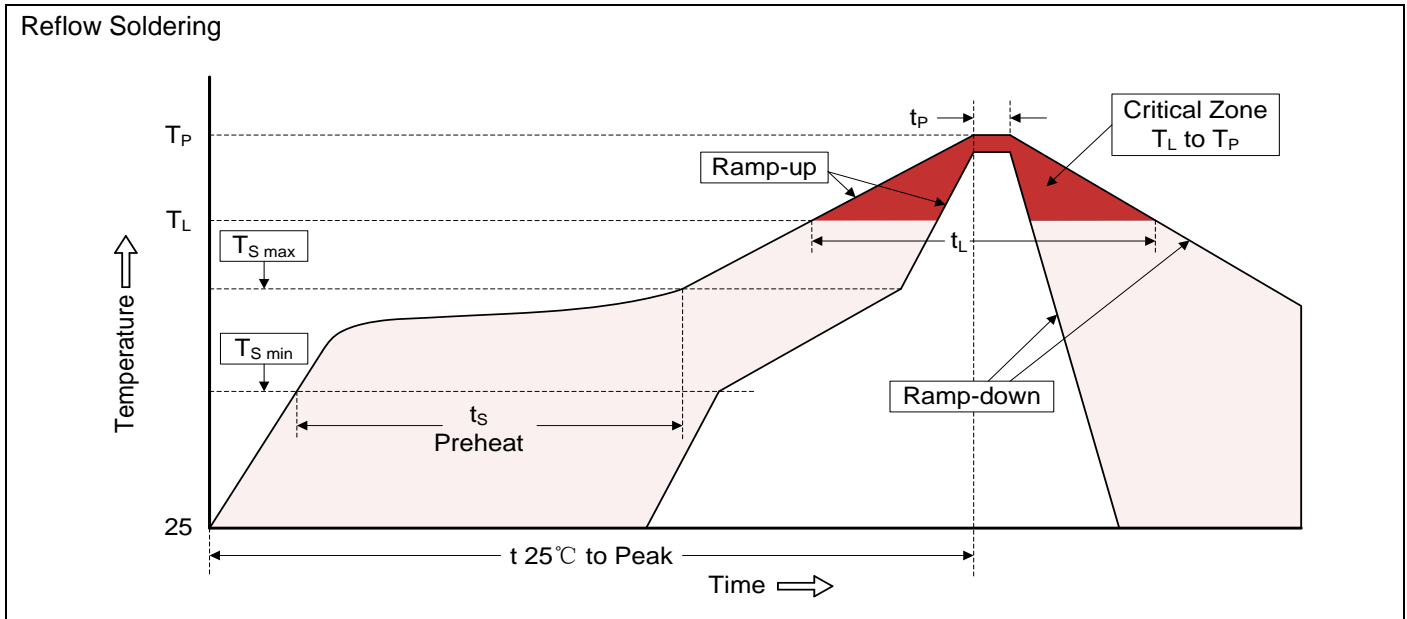

#### Recommended Conditions

Profile Feature	Pb-Free Assembly
Average ramp-up rate ( $T_L$ to $T_P$ )	3°C/second max.
Preheat	
-Temperature Min ( $T_{S\ min}$ )	150°C
-Temperature Max ( $T_{S\ max}$ )	200°C
-Time (min to max) ( $t_s$ )	60-180 seconds
$T_{S\ max}$ to $T_L$	
-Ramp-up Rate	3°C/second max.
Time maintained above:	
-Temperature ( $T_L$ )	217°C
-Time ( $t_L$ )	60-150 seconds
Peak Temperature ( $T_P$ )	260°C
Time within 5°C of actual Peak Temperature ( $t_p$ )	20-40 seconds
Ramp-down Rate	6°C/second max.
Time 25°C to Peak Temperature	8 minutes max.

### Marking Code

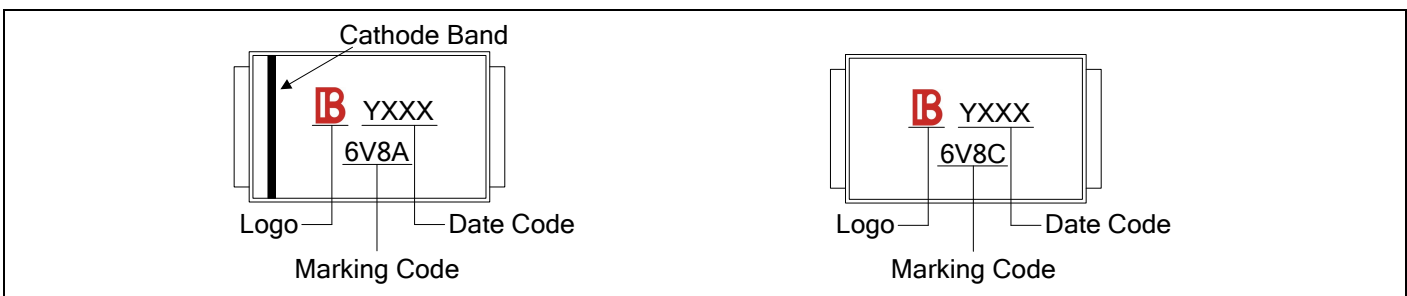

**Part Number Code**

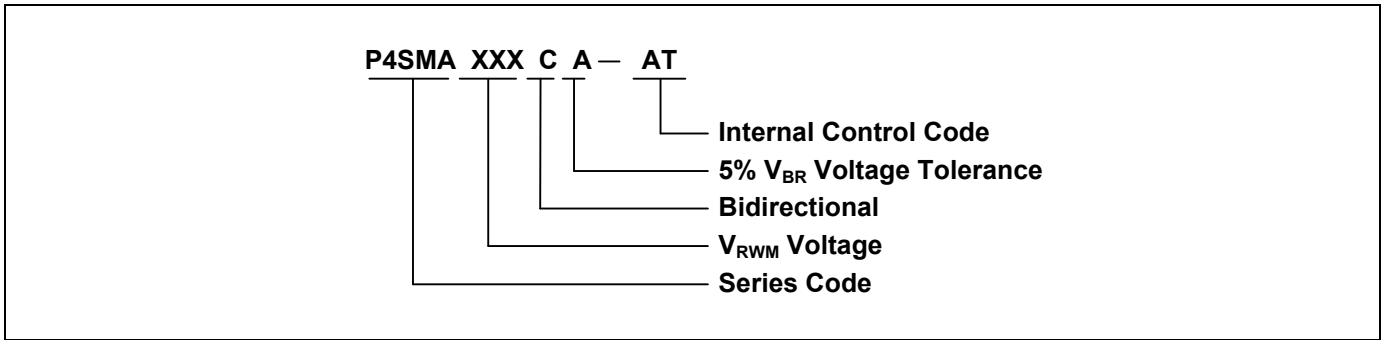

**Ordering Code for Different Package**

7 inch reel package: Add suffix "/TR7" at the end of the part number, such as P4SMA100A-AT/TR7

13 inch reel package: Add suffix "/TR13" at the end of the part number, such as P4SMA150CA-AT/TR13

**Packaging**

Tape		Symbol	Dimension (mm)
		W	12.00±0.20
		P0	4.00±0.10
		P1	4.00±0.10
		P2	2.00±0.10
		D0	Φ1.5±0.10
		D1	Φ1.5±0.10
		E	1.75±0.10
		F	5.50±0.05
		A0	2.79±0.10
		B0	5.33±0.10
		K0	2.55±0.15
		T	0.25±0.05
		D2	Φ178.0±2.0
		D3	Φ50.0Min.
		D4	Φ13.0±0.5
		W1	16.0±2.0
Quantity: 1000PCS			
7" Reel		D5	Φ330.0±2.0
		D6	Φ13.5±0.5
		H	2.5±1.0
		W2	16.0±2.0
		Quantity: 5000PCS	
13" Reel			

单击下面可查看定价，库存，交付和生命周期等信息

[>>Brightking\(君耀电子\)](#)