



# BCT2561

## 2 $\mu$ A I<sub>Q</sub>, 300mA

### Low Dropout Linear Regulators

## BCT2561

### 2 $\mu$ A I<sub>Q</sub>, 300mA Low Dropout Linear Regulators

#### GENERAL DESCRIPTION

The BCT2561 series are ultra-low power, low-dropout CMOS linear voltage regulators. They are the perfect choice for low voltage, low power applications. Quiescent current of only 2 $\mu$ A makes these devices ideal for powering the battery-powered, always-on systems that require very little idle-state power dissipation to a longer service life. The BCT2561 series also offer ultra-low dropout voltage to prolong battery life in portable electronics. Systems requiring a quiet voltage sources.

Other features include a 10nA logic-controlled shutdown mode, current limit and thermal shutdown protection.

The BCT2561 is available in Green SOT23-3 SOT23-5 and UTDFN1x1-4L packages. It operates over an ambient temperature range of -40°C to +85°C.

#### FEATURES

- 2 $\mu$ A Ground Current at no Load
- 300mA Output Current
- $\pm 1\%$  Output Accuracy
- 10nA Logic-Controlled Shutdown
- Wide Operating Input Voltage Range: 1.6V to 5.5V
- Fixed Output Voltage 0.75V, 0.8V, 1.05V, 1.2V, 1.3V, 1.5V, 1.8V, 1.85V, 2.5V, 2.8V, 3.0V, 3.3V
- Thermal-Overload Protection
- Output Current Limit
- Available in Green SOT23-3 , SOT23-5 UTDFN1x1-4L Packages

#### APPLICATIONS

Portable/Battery-Powered Equipment  
Low Power Microcontrollers  
Wireless Communication Equipment  
Audio/Video Equipment  
Hand-Held Instruments

## ORDERING INFORMATION

Order Number	V <sub>OUT</sub> (V)	Package Type	Temperature Range	Marking	QTY/Reel
BCT2561EUK075-TR	0.75	SOT23-5	-40°C to +85°C	NFXX	3000
BCT2561EUK08-TR	0.8	SOT23-5	-40°C to +85°C	N8XX	3000
BCT2561EUK105-TR	1.05	SOT23-5	-40°C to +85°C	NAXX	3000
BCT2561EUK12-TR	1.2	SOT23-5	-40°C to +85°C	N2XX	3000
BCT2561EUK13-TR	1.3	SOT23-5	-40°C to +85°C	N3XX	3000
BCT2561EUK15-TR	1.5	SOT23-5	-40°C to +85°C	N5XX	3000
BCT2561EUK18-TR	1.8	SOT23-5	-40°C to +85°C	N8XX	3000
BCT2561EUK185-TR	1.85	SOT23-5	-40°C to +85°C	NCXX	3000
BCT2561EUK25-TR	2.5	SOT23-5	-40°C to +85°C	N5XX	3000
BCT2561EUK28-TR	2.8	SOT23-5	-40°C to +85°C	N8XX	3000
BCT2561EUK30-TR	3.0	SOT23-5	-40°C to +85°C	N0XX	3000
BCT2561EUK33-TR	3.3	SOT23-5	-40°C to +85°C	N3XX	3000
BCT2561EUR075-TR	0.75	SOT23-3	-40°C to +85°C	NFXX	3000
BCT2561EUR08-TR	0.8	SOT23-3	-40°C to +85°C	N8XX	3000
BCT2561EUR105-TR	1.05	SOT23-3	-40°C to +85°C	NAXX	3000
BCT2561EUR12-TR	1.2	SOT23-3	-40°C to +85°C	N2XX	3000
BCT2561EUR13-TR	1.3	SOT23-3	-40°C to +85°C	N3XX	3000
BCT2561EUR15-TR	1.5	SOT23-3	-40°C to +85°C	N5XX	3000
BCT2561EUR18-TR	1.8	SOT23-3	-40°C to +85°C	N8XX	3000
BCT2561EUR185-TR	1.85	SOT23-3	-40°C to +85°C	NCXX	3000
BCT2561EUR25-TR	2.5	SOT23-3	-40°C to +85°C	N5XX	3000
BCT2561EUR28-TR	2.8	SOT23-3	-40°C to +85°C	N8XX	3000
BCT2561EUR30-TR	3.0	SOT23-3	-40°C to +85°C	N0XX	3000
BCT2561EUR33-TR	3.3	SOT23-3	-40°C to +85°C	N3XX	3000
BCT2561ELS075-TR	0.75	UTDFN1x1-4L	-40°C to +85°C	NFX	10000
BCT2561ELS08-TR	0.8	UTDFN1x1-4L	-40°C to +85°C	N8X	10000
BCT2561ELS105-TR	1.05	UTDFN1x1-4L	-40°C to +85°C	NAX	10000
BCT2561ELS12-TR	1.2	UTDFN1x1-4L	-40°C to +85°C	N2X	10000
BCT2561ELS13-TR	1.3	UTDFN1x1-4L	-40°C to +85°C	N3X	10000
BCT2561ELS15-TR	1.5	UTDFN1x1-4L	-40°C to +85°C	N5X	10000
BCT2561ELS18-TR	1.8	UTDFN1x1-4L	-40°C to +85°C	N8X	10000
BCT2561ELS185-TR	1.85	UTDFN1x1-4L	-40°C to +85°C	NCX	10000
BCT2561ELS25-TR	2.5	UTDFN1x1-4L	-40°C to +85°C	N5X	10000
BCT2561ELS28-TR	2.8	UTDFN1x1-4L	-40°C to +85°C	N8X	10000
BCT2561ELS30-TR	3.0	UTDFN1x1-4L	-40°C to +85°C	N0X	10000
BCT2561ELS33-TR	3.3	UTDFN1x1-4L	-40°C to +85°C	N3X	10000

Note: "N" in Marking is product short code for BCT2561.

"XX" or "X" in Marking will be appeared as the batch code.

#### PIN CONFIGURATION (TOP VIEW)

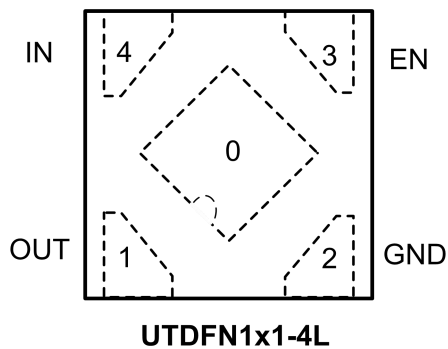
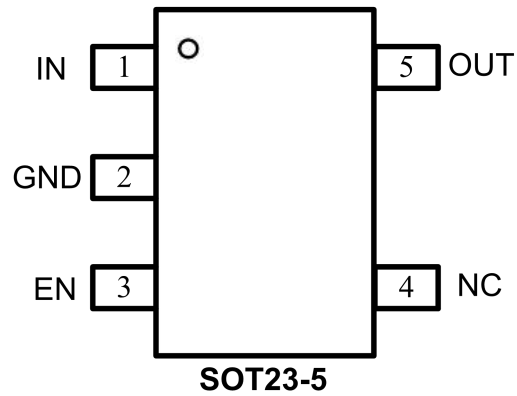
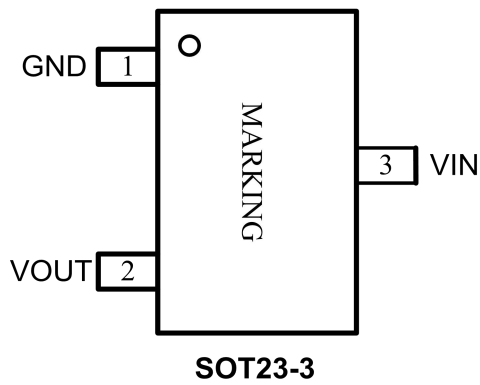

#### PIN DESCRIPTION

PIN			NAME	FUNCTION
SOT23-3	SOT23-5	UTDFN1x1-4L		
1	2	2	GND	Ground.
2	5	1	OUT	Regulator Output.
3	1	4	IN	Input of Supply Voltage.
-	3	3	EN	Enable Control Input. Active high.
-	4	-	NC	No Connection
-	-	0	Exposed Pad	Leave floating or tie to GND.

TYPICAL APPLICATION CIRCUIT

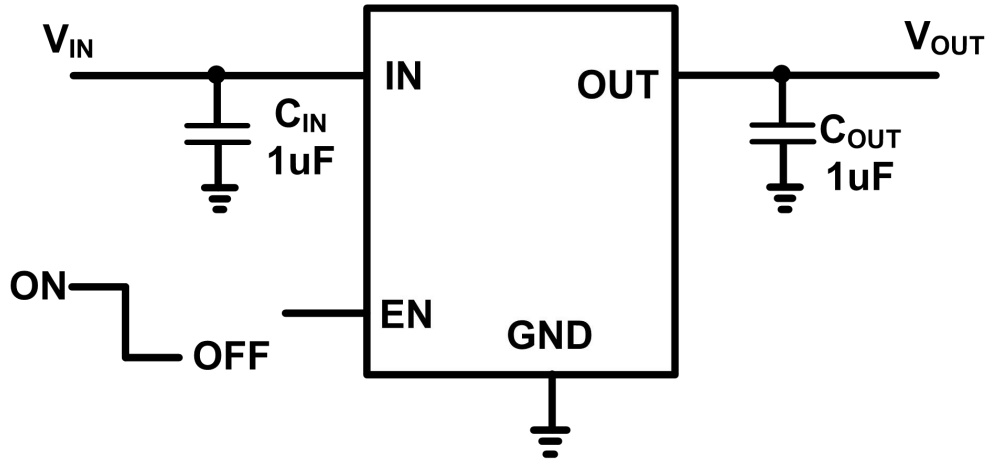



# BCT2561 2uA I<sub>Q</sub>, 300mA

## Low Dropout Linear Regulators

### ABSOLUTE MAXIMUM RATINGS

VIN to GND.....	-0.3V to 6.5V
EN, OUT to GND.....	-0.3V to 6.0V
Output Short-Circuit Duration.....	Infinite
Package Thermal Resistance	
SOT23-3, $\theta_{JA}$ .....	300°C/W
SOT23-5, $\theta_{JA}$ .....	260°C/W
UTDFN1x1-4L, $\theta_{JA}$ .....	280°C/W
Junction Temperature.....	150°C
Operating Temperature Range.....	-40°C to +85°C
Storage Temperature Range.....	-65°C to 150°C
Lead Temperature (Soldering, 10 sec).....	260°C
ESD Susceptibility	
HBM.....	4000V
MM.....	200V

### RECOMMENDED OPERATING CONDITIONS

Operating Voltage Range.....	1.6V to 5.5V
Operating Temperature Range .....	-40°C to +85°C

### OVERSTRESS CAUTION

Stresses beyond those listed under "Absolute Maximum Ratings" may cause permanent damage to the device. These are stress ratings only, and functional operation of the device at these or any other conditions beyond those indicated in the operational sections of the specifications is not implied. Exposure to absolute maximum rating conditions for extended periods may affect device reliability.

### ESD SENSITIVITY CAUTION

This integrated circuit can be damaged by ESD if you don't pay attention to ESD protection. Broadchip recommends that all integrated circuits be handled with appropriate precautions. Failure to observe proper handling and installation procedures can cause damage. ESD damage can range from subtle performance degradation to complete device failure. Precision integrated circuits may be more susceptible to damage because very small parametric changes could cause the device not to meet its published specifications.

### DISCLAIMER

Broadchip reserves the right to make any change in circuit design, specification or other related things if necessary without notice at any time. Please contact Broadchip sales office to get the latest datasheet.



# BCT2561

## 2uA I<sub>Q</sub>, 300mA

### Low Dropout Linear Regulators

#### ELECTRICAL CHARACTERISTICS

(V<sub>IN</sub> = V<sub>OUT(NOMINAL)</sub> + 0.5V, Full = -40°C to +85°C, unless otherwise specified.)

PARAMETER	SYM	CONDITIONS	MIN	TYP	MAX	UNITS
Input Voltage	V <sub>IN</sub>		1.6		5.5	V
Output Voltage Accuracy <sup>(1)</sup>		I <sub>OUT</sub> =0.1mA	-1.0		1.0	%
Maximum Output Current				300		mA
Current Limit	I <sub>LIM</sub>		350	550		mA
Ground Pin Current	I <sub>Q</sub>	No load, EN = V <sub>IN</sub>		2		uA
Dropout Voltage <sup>(2)</sup>	V <sub>DROP</sub>	I <sub>OUT</sub> =300mA	V <sub>OUT</sub> = 0.8V	680		mV
			V <sub>OUT</sub> = 1.2V	420		
			V <sub>OUT</sub> = 1.5V	310		
			V <sub>OUT</sub> = 1.8V	250		
			V <sub>OUT</sub> = 2.5V	200		
			V <sub>OUT</sub> = 2.8V	180		
			V <sub>OUT</sub> = 3.0V	160		
			V <sub>OUT</sub> = 3.3V	150		
Line Regulation	ΔV <sub>LNR</sub>	V <sub>IN</sub> =1.6V or (V <sub>OUT</sub> +0.5V) to 5.5V, I <sub>OUT</sub> =30mA		0.2		%
Load Regulation	ΔV <sub>LDR</sub>	I <sub>OUT</sub> =10mA to 300mA, C <sub>OUT</sub> =1uF		0.2		%
Output Voltage Noise	e <sub>n</sub>	f=10Hz to 100kHz, C <sub>OUT</sub> =1uF, I <sub>OUT</sub> =100mA		48		uV <sub>RMS</sub>
Power Supply Rejection Ratio	PSRR	I <sub>LOAD</sub> =50mA, C <sub>OUT</sub> =1uF, V <sub>IN</sub> =2.2V, V <sub>OUT</sub> =1.2V, f=1KHz		70		dB
<b>SHUTDWON</b>						
EN Input Threshold	V <sub>IH</sub>		1.5			V
	V <sub>IL</sub>				0.4	
EN Input Bias Current	I <sub>IN</sub>	V <sub>IN</sub> =5.0V, EN=5.0V		0.01	1	uA
Shutdown Supply Current	I <sub>Q(SHDN)</sub>	EN=0V		0.01	1	uA
<b>THERMAL PROTECTION</b>						
Thermal Shutdown Temperature	T <sub>SHDN</sub>			150		°C
Thermal Shutdown Hysteresis	ΔT <sub>SHDN</sub>			15		°C

NOTE:

- V<sub>IN</sub> = V<sub>OUT(NOMINAL)</sub> + 0.5V or 1.6V, whichever is greater.
- The dropout voltage is defined as V<sub>IN</sub> - V<sub>OUT</sub>, when V<sub>OUT</sub> is 100mV below the value of V<sub>OUT</sub>.

## Input and Output Capacitor Requirements

The external input and output capacitors of BCT2561 series must be properly selected for stability and performance. Use a 1μF or larger input capacitor and place it close to the IC's VIN and GND pins. Any output capacitor meeting the minimum 1mΩ ESR (Equivalent Series Resistance) and effective capacitance between 1μF and 22μF requirement may be used. Place the output capacitor close to the IC's VOUT and GND pins. Increasing capacitance and decreasing ESR can improve the circuit's PSRR and line transient response.

## Thermal Considerations

Thermal protection limits power dissipation in BCT2561. When the operation junction temperature exceeds 150°C, the OTP circuit starts the thermal shutdown function turn the pass element off. The pass element turns on again after the junction temperature cools by 15°C.

For continue operation, do not exceed absolute maximum operation junction temperature 150°C. The power dissipation definition in device is:

$$P_D = (V_{IN} - V_{OUT}) \times I_{OUT} + V_{IN} \times I_Q$$

The maximum power dissipation depends on the thermal resistance of IC package, PCB layout, the rate of surroundings airflow and temperature difference between junction to ambient. The maximum power dissipation can be calculated by following formula:

$$P_D(\text{MAX}) = (T_J(\text{MAX}) - T_A) / \theta_{JA}$$

Where  $T_J(\text{MAX})$  is the maximum operation junction temperature 150°C,  $T_A$  is the ambient temperature and the  $\theta_{JA}$  is the junction to ambient thermal resistance. For recommended operating conditions specification of BCT2561, where  $T_J(\text{MAX})$  is the maximum junction temperature of the die (150°C) and  $T_A$  is the maximum ambient temperature. The junction to ambient thermal resistance ( $\theta_{JA}$  is layout dependent) for SOT23-5 package is 260°C/W, on standard JEDEC 51-3 thermal test board. The maximum power dissipation at  $T_A = 25^\circ\text{C}$  can be calculated by following formula:

$$P_D(\text{MAX}) = (150^\circ\text{C} - 25^\circ\text{C}) / 260 = 0.48\text{W (SOT23-5)}$$

The maximum power dissipation depends on operating ambient temperature for fixed  $T_J(\text{MAX})$  and thermal resistance  $\theta_{JA}$ . It is also useful to calculate the junction of temperature of the BCT2561 under a set of specific conditions. In this example let the Input voltage  $V_{IN} = 3.3\text{V}$ , the output current  $I_O = 300\text{mA}$  and the case temperature  $T_A = 40^\circ\text{C}$  measured by a thermal couple during operation. The power dissipation for the  $V_O = 2.8\text{V}$  of the BCT2561 can be calculated as:

$$P_D = (3.3\text{V} - 2.8\text{V}) \times 300\text{mA} + 3.3\text{V} \times 2\mu\text{A} \approx 0.15\text{W}$$



# BCT2561

## 2uA I<sub>Q</sub>, 300mA

### Low Dropout Linear Regulators

---

And the junction temperature, T<sub>J</sub>, can be calculated as follows:

$$\begin{aligned}T_J &= T_A + P_D \times \theta_{JA} = 40^\circ\text{C} + 0.15\text{W} \times 260^\circ\text{C/W} \\ &= 40^\circ\text{C} + 39^\circ\text{C} = 79^\circ\text{C} < T_{J(\text{MAX})} = 150^\circ\text{C}\end{aligned}$$

For this operating condition, T<sub>J</sub> is lower than the absolute maximum operating junction temperature 150°C, so it is safe to use the BCT2561 in this configuration.



### TAPE AND REEL INFORMATION

**REEL DIMENSIONS**

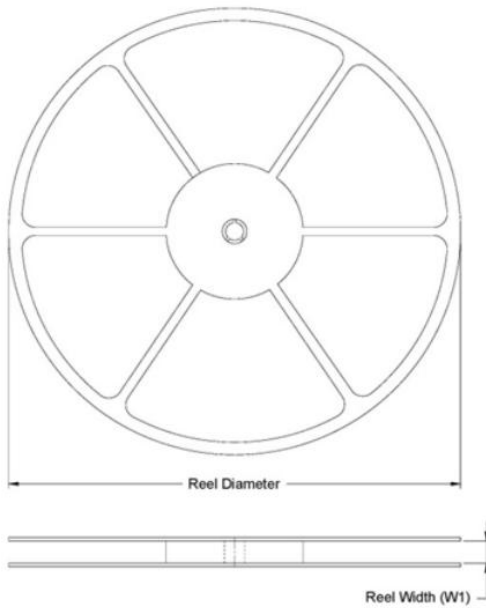

**TAPE DIMENSIONS**

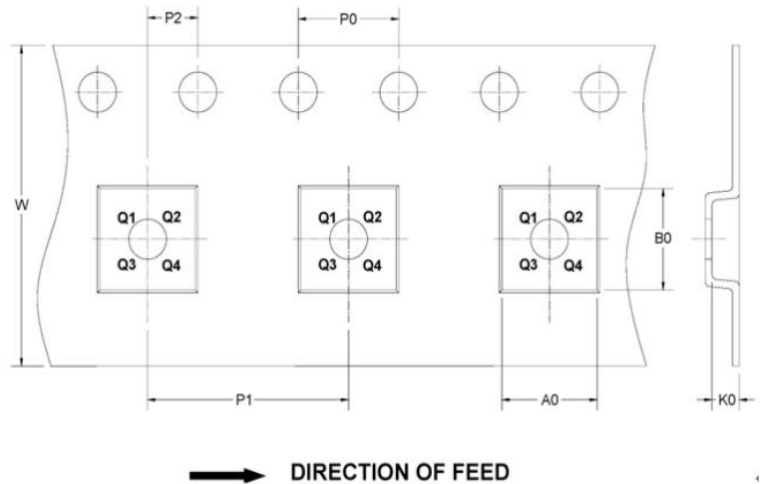

### KEY PARAMETER LIST OF TAPE AND REEL

Device Name	Package Type	Reel Diameter	Unit: mm								Pin 1 Quadrant	Reel Q'ty
			Reel Width W1	A0	B0	K0	P0	P1	P2	W		
BCT2561EUKXX-TR	SOT23-5	7"	9.5	3.23	3.17	1.37	4	4	2	8	Q3	3000
BCT2561EUKXXX-TR												
BCT2561ELSXX-TR	UTDFN1x1-4L	7"	9.5	1.16	1.16	0.5	4	2	2	8	Q1	10000
BCT2561ELSXXX-TR												

**Note:**

XX: 08/12/13/15/18/25/28/30/33

XXX: 075/105/185

### Package Outline Dimensions

SOT23-3

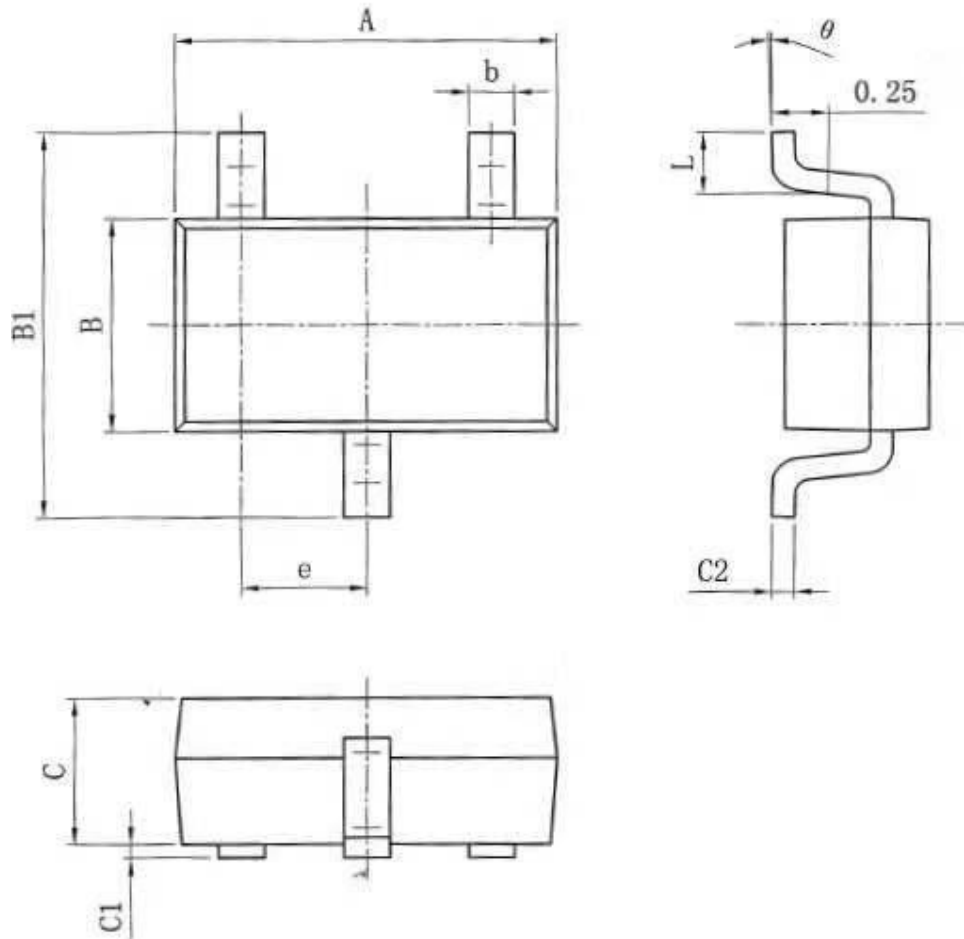

Symbol	Dimensions In Millimeters	
	Min	Max
A	2.82	3.02
e	0.95(BSC)	
b	0.28	0.45
B	1.50	1.70
B1	2.75	3.05
C	1.05	1.15
C1	0.03	0.15
C2	0.12	0.23
L	0.35	0.55
θ	0°	8°

#### SOT23-3 Surface Mount Package

### Package Outline Dimensions

SOT23-5

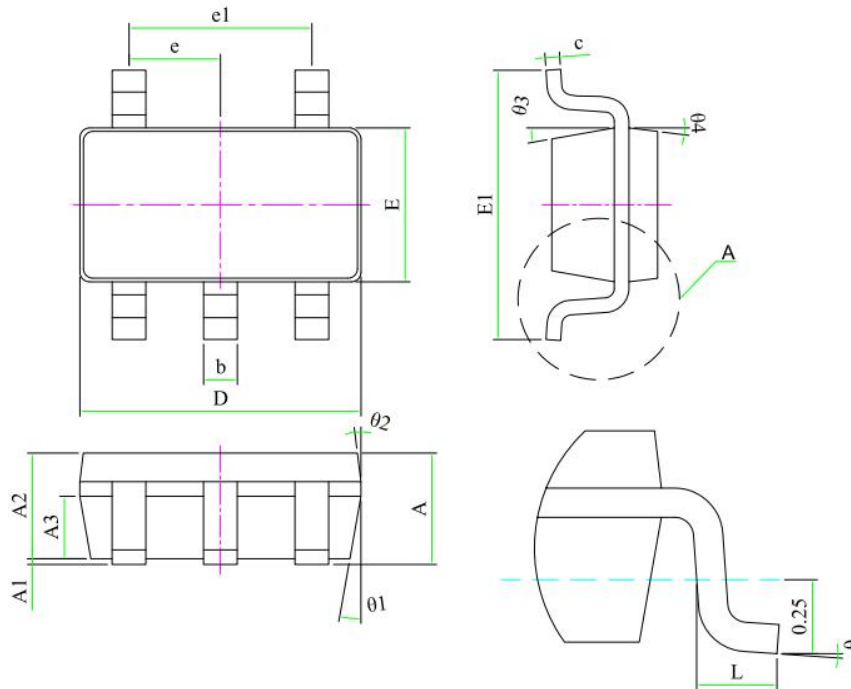

Symbol	Dimensions In Millimeters		
	Min	Nom	Max
A	1.05	1.15	1.25
A1	0.00	0.05	0.10
A2	1.05	1.10	1.15
A3	0.60	0.65	0.70
D	2.82	2.92	3.02
E	1.50	1.60	1.70
E1	2.65	2.80	2.95
L	0.30	0.45	0.60
b	0.28	0.35	0.42
c	0.10	0.15	0.20
e	0.95 (BSC)		
e1	1.80	1.90	2.00
θ	0°	–	8°
θ1	10°	–	14°
θ2	8°	–	12°
θ3	10°	–	14°
θ4	8°	–	12°

**SOT23-5 Surface Mount Package**

### Package Outline Dimensions

UTDFN1x1-4L

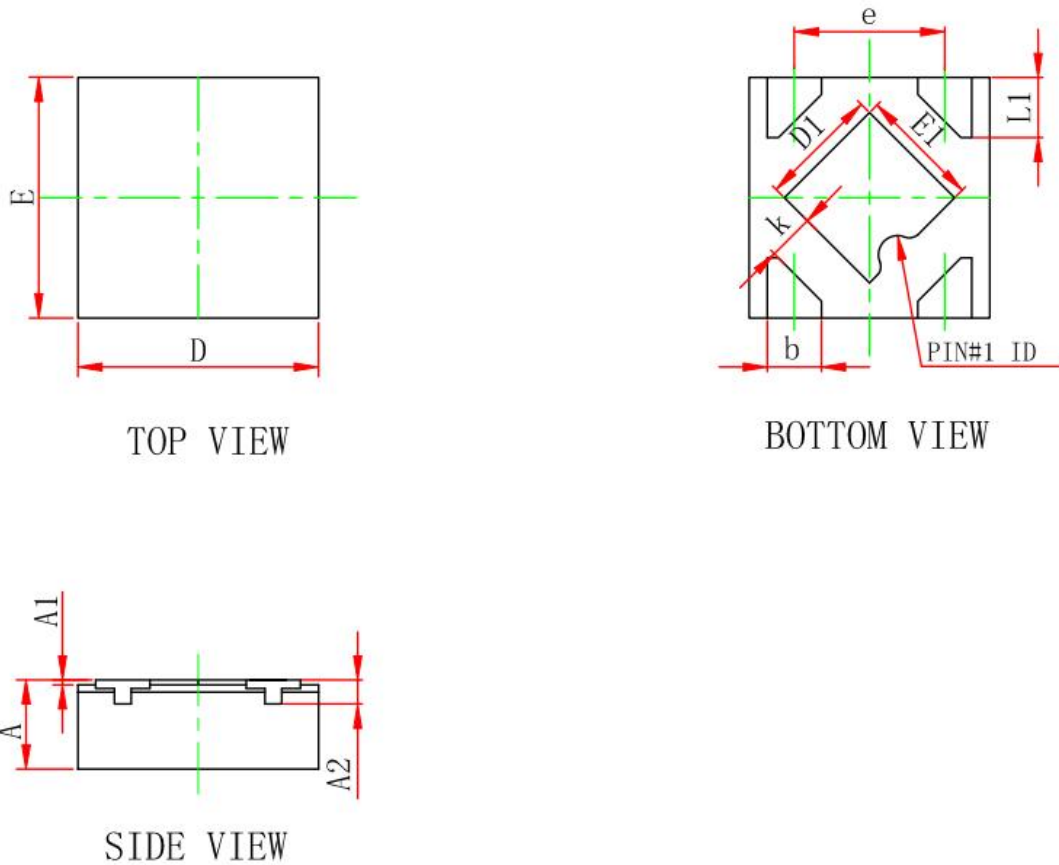

Symbol	Dimensions In Millimeters	
	Min	Max
A	0.335	0.405
A1	0.000	0.050
A2	0.100 REF	
D	0.950	1.050
D1	0.450	0.550
E	0.950	1.050
E1	0.450	0.550
K	0.195 REF	
b	0.175	0.275
e	0.575	0.675
L	0.200	0.300

**UTDFN1x1-4L Surface Mount Package**

## LAND PATTERN DATA

SOT23-3

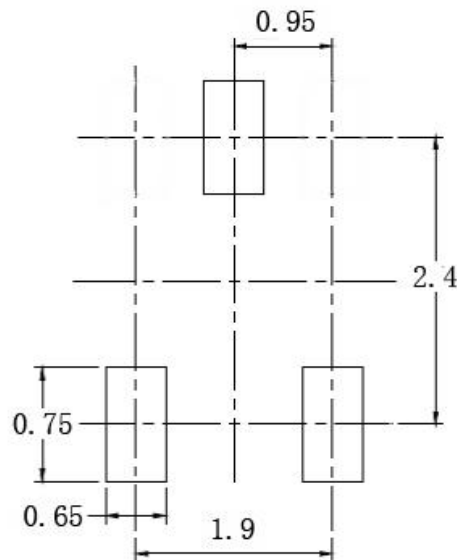

RECOMMENDED PCB LAYOUT PATTERN (Unit: mm)

UTDFN1x1-4L

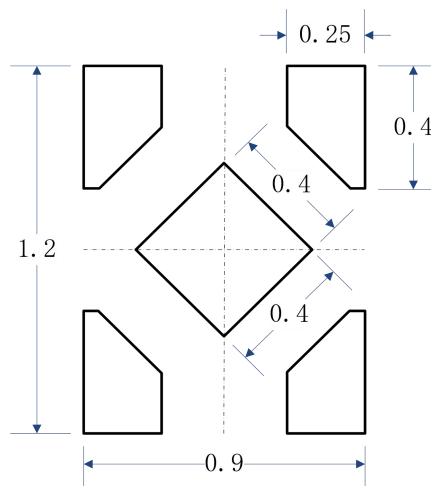

RECOMMENDED PCB LAYOUT PATTERN (Unit: mm)

## SOT23-5

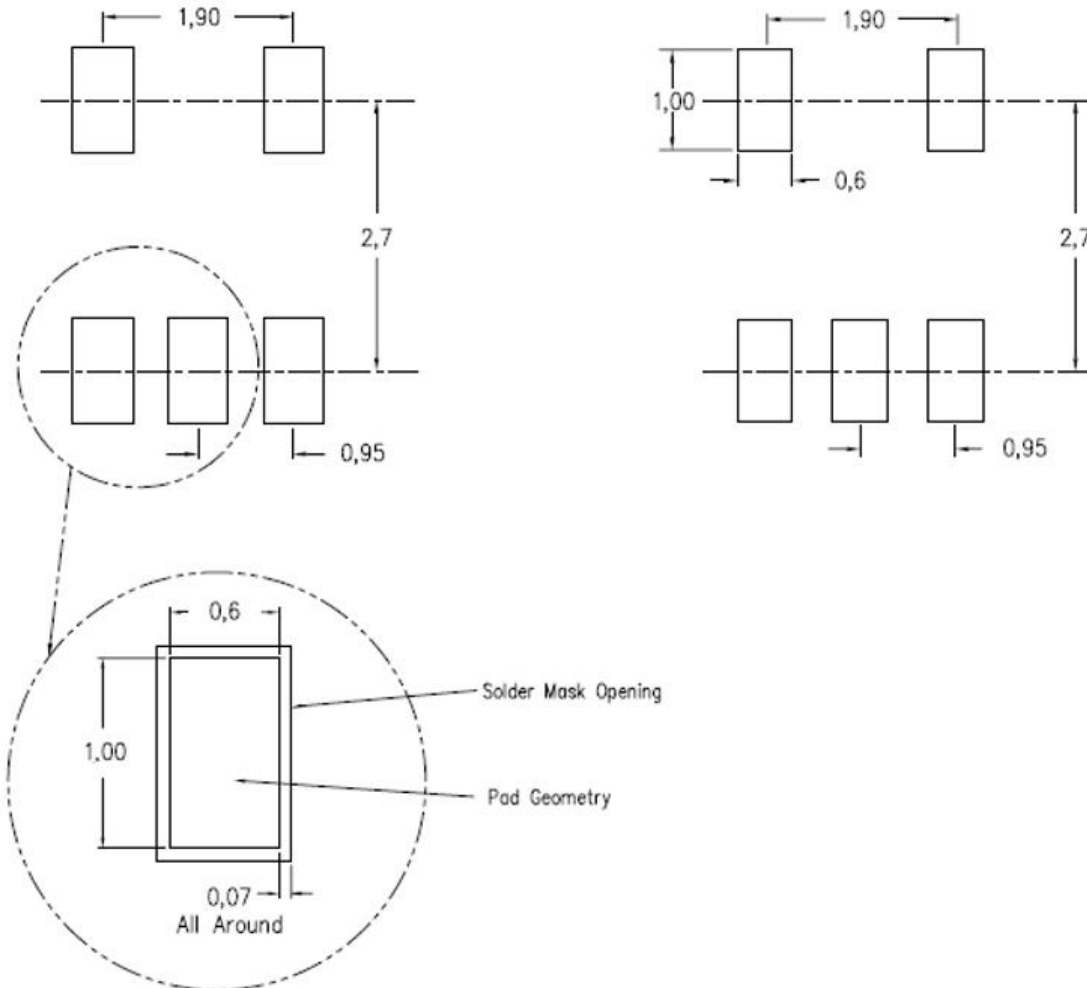

### RECOMMENDED PCB LAYOUT PATTERN (Unit: mm)

单击下面可查看定价，库存，交付和生命周期等信息

[>>Broadchip\(广芯电子\)](#)