



BCT78L05A

0.7uA Low Power, Low Dropout, Linear Regulators

BCT78L05A

0.7uA Low Power, Low Dropout Linear Regulators

GENERAL DESCRIPTION

The BCT78L05A is a low-power, low-noise, low-dropout, CMOS linear voltage regulators operate from a 5.5V to 15.0V input voltage with 0.7uA low power. It is the perfect choice for low voltage, low power applications. A low ground current makes this part attractive for battery operated power systems. The BCT78L05A also offer ultralow dropout voltage to prolong battery life in portable electronics. Output current minimum limit is 300mA.

The BCT78L05A is available in Green SOT23-3 and SOT89-3 packages. It operates over an ambient temperature range of -40°C to +85°C.

FEATURES

- 5.5V-15.0V Wide Input Voltage Range
- ±2% High Accuracy Output Voltage
- 0.7uA Low Power Dissipation
- 300mA Current Rating
- Low Dropout Voltage
- Output Current Limit
- -40°C to 85°C Operating Temperature Range
- Available in Green SOT23-3 and SOT89-3

APPLICATIONS

Modems
Hand-Held Instruments
Portable/Battery-Powered Equipment

ORDERING INFORMATION

Order Number	V _{OUT} (V)	Package Type	Temperature Range	Marking	QTY/Reel
BCT78L05AEJR-TR	5.0	SOT89-3	-40°C to +85°C	78L05A XXXXX	3000
BCT78L05AEUR-TR	5.0	SOT23-3	-40°C to +85°C	P0XX	3000

Note:

"XXXXX" and "XX" in Marking will be appeared as the batch code.

PIN CONFIGURATION

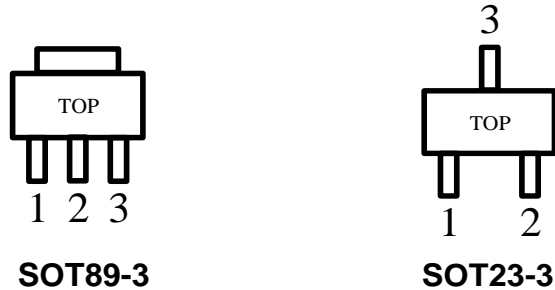

PIN DESCRIPTION

Pin		Name	I/O	DESCRIPTION
SOT89-3	SOT23-3			
1	1	VOUT	O	Output voltage pin for the regulation.
2	3	GND	G	Ground Pin for fixed output.
3	2	VIN	I	Input voltage pin for the regulator.

TYPICAL APPLICATION CIRCUIT

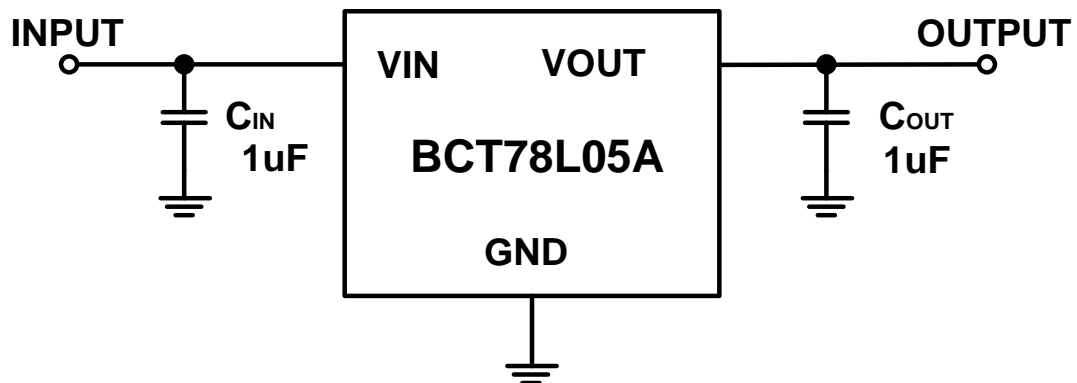

NOTE: If has a large Load Transient in the application, recommend using 4.7uF or more in C_{OUT}.



BCT78L05A

0.7uA Low Power, Low Dropout, Linear Regulators

ABSOLUTE MAXIMUM RATINGS

VIN to GND.....	-0.3V to 16.0V
EN to GND.....	-0.3V to VIN
OUT to GND.....	-0.3V to 5.5V
Output Short-Circuit Duration.....	Infinite
Power Dissipation, P_D @ $T_A=25^\circ\text{C}$	
SOT23-3.....	0.42W
SOT89-3.....	1.25W
Package Thermal Resistance	
SOT23-3, θ_{JA}	300°C/W
SOT89-3, θ_{JA}	100°C/W
Junction Temperature.....	150°C
Operating Temperature Range.....	-40°C to $+85^\circ\text{C}$
Storage Temperature Range.....	-65°C to 150°C
Lead Temperature (Soldering, 10 sec).....	260°C
ESD Susceptibility	
HBM.....	4000V
MM.....	400V

NOTE:

Stresses beyond those listed under "Absolute Maximum Ratings" may cause permanent damage to the device. These are stress ratings only, and functional operation of the device at these or any other conditions beyond those indicated in the operational sections of the specifications is not implied. Exposure to absolute maximum rating conditions for extended periods may affect device reliability.

CAUTION

This integrated circuit can be damaged by ESD if you don't pay attention to ESD protection. Broadchip recommends that all integrated circuits be handled with appropriate precautions. Failure to observe proper handling and installation procedures can cause damage. ESD damage can range from subtle performance degradation to complete device failure. Precision integrated circuits may be more susceptible to damage because very small parametric changes could cause the device not to meet its published specifications.

Broadchip reserves the right to make any change in circuit design, specification or other related things if necessary without notice at any time. Please contact Broadchip sales office to get the latest datasheet.



BCT78L05A

0.7uA Low Power, Low Dropout, Linear Regulators

ELECTRICAL CHARACTERISTICS

($V_{IN}=7V$, $T_A=25^{\circ}C$, unless otherwise specified.)

PARAMETER	SYM	CONDITIONS	MIN	TYP	MAX	UNITS
Input Voltage	V_{IN}		5.5		15.0	V
Output Voltage Accuracy		$I_{OUT}=30mA$	-2.0		2.0	%
Maximum Output Current				300		mA
Current Limit	I_{LIM}			500	800	mA
Short-Circuit Current	I_{SHORT}	$V_{IN}=5.5V-15V$		30		mA
Ground Pin Current	I_Q	No load		0.7	1.5	uA
Dropout Voltage		$I_{OUT}=300mA$		270		mV
Line Regulation	ΔV_{LNR}	$5.5V \leq V_{IN} \leq 15V, I_{OUT}=10mA$		0.022		%/V
Load Regulation	ΔV_{LDR}	$I_{OUT}=1mA$ to 300mA		0.002		%/mA
SHUTDWON						
EN Input Threshold	V_{IH}	$V_{IN}=5.5V$ to 15.0V,	2.5			V
	V_{IL}				0.7	
EN Input Bias Current	$I_{B(SHDN)}$	EN=0V		0.01	0.1	uA

PACKAGE OUTLINE DIMENSIONS

SOT23-3

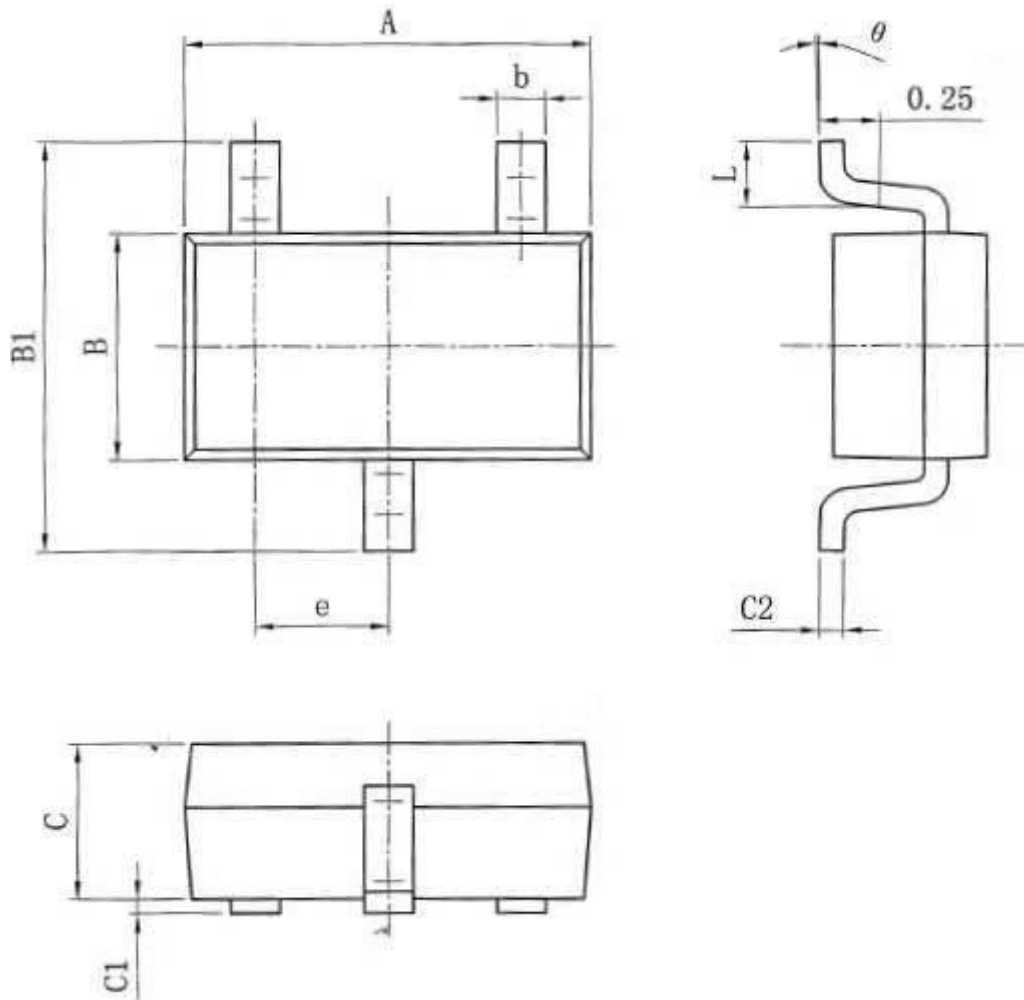

Symbol	Dimensions In Millimeters	
	Min	Max
A	2.82	3.02
e	0.95(BSC)	
b	0.28	0.45
B	1.50	1.70
B1	2.75	3.05
C	1.05	1.15
C1	0.03	0.15
C2	0.12	0.23

L	0.35	0.55
θ	0°	8°

SOT89-3

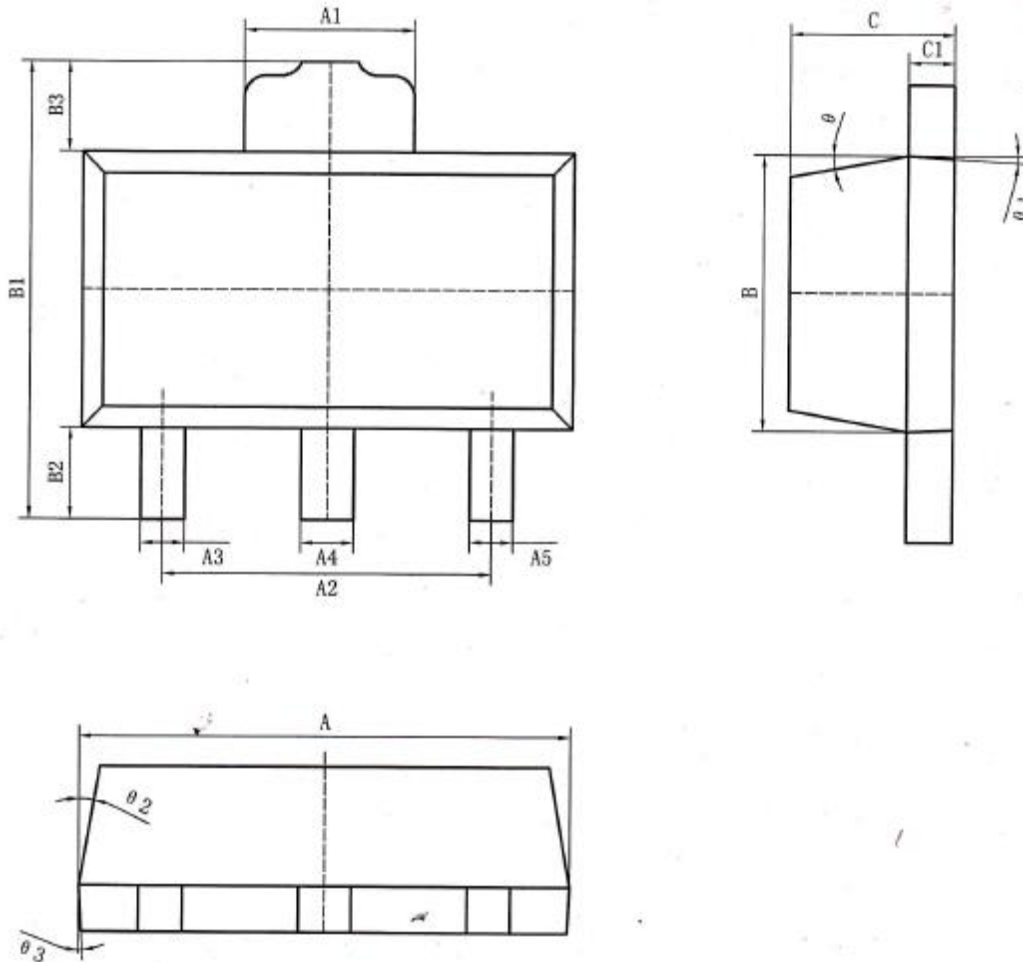

Symbol	Dimensions In Millimeters		Symbol	Dimensions In Millimeters	
	Min	Max		Min	Max
A	4.40	4.60	B2	0.82	0.83
A1	1.65	1.75	B3	0.82	0.83
A2	2.95	3.05	C	1.40	1.60
A3	0.35	0.45	C1	0.35	0.45
A4	0.43	0.53	θ	6° TYP	
A5	0.35	0.45	θ 1	3° TYP	
B	2.40	2.60	θ 2	6° TYP	
B1	4.05	4.25	θ 3	3° TYP	

SOT89-3 Surface Mount Package

PCB Layout Pattern:

SOT23-3 (Unit: mm)

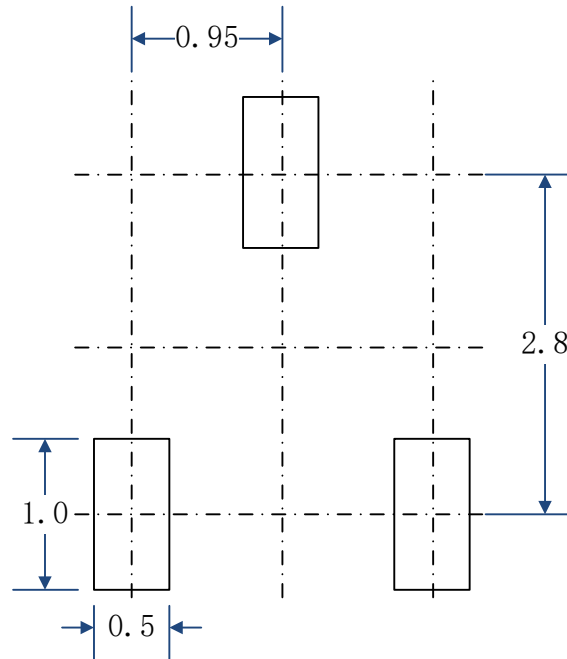

PCB Layout Pattern:

SOT89-3 (Unit: mm)

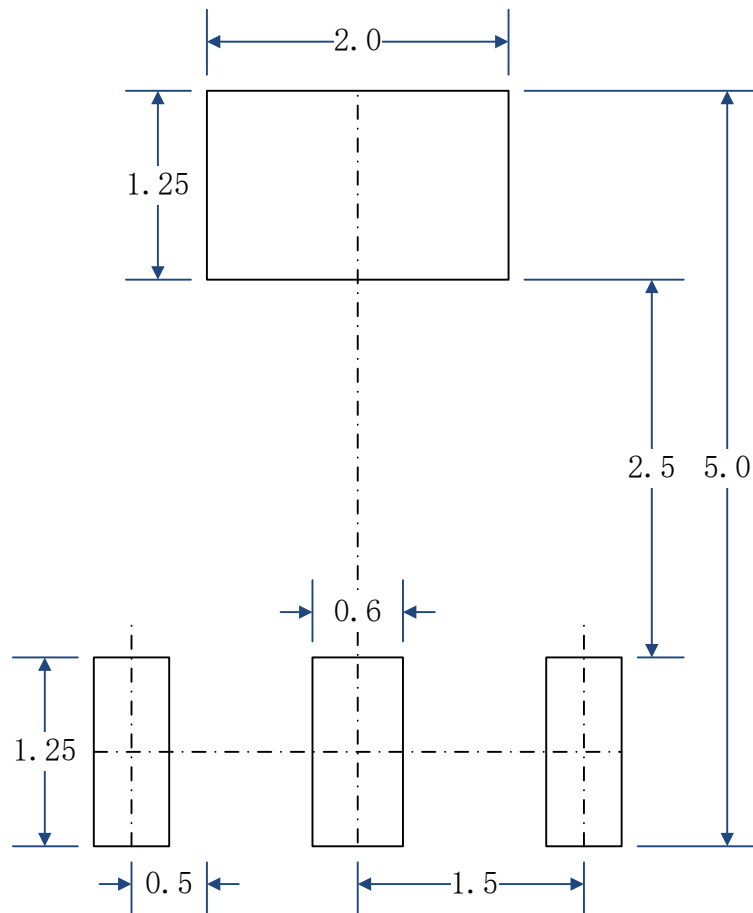

单击下面可查看定价，库存，交付和生命周期等信息

[>>Broadchip\(广芯电子\)](#)