



BCT3220

4 Channel Common-Anode LED Driver With Digital Pulse Brightness Control

BCT3220

4 Channel Common-Anode LED Driver with Digital Pulse Brightness Control

GENERAL DESCRIPTION

The BCT3220 is a high performance white LED driver. The BCT3220 uses an internal resistor to set the bias current for four LEDs, which are matched to 1.5%. The BCT3220's advantages over ballast resistors include much lower bias variation with supply voltage variation, significantly lower dropout voltage, and in some applications, significantly improved efficiency. The BCT3220 requires only a 50mV dropout voltage at a 20mA load on each output to match the LED brightness.

Users can easily configure the LED current from 2.5mA to 20mA by a serial pulse. The Dimming of white LEDs current can be achieved by applying a pulse signal to the EN pin. There are totally 8 steps of current could be set by users. Internal soft start circuitry effectively reduces the in-rush current while both start-up and mode transition.

FEATURES

- ◆ Low 50mV Dropout at 20mA
- ◆ 20mA full scale current
- ◆ 1.5% LED Current Matching (TYP)
- ◆ One Wire interface for 8-Step Brightness Control
- ◆ 2.7V to 5.5V Supply Voltage Range
- ◆ Thermal Shutdown Protection
- ◆ Low Input Noise and EMI
- ◆ RoHS Compliant and 100% Lead (Pb)-Free, DFN2x2-8L Package

APPLICATIONS

- Cell Phones
- PDA's
- Digital Cameras, Camcorders
- Portable Instrumentation
- Battery Powered Equipment

ORDERING INFORMATION

Order Number	Package Type	Temperature Range	Marking	QTY/Reel
BCT3220ELA-TR	DFN2x2-8L	-40°C to +85°C	3220	3000

PIN CONFIGURATION (Top View)

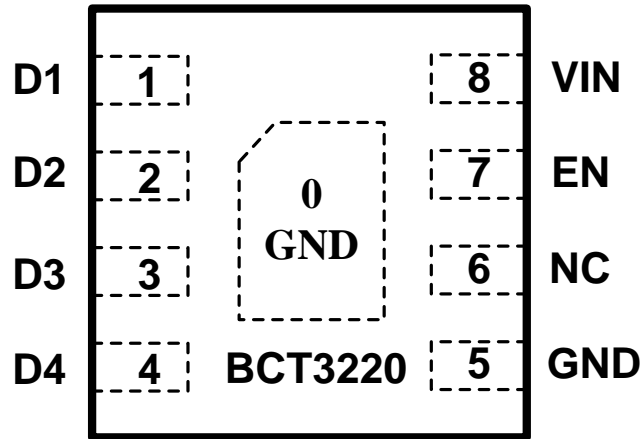

DFN2x2-8L Package

PIN DESCRIPTION

PIN	NAME	FUNCTION
1	D1	LED Pin1, leave it NC if unused.
2	D2	LED Pin2, leave it NC if unused.
3	D3	LED Pin3, leave it NC if unused.
4	D4	LED Pin4, leave it NC if unused.
5	GND	Ground
6	NC	No Connect
7	EN	Chip Enable (Active High), and connects to GPIO pin of MCU.
8	VIN	Input voltage
0	GND	Ground

TYPICAL APPLICATION CIRCUIT

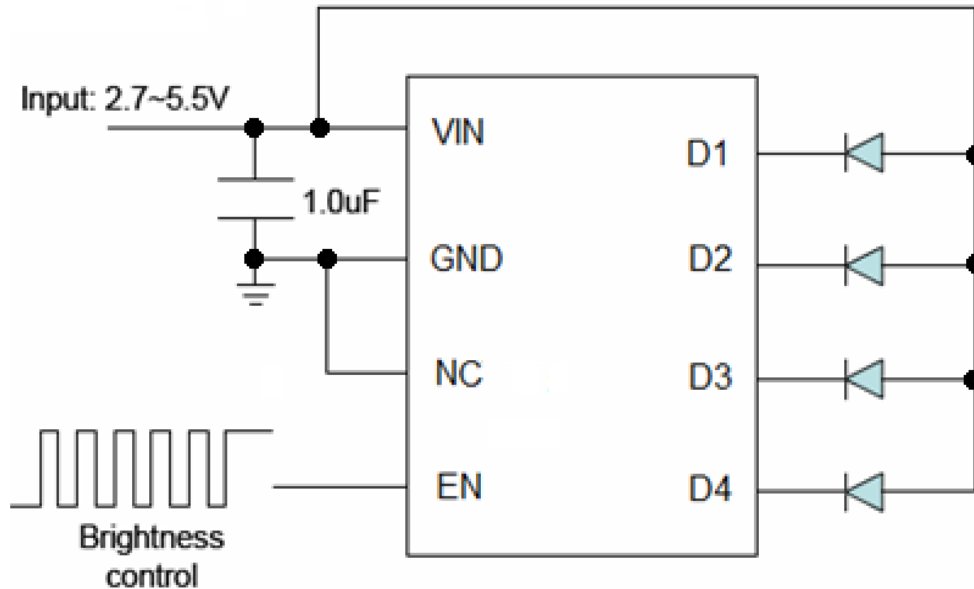

Figure 1: Application Circuit

ABSOLUTE MAXIMUM RATINGS

VIN to GND.....	-0.3V to 6V
All Other Pins to GND	-0.3V to (VCC + 0.3V)
Continuous Current (D1- D4).....	±30mA
Continuous Power Dissipation (TA = +70°C) 8-Pin DFN (derate 10.5mW/°C above +70°C)	0.84W
Operating Temperature Range.....	-40°C to +85°C
Storage Temperature Range.....	-65°C to +150°C
Junction Temperature.....	+150°C
Lead Temperature (soldering, 10s).....	+260°C
ESD HBM (human body model)	±4KV

NOTE:

Stresses beyond those listed under "Absolute Maximum Ratings" may cause permanent damage to the device. These are stress ratings only, and functional operation of the device at these or any other conditions beyond those indicated in the operational sections of the specifications is not implied. Exposure to absolute maximum rating conditions for extended periods may affect device reliability.



BCT3220

4 Channel Common-Anode LED Driver With Digital Pulse Brightness Control

ELECTRICAL CHARACTERISTICS

(VIN = 2.7V to 5.5V, TA = -40°C to +85°C, unless otherwise noted. Typical values are at VIN = 3.3V, TA = +25 °C.)

PARAMETER	SYM	CONDITIONS	MIN	TYP	MAX	UNITS
POWER SUPPLY						
Supply Voltage Range	V _{IN}		2.7		5.5	V
Supply Current	I _{VIN}	V _{IN} = 3.6V, EN=HIGH		150	200	uA
Shut Down Current	I _{SHUT}	EN=LOW			1	uA
Analog Outputs (D1-D4)						
Drop Out Voltage	V _{DROP}	ID ₋ = 20mA, VD ₋ - GND		55	75	mV
Current Accuracy	I _D		18	20	22	mA
Current Matching Between Channels	ΔI _D			1.5	3	%
Logic Inputs (EN)						
Input-Logic High	V _{IH}		1.4			V
Input-Logic Low	V _{IL}				0.4	V
Input Leakage Current	I _{IN}	V _{EN} = 0 or V _{IN}	-1		1	uA
IC junction thermal shutdown threshold	TJ-TH			155		°C

NOTES: Devices are 100% tested at TA = +25°C. Limits across the full temperature range are guaranteed by design and correlation.

Brightness Control by Pulse Dimming

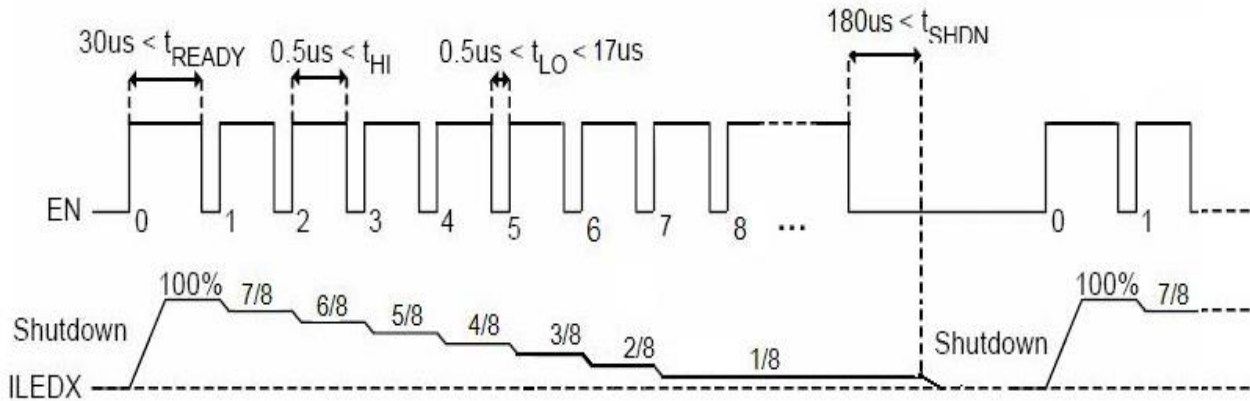
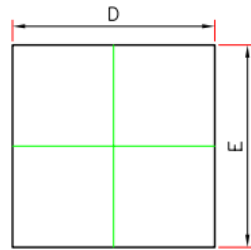

Figure 2: Brightness Control by Pulse Dimming

Number of Pulse Falling Edge	I _{DX} (mA)
0	20
1	17.5
2	15
3	12.5
4	10
5	7.5
6	5
7	2.5

Table 1: Current Setting

PACKAGE OUTLINE DIMENSIONS



TOP VIEW

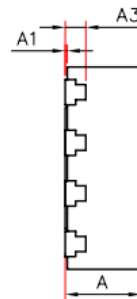

SIDE VIEW

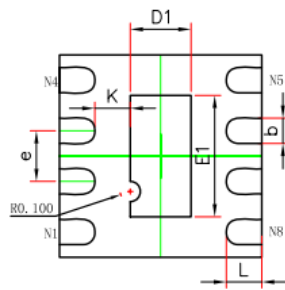

BOTTOM VIEW

Symbol	Dimensions In Millimeters		Dimensions In Inches	
	Min.	Max.	Min.	Max.
A	0.700	0.800	0.028	0.031
A1	0.000	0.050	0.000	0.002
A3	0.203REF.		0.008REF.	
D	1.900	2.100	0.075	0.083
E	1.900	2.100	0.075	0.083
D1	0.500	0.700	0.020	0.028
E1	1.100	1.300	0.043	0.051
k	0.350REF.		0.014REF.	
b	0.200	0.300	0.008	0.012
e	0.500BSC.		0.020BSC.	
L	0.274	0.426	0.011	0.017

DFN2x2-8L

单击下面可查看定价，库存，交付和生命周期等信息

[>>Broadchip\(广芯电子\)](#)