



BCT4321N

USB2.0 Hi-Speed and Audio Switches With Negative Signal Capability

BCT4321N

USB2.0 Hi-Speed and Audio Switches with Negative Signal Capability

GENERAL DESCRIPTION

The BCT4321N is a double-pole double-throw (DPDT) analog switch with multiplexes USB2.0 and negative signal audio analog signals. One Channel has wide bandwidth and low bit-to-bit skew allow it to pass high-speed differential signals with good signal integrity. Another channel has ultra-Low on resistance (2.5Ω). Each switch is bidirectional and offers little or no attenuation of the signals at the outputs. Industry-leading advantages include a propagation delay of less than 250ps, resulting from its low channel resistance and low I/O capacitance. Their high channel-to-channel crosstalk rejection results in minimal noise interference.

The BCT4321N is available in Green QFN1.4X1.8-10 packages. It operates over an ambient temperature range of -40°C to +85°C.

FEATURES

- V_{CC} Operating Range: 2.7V to 5.0V
- -3dB Bandwidth: 720MHz(USB Mode)
- Off Isolation: 66dB @1MHz
- Crosstalk Rejection: 86dB @1MHz
- Low ON Resistance:
 - 2.5-ohm at V_{CC} = 3.6 V (Audio Mode)
 - 8.5-ohm at V_{CC} = 3.6 V (USB Mode)
- Analog Signal Range:
 - V_{CC}-6.5V to V_{CC}-2 (Audio Mode)
 - 0V to V_{CC} (USB Mode)
- Audio Channel Shunt Resistors for Pop & Click Noise Reduction
- Power-off Protection on Common D+/R, D-/L Ports

APPLICATIONS

- Cell Phones
- Hi-Fi Audio Switching
- USB 2.0 High Speed Data Switching
- USB 3.x Type C Switching

ORDERING INFORMATION

Order Number	Package Type	Temperature Range	Marking	QTY/Reel
BCT4321NETB-TR	QFN1.4X1.8-10	-40°C to +85°C	AQX	3000

PIN CONFIGURATION

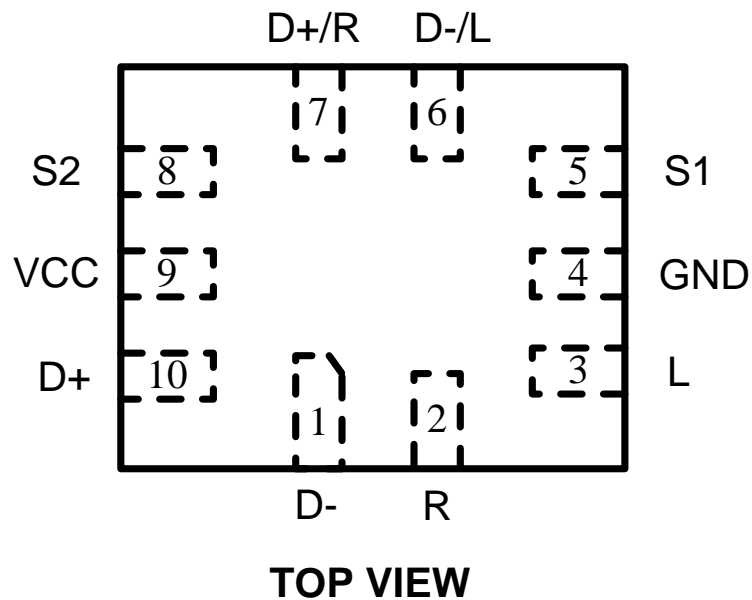

PIN DESCRIPTION

PIN	NAME	FUNCTION
1	D-	USB data bus DATA-
2	R	Audio right
3	L	Audio left
4	GND	Power Ground
5	S1	Logic Control Input 1
6	D-/L	USB and audio common connector ports.
7	D+/R	USB and audio common connector ports.
8	S2	Logic Control Input 2
9	VCC	Power Supply
10	D+	USB data bus DATA+

Truth Table

S1	S2	Audio Mode	USB Mode	Remarks
0	0	ON	OFF	Audio On
0	1	OFF	ON	USB Communication
1	0	OFF	OFF	Low Power Mode
1	1	ON	OFF	Audio On

LOGIC DIAGRAM

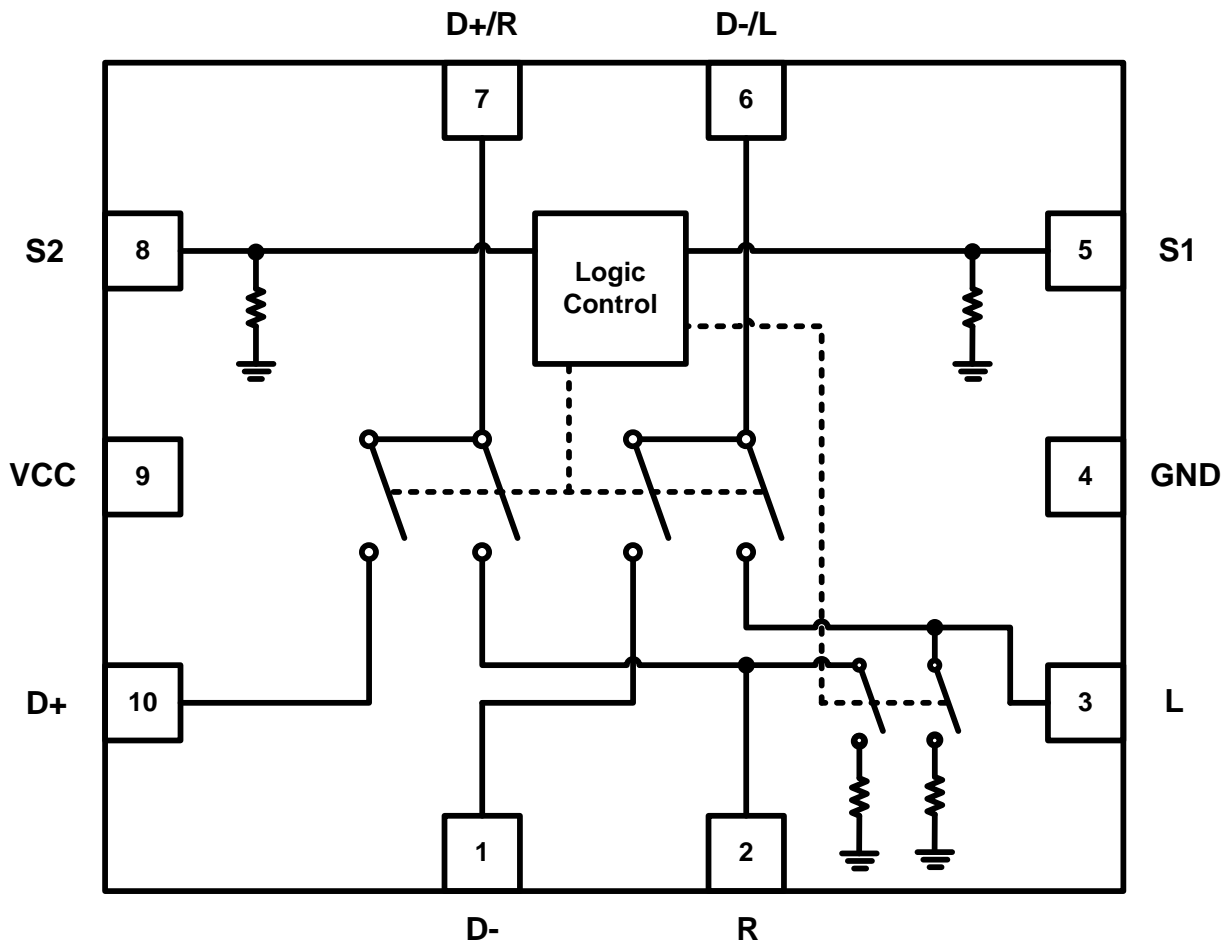

TYPICAL APPLICATION CIRCUIT

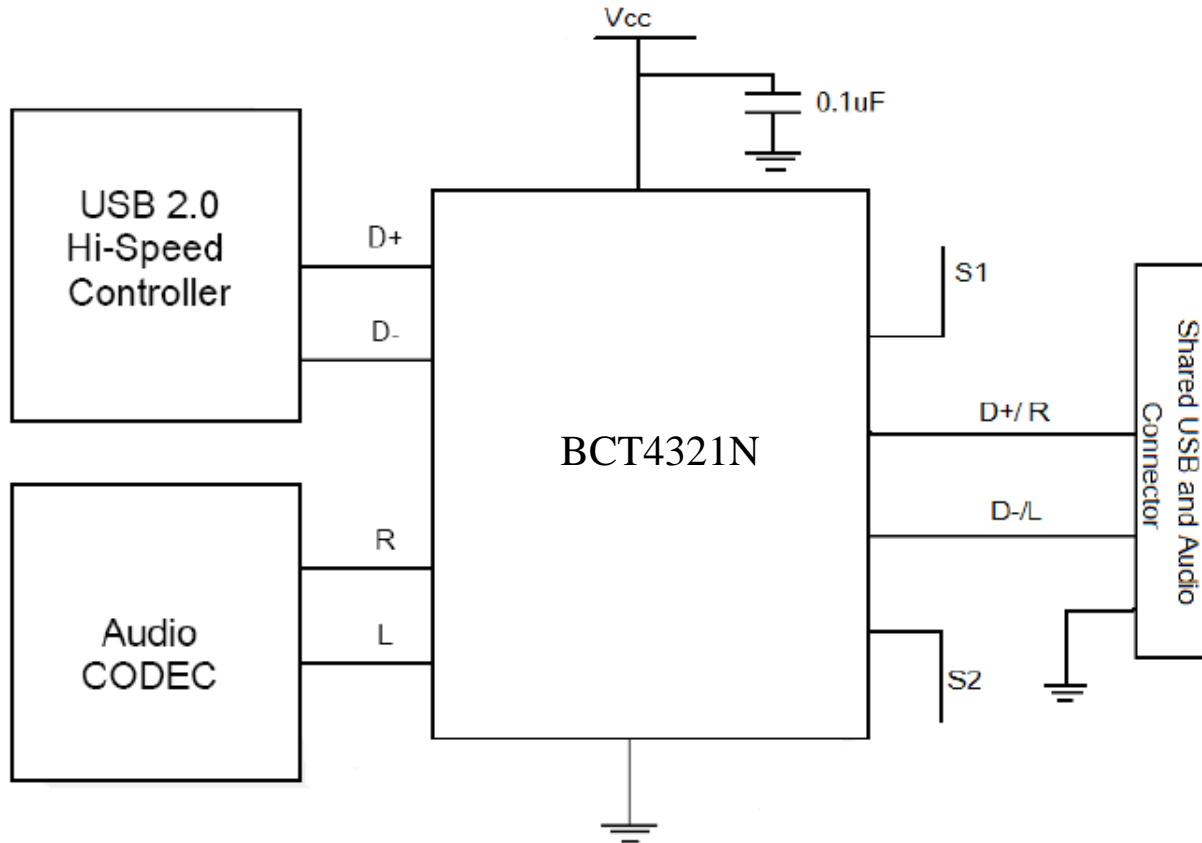



BCT4321N

USB2.0 Hi-Speed and Audio Switches With Negative Signal Capability

ABSOLUTE MAXIMUM RATINGS

VCC, S1, S2 to GND.....	-0.65V to +5.25V
All Other Pins to GND.....	$V_{CC}-6.5V$ to $(V_{CC} + 0.3V)$
Continuous Current (D+/-,R/L, D+/R,D-/L).....	$\pm 400mA$
Peak Current (D+/-,R/L, D+/R,D-/L)(pulsed at 1ms, 10% duty cycle).....	$\pm 500mA$
Continuous Power Dissipation (TA = +70°C)	
10-Pin TQFN (derate 15.6mW/°C above +70°C)	1.25W
Operating Temperature Range	-40°C to +85°C
Storage Temperature Range.....	-65°C to +150°C
Junction Temperature.....	+150°C
Lead Temperature (soldering, 10s).....	+300°C

Stresses beyond those listed under “Absolute Maximum Ratings” may cause permanent damage to the device. These are stress ratings only, and functional operation of the device at these or any other conditions beyond those indicated in the operational sections of the specifications is not implied. Exposure to absolute maximum rating conditions for extended periods may affect device reliability.

CAUTION

This integrated circuit can be damaged by ESD if you don't pay attention to ESD protection. Broadchip recommends that all integrated circuits be handled with appropriate precautions. Failure to observe proper handling and installation procedures can cause damage. ESD damage can range from subtle performance degradation to complete device failure. Precision integrated circuits may be more susceptible to damage because very small parametric changes could cause the device not to meet its published specifications.

Broadchip reserves the right to make any change in circuit design, specification or other related things if necessary without notice at any time. Please contact Broadchip sales office to get the latest datasheet.



BCT4321N

USB2.0 Hi-Speed and Audio Switches With Negative Signal Capability

ELECTRICAL CHARACTERISTICS

(VCC = 2.7V to 5.0V, TA = -40°C to +85°C, unless otherwise noted. Typical values are at VCC = 3.6V, TA = +25°C.) (Note 1)

PARAMETER	SYM	CONDITIONS	MIN	TYP	MAX	UNITS
POWER SUPPLY						
Supply Voltage Range	V _{CC}		2.7		5.0	V
Supply Current	I _{CC}	V _{CC} =3.6V, S1,S2=0 or V _{CC} , D+/-,R/L,D-/L,D+/R = floating		0.02	1	uA
USB SWITCH						
Analog Signal Range		USB mode, D+, D-, D+/R, D-/L	0		V _{CC}	V
On-Resistance	R _{ON}	I _{SW} = 8mA, V _{D+} , V _{D-} = 0 to V _{CC}		8.5		Ω
On-Resistance Match	ΔR _{ON}	I _{SW} = 8mA, V _{D+} , V _{D-} = 0 to V _{CC} (Note2)		0.5		Ω
On-Resistance Flatness	R _{FLAT}	I _{SW} = 8mA, V _{D+} , V _{D-} = 0 to V _{CC} (Note 3)		2.5		Ω
D+,D- Off-Leakage Current	I _{OFF}	Audio mode ,V _{D+/R} , V _{D-/L} = floating			100	nA
D+,D-, On-Leakage Current	I _{ON}	USB mode, V _{D+/R} , V _{D-/L} = floating			100	nA
AUDIO SWITCH						
Analog Signal Range		Audio mode ,R, L, D+/R, D-/L	V _{CC} -6.5		V _{CC} -2	V
On-Resistance	R _{ON}	I _{SW} =60mA, V _R , V _L = -1V to 1V		2.5		Ω
On-Resistance Match	ΔR _{ON}	I _{SW} =60mA, V _R , V _L = -1V to 1V (Note 2)		0.2		Ω
On-Resistance Flatness	R _{FLAT}	I _{SW} =60mA, V _R , V _L = -1V to 1V (Note 3)		0.4		Ω
Shunt Resistance	R _{SH}	USB mode, I _L , I _R = 5mA		4		KΩ
DIGITAL INPUTS						
Input-Logic High	V _{IH}	V _{CC} =2.7 – 5.0V	1.7			V
Input-Logic Low	V _{IL}	V _{CC} =2.7 – 5.0V			0.5	V
Input Leakage Current High	I _{IH}	V _{CC} = V _{IN} = 3.6		2.5	10	uA
Input Leakage Current Low	I _{IL}	V _{CC} =3.6V, V _{IN} = 0V	-1		1	uA



BCT4321N

USB2.0 Hi-Speed and Audio Switches With Negative Signal Capability

ELECTRICAL CHARACTERISTICS

(VCC = 2.7V to 5.0V, TA = -40°C to +85°C, unless otherwise noted. Typical values are at VCC = 3.6V, TA = +25°C.) (Note 1)

PARAMETER	SYM	CONDITIONS	MIN	TYP	MAX	UNITS
DYNAMIC CHARACTERISTICS						
Turn-On Time	T _{ON}	V _R or V _L or V _{D+} or V _{D-} = 1.5V, RL = 50Ω, CL = 35pF, (Figure 2)		20	50	nS
Turn-Off Time	T _{OFF}	V _R or V _L or V _{D+} or V _{D-} = 1.5V, RL = 50Ω, CL = 35pF, (Figure 2)		15	50	nS
Break-Before-Make Time	T _{BBM}	V _R , V _{D+} , V _L , V _{D-} = 1.5V RL = 50Ω, CL = 35pF, (Figure 1)	2	15		nS
On-Channel Bandwidth -3dB	BW	USB mode, RL = 50Ω, (Figure 4)		720		MHz
Off-Isolation	Q _{IRR}	D+/R, D-/L = 0.5 V _{PP} , RL = 50Ω, f = 1MHz, CL = 5pF, Figure 5 (Note 4)		-66		dB
Crosstalk	X _{TALK}	D+/R, D-/L = 0.5 V _{PP} , RL = 50Ω, f = 1MHz, CL = 5pF,		-86		dB
Total Harmonic Distortion Plus Noise (Audio)	THD+N	Audio mode, f = 20Hz to 20kHz; V _R or V _L = 0.5 V _{PP} , RL = 32Ω,		0.02		%
D+,D- Off-Capacitance	C _{OFF}	Audio mode, f = 1MHz, (Figure 3)		5		pF
D+,D- On-Capacitance	C _{ON}	USB mode, f = 1MHz, V _{D+/R} or V _{D-/L} = floating, (Figure 3)		7		pF

NOTES:

Note 1: Devices are 100% tested at TA = +25°C. Limits across the full temperature range are guaranteed by design and correlation.

Note 2: ΔRON = RON(MAX) - RON(MIN).

Note 3: Flatness is defined as the difference between the maximum and minimum value of on-resistance, as measured over the specified analog signal ranges.

Note 4: Between any two switches.

Test Diagram

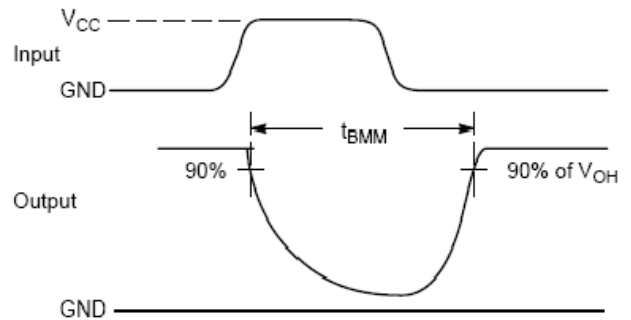
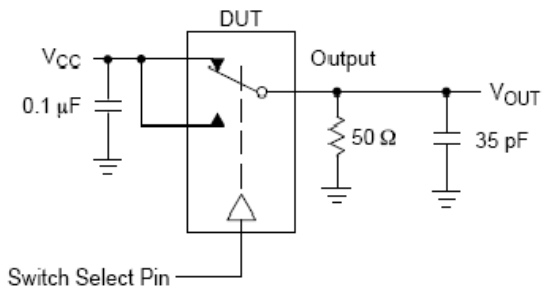

Figure 1. tBBM (Time Break-Before-Make)

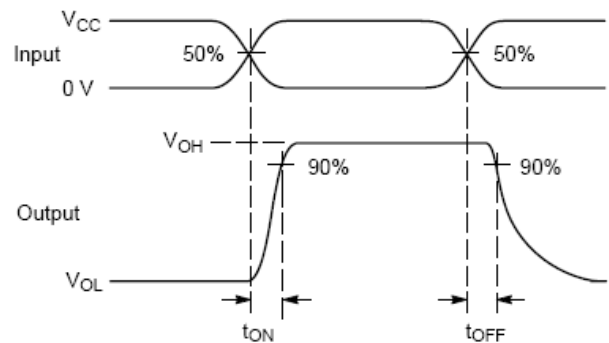
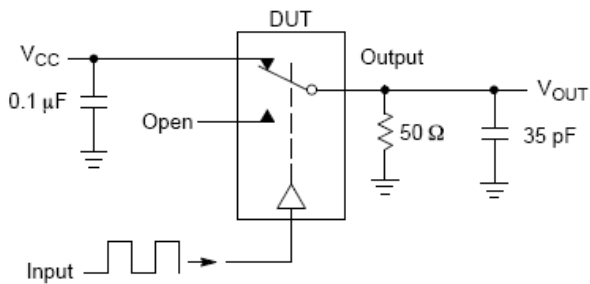

Figure 2. tON/OFF

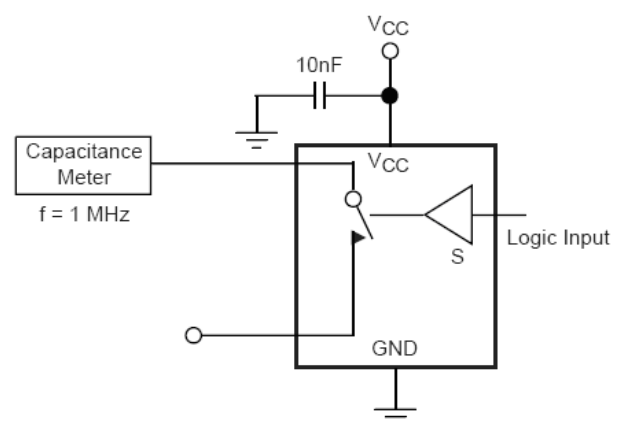
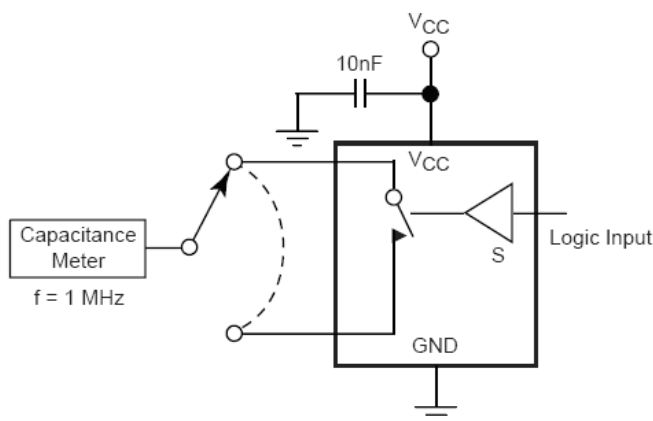

Figure 3. Channel ON/OFF Capacitance

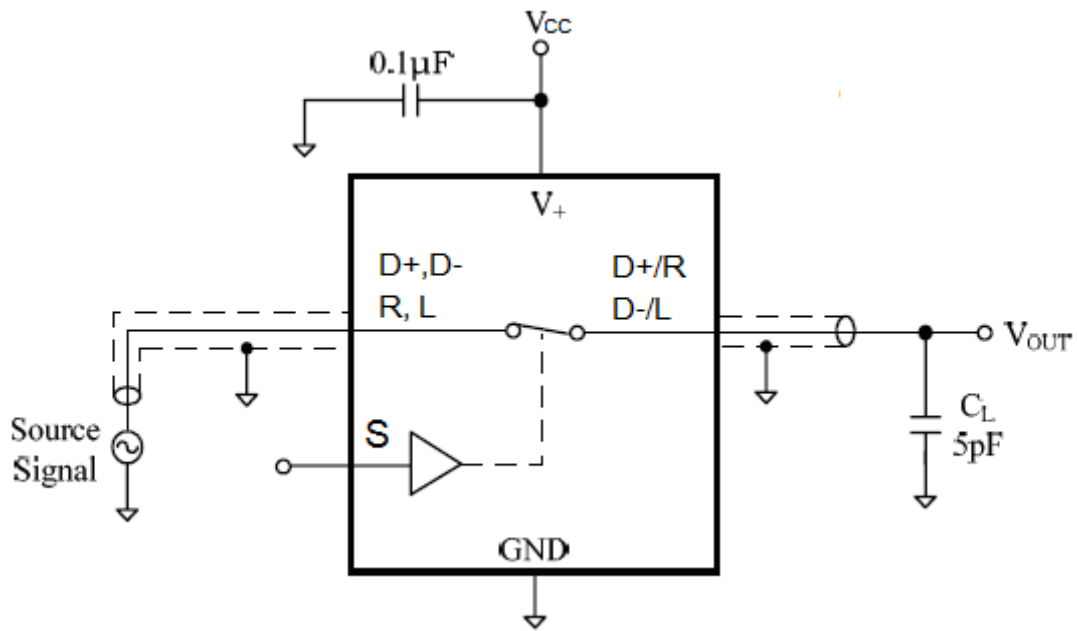
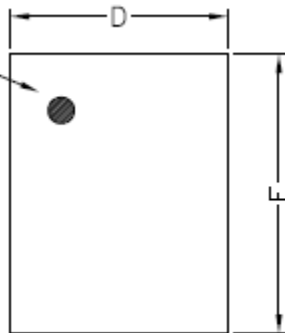

Figure 4. Bandwidth -3dB

PACKAGE OUTLINE DIMENSIONS

QFN1.4x1.8-10

PIN 1 DOT
BY MARKING



TOP VIEW

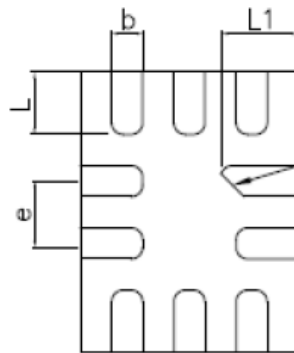

BOTTOM VIEW

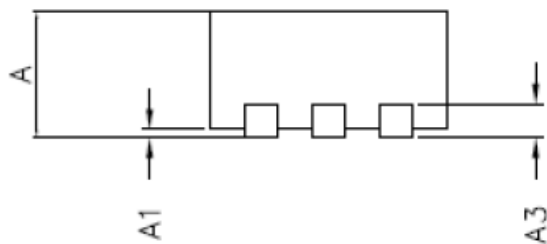

COMMON DIMENSIONS(mm)			
PKG	UT:ULTRA THIN		
REF	MIN	NOM	MAX
A	0.50	0.55	0.60
A1	0.00	--	0.05
A3	0.15 REF		
D	1.35	1.40	1.45
E	1.75	1.80	1.85
b	0.15	0.20	0.25
L	0.30	0.40	0.50
L1	0.40	0.50	0.60
e	0.40 BSC		

PCB Layout Pattern: QFN1.4x1.8-10

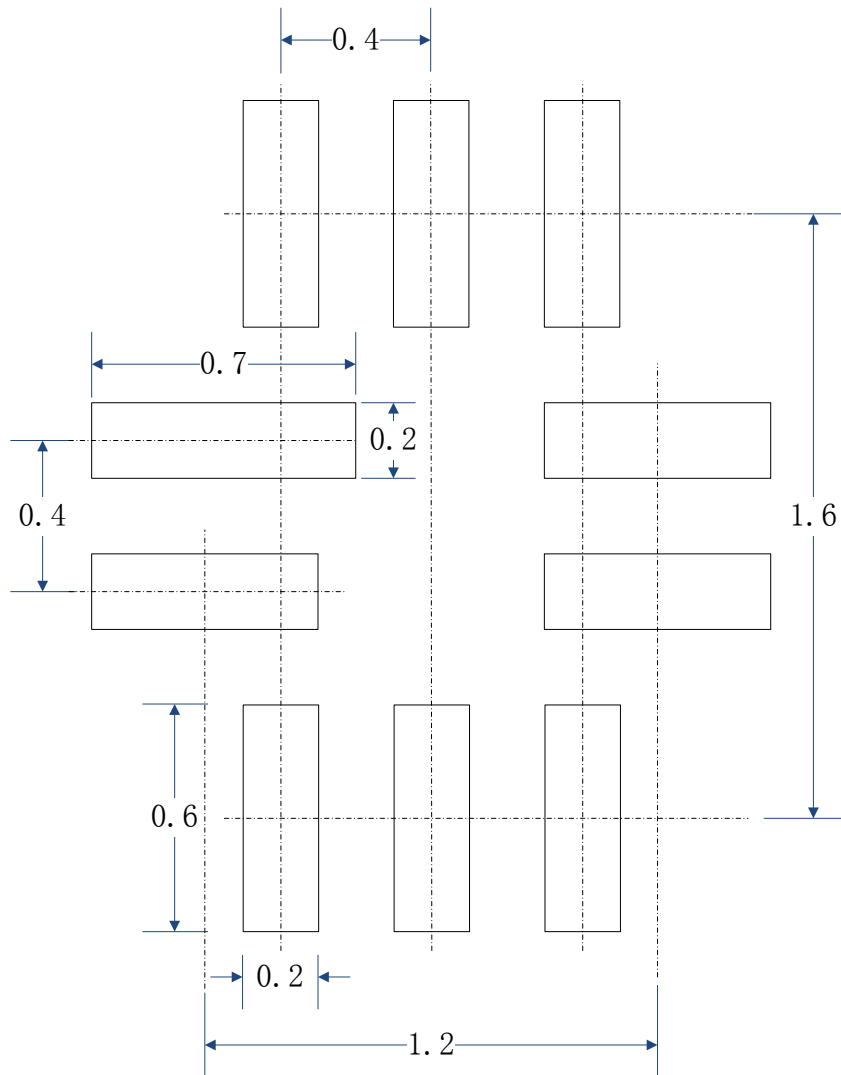

RECOMMENDED PCB LAYOUT PATTERN (Unit: mm)

单击下面可查看定价，库存，交付和生命周期等信息

[>>Broadchip\(广芯电子\)](#)