



BCT4699

0.5Ω Quad-SPDT Analog Switch

BCT4699

0.5Ω Quad-SPDT Analog Switch

GENERAL DESCRIPTION

The BCT4699 is configured as a quad-SPDT switch with two common control inputs. Each digital input controls two pairs of SPDT switches. The switches are fully bi-directional, allowing both multiplexing and de-multiplexing operation. Break-before-make operation is guaranteed.

The device operates from a +1.8V to +5.0V supply and over the extended -40°C to +85°C temperature range. It is offered in 16-pin 3mm x 3mm TQFN package.

APPLICATIONS

Cell Phones
Digital Still Cameras
PDAs and Palmtop Devices MP3/MP4
Players
PCMCIA Cards
Modems
Hard Drives

FEATURES

- ◆ Low 0.5Ω RON (+2.7Vsupply)
- ◆ 0.05Ω On-Resistance Flatness
- ◆ Excellent 0.05Ω On-Resistance Matching
- ◆ Low 0.02% THD into 8Ω
- ◆ Low 0.015% THD into 32Ω
- ◆ Rail-to-Rail Signal Switching Range
- ◆ Fast Switching Speed: 20nsTYP at 3.3V
- ◆ High Off Isolation: -66dB
- ◆ Crosstalk Rejection: -86dB
- ◆ -3dB bandwidth: 100MHz
- ◆ Audio Signal Routing
- ◆ Space-Saving TQFN3x3-16L or UTQFN1.8x2.6-16L Package

ORDERING INFORMATION

Order Number	Package Type	Temperature Range	Marking	QTY/Reel
BCT4699ETE-TR	TQFN3x3-16L	-40°C to +85°C	4699	3000
BCT4699EFE-TR	UTQFN1.8x2.6-16L	-40°C to +85°C	4699	3000

PIN CONFIGURATION(Top View)

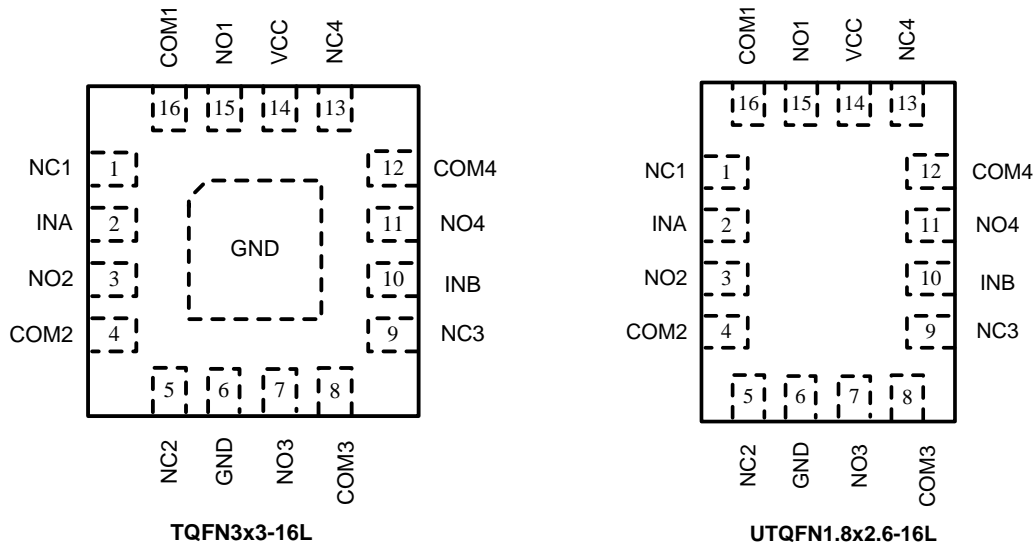

PIN DESCRIPTION

Pin	Name	Function
1	NC1	Normally Closed Terminal Switch 1
2	INA	Select Input, control switch 1 and switch 2
3	NO2	Normally Open Terminal Switch 2
4	COM2	Common Terminal Switch 2
5	NC2	Normally Closed Terminal Switch 2
6	GND	Ground
7	NO3	Normally Open Terminal Switch 3
8	COM3	Common Terminal Switch 3
9	NC3	Normally Closed Terminal Switch 3
10	INB	Select Input, control switch 3 and switch 4
11	NO4	Normally Open Terminal Switch 4
12	COM4	Common Terminal Switch 4
13	NC4	Normally Closed Terminal Switch 4
14	VCC	Positive Power Supply
15	NO1	Normally Open Terminal Switch 1
16	COM1	Common Terminal Switch 1

LOGIC DIAGRAM

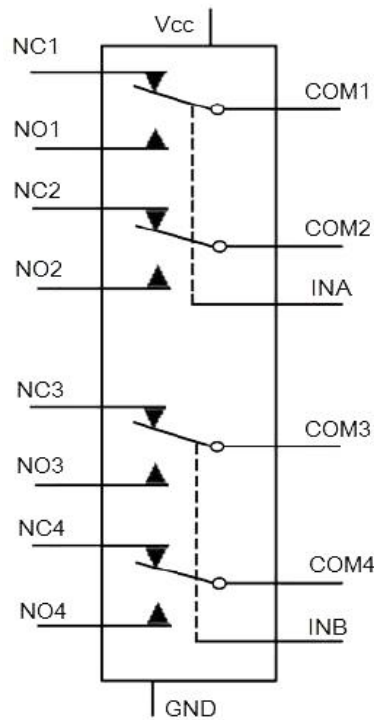

TRUTH TABLE

INA	SWITCH STATE
0	NC1 = COM1, NC2 = COM2
1	NO1 = COM1, NO2 = COM2

INB	SWITCH STATE
0	NC3 = COM3, NC4 = COM4
1	NO3 = COM3, NO4 = COM4



BCT4699

0.5Ω Quad-SPDT

Analog Switch

ABSOLUTE MAXIMUM RATINGS

VCC, INA, INB to GND.....-0.3V to +6.0V
 All Other Pins to GND (Note 1).....-0.3V to (VCC + 0.3V)
 Continuous Current (NO₋, NC₋, COM₋)..... ±400mA
 Peak Current (NO₋, NC₋, COM₋)
 (pulsed at 1ms, 10% duty cycle).....±500mA

Continuous Power Dissipation (TA = +70°C)
 16-Pin TQFN (15.6mW/°C above +70°C)1.25W
 Operating Temperature Range-40°C to +85°C
 Storage Temperature Range.....-65°C to +150°C
 Junction Temperature.....+150°C
 Lead Temperature (soldering, 10s).....+300°C

Note 1: Signals on NO₋, NC₋, COM₋, INA and INB exceeding VCC or GND are clamped by internal diodes. Limit forward-diode current to maximum current rating.

Stresses beyond those listed under "Absolute Maximum Ratings" may cause permanent damage to the device. These are stress ratings only, and functional operation of the device at these or any other conditions beyond those indicated in the operational sections of the specifications is not implied. Exposure to absolute maximum rating conditions for extended periods may affect device reliability.

ELECTRICAL CHARACTERISTICS

(VCC = 2.7V to 4.2V, TA = TMIN to TMAX, unless otherwise noted. Typical values are at VCC = 3V, TA = +25°C. (Note 2)

Parameter	Symbol	Conditions	Min	Typ	Max	Units
POWER SUPPLY						
Supply Voltage Range	VCC		1.8		5.0	V
Supply Current	ICC	VCC= 3.6V, VIN ₋ = 0 or VCC, NO ₋ = NC ₋ = COM ₋ = floating		0.02	1	µA
ANALOG SWITCH						
Analog Signal Range		NO ₋ , NC ₋ , COM ₋	0		VCC	V
On-Resistance	RON	VCC= 2.7V, ICOM ₋ = 100mA, VNO ₋ or VNC ₋ = 0 to VCC(3)	TA = +25°C	0.5	0.8	Ω
			TA= TMIN to TMAX		0.9	
On-Resistance Match	ΔRON	VCC= 2.7V, ICOM ₋ = 100mA, VNO ₋ or VNC ₋ = 1.5V(3,4)	TA = +25°C	0.05	0.09	Ω
			TA= TMIN to TMAX		0.1	
On-Resistance Flatness	RFLAT	VCC= 2.7V; ICOM ₋ = 100mA; VNO ₋ or VNC ₋ = 0.6V, 1.2V, 1.8V(5)	TA = +25°C	0.06	0.1	Ω
			TA= TMIN to TMAX		0.12	
NO ₋ or NC ₋ Off-Leakage Current	IOFF	VCC= 3.3V; VCOM ₋ = 3V, 0.3V or floating; VNO ₋ or VNC ₋ = 0.3V, 3V or floating	TA = +25°C		20	nA
			TA= TMIN to TMAX		100	
COM ₋ On-Leakage Current	ION	VCC= 3.3V; VNO ₋ or VNC ₋ = 0.3V, 3V or floating; VCOM ₋ = 0.3V, 3V or floating	TA = +25°C		20	nA
			TA= TMIN to TMAX		100	

ELECTRICAL CHARACTERISTICS

(V_{CC} = 2.7V to 4.2V, T_A = T_{MIN} to T_{BCT}, unless otherwise noted. Typical values are at V_{CC} = 3V, T_A = +25°C.) (2)

Parameter	Symbol	Conditions	Min	Typ	Max	Units
DYNAMIC CHARACTERISTICS						
Turn-On Time	T _{ON}	V _{CC} = 2.7V, V _{NO_orVNC_} = 1.5V, R _L = 50Ω, C _L = 35pF, Figure 1	T _A = +25°C	20	30	ns
			T _A = T _{MIN} to T _{MAX}		50	
Turn-Off Time	T _{OFF}	V _{CC} = 2.7V, V _{NO_orVNC_} = 1.5V, R _L = 50Ω, C _L = 35pF, Figure 1	T _A = +25°C	15	40	ns
			T _A = T _{MIN} to T _{MAX}		50	
Break-Before-Make Time	t _{BBM}	V _{CC} = 2.7V, V _{NO_orVNC_} = 1.5V, R _L = 50Ω, C _L = 35pF, Figure 2(6)	T _A = +25°C	2	15	ns
			T _A = T _{MIN} to T _{MAX}	2		
Charge Injection	Q	V _{GEN} = 0V, R _{GEN} = 0Ω, C _L = 1nF, Figure 3		100		pC
On-Channel Bandwidth -3dB	BW	R _L = 50Ω, Figure 4		100		MHz
Off-Isolation	V _{ISO}	V _{COM_} = 1VRMS, R _L = 50Ω, f = 100kHz, C _L = 5pF, Figure 4(7)		-66		dB
Crosstalk	V _{CT}	V _{COM_} = 1VRMS, R _L = 50Ω, f = 100kHz, C _L = 5pF, Figure 4(8)		-86		dB
Total Harmonic Distortion Plus Noise	THD+N	f = 20Hz to 20kHz; V _{NC_} , V _{NO_} , V _{COM_} = 0.5VP-P; R _L = 32Ω		0.02		%
NC_ or NO_ Off-Capacitance	C _{NC_(OFF)} , C _{NO_(OFF)}	f = 1MHz, V _{NO_} = V _{NC_} = V _{COM_} = 1.5V, Figure 5		25		pF
COM_ On-Capacitance	C _{COM_(ON)}	f = 1MHz, V _{NO_} = V _{NC_} = V _{COM_} = 1.5V, Figure 5		60		pF
Power-Supply Rejection Ratio	PSRR	V _{AC} = 100mVP-P, V _{COM_} = 1.5V, R _L = 50Ω, f = 100kHz		-34		dB
DIGITAL INPUTS						
Input-Logic High	V _{IH}	V _{CC} = 2.7V to 4.2V,	1.4			V
Input-Logic Low	V _{IL}		0.5			V
Input Leakage Current	I _{IN}	V _{IN_} = 0 or V _{CC} ,			±1	uA

Note 2: Devices are 100% tested at T_A = +25°C. Limits across the full temperature range are guaranteed by design and correlation.

Note 3: R_{ON} and RON matching specifications are guaranteed by design for BCT4699ETE only.

Note 4: ΔR_{ON} = R_{ON}(MAX) - R_{ON}(MIN).

Note 5: Flatness is defined as the difference between the maximum and minimum value of on-resistance, as measured over the specified analog signal ranges.

Note 6: Guaranteed by design, not production tested.

Note 7: Off-isolation = 20log₁₀ [V_{COM_} / (V_{NO_} or V_{NC_})], V_{COM_} = output, V_{NO_} or V_{NC_} = input to off switch.

Note 8: Between any two switches.

Timing Circuits/Timing Diagrams

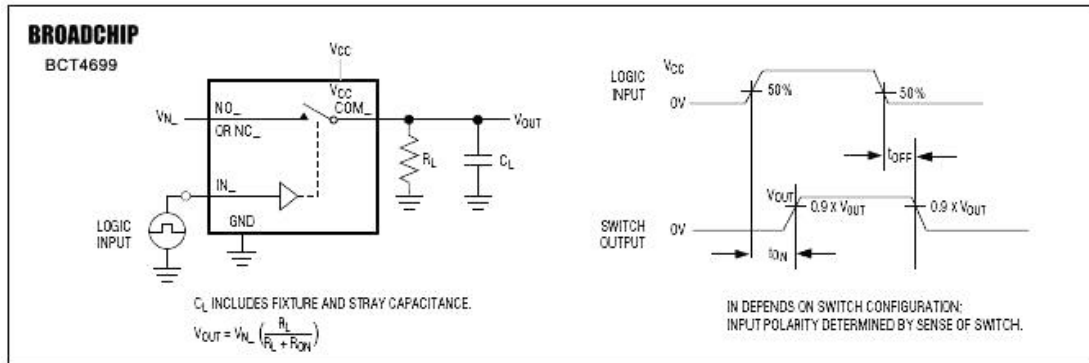

Figure 1. Switching Time

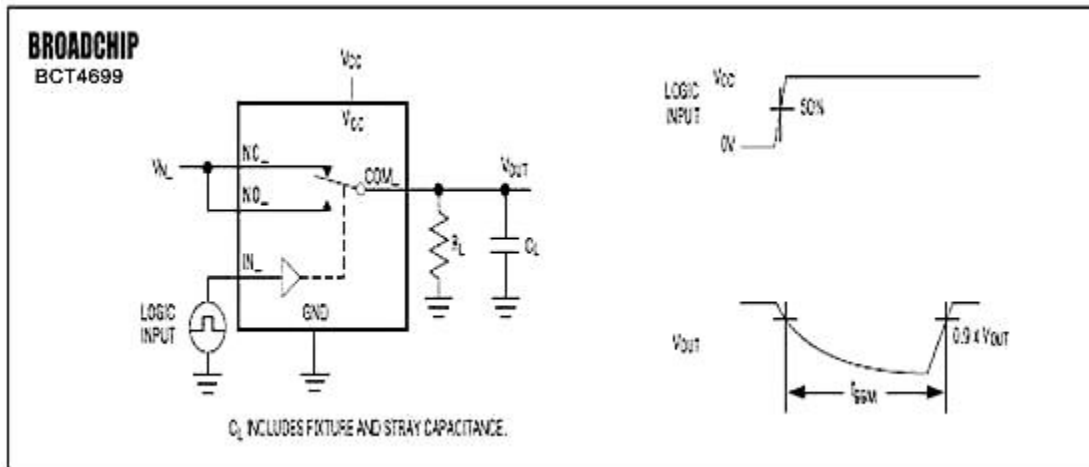

Figure 2. Break-Before-Make Interval

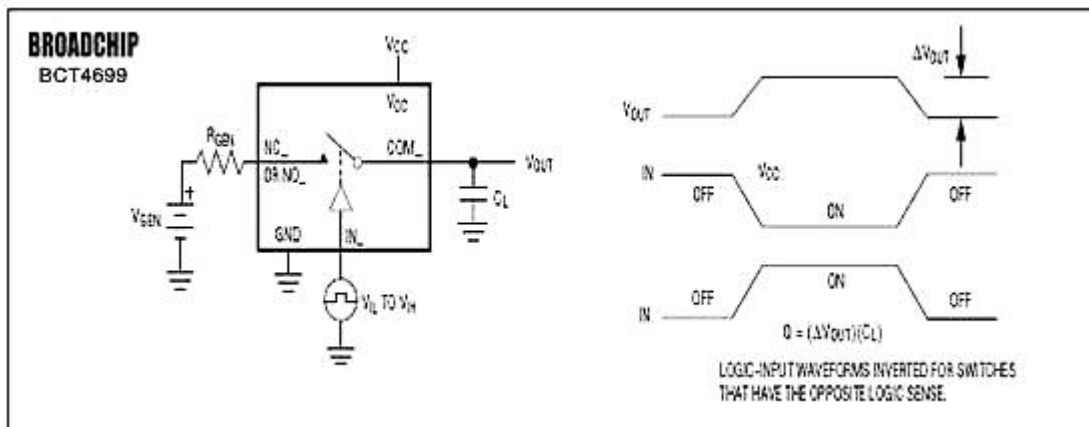

Figure 3. Charge Injection

Timing Circuits/Timing Diagrams(continued)

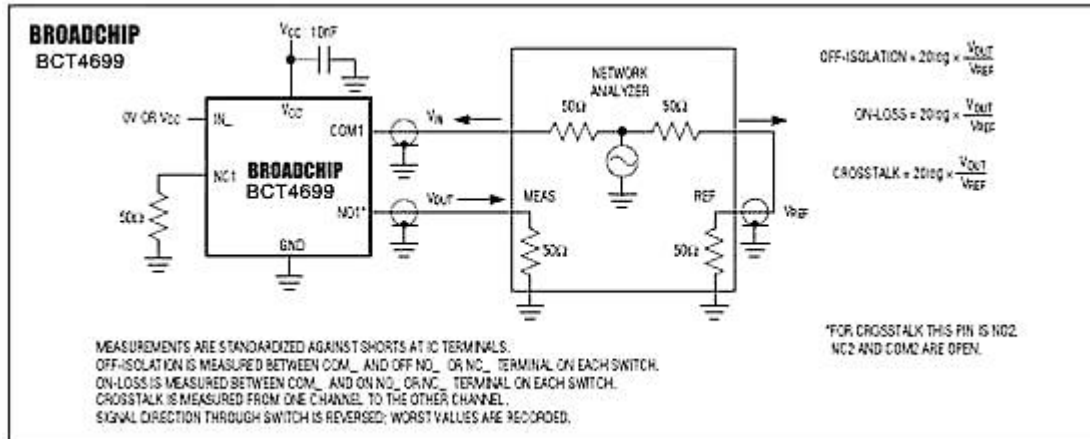

Figure 4. On-Loss, Off-Isolation, and Crosstalk

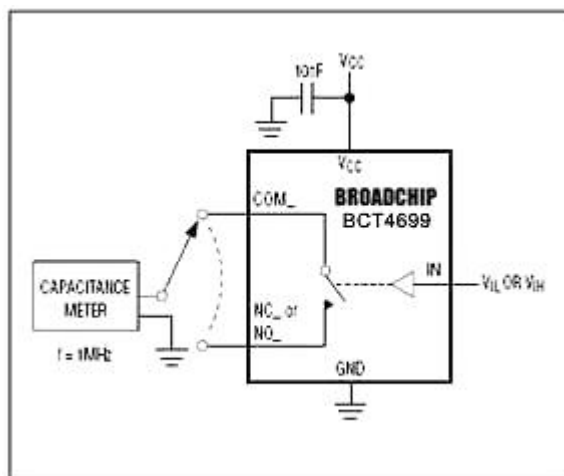
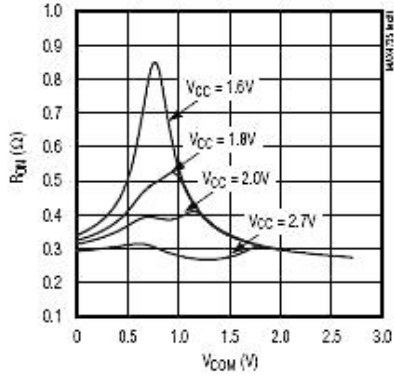

Figure 5. Channel On-/Off-Capacitance

Typical Operating Characteristics

(VCC = 3V, TA = +25°C, unless otherwise noted.)

ON-RESISTANCE vs. COM_ VOLTAGE



ON-RESISTANCE vs. COM_ VOLTAGE

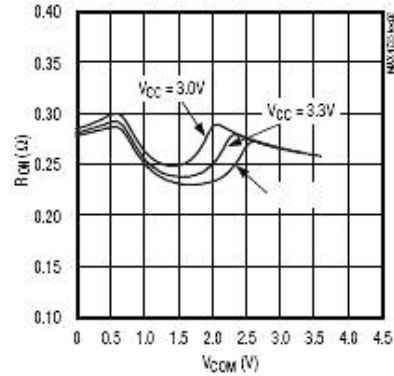

ON-RESISTANCE vs. COM_ VOLTAGE AND TEMPERATURE

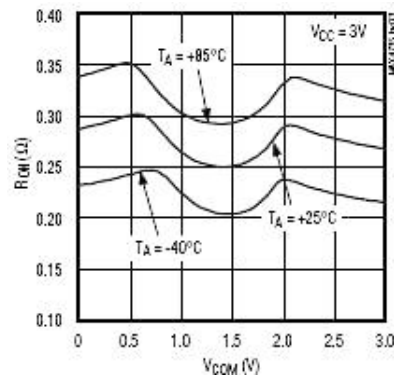

SUPPLY CURRENT vs. TEMPERATURE

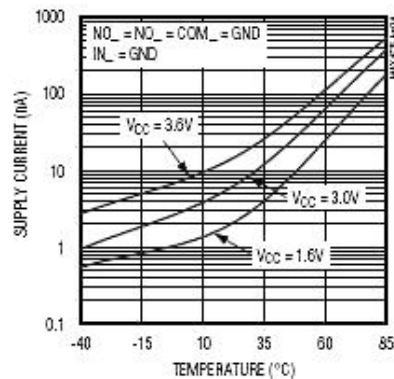

NO_ /NC_ OFF-LEAKAGE CURRENT vs. TEMPERATURE

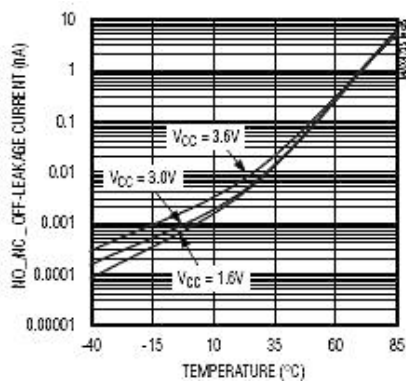

COM_ ON-LEAKAGE CURRENT vs. TEMPERATURE

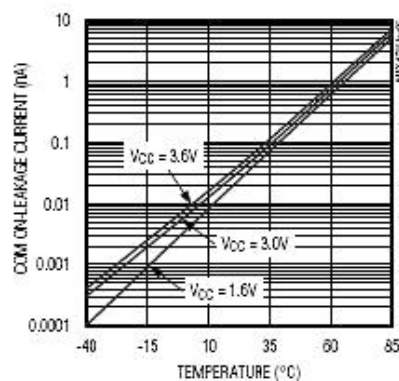

TURN-ON/OFF TIME vs. SUPPLY VOLTAGE

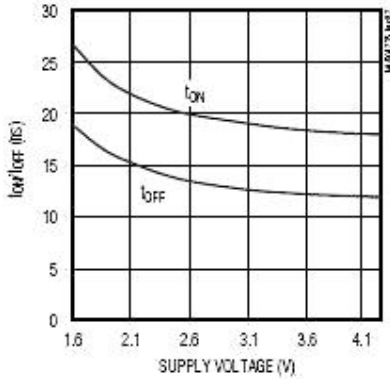

TURN-ON/OFF TIME vs. TEMPERATURE

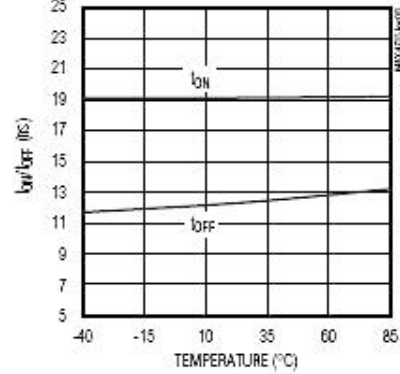

CHARGE INJECTION vs. COM_ VOLTAGE

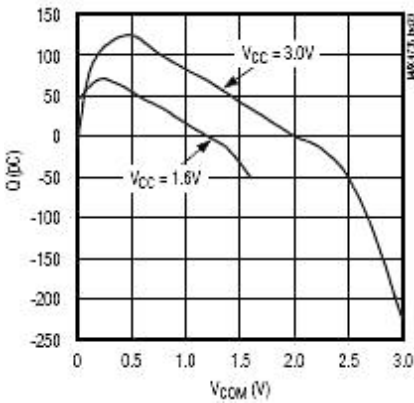

COM_ ON-CAPACITANCE vs. COM_ VOLTAGE

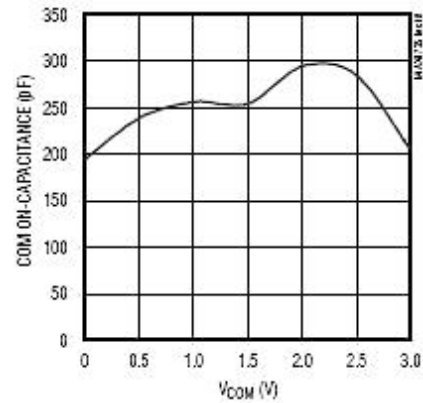

NO_ OFF-CAPACITANCE vs. NO_ VOLTAGE

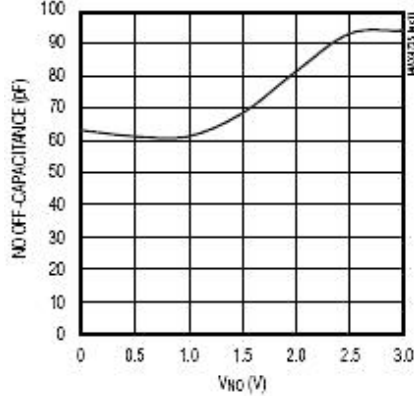

NO_ ON-CAPACITANCE vs. NO_ VOLTAGE

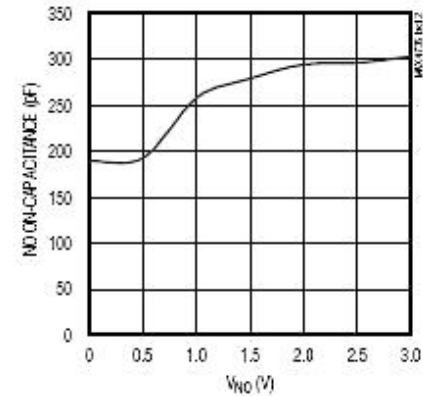

ON-RESPONSE vs. FREQUENCY

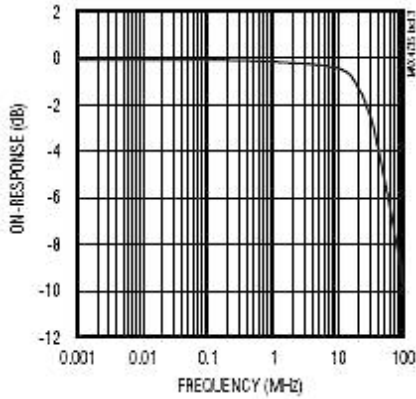

OFF-ISOLATION AND CROSSTALK vs. FREQUENCY

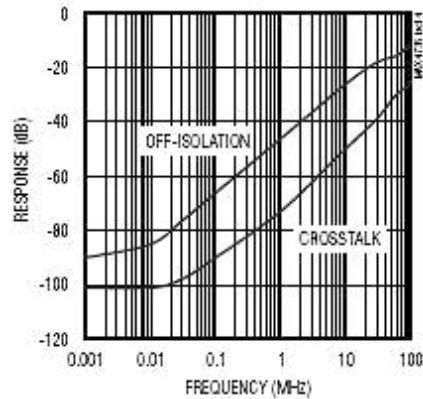

TOTAL HARMONIC DISTORTION PULSE NOISE vs. SIGNAL AMPLITUDE

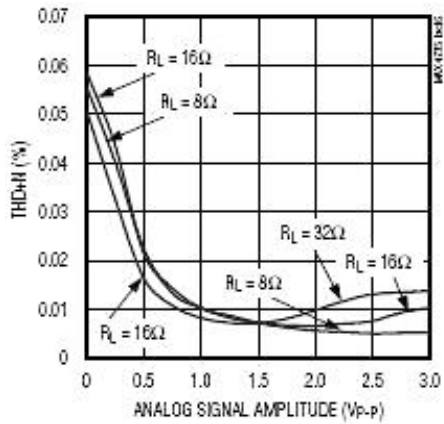

POWER-SUPPLY REJECTION RATIO vs. FREQUENCY

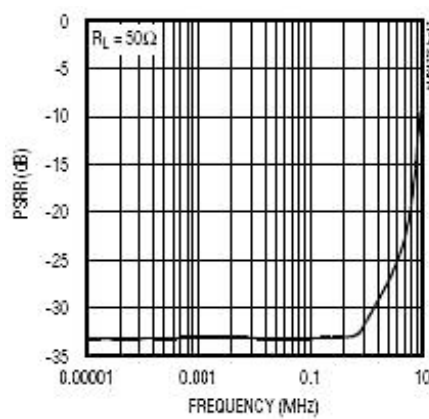

Detailed Description

The BCT4699 quad-SPDT analog switch operates from a single +1.8V to +5.5V supply. These devices are fully specified for +3V applications. The BCT4699 features fully bidirectional, rail-to-rail CMOS analog switch channels. They can be configured as dual-DPDT switches, dual 4:2 multiplexers/de-multiplexers, or as a single 8:4 multiplexer/de-multiplexer.

Applications Information

As seen in the Typical Operating Characteristics, the on-resistance of the BCT4699 is inversely proportional to the supply voltage. Best performance is obtained by using the highest supply voltage available within the +1.8V to +5.5V range.

Digital Logic Inputs

Digital control inputs INA and INB control the position of the switches in the BCT4699. These inputs are diode clamped to GND only. It is acceptable to leave these pins driven in the absence of a V_{CC} power supply.

For best performance, drive INA and INB to the full supply voltage range of the BCT699.

The two switch sections of the BCT4699 operate independently. Drive INA low to connect COM1 to NC1 and connect COM2 to NC2. Drive INA high to connect COM1 to NO1 and connect COM2 to NO2. Drive INB low to connect COM3 to NC3 and connect COM4 to NC4. Drive INB high to connect COM3 to NO3 and connect COM4 to NO4. See Table 1.

INA and INB have typical hysteresis of 100mV by including positive feedback in the internal buffer. Thus, for applications using DC or very slow ramp rate of the digital input voltage level, connect a 100pF capacitor from IN₋ to GND to limit the I_{CC} current at the trip point. The switching point is typically 0.7V between V_{IL} and V_{IH} levels.

Power Supply

The BCT4699 operates from a +1.8V to +5.5V power supply. For best results, bypass V_{CC} to GND with a 0.1μF ceramic chip capacitor located close to the IC.

Audio Signal Routing

The BCT4699's low R_{ON} makes it an excellent choice for multiplexing loudspeakers in portable equipment. THD performance is inversely proportional to load impedance.

Within the audio signal range, there is no frequency component to THD. The only distortion mechanism is the R_{ON} flatness' modulation of the signal into a load. Therefore, for best distortion performance, use higher impedance transducers.

Analog Signal Range

The CMOS switches in the BCT4699 function on any signal within the power-supply voltages. If any channel exceeds V_{CC} , it is clamped to V_{CC} by a silicon diode. If any channel goes below GND, it is clamped to GND by a silicon diode. Ensure that if either of these diodes becomes forward biased, the continuous and peak currents do not exceed those listed in the Absolute maximum Ratings section of this datasheet.

Table 1. Truth Table

INA	INB	SWITCH 1 AND SWITCH 2 STATE	SWITCH 3 AND SWITCH 4 STATE
0	—	COM1 to NC1 COM2 to NC2	—
1	—	COM1 to NO1 COM2 to NO2	—
—	0	—	COM3 to NC3 COM4 to NC4
—	1	—	COM3 to NO3 COM4 to NO4

Each switch channel on the BCT4699 has an absolute maximum rating 300mA continuous current, and 400mA peak current at 50% duty cycle. When driving low-impedance loudspeakers, the peak signal amplitude should be limited so these peak currents are not exceeded. For an 8Ω load, this corresponds to 2.3V_{RMS}. For a 4Ω load, this is 1.1V_{RMS}.

Package Information

The BCT4699 is offered in 16-pin 3mm x 3mm x 0.8mm TQFN packages. The mechanical drawings for these packages are located at the end of this data sheet.

The TQFN package is rated for a peak power dissipation of 1.25W at +70°C, with a θ_{JA} of 64°C/W on a single-layer PC board.

PACKAGE OUTLINE DIMENSIONS: TQFN 3x3-16L

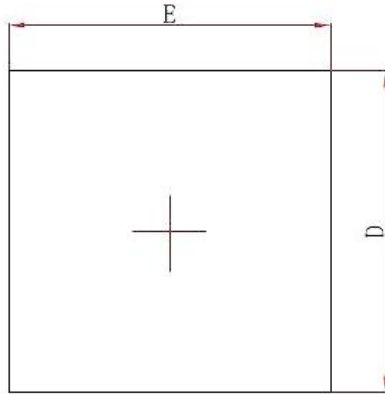

Top View

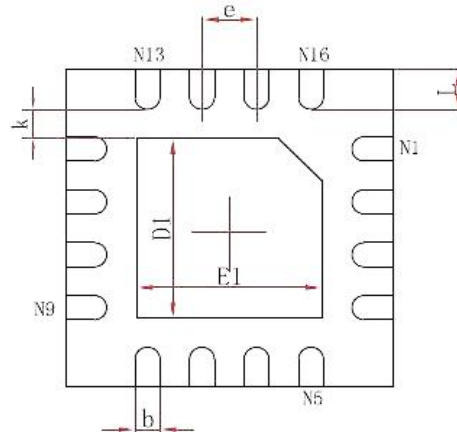

Bottom View

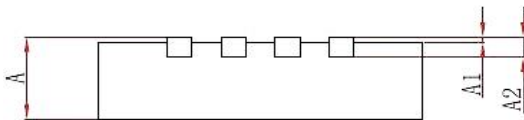

Side View

Symbol	Dimensions In Millimeters		Dimensions In Inches	
	Min.	Max.	Min.	Max.
A	0.700/0.800	0.800/0.900	0.028/0.031	0.031/0.035
A1	0.000	0.050	0.000	0.002
A2	0.153	0.253	0.006	0.010
D	2.900	3.100	0.114	0.122
E	2.900	3.100	0.114	0.122
D1	1.600	1.800	0.063	0.071
E1	1.600	1.800	0.063	0.071
k	0.200MIN.		0.008MIN.	
b	0.180	0.300	0.007	0.012
e	0.500TYP.		0.500TYP.	
L	0.300	0.500	0.012	0.020

PACKAGE OUTLINE DIMENSIONS: UTQFN 1.8x2.6 -16L

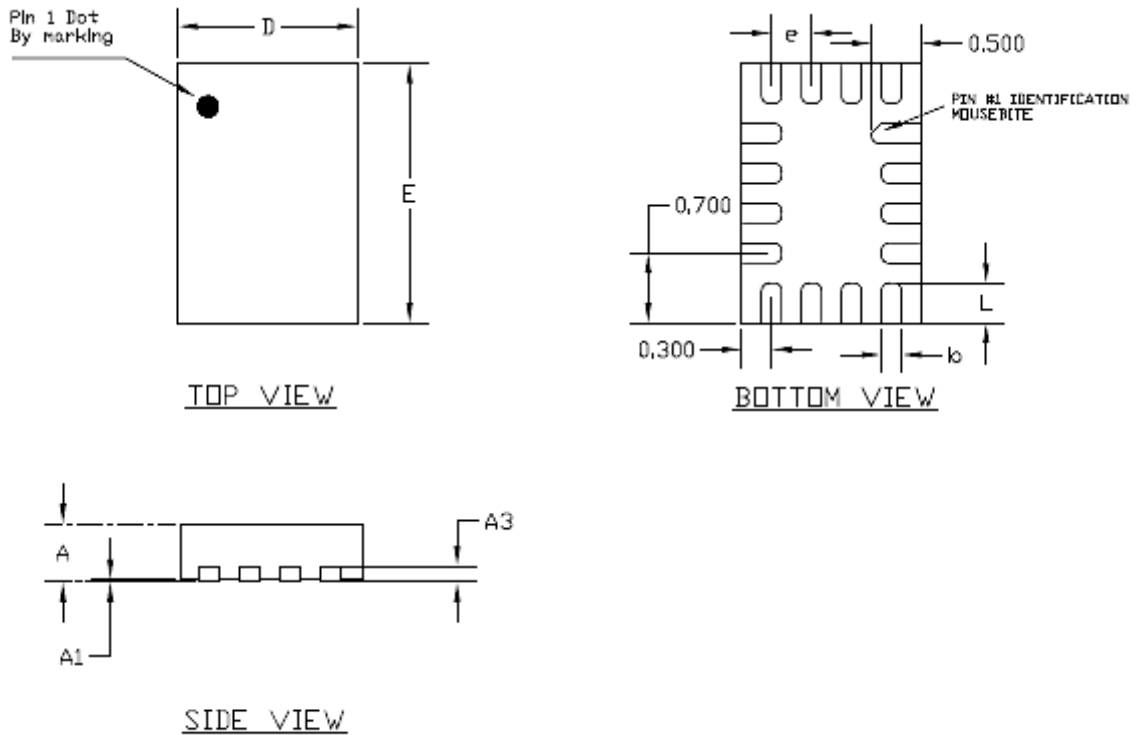

COMMON DIMENSIONS(MM)			
PKG.	UT:ULTRA THIN		
REF.	MIN.	NOM.	MAX
A	>0.50	0.55	0.60
A1	0.00	-	0.05
A3	0.15 REF.		
D	1.75	1.80	1.85
E	2.55	2.60	2.65
L	0.30	0.40	0.50
b	0.15	0.20	0.25
e	0.40 BSC		

单击下面可查看定价，库存，交付和生命周期等信息

[>>Broadchip\(广芯电子\)](#)