



# BCT3364

## 4 Channel LED Driver

### With Digital Pulse Brightness Control

# BCT3364

## 4 Channel LED Driver

### With Digital Pulse Brightness Control

#### GENERAL DESCRIPTION

The BCT3364 is a high performance white LED driver. The BCT3364 uses an internal resistor to set the bias current for four LEDs, which are matched to 1.5%. The BCT3364's advantages over ballast resistors include much lower bias variation with supply voltage variation, significantly lower dropout voltage, and in some applications, significantly improved efficiency. The BCT3364 requires only a 50mV dropout voltage at a 20mA load on each output to match the LED brightness.

Users can easily configure the LED current from 1.25mA to 20mA by a serial pulse. The Dimming of white LEDs current can be achieved by applying a pulse signal to the EN pin. There are totally 16 steps of current could be set by users. Internal soft start circuitry effectively reduces the in-rush current while both start-up and mode transition.

#### FEATURES

- ◆ 2.7V to 5.5V Supply Voltage Range
- ◆ 16-Step Brightness Control With One Wire interface
- ◆ 20mA full scale current
- ◆ 1.5% LED Current Matching (TYP)
- ◆ Low 50mV Dropout at 20mA
- ◆ Thermal Shutdown Protection
- ◆ Low Input Noise and EMI
- ◆ RoHS Compliant and 100% Lead (Pb)-Free, DFN2x2-8L Package

#### APPLICATIONS

- Cell Phones
- PDA's
- Digital Cameras, Camcorders
- Portable Instrumentation
- Battery Powered Equipment

#### ORDERING INFORMATION

Order Number	Package Type	Temperature Range	Marking	QTY/Reel
BCT3364ELA-TR	DFN2x2-8L	-40°C to +85°C	3364 XXXXX	3000

Note: "XXXXX" in Marking will be appeared as the batch code.

### PIN CONFIGURATION (Top View)

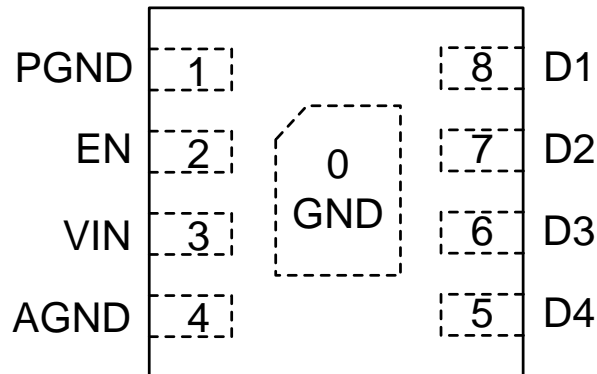

DFN2x2-8L

### PIN DESCRIPTION

PIN	NAME	FUNCTION
1	PGND	Ground
2	EN	Chip Enable (Active High), and connects to GPIO pin of MCU.
3	VIN	Input voltage
4	AGND	Ground
5	D4	LED Pin4, leave it NC if unused.
6	D3	LED Pin3, leave it NC if unused.
7	D2	LED Pin2, leave it NC if unused.
8	D1	LED Pin1, leave it NC if unused.
0	GND	Ground

### TYPICAL APPLICATION CIRCUIT

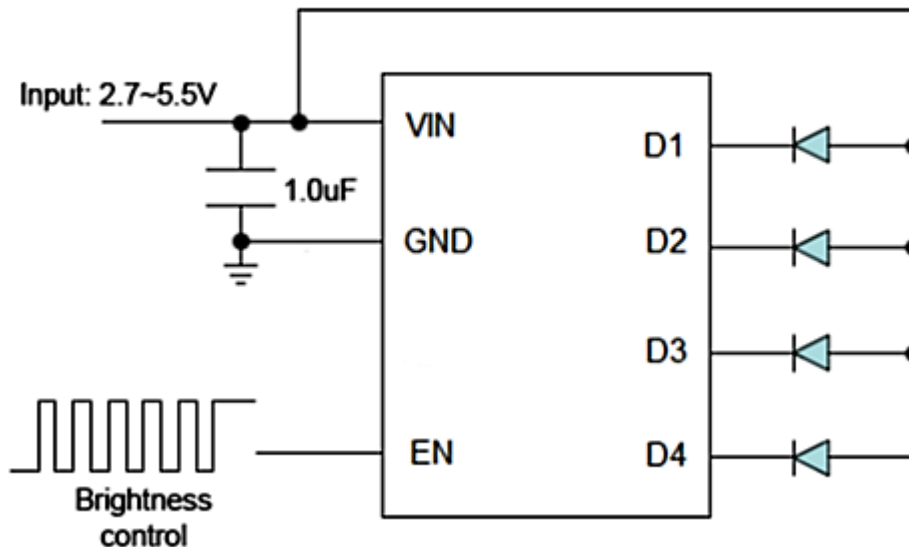

### ABSOLUTE MAXIMUM RATINGS

VIN to GND.....	-0.3V to 6V
All Other Pins to GND .....	-0.3V to (VCC + 0.3V)
Continuous Current (D1- D4).....	±30mA
Continuous Power Dissipation (TA=+25°C)	
DFN2x2-8L .....	0.96W
Package Thermal Resistance $\theta_{JA}$	
DFN2x2-8L .....	120°C/W
Operating Temperature Range.....	-40°C to +85°C
Storage Temperature Range.....	-65°C to +150°C
Junction Temperature.....	+150°C
Lead Temperature (soldering, 10s).....	+260°C

**NOTE:**

Stresses beyond those listed under "Absolute Maximum Ratings" may cause permanent damage to the device. These are stress ratings only, and functional operation of the device at these or any other conditions beyond those indicated in the operational sections of the specifications is not implied. Exposure to absolute maximum rating conditions for extended periods may affect device reliability.

### CAUTION

This integrated circuit can be damaged by ESD if you don't pay attention to ESD protection. Broadchip recommends that all integrated circuits be handled with appropriate precautions. Failure to observe proper handling and installation procedures can cause damage. ESD damage can range from subtle performance degradation to complete device failure. Precision integrated circuits may be more susceptible to damage because very small parametric changes could cause the device not to meet its published specifications.

Broadchip reserves the right to make any change in circuit design, specification or other related things if necessary without notice at any time. Please contact Broadchip sales office to get the latest datasheet.



# BCT3364

## 4 Channel LED Driver

### With Digital Pulse Brightness Control

#### ELECTRICAL CHARACTERISTICS

( $V_{IN}$  = 2.7 to 5.5V,  $T_A$  = 25°C, unless otherwise specified.)

PARAMETER	SYM	CONDITIONS	MIN	TYP	MAX	UNITS
<b>POWER SUPPLY</b>						
Input Voltage	$V_{IN}$		2.7		5.5	V
Supply Current	$I_{CC}$	$V_{IN}=3.6V, EN=HIGH$		150	200	uA
Shut Down Current	$I_{SHUT}$	EN=LOW			1	uA
<b>Analog Outputs</b>						
Drop Out Voltage	$V_{DROP}$	$I_{LED}= 20mA, VD_ - GND$		50	75	mV
Current Accuracy	$I_D$	$V_{OUT}=0.6V$	18	20	22	mA
Current Matching Between Channels	$\Delta I_D$	$V_{OUT}=0.6V$		1.5	3	%
<b>Logic Inputs (EN)</b>						
Input-Logic High	$V_{IH}$		1.4			V
Input-Logic Low	$V_{IL}$				0.4	V
Input Leakage Current	$I_{IN}$	$V_{IN} = 0$ or $V_{CC}$	-1		1	uA
EN Low Time for Shutdown	$T_{SHDN}$				3	ms
EN Low for Dimming	$T_{LO}$		0.5		500	us
EN High for Dimming	$T_{HI}$		0.5			us
IC junction thermal shutdown threshold	$T_J$			155		°C

NOTES: Devices are 100% tested at  $T_A = +25^\circ C$ . Limits across the full temperature range are guaranteed by design and correlation.

#### Brightness Control by Pulse Dimming

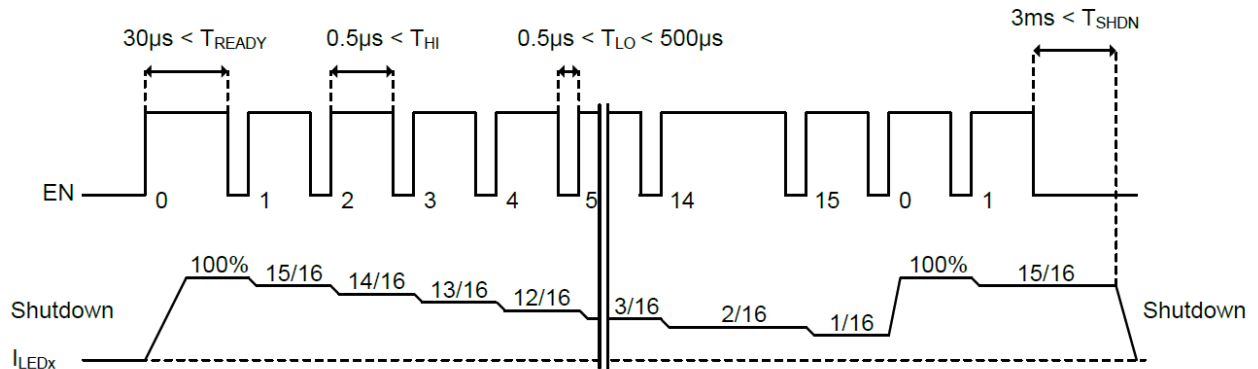

Number of Pulse Falling Edge	IO <sub>UT</sub> (mA)
0	20
1	18.75
2	17.5
3	16.25
4	15
5	13.75
6	12.5
7	11.25
8	10
9	8.75
10	7.5
11	6.25
12	5
13	3.75
14	2.5
15	1.25

## PACKAGE OUTLINE DIMENSIONS

DFN2x2-8L

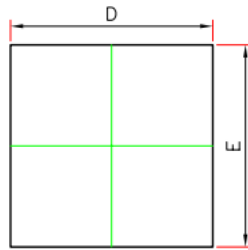

TOP VIEW

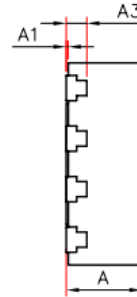

SIDE VIEW

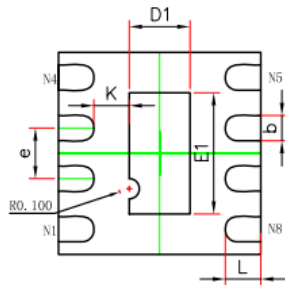

BOTTOM VIEW

Symbol	Dimensions In Millimeters		Dimensions In Inches	
	Min.	Max.	Min.	Max.
A	0.700	0.800	0.028	0.031
A1	0.000	0.050	0.000	0.002
A3	0.203REF.		0.008REF.	
D	1.900	2.100	0.075	0.083
E	1.900	2.100	0.075	0.083
D1	0.500	0.700	0.020	0.028
E1	1.100	1.300	0.043	0.051
k	0.350REF.		0.014REF.	
b	0.200	0.300	0.008	0.012
e	0.500BSC.		0.020BSC.	
L	0.274	0.426	0.011	0.017

---

**LAND PATTERN DATA**

DFN2x2-8L

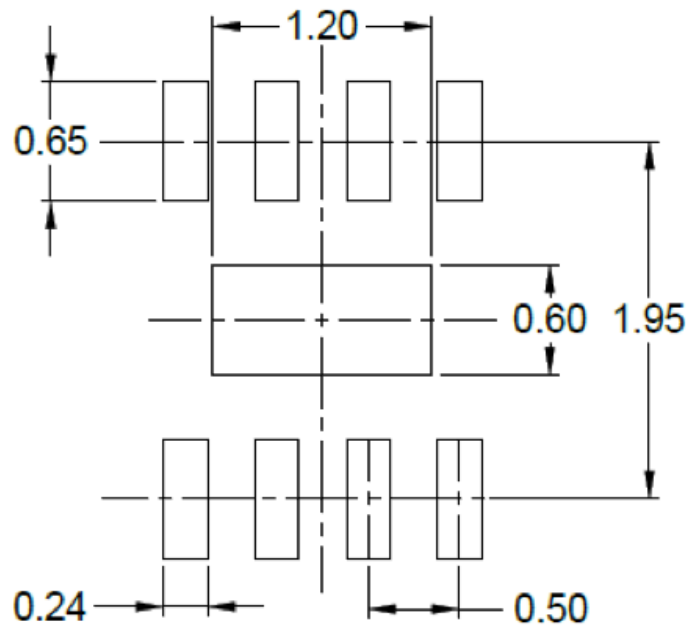

**RECOMMENDED PCB LAYOUT PATTERN** (Unit: mm)

单击下面可查看定价，库存，交付和生命周期等信息

[>>Broadchip\(广芯电子\)](#)