



## Specification for Approval

- DEVICE NUMBER: BPD-BQBA31
- CUSTOMER:

SAMPLES  
ATTACHED AREA

DATE \ PAGE	1	2	3	4	5	CONTENTS			
2017/3/9	1.0	1.0	1.0	1.0	1.0	Initial Released			
2022/10/12	1.1	1.1	1.1	1.1	1.1	Modify Electrical Characteristics			

### FOR CUSTOMER'S APPROVAL STAMP OR SIGNATURE

APPROVED	PURCHASE	MANUFACTURE	QUALITY	ENGINEERING

佰鴻工業股份有限公司  
 BRIGHT LED ELECTRONICS CORP.  
 新北市板橋區和平路 19 號 3 樓  
 3F., No.19, He Ping Road,  
 Ban Qiao Dist., New Taipei City,  
 Taiwan  
 Tel: +886-2-29591090  
 Fax: +886-2-29547006/29558809  
[www.brtled.com](http://www.brtled.com)

Approved By	Confirmed By	Prepared By
		

## END-LOOK PACKAGE PIN PHOTO DIODE

### I Features

1. Linear response vs. irradiance
2. Fast switching time
3. End-looking Package ideal for space limited applications
4. Lens Appearance: Black
5. This product doesn't contain restriction Substance, comply RoHS standard.

### I Description

The BPD-BQBA31 device consists of a PIN silicon photodiode molded in a black epoxy package which allows spectral response infrared light wavelengths.

The receiving angle provides relatively even reception over a large area.

The end-looking package is designed for easy PC board mounting.

This photodiode is mechanically and spectrally matched to BRIGHT's GaAs and GaAlAs series of infrared emitting diodes.

### ● Package Dimensions:

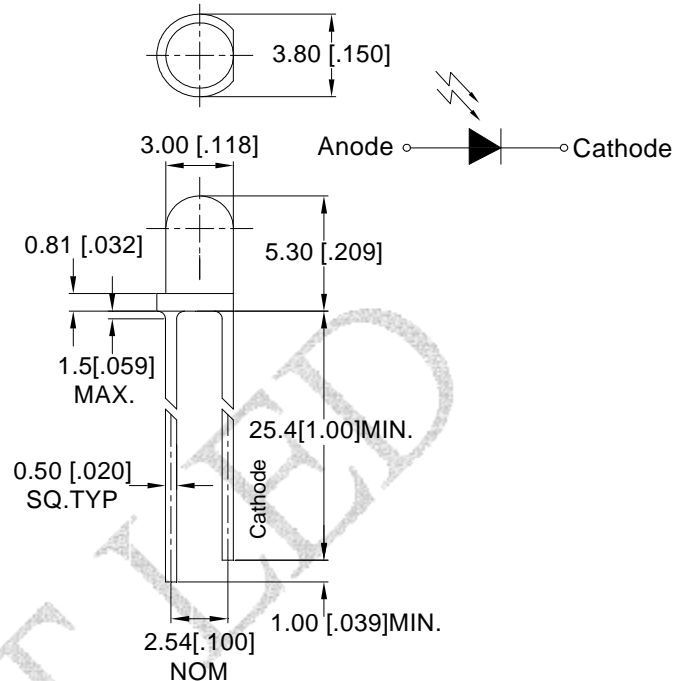

### NOTES:

1. All dimensions are in millimeters (inches).
2. Tolerance is  $\pm 0.25\text{mm}$  (0.01') unless otherwise specified.
3. Lead spacing is measured where the leads emerge from the package
4. Specifications are subject to change without notice

### I Absolute Maximum Ratings (Ta=25°C)

Parameter	Maximum Rating	Unit
Power Dissipation	100	mW
Reverse Breakdown Voltage	60V	
Operating Temperature	-40°C ~ +85°C	
Storage Temperature Range	-45°C ~ +85°C	

### I Electrical Characteristics (Ta=25°C unless otherwise noted)

PARAMETER	SYMBOL	MIN	TYP	MAX	UNITS	TEST CONDITIONS
Reverse Light Current	$I_L$	-	28	-	$\mu A$	$V_R=5V, E_e=1mW/cm^2$
Reverse Dark Current	$I_D$	-	-	30	nA	$V_R=10V, E_e=0 mW/cm^2$
Reverse Break down Voltage	$V_{(BR)}$	35	-	-	V	$I_R=100\mu A$
Forward Voltage	$V_F$	-	-	1.3	V	$I_F=10mA$
Spectral range of sensitivity	$\lambda_{10\%}$	820	940	1100	nm	
Wavelength of max sensitivity	$\lambda_p$		940		nm	
Total Capacitance	$C_T$	-	5	-	PF	$V_R=5V, E_e=0, f=1.0MHZ$
Rise Time/ Fall Time	tr/ tf	-	10	-	ns	$V_R=20V, \lambda=940nm, R_L=50\Omega$
Angle of sensitivity	$2\theta_{1/2}$	-	45	-	deg	

### I Typical Optical-Electrical Characteristic Curves

Fig1. Relative Responsivity vs. Wavelength

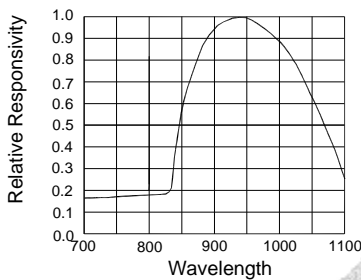

Fig2. Coupling Characteristics

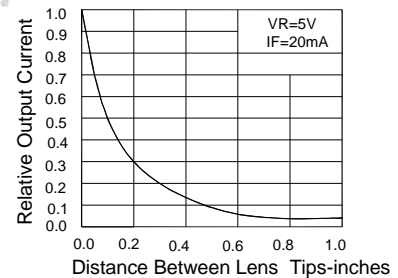

Fig3. Normalized Light Current vs Reverse Voltage

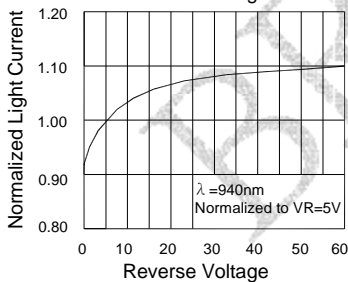

Fig4. Total Capacitance vs Reverse Voltage

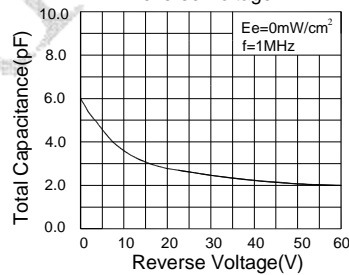

Fig5. Normalized Light Current vs Ambient Temperature

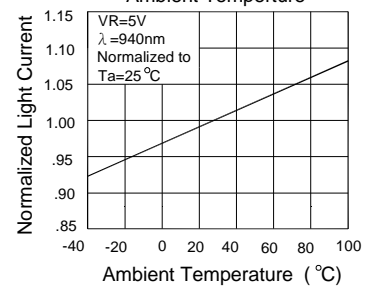

Fig6. Light Current vs Irradiance

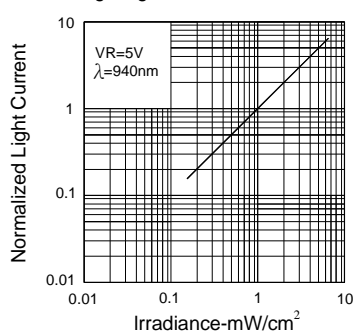
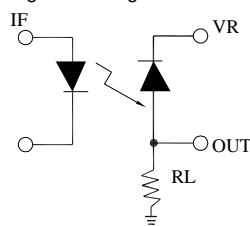
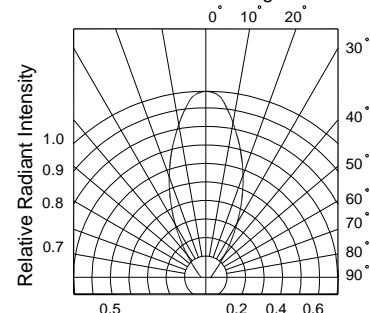

Fig7. Switching Time Test Circuit



Note:  
See Above For tr/ tf Conditions

FIG.8 Radiant Diagram



## ● Dip Soldering

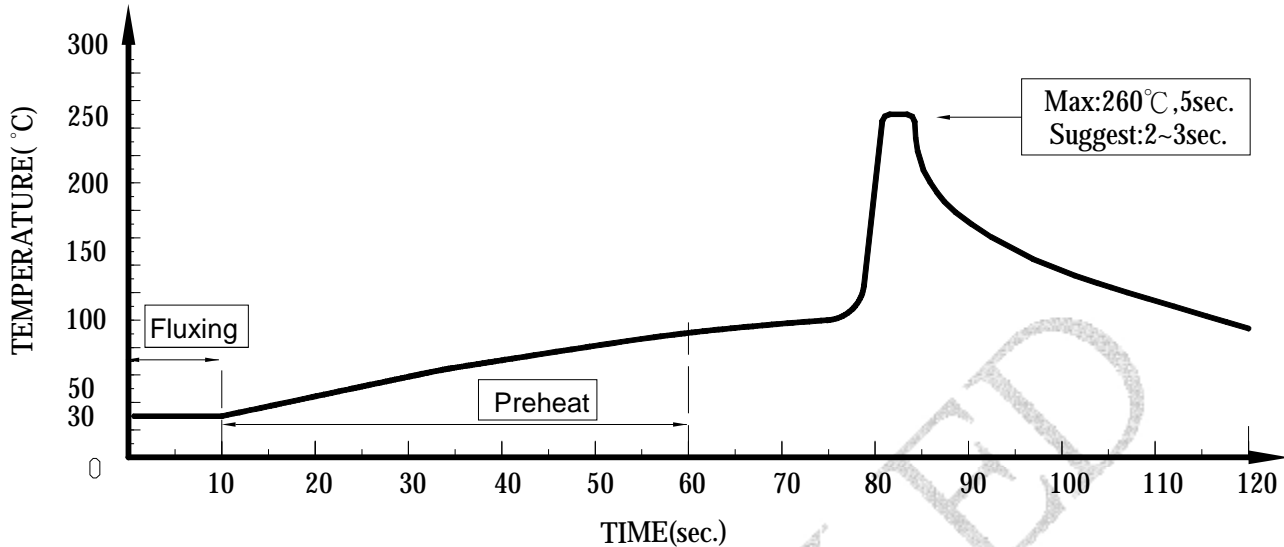

1. Please avoid any external stress applied to the lead-frames and epoxy while the LEDs are at high temperature, especially during soldering
2. DIP soldering and hand soldering should not be done more than one time.
3. After soldering, avoid the epoxy lens from mechanical shock or vibration until the LEDs are back to room temperature.
4. Avoid rapid cooling during temperature ramp-down process
5. Although the soldering condition is recommended above, soldering at the lowest possible temperature is feasible for the LEDs

## ● IRON Soldering

**A: Max: 350°C Within 3 sec. One time only.**

**B: The products of 3mm without flange, welding condition of flat plate PCB Max: 350°C Within 2 sec. One time only**

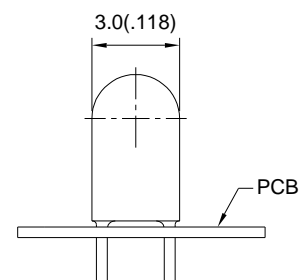

## I Tapping and packaging specifications(Units: mm)

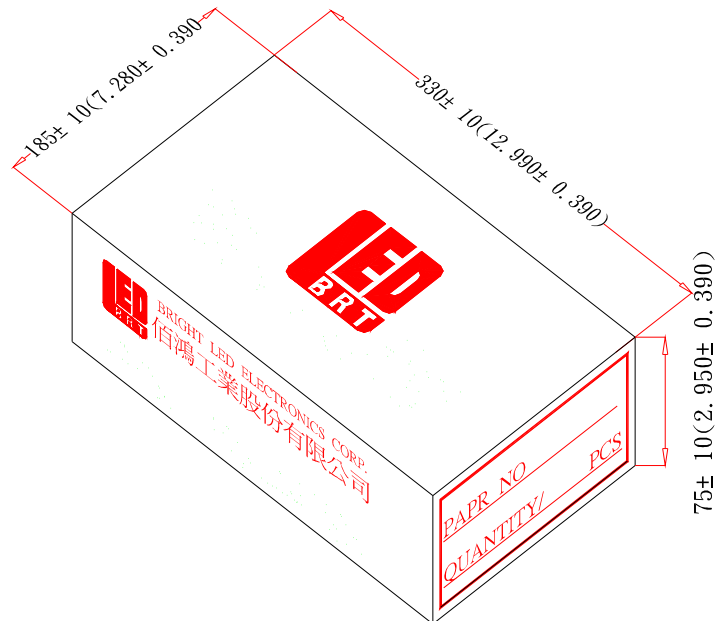

## I Packaging Bag Dimensions

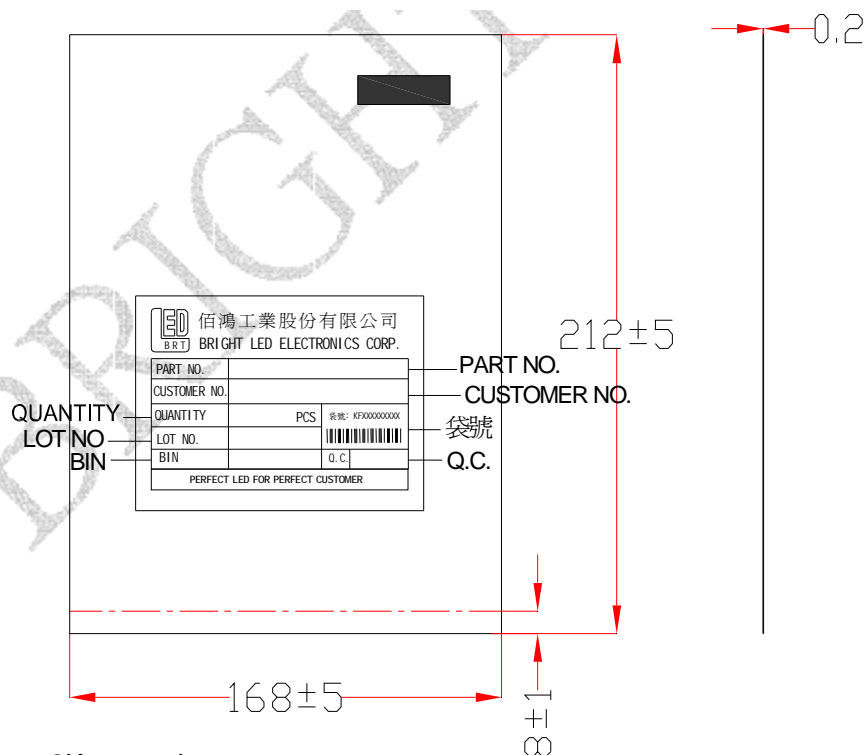

### Notes:

- 1、1000pcs per bag, 8Kpcs per box.
- 2、All dimensions are in millimeters(inches).
- 3、Specifications are subject to change without notice.



### Phototransistor Specification

2 Commodity: Phototransistor

2 Collector Current Bin Limits ( $V_R=5V$ ,  $E_e=1mW/cm^2$ )

BIN CODE	Min.( uA)	Max.(uA)
W	17.8	21.3
X	21.3	25.6
Y	25.6	30.8
Z	30.8	36.9
1	36.9	44.3
2	44.3	53.2

NOTES: Tolerance of measurement of Radiant Intensity :±15%

单击下面可查看定价，库存，交付和生命周期等信息

[>>BRT\(佰鸿工业\)](#)