

1. Key Features of CAP-XX Supercapacitors

- Thin, flat and small – ideal for space-constrained applications
- High power density (up to 90kW / litre) and high power output
- Ultra-low ESR (from 14mΩ), even at low temperatures (~2x nominal at -30°C)
- High energy density (up to 2.1Wh / litre) and cell voltage (up to 2.75V / cell)
- Wide operating temperature range (-40°C, up to +85°C)
- Very low leakage current (typically < 1µA after 120hrs)
- Long cycle life (exceeding 1 million cycles) and excellent frequency response
- Environmentally friendly: RoHS, WEEE and REACH compliant, Lead-free, Halogen-free and Conflict metal-free
- UL recognized and ISO 9001-2008 certified

2. Typical Applications of CAP-XX Supercapacitors

CAP-XX supercapacitors are ideally suited to provide:

- Peak power for pulsed loads - Extending battery run time and cycle life, especially when “old or cold”, and allowing the use of smaller and lower power batteries in high peak load applications such as RF transmissions, LED flash, GPS location, valve/lock actuation, screen refresh in OLED and ePPD displays, thermal printers, injection and inhalation systems, etc.
- Backup power for mission-critical applications - Providing maintenance-free continuous power, through outages and fluctuations, such as SSD cache protection and write speed optimization, last gasp transmissions from WSNs, drop-test protection, graceful shutdown and battery hot swap in industrial handheld devices, and safety valve/lock actuation to failsafe mode – even at low temperatures.
- Stored energy for low/variable power sources - Offering an environmentally friendly and maintenance-free alternative to batteries, for systems powered by ambient energy harvesters, as well as enabling quick charge at high energy via cable, cradle or induction, to shorten charge time and maximize operating time and process speed.

3. CAP-XX Product Range

CAP-XX supercapacitors are available as dual cell modules - ideal for use with Li-ion rechargeable batteries and USB power supplies - or in a single cell configuration, offering ultra-thin design options for space-constrained applications.

Four footprints are currently available:

- “A” (20.0mm x 18.0mm)
- “B” (20.5mm x 18.5mm)
- “W” (28.5mm x 17.0mm)
- “S” (39.0mm x 17.0mm)

Note that the “Z” footprint (20.0 x 15.0mm) is currently available only to order, and will be discontinued in 2013 (contact CAP-XX for more information).

“S”, “W”, “A” and “Z” series products have an external package made of aluminium. “B” series products are packaged in stainless steel.



G Series Product Specifications

4. G Series Product Specifications

Dual cell modules					
Product Name ¹	CAP ² (± 20%) ³	ESR ² (± 20%) ³	Thickness (max)	Body Size (mm)	Voltage & Temperature
GA209F	80 mF	130 mΩ	2.20 mm	20.0 x 18.0	4.5V_{nominal} 5.0V_{peak} -40°C to +70°C T_{max} = 70°C
GB230F	350 mF	60 mΩ	3.10 mm	20.5 x 18.5	
GW209F	140 mF	70 mΩ	2.20 mm	28.5 x 17.0	
GW202F	220 mF	50 mΩ	3.00 mm		
GW201F	350 mF	70 mΩ	2.50 mm		
GW203F	550 mF	50 mΩ	3.50 mm		
GS203F	250 mF	45 mΩ	2.20 mm	39.0 x 17.0	
GS206F	600 mF	40 mΩ	2.50 mm		
GS208F	900 mF	28 mΩ	3.50 mm		
GS230F	1200 mF	28 mΩ	3.80 mm		
GZ215F	75 mF	150 mΩ	2.50 mm	20.0 x 15.0	
GW207F	450 mF	55 mΩ	3.00 mm	28.5 x 17.0	

Parameter	Name	Condition	Minimum	Nominal	Maximum
Leakage Current ⁴	I _L	23°C		1μA	2μA
RMS Current	I _{RMS}	23°C			4A – 7A
Pulse Current ⁵	I _{peak}				30A
ESR change with Temperature		Min @ +70°C Max @ -40°C	75% of nominal		200% of nominal

Notes

- Bold products are Standard. GZ215, GW207, GS211 and all single cell devices are available on a "build to order" basis. Special terms and conditions of sale apply (MOQ, L/T, NCNR, etc.). Contact CAP-XX for more information.
- Capacitance will decline and ESR will rise over time, at a rate which depends on temperature and voltage. Operation at concurrent high temperature & voltage is not recommended for extended periods. See Section 6 for more information.
- DC capacitance and ESR tolerance are measured at +23°C.
- Leakage current is measured after 120hrs at nominal voltage and +23°C.
- Single pulse, non-repetitive current (positive & negative terminal short-circuited)

CAP-XX Supercapacitors - Product Guide 2013



H Series Product Specifications

5. H Series Product Specifications

Dual cell modules					
Product Name ¹	CAP ² (± 20%) ³	ESR ² (± 20%) ³	Thickness (max)	Body Size (mm)	Voltage & Temperature
HA202F	120 mF	140 mΩ	3.00 mm	20.0 x 18.0	5.5V _{nominal} 5.8V _{peak} -40°C to +70°C T _{max} = 85°C
HA230F	400 mF	140 mΩ	3.80 mm		
HW209F	140 mF	120 mΩ	2.20 mm	28.5 x 17.0	
HW202F	220 mF	90 mΩ	3.00 mm		
HW201F	350 mF	120 mΩ	2.50 mm		
HW203F	550 mF	90 mΩ	3.50 mm		
HS203F	250 mF	75 mΩ	2.20 mm	39.0 x 17.0	
HS206F	600 mF	70 mΩ	2.50 mm		
HS208F	900 mF	50 mΩ	3.50 mm		
HS230F	1200 mF	50 mΩ	3.80 mm		
HZ202F	90 mF	200 mΩ	3.00 mm	20.0 x 15.0	

Parameter	Name	Condition	Minimum	Nominal	Maximum
Leakage Current ⁴	I _L	23°C		1μA	2μA
RMS Current	I _{RMS}	23°C			5A – 10A
Pulse Current ⁵	I _{peak}				30A
ESR change with Temperature		Min @ +70°C Max @ -40°C	75% of nominal		350% of nominal

Notes

1. Bold products are Standard. HZ202, HW207, HS211 and all single cell devices are available on a "build to order" basis. Special terms and conditions of sale apply (MOQ, L/T, NCNR, etc.). Contact CAP-XX for more information.
2. Capacitance will decline and ESR will rise over time, at a rate which depends on temperature and voltage. Operation at concurrent high temperature & voltage is not recommended for extended periods. See Section 6 for more information.
3. DC capacitance and ESR tolerance are measured at +23°C.
4. Leakage current is measured after 120hrs at nominal voltage and +23°C.
5. Single pulse, non-repetitive current (positive & negative terminal short-circuited).

CAP-XX Supercapacitors - Product Guide 2013

6. Storage & Operation Metrics

Parameter	Condition	Metric	G Series	H Series	Notes
Operating temperature	Maximum operating temperature	T_{max} (°C)	+70°C	+85°C	Brief excursions to T_{max} will not damage the device.
	Continuous operating temperature range	T_{cont} (°C)	-40°C to +70°C	-40°C to +70°C	Continuous operation at T_{max} is not recommended. See data on load life for more.
Shelf life	Recommended maximum storage temperature & humidity	T_{shelf} (°C)	-40°C to +35°C	-40°C to +35°C	Store in original packaging in an air conditioned room.
		RH_{shelf} (%)	< 60%	< 60%	Storage at high temperature is not recommended.
	2 years @ $T_{shelfmax}$	C loss (% of initial C)	< 10%	< 20%	Storage at high humidity is not recommended.
		ESR rise (% of initial ESR)	< 20%	< 40%	
	10 years @ 23°C	C loss (% of initial C)	< 20%	< 20%	
		ESR rise (% of initial ESR)	< 50%	< 100%	
Cycle life	500,000 cycles @ 23°C ($V_n \rightarrow \frac{1}{2}V_n, I = 0.5A$)	C loss (% of initial C)	< 1%	< 5%	Voltage cycling at low RMS current will not affect life. Cycling at high RMS current will cause self-heating, which will in turn affect life. See Technical Guide.
		ESR rise (% of initial ESR)	< 1%	< 5%	
Load life	@ V_n & 23°C G series = 4.5V, 23°C H Series = 5.5V, 23°C	C loss rate (% / 1000h)	< 1%	< 3%	C loss rates & ESR rise rates are drawn from long term life tests, conducted over periods at least 12 months.
		ESR rise rate (% of initial / 1000h)	< 1%	< 3%	
	@ 80% V_n & 80% T_{cont} G series = 3.6V, 50°C H Series = 4.5V, 50°C	C loss rate (% / 1000h)	< 2%	< 6%	ESR rise rate is linear.
		ESR rise rate (% of initial / 1000h)	< 4%	< 9%	C loss follows an exponential decay.
	@ V_n & T_{cont} G series = 4.5V, 70°C H Series = 5.5V, 70°C	C loss rate (% / 1000h)	< 10%	< 15%	
		ESR rise rate (% of initial / 1000h)	< 15%	< 45%	
MTTF	@ V_n & 23°C G series = 4.5V, 23°C H Series = 5.5V, 23°C	MTTF (years)	> 10	> 10	MTTF is calculated with a regression equation (Arrhenius form) from observed failures during long term life testing.
	@ 80% V_n & 80% T_{cont} G series = 3.6V, 50°C H Series = 4.5V, 50°C	MTTF (years)	3	2	Note that such calculations are inaccurate at low temperatures due to low/no observed failures.
	@ V_n & T_{cont} G series = 4.5V, 70°C H Series = 5.5V, 70°C	MTTF (years)	< 1	< 1	

20. Product Drawings: Dual Cell Modules

GS2 & HS2 Mechanical & Electrical Drawing

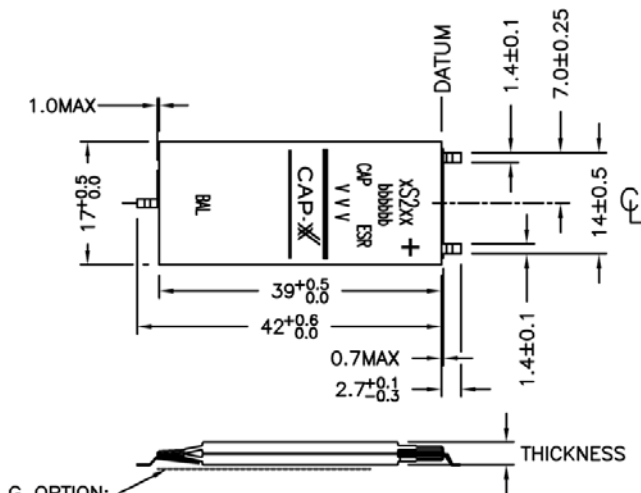

G OPTION:
TAPE ON UNDERSIDE ADDS 0.1mm
TO DEVICE THICKNESS WITHOUT RELEASE TAPE

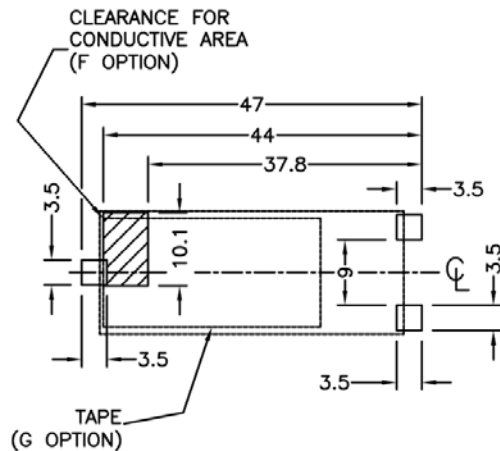
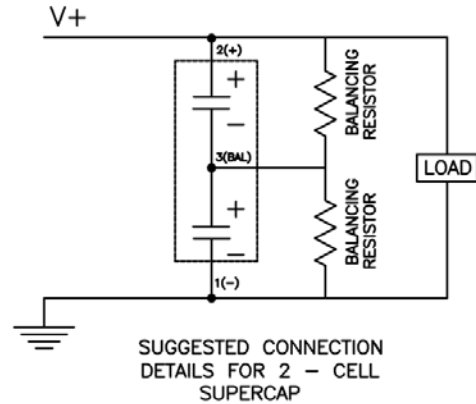
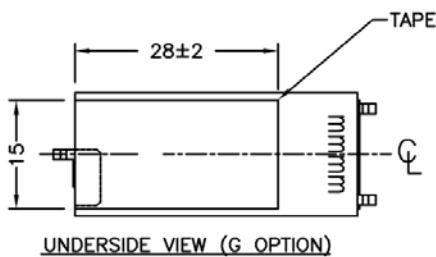
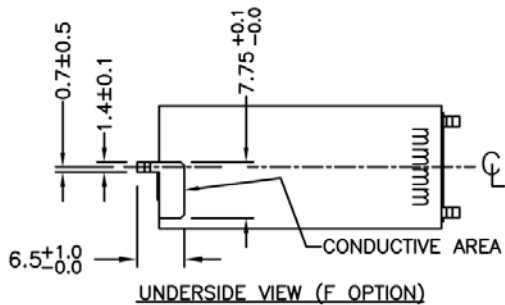

SUGGESTED PAD LAYOUT
CUSTOMERS SHOULD DETERMINE
FINAL PAD SIZE AND PLACEMENT
BASED ON THEIR
MANUFACTURING TOLERANCES

GW2 & HW2 Mechanical & Electrical Drawing

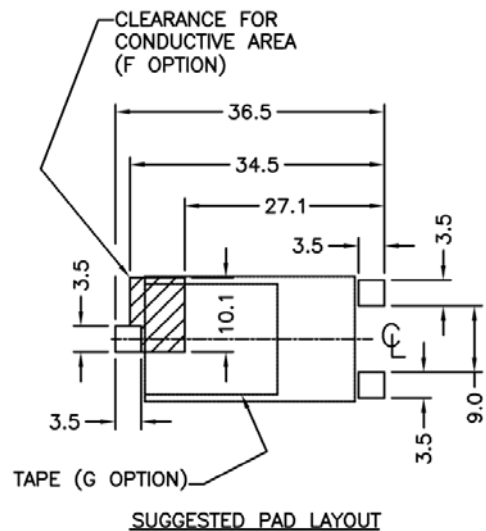
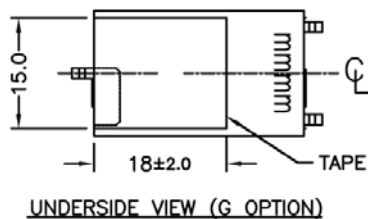
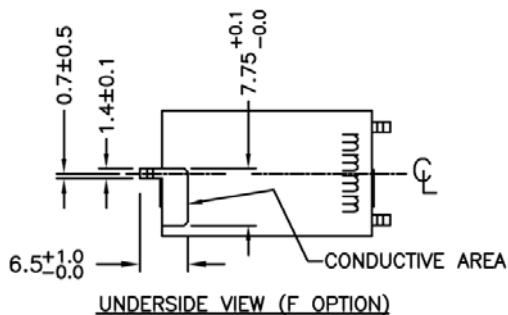
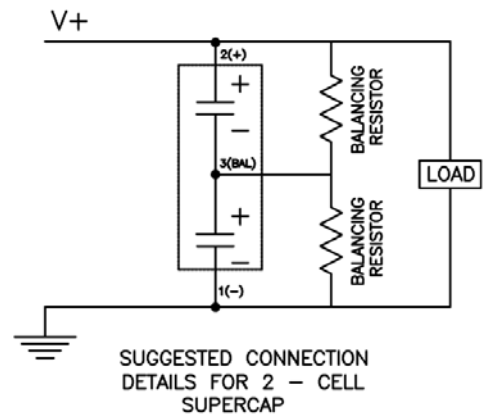
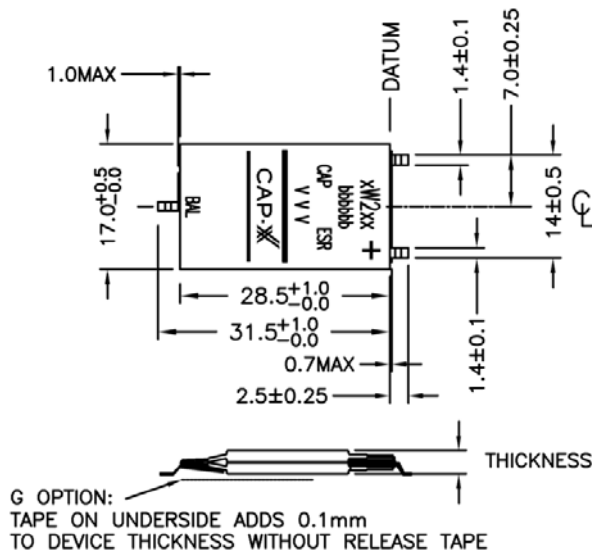

CUSTOMERS SHOULD DETERMINE
 FINAL PAD SIZE AND PLACEMENT
 BASED ON THEIR
 MANUFACTURING TOLERANCES

HA2 Mechanical & Electrical Drawing

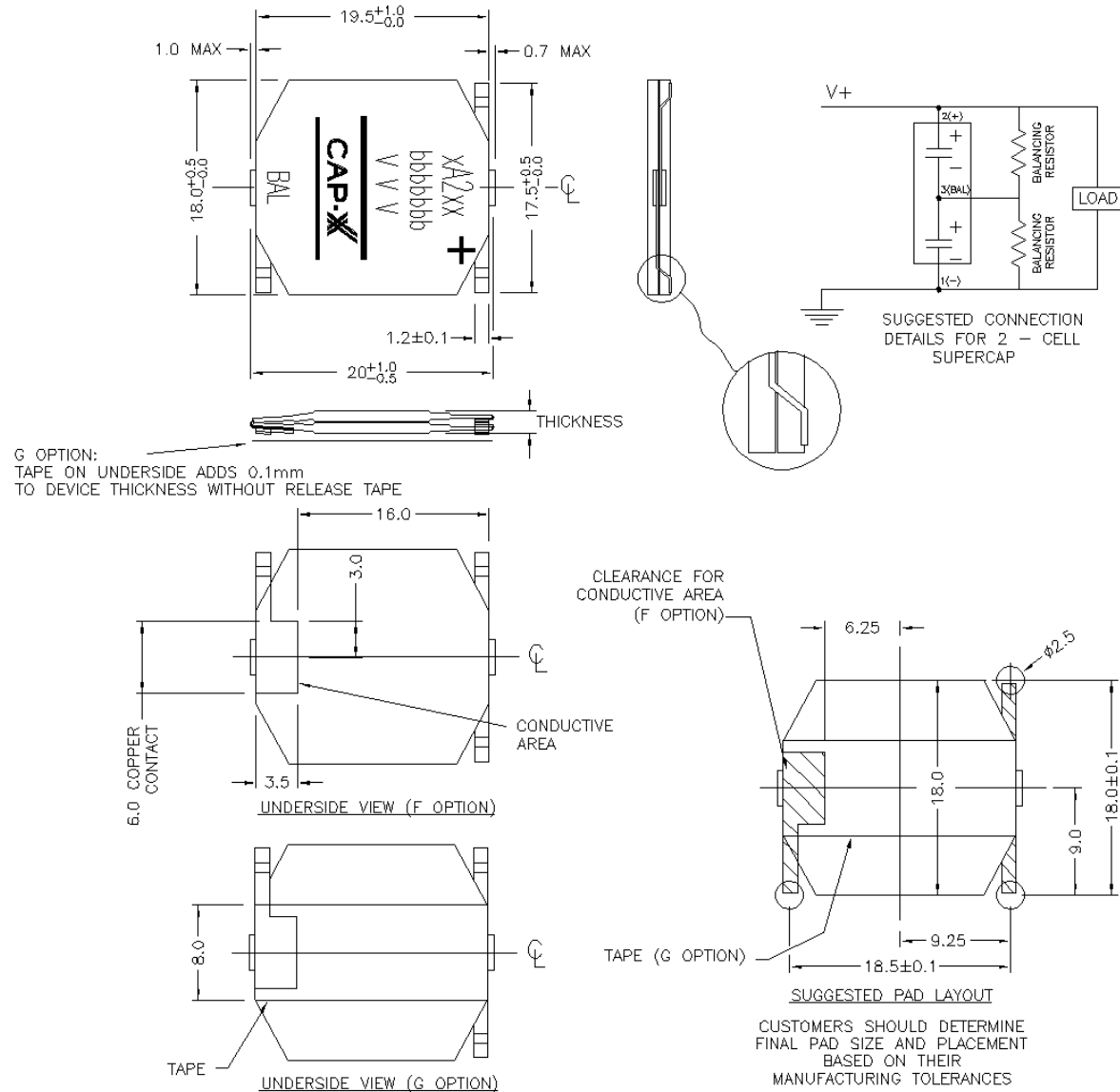

GB2 Mechanical & Electrical Drawing

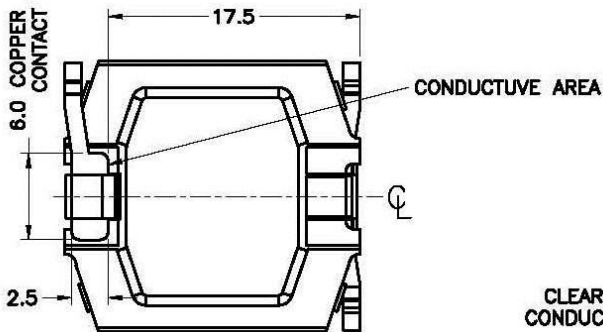
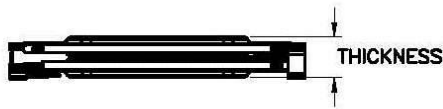
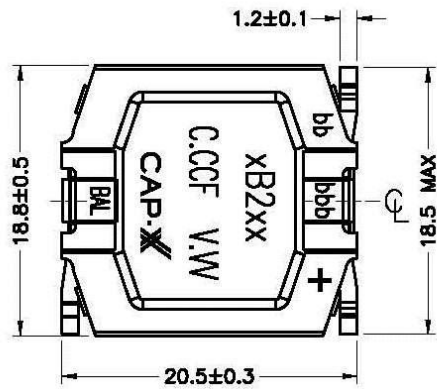

UNDERSIDE VIEW

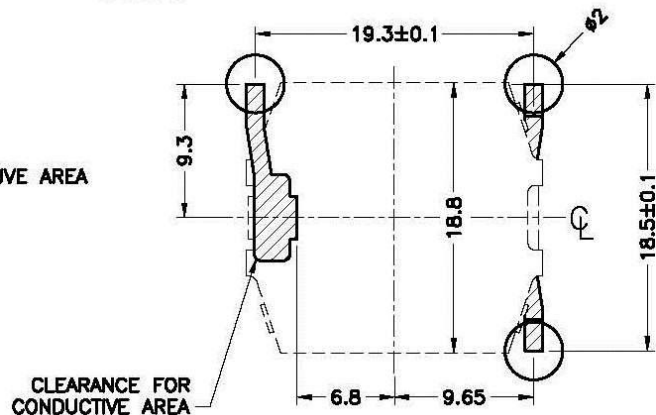
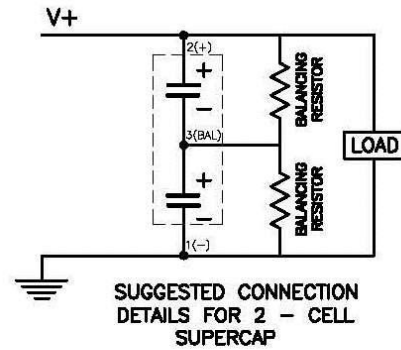
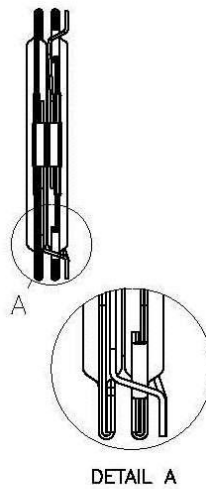

SUGGESTED PAD LAYOUT

CUSTOMERS SHOULD DETERMINE
FINAL PAD SIZE AND PLACEMENT
BASED ON THEIR
MANUFACTURING TOLERANCES

GZ2 & HZ2 Mechanical & Electrical Drawing

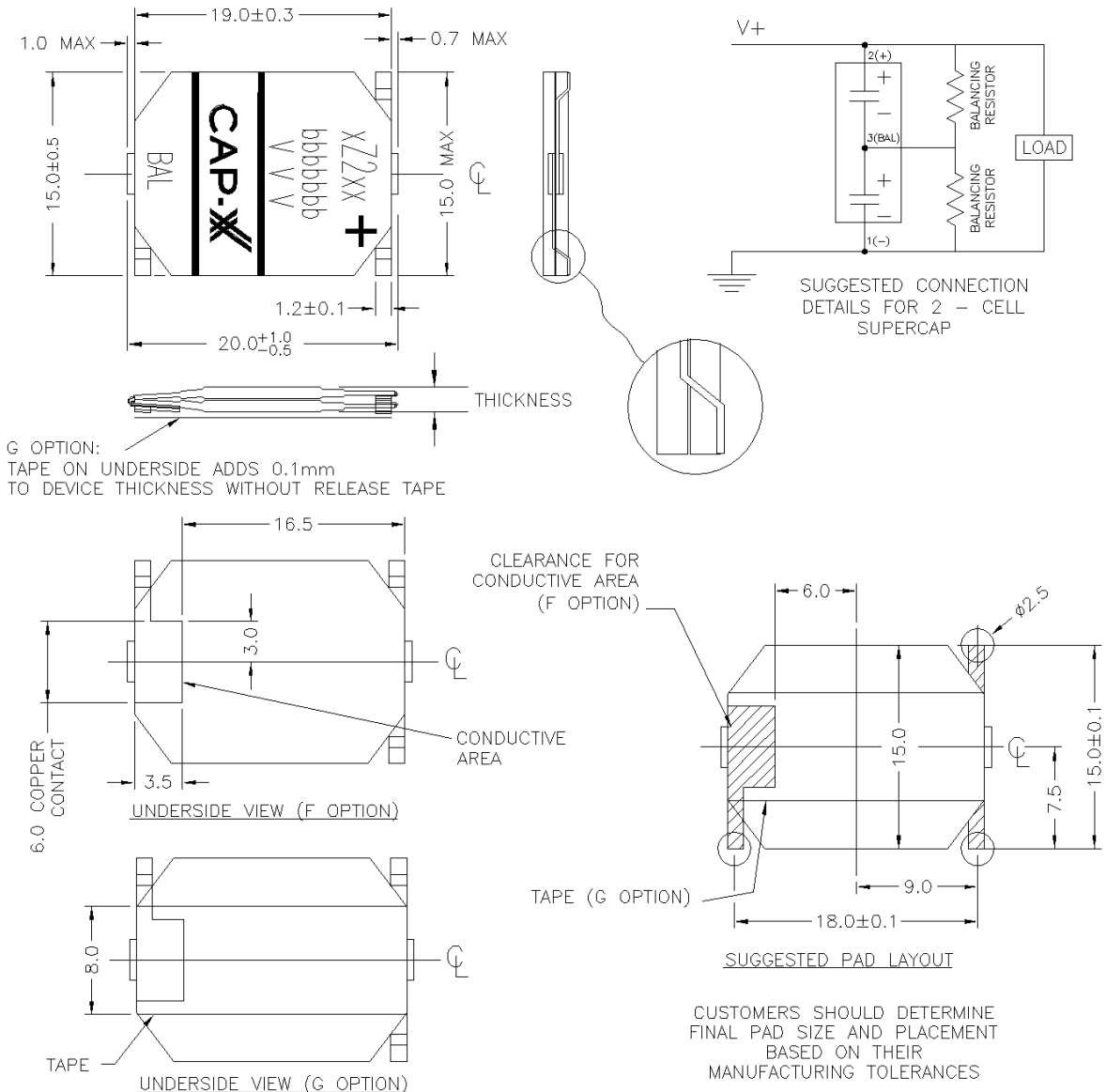

单击下面可查看定价，库存，交付和生命周期等信息

[>>CAP-XX](#)