

To.

DATE : 20 . . .

|      |              |
|------|--------------|
| RoHS | Halogen Free |
|------|--------------|

# SPECIFICATION

PRODUCT : STARCAP

MODEL : DCL Series

| WRITTEN | CHECKED | APPROVED |
|---------|---------|----------|
|         |         |          |

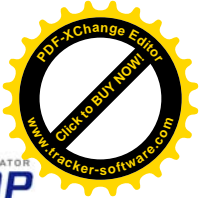
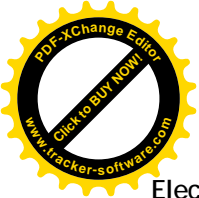

# Index

| Page No. | ITEM                                   | etc. |
|----------|--|------|
| 1        | Cover Page                             |      |
| 2        | Index                                  |      |
| 3        | Revision History                       |      |
|          | Manufacturer Information               |      |
| 4        | 1. Scope                               |      |
|          | 2. Part Number System                  |      |
|          | 3. Photo                               |      |
|          | 4. General Specifications              |      |
| 5-7      | 5. Product Construction and Dimension  |      |
| 8        | 6. Reliability Specifications          |      |
| 9        | 7. Packing Specifications              |      |
|          | 8. Labeling Standards                  |      |
| 10       | 9. Measuring Method of Characteristics |      |
| 11       | 10. Mounting                           |      |
| 12-13    | 11. Cautions for Use                   |      |
| 14       | 12. Environmental Management           |      |
|          |  |      |
|          |  |      |
|          |  |      |
|          |  |      |
|          |  |      |
|          |  |      |
|          |  |      |



### 1. Scope

This specification applies to STARCAP(Electric Double Layer Capacitor), submitted to specified customer in cover page.

### 2. Part Number System

DCL 5R5 105 V F (Example)  
 ① ② ③ ④ ⑤

- ① Series Name
- ② Rated Voltage : 5.5VDC
- ③ Capacitance : 1.0 F (105 =  $10 \times 10^{+5}$  uF)
- ④ Terminal Type : V-type
- ⑤ Pb-Free

### 3. Photo



**V-TYPE**



**H-TYPE**



**C-TYPE**

(Example)

### 4. General Specifications

| ITEMS                              | DCL5R5105       | DCL5R5155       |
|------------------------------------|-----------------|-----------------|
| Rated Voltage                      | 5.5 VDC         | 5.5 VDC         |
| Operating Temp.                    | -25 ~ +70 °C    | -25 ~ +70 °C    |
| Capacitance                        | 1.0 F           | 1.5 F           |
| Capacitance Tolerance              | -20 ~ 80 %      | -20 ~ 80 %      |
| Equivalent Series Resistance (ESR) | Less than 30Ω   | Less than 30Ω   |
| Leakage Current (LC, 30min.)       | Less than 1.5mA | Less than 1.5mA |

### 5. Product Construction and Dimension (V-type)

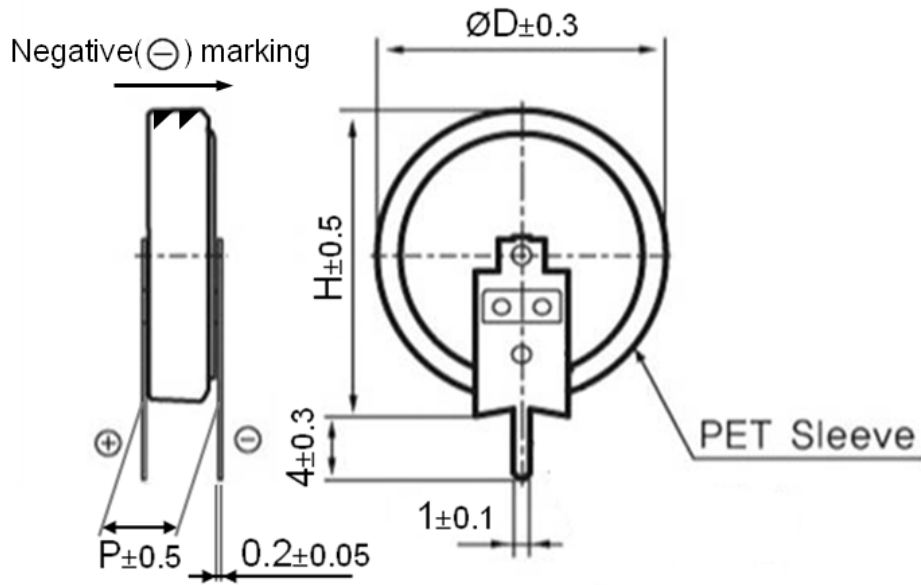

| Part No.    | Dimensions (mm) |      |     |
|-------------|-----------------|------|-----|
|             | ØD              | H    | P   |
| DCL5R5105VF | 19.0            | 19.5 | 5.0 |
| DCL5R5155VF | 19.0            | 19.5 | 5.0 |

### 5. Product Construction and Dimension (H-type)

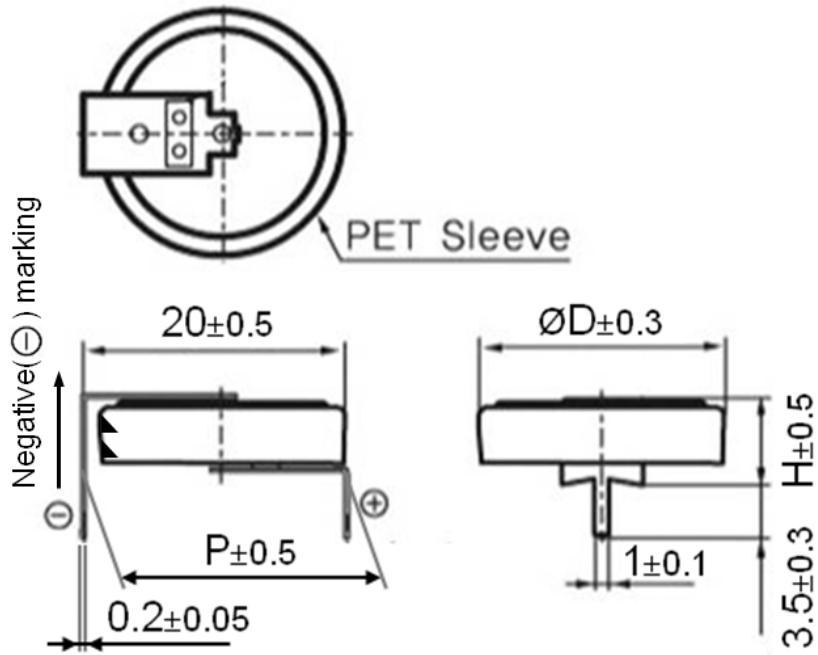

| Part No.    | Dimensions (mm) |     |      |
|-------------|-----------------|-----|------|
|             | ØD              | H   | P    |
| DCL5R5105HF | 19.0            | 6.5 | 20.0 |
| DCL5R5155HF | 19.0            | 6.5 | 20.0 |

### 5. Product Construction and Dimension (C-type)

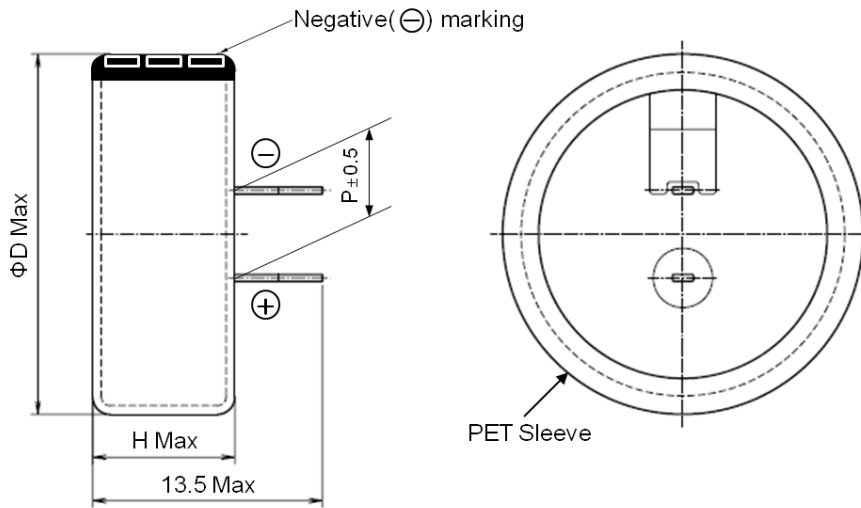

*\* There is no plating on the cut surface*

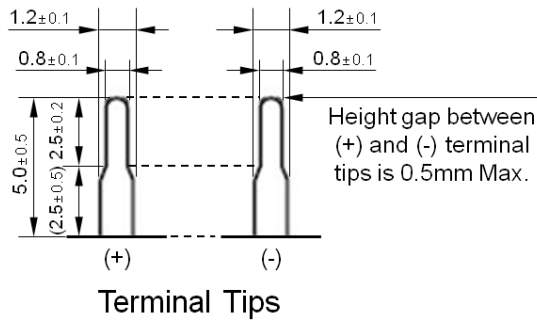

| Part No.    | Dimensions (mm) |     |     |
|-------------|-----------------|-----|-----|
|             | ØD              | H   | P   |
| DCL5R5105CF | 21.5            | 7.5 | 5.0 |
| DCL5R5155CF | 21.5            | 7.5 | 5.0 |

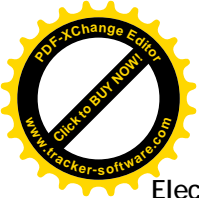

### 6. Reliability Specifications

| Item                           |                                   | Specification                     |                               | Test Condition (JISC5102)  |  |      |             |   |        |   |         |   |        |   |        |   |        |
|--------------------------------|-----------------------------------|-----------------------------------|-------------------------------|--|--|------|-------------|---|--------|---|---------|---|--------|---|--------|---|--------|
| Temperature Characteristics    | Capacitance Change                | Step 2                            | Within ± 30% of Initial Value | Measure electrical characteristics after exposing STARCAP Capacitor to each temperature atmosphere for one(1) hour<br><br><table border="1"> <thead> <tr> <th>Step</th> <th>Temperature</th> </tr> </thead> <tbody> <tr> <td>1</td> <td>20±2°C</td> </tr> <tr> <td>2</td> <td>-25±2°C</td> </tr> <tr> <td>3</td> <td>20±2°C</td> </tr> <tr> <td>4</td> <td>70±2°C</td> </tr> <tr> <td>5</td> <td>20±2°C</td> </tr> </tbody> </table> |  | Step | Temperature | 1 | 20±2°C | 2 | -25±2°C | 3 | 20±2°C | 4 | 70±2°C | 5 | 20±2°C |
|                                | Step                              |                                   | Temperature                   |  |  |      |             |   |        |   |         |   |        |   |        |   |        |
|                                | 1                                 | 20±2°C                            |                               |  |  |      |             |   |        |   |         |   |        |   |        |   |        |
|                                | 2                                 | -25±2°C                           |                               |  |  |      |             |   |        |   |         |   |        |   |        |   |        |
|                                | 3                                 | 20±2°C                            |                               |  |  |      |             |   |        |   |         |   |        |   |        |   |        |
|                                | 4                                 | 70±2°C                            |                               |  |  |      |             |   |        |   |         |   |        |   |        |   |        |
|                                | 5                                 | 20±2°C                            |                               |  |  |      |             |   |        |   |         |   |        |   |        |   |        |
| ESR                            | 5Times or less than Initial Value |                                   |                               |  |  |      |             |   |        |   |         |   |        |   |        |   |        |
| Capacitance Change             | Step 4                            | Within ± 30% of Initial Value     |                               |  |  |      |             |   |        |   |         |   |        |   |        |   |        |
| ESR                            |                                   | 4Times or less than Initial Value |                               |  |  |      |             |   |        |   |         |   |        |   |        |   |        |
| LC(30min.)                     |                                   | 4Times or less than Initial Value |                               |  |  |      |             |   |        |   |         |   |        |   |        |   |        |
| Capacitance Change             | Step 5                            | Within ± 10% of Initial Value     |                               |  |  |      |             |   |        |   |         |   |        |   |        |   |        |
| ESR Change                     |                                   | Within ± 10% of Initial Value     |                               |  |  |      |             |   |        |   |         |   |        |   |        |   |        |
| LC Change (30min.)             |                                   | Within ± 10% of Initial Value     |                               |  |  |      |             |   |        |   |         |   |        |   |        |   |        |
| Humidity Resistance            | Capacitance Change                | ± 30% of Initial Value            |                               | Temp. : 40±2°C<br>Humidity : 90 ~ 95%RH<br>Time : 240±8 Hours<br><b>No Voltage Applied</b>   |  |      |             |   |        |   |         |   |        |   |        |   |        |
|                                | ESR                               | 3Times or less than Spec. Value   |                               |  |  |      |             |   |        |   |         |   |        |   |        |   |        |
|                                | LC(30min.)                        | 2Times or less than Spec. Value   |                               |  |  |      |             |   |        |   |         |   |        |   |        |   |        |
|                                | Appearance                        | No Marked Defect                  |                               |  |  |      |             |   |        |   |         |   |        |   |        |   |        |
| Self Discharge Characteristics | Voltage                           | More than 4.2Vdc                  | Charging Condition            | Voltage : 5.5Vdc<br>Current : 50mA<br>Charge Time : 24 Hours   |  |      |             |   |        |   |         |   |        |   |        |   |        |
|                                |                                   |                                   | Self Discharge Condition      | Duration : 24 Hours<br>Temp. : Less than 25°C<br>Humidity : Less than 70%RH  |  |      |             |   |        |   |         |   |        |   |        |   |        |
| Vibration Resistance           | Capacitance                       | Spec. Value                       |                               | Amplitude : 1.5mm<br>Frequency : 10 ~ 55Hz<br>Direction : X, Y, Z 3 Directions<br>Test Time : 6 Hours  |  |      |             |   |        |   |         |   |        |   |        |   |        |
|                                | ESR                               | Spec. Value                       |                               |  |  |      |             |   |        |   |         |   |        |   |        |   |        |
|                                | LC(30min.)                        | Spec. Value                       |                               |  |  |      |             |   |        |   |         |   |        |   |        |   |        |
|                                | Appearance                        | No Marked Defect                  |                               |  |  |      |             |   |        |   |         |   |        |   |        |   |        |
| Terminal Strength              | Appearance                        | Terminals shall not be separated  |                               | Load 1kg , 10±1 Sec.   |  |      |             |   |        |   |         |   |        |   |        |   |        |
| Terminal Bend Strength         |                                   |                                   |                               | Load 1kg , Angle 90° , 1Cycle  |  |      |             |   |        |   |         |   |        |   |        |   |        |
| Endurance                      | Capacitance Change                | Within ± 30% of Initial Value     |                               | Temp. : 70±2°C<br>Test Time : 1,000(+24,-0) Hours<br>Applied Voltage : 5.5Vdc  |  |      |             |   |        |   |         |   |        |   |        |   |        |
|                                | ESR                               | 4Times or less than Initial Value |                               |  |  |      |             |   |        |   |         |   |        |   |        |   |        |
|                                | LC(30min.)                        | Spec. Value                       |                               |  |  |      |             |   |        |   |         |   |        |   |        |   |        |
|                                | Appearance                        | No Marked Defect                  |                               |  |  |      |             |   |        |   |         |   |        |   |        |   |        |
| Cycle Characteristics          | Capacitance Change                | Within ± 30% of Initial Value     |                               | Temp. : 25±2°C<br>Cycle No. : 10,000<br>Charge Voltage : 5.5Vdc<br>Resistance : 100Ω, Time : 9min.<br>Discharge Resistance:100Ω, Time:1min.  |  |      |             |   |        |   |         |   |        |   |        |   |        |
|                                | ESR                               | 4Times or less than Initial Value |                               |  |  |      |             |   |        |   |         |   |        |   |        |   |        |
|                                | LC(30min.)                        | Spec. Value                       |                               |  |  |      |             |   |        |   |         |   |        |   |        |   |        |
|                                | Appearance                        | No Marked Defect                  |                               |  |  |      |             |   |        |   |         |   |        |   |        |   |        |



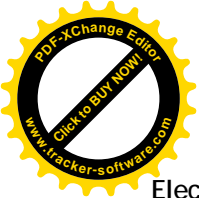

### 7. Packing Specification

| Part No.         | Quantity (PCS) |           |           | Size (W × L × H mm) |             | Type |
|------------------|----------------|-----------|-----------|---------------------|-------------|------|
|                  | Tray           | Inner Box | Outer Box | Inner Box           | Outer Box   |      |
| DCL5R5105(V,H,C) | 50             | 350       | 700       | 295×230×140         | 485×305×150 | Tray |
| DCL5R5155(V,H,C) | 50             | 350       | 700       | 295×230×140         | 485×305×150 | Tray |

### 8. Labeling Standards

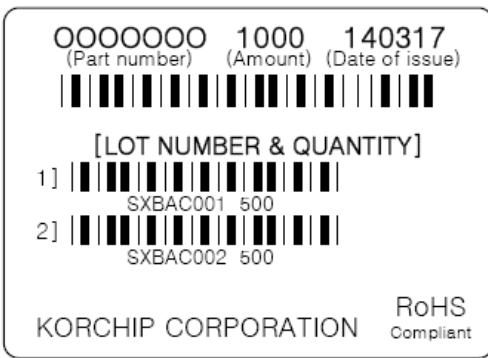

← (Example)

#### Lot No. System

Ex.) S C X A C 002

① ② ③ ④ ⑤ ⑥

- ① Product Code : S (STARCAP)
- ② Production Year Code : A (2016), B (2017), C (2018), D (2019)...
- ③ Factory Identification Code : X (Factory X)
- ④ Production Month Code : A (Jan.), B (Feb.), ... , J (Oct.), K (Nov.), L (Dec.)
- ⑤ Production Date Code : 1 (1st), 2 (2nd), ... , 9 (9th), A (10th), B (11th), C (12th) ...  
 Q (26th), R (27th), S (28th), ... , V (31th)
- ⑥ Lot Issuing Serial Code : 001 (First lot of a specific day), 002 (Second lot of a specific day), 003 (Third lot of a specific day)...

### 9. Measuring Method of Characteristics

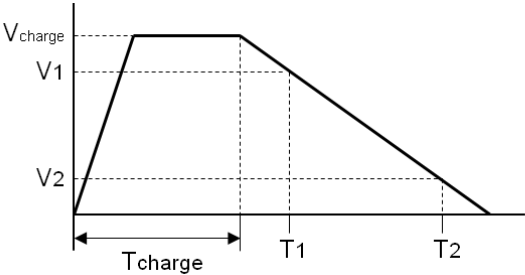
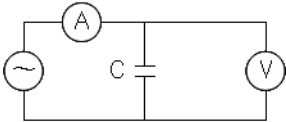
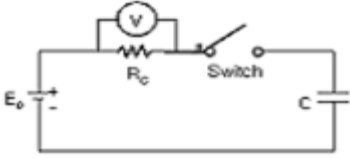
|   |  |
|---|--|
| <p>Capacitance</p>  | <ol style="list-style-type: none"> <li>1) Charge the STARCAP with constant current <math>I_{charge}(=0.05A)</math> to <math>V_{charge}(=5.0V)</math> then keep charging for <math>T_{charge}(=1800sec.)</math></li> <li>2) Discharge the STARCAP with constant current <math>I_{disch}(=0.003A)</math> while measure the discharge time <math>T_1, T_2</math> between <math>V_1(=4.4V)</math> and <math>V_2(=2.2V)</math>.</li> <li>3) Calculate capacitance using the following formula.</li> </ol>  $C = \frac{I_{disch} \times (T_1 - T_2)}{V_1 - V_2}$ |
| <p>Equivalent Series Resistance (ESR @1kHz)</p>   | <ul style="list-style-type: none"> <li>● Measure ESR by the LCR meter. (Frequency:1kHz, Bias Voltage : <math>0^{+0.05}V</math>) or</li> <li>● Calculate ESR using the following formula.</li> </ul>  $R[\Omega] = V[V] / I[A] \quad * i [mA] = I[A] \times 10^{-3}$ <p> <math>R</math> : Internal resistance(ESR) [<math>\Omega</math>]<br/> <math>V</math> : Measured voltage between terminals [V]<br/> <math>i</math> : Current 1mA(A.C.)         </p> $ESR[\Omega] = V / i$   |
| <p>Leakage Current</p>  | <ol style="list-style-type: none"> <li>1) Apply <math>5.5 \pm 0.1V</math> to the STARCAP.(<math>E_0</math>)</li> <li>2) Measure <math>V_R</math> after <math>30 \pm 0.5</math> min.</li> <li>3) Calculate current using the following formula.</li> </ol>  $LC = (V_R/R_C) \times 10^3 [mA]$ <p> <math>V_R</math> = Measured value<br/> <math>R_C = 100\Omega</math> (0.47F)<br/> <math>1000\Omega</math> (1F, 1.5F)         </p>   |
| <p>☞ The STARCAP should be shorted before each measurement as follows ;<br/>             Capacitance : 60 min. , ESR : 15 min. , LC : 15 min.</p> |  |

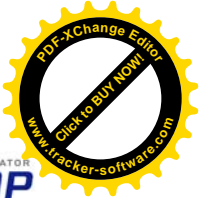
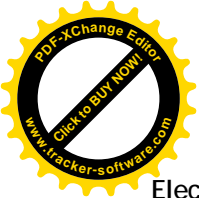

### 10. Mounting

When you solder STARCAP to a printed circuit board, excessive thermal stress could cause the STARCAP's electrical characteristics to deteriorate, compromise the integrity of the seal or cause the electrolyte to leak due to increased internal pressure.

#### ① Recommended condition of flow soldering

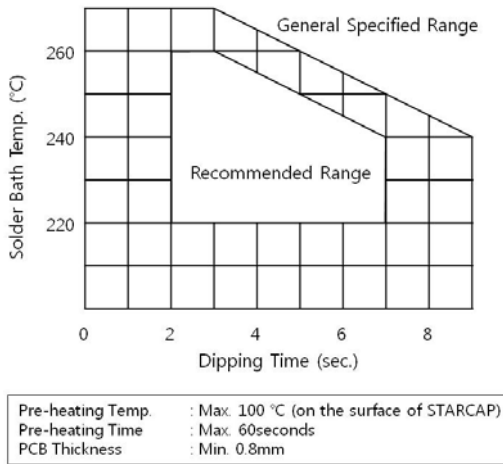

#### ② Recommended condition of manual soldering

- Soldering Tip Temp. : 350°C or less
- Soldering Time : 3 sec. or less
- Times : Three times or less at intervals of 9 sec. or more
- ※ Do not touch the metal case of STARCAP with a soldering iron.

③ It is not allowed to go through reflow (IR, Atmosphere heating methods etc.) process.

④ The terminals are plated for good solderability. Rasping terminals may damage the plating layer and degrade the solderability.

Do not apply a large force to the terminals. Otherwise, they may break or come off or the STARCAP characteristics may be deteriorated.

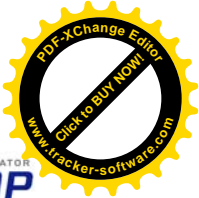
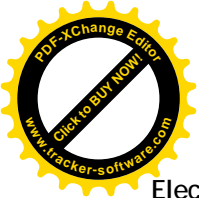

### 11. Cautions for Use

Please be careful for following points when you use STARCAP.

1) Do not apply more than rated voltage.

If you apply more than rated voltage, STARCAP's electrolyte will be decomposed and its ESR increase. At the worst, it may be broken.

2) Do not use STARCAP for ripple absorption.

3) Polarity

Please mount it in accordance with its polarity.

4) Operating temperature and life

Generally, STARCAP has a lower leakage current, longer back-up time and longer life in the low temperature i.e. the room temperature. But it has a higher leakage current, shorter back-up time and shorter life in the high temperature.

Please design to keep STARCAP away from calorific parts.

5) Humid Environment

Operation in high humid environment above 60%RH accelerate the degradation of STARCAP and may cause electrolyte leakage. If the product is supposed to be used in highly humid environment, please consult us.

6) Cleaning

Some detergent or high temperature drying causes deterioration of STARCAP. If you wash STARCAP, Consult us.

7) Following figure shows the general back-up circuit.

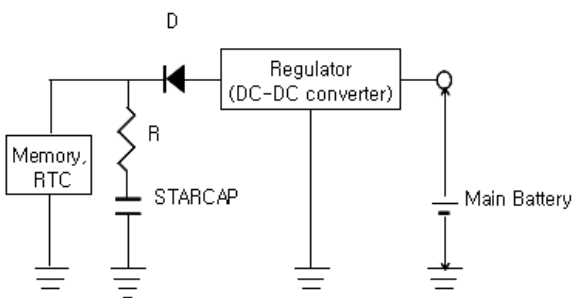

D : Diode to prevent the reverse current  
R : Resistor to control the charging current

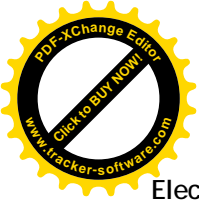

8) Short-circuit STARCAP

DO NOT short-circuit between terminals of STARCAP without resistor.

9) Storage

In long term storage, please store STARCAP in following condition;

- ① TEMP. : 15 ~ 35 °C
- ② HUMIDITY : 45 ~ 75 %RH
- ③ Non-dust, non-acidic and/or non-alkaline atmosphere
- ④ Avoid direct sun light, strong magnetic field

Storage period limit is one(1) year when a STARCAP is stored in the above condition. Storage in improper condition may cause some damage on terminal surface or on outer tube of STARCAP.

10) Do not disassemble STARCAP. It contains electrolyte.

11) Series connection of STARCAP

Over-rated voltage may be applied to a single STARCAP in series connection due to the deviation of capacitance and ESR of each STARCAP. Please inform us if you are using STARCAP in series connection and please design so as not to apply over-rated voltage to each STARCAP, and use STARCAPs from same lot.

12) The tips of STARCAP terminals are very sharp. Please handle with care.

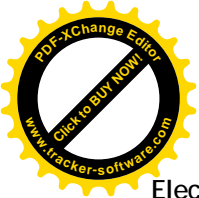

## 12. Environmental Management

All STARCAP products are RoHS compliant, Halogen Free and environment friendly.

| Series | RoHS directive<br>(Pb, Cr+6, Hg,<br>Cd, PBB,PBDE) | ELV directive<br>(Pb, Cr+6,<br>Hg, Cd) | PVC  | Halogen Flame<br>Retardant Free<br>(Cl, Br) | etc. |
|--------|---|--|------|---|------|
| DCL    | N.D.  | N.D.                                   | N.D. | N.D.  |      |

\* N.D. : Not detected or Within Permitted Range

单击下面可查看定价，库存，交付和生命周期等信息

[>>Chipcell](#)