



Constant Current LED driver

General Description

VAS1086 is a wide input range constant current LED driver provides cost-effective solution for advertising light boxes, landscape lighting and other LED illumination application. For most applications, VAS1086 only need one current setting resistor from SET to GND, and one ceramic bypass capacitor from VIN to GND, no aluminum capacitor, Schottky diode or inductor needed. For high current application, several VAS1086 can be connected in parallel to obtain high power output.

VAS1086 make use of an external power resistor to reduce chip power dissipation when poor power supply is used. Meanwhile, the VAS1086 will automatically reduce linearly the output current when the die temperature reached 120°C, this method avoid LED bar blinking. Over temperature protection is also be integrated.

VAS1086 is available with SOP8-e package.

Application

- Advertising light boxes
- Landscape lighting
- The low end of the current sink
- Ideal current source

Features

- Wide input range from 2.7 to 40 V
- Simple application circuits
- Up to 400mA output current capability
- Obtain larger output current by in parallel
- External power resistor avoid over-heat
- $\pm 1\%$ SET voltage accuracy
- Support up to 20KHz PWM dimming
- Over-Temperature-Protection function
- SOP8-e package

Ordering Information

Order Number	Package Type	Temp. Range
VAS1086ID08E	SOP8-e	-40 °C to 85°C

I: Industry, -40~85°C
08 : Pin Number

D: SOP
E: ROHS

Pin Configuration

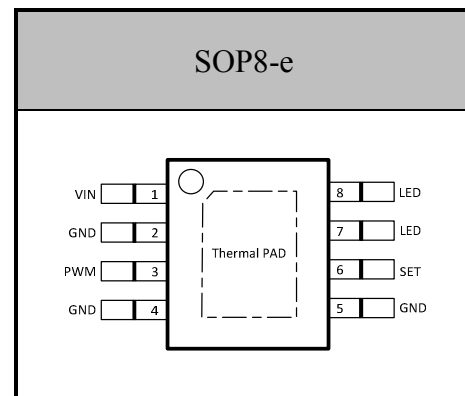

Typical Application Circuit

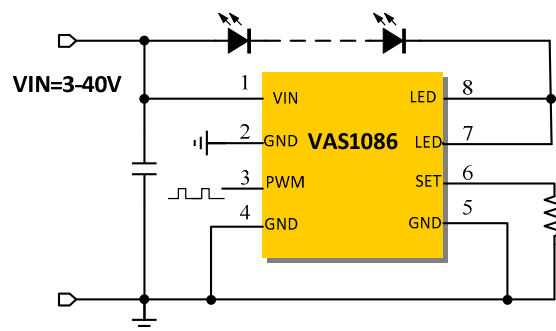

Block Diagram

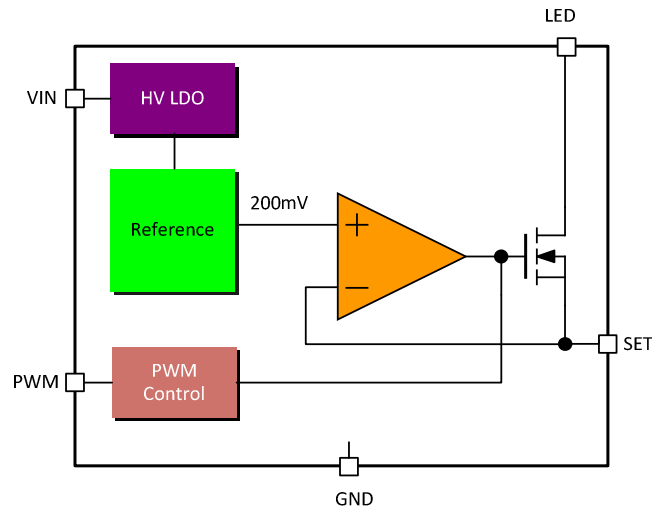

PIN Description

PIN NO.	Name	Description
1	VIN	Power Supply Input, do not over 36V.
2,4,5	GND	Ground
3	PWM	PWM dimming input
6	SET	Current setting pin, connect an external resistor ground to set LED current
7,8	LED	Connect to LED cathode
EP	GND	Exposed Paddle. Connect to a large-area ground plane for improved power dissipation. Do not use as the only ground connection for the device.



Absolute Maximum Ratings^(Note1)

Parameters	Maximum Ratings
VIN,LED,PWM to GND	-0.3V to 44V
SET	-0.3V to 6V
Operating temperature range	-40°C to +85°C
Junction temperature	-40°C to +150°C
Storage temperature range	-65°C to +150°C
ESD human body model	2000V

Note 1: Absolute Maximum Ratings indicate limits beyond which damage to the device may occur. Operating Ratings indicate conditions for which the device is functional, but do not guarantee specific performance limits. Electrical Characteristics state DC and AC electrical specifications under particular test conditions which guarantee specific performance limits. This assumes that the device is within the Operating Ratings. Specifications are not guaranteed for parameters where no limit is given, however, the typical value is a good indication of device performance.

Electrical Characteristics

Test Condition^(Note2): VIN=12V, TA=25°C(unless otherwise specified)

Symbol	Parameter	Condition	SPEC			Unit
			Min	Typ	Max	
VCC	Input voltage range		2.7		40	V
ICC	Quiescent current	No load		200		uA
VSET	SET pin voltage			200		mV
VTHH_PWM	PWM pin enable voltage				1.5	V
VTHL_PWM	PWM pin disable voltage		0.5			V
IACCU	LED current accuracy	VLED=0.5V		±3		%
VHR-LED	Minimum head-rom voltage to maintain LED current	RSET=2Ω,ILED=100mA			0.26	V
RDSO	The conduct resistor between LED to ISET pin	VCC=2.7V~5.5V			0.6	Ω
TSD	Over temperature protection threshold			160		°C
ROJA	Thermal resistance	SOP8-e		60		°C/W

Note 2: Production testing of the device is performed at 25°C. Functional operation of the device and parameters specified over other temperature range, are guaranteed by design, characterization and process control.



Typical Performance Characteristics

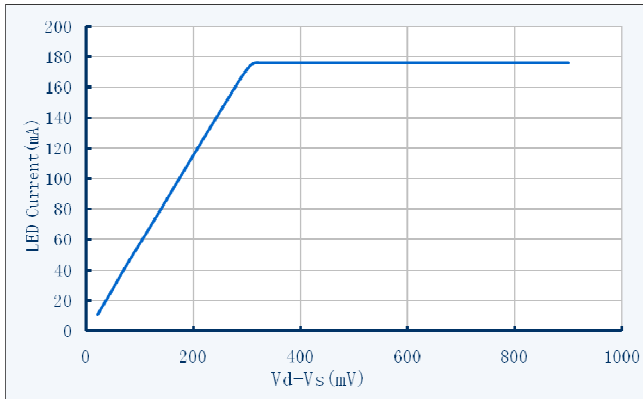

LED current vs. LED pin voltage

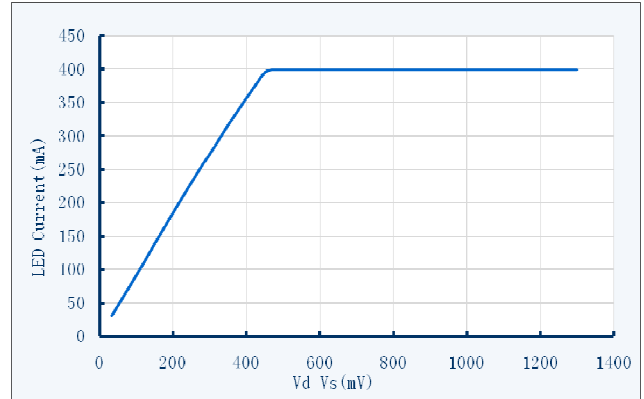

LED current vs. LED pin voltage



Application Information

1. Set LED Current

The VAS1086 feature a programmable LED current using a resistor connected between SET and ground. Use the following equation to calculate the sense resistor:

$$I_{LED} = \frac{0.2V}{R_{SET}}$$

Change the value of R_{SET} can obtain the required constant current. The chip power consumption is $I_{LED} * V_D$, V_D is LED cathode voltage.

In order to get the higher accuracy of the LED output current, a 1% or more high precision resistor is commented. If the environment temperature changes a lot, such as change in $-25^{\circ}C$ to $85^{\circ}C$, use the low temperature coefficient resistance to ensure that the resistance value is almost constant.

2. PWM Dimming

PWM dimming frequency range is 60Hz~20 KHz, the LED average current is proportional to PWM duty cycle. PWM pin can be floating for 100% brightness.

3. Over-Heating Issue

As the LED power supply rises, the LED cathode voltage will follow up, this will cause the chip overheating. The VAS1086 solve the issue by:

1) If the VAS1086 die temperature rise to $120^{\circ}C$ (IC surface temperature is about $80^{\circ}C$), LED current started to decrease gradually, as the temperature reach $160^{\circ}C$, LED current dropped by half.

2) If the temperature continues to increase to $160^{\circ}C$, VAS1086 enter thermal shutdown mode. When the temperature dropped to $120^{\circ}C$, VAS1086 re-start to work again.

4. PCB Layout

Careful PCB layout is critical to achieve low switching losses and stable operation. Connect a $0.1\mu F$ ceramic capacitor between VIN and ground for better noise immunity. The SET pin is a high impedance pin, do not parallel with any capacitor. Minimize the SET pin ground noise by connecting a ground as wide and short as possible. Guard Ring and the similar potential signal (such as GND) line to the surround can prevent R_{SET} interfered.



Package Information (SOP8-e)

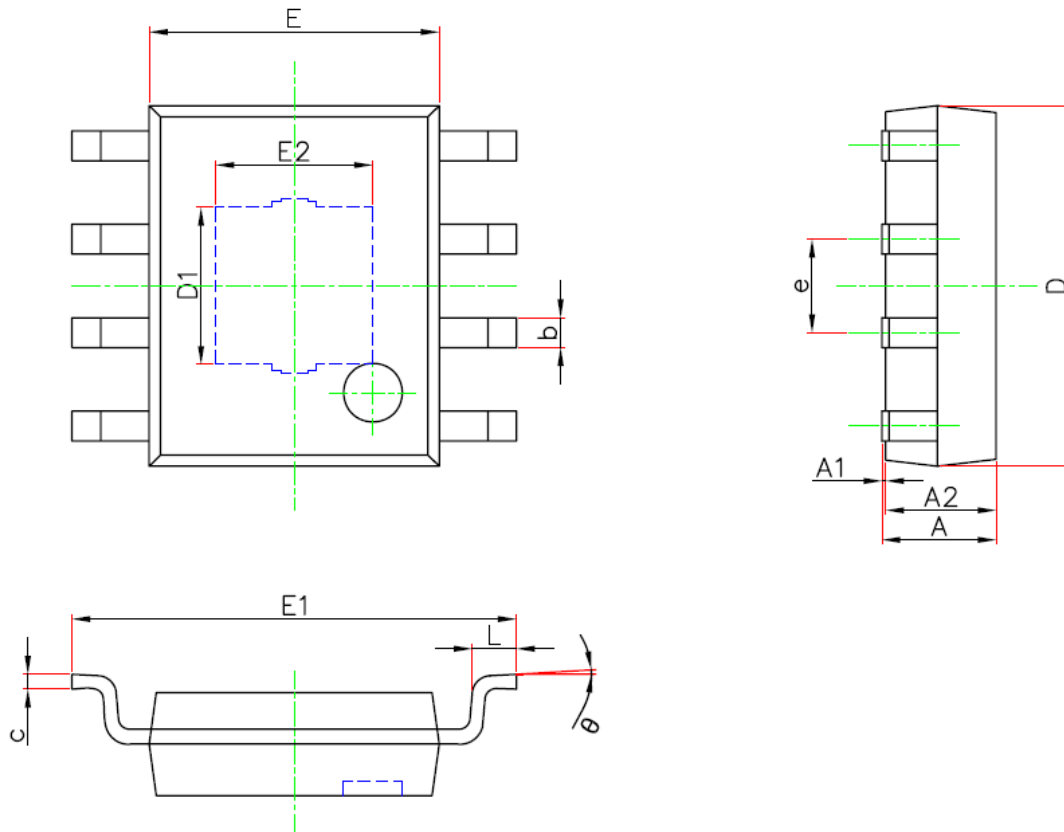

Symbol	Dimensions In Millimeters		Dimensions In Inches	
	Min.	Max.	Min.	Max.
A	1.300	1.700	0.051	0.067
A1	0.000	0.100	0.000	0.004
A2	1.350	1.550	0.053	0.061
b	0.330	0.510	0.013	0.020
c	0.170	0.250	0.007	0.010
D	4.700	5.100	0.185	0.201
D1	2.034	2.234	0.080	0.088
E	3.800	4.000	0.150	0.157
E1	5.800	6.200	0.228	0.244
E2	2.034	2.234	0.080	0.088
e	1.270(BSC)		0.050(BSC)	
L	0.400	1.270	0.016	0.050
θ	0°	8°	0°	8°

Classification Reflow Profiles

Profile Feature	Pb-Free Assembly
Preheat & Soak Temperature min (T _{smin}) Temperature max (T _{smax}) Time (T _{smin} to T _{smax}) (t _s)	150°C 200°C 60-120 seconds
Average ramp-up rate (T _{smax} to T _p)	3°C/second max.
Liquidous temperature (T _L) Time at liquidous (t _L)	217°C 60-150 seconds
Peak package body temperature (T _p)*	Max 260°C
Time (t _p)** within 5°C of the specified classification temperature (T _c)	Max 30 seconds
Average ramp-down rate (T _p to T _{smax})	6°C/second max.
Time 25°C to peak temperature	8 minutes max.

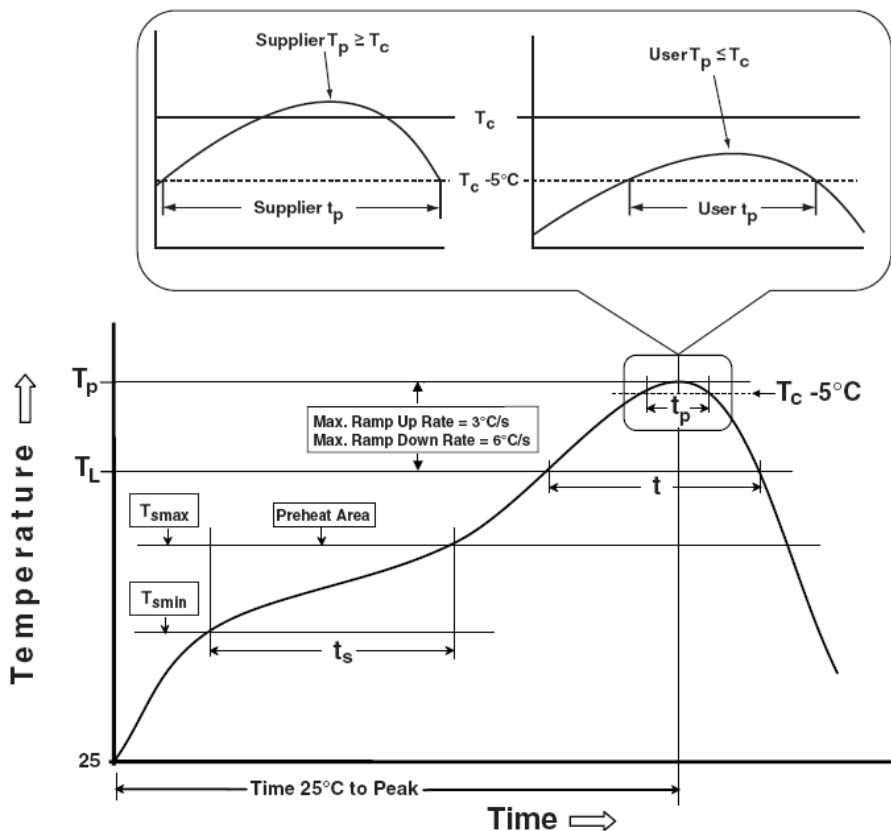

Classification Profile



⚠ CAUTION

Storage Conditions

1) This product should be used within 12 months after delivered. Store in manufacturer's package keeping the seal of aluminum coated baggage or tightly re-closed box with the following conditions. [Temperature:8°C...30°C, Humidity:30%...70% R.H.]

2) Keep the seal of aluminum coated baggage immediately before usage.

3) After breaking the seal of aluminum coated baggage, this product should be used within 1 week on the following conditions.

[Temperature:≤30°C, Humidity: ≤60% R.H.]

单击下面可查看定价，库存，交付和生命周期等信息

[>>Chipllead\(奇力科技\)](#)