

CMI-CMMPP4030HL-SERIES



Features

- ▶ Small size, high current and low profile
- ▶ Metal powder molding type for EMC protection.
- ▶ Available tape and reel for auto insertion.
- ▶ Halogen-Free / RoHS compliant.
- ▶ AEC-Q200 qualified.

Applications

- ▶ Equipment using for automobiles (ECM, airbags, headlights, electronic Powder steering, motors, ABS, other)



Dimension (Unit:mm)

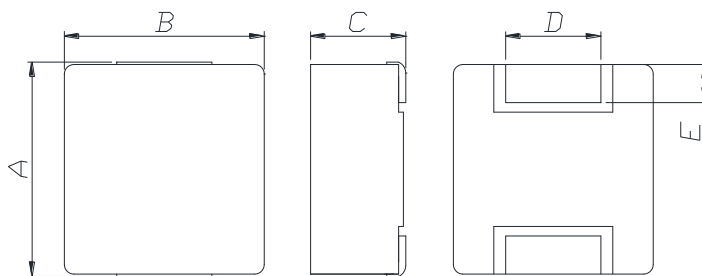

A	B	C	D	E
4.4±0.35	4.2±0.25	3.0 Max	2.0±0.2	0.8±0.2

Land Pattern (Unit:mm)

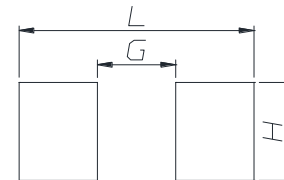

L	G	H
4.8	1.6	2.0

Specifications

Part Number	Inductance (uH) ±20%	DCR(mohm) Max(Typ)	Isat(A) Max(Typ)	Itemp(A) Max(Typ)	Test Frequency (Hz)
CMI-CMMPP4030HL-R47M	0.47	10.8(9)	12.00(13.00)	9.00(10.00)	1M
CMI-CMMPP4030HL-1R8M	1.8	28.8(24)	6.50(7.30)	5.80(6.50)	1M
CMI-CMMPP4030HL-2R2M	2.2	30(25)	6.30(7.00)	5.70(6.40)	1M
CMI-CMMPP4030HL-3R3M	3.3	50(42)	6.10(6.80)	4.00(4.60)	1M
CMI-CMMPP4030HL-4R7M	4.7	60(45)	5.40(6.00)	3.60(4.00)	1M
CMI-CMMPP4030HL-6R8M	6.8	84(70)	3.50(3.90)	2.70(3.00)	1M
CMI-CMMPP4030HL-100M	10	154(128)	3.30(3.70)	2.20(2.50)	1M

- Isat: When based on the inductance change rate (approximately 30% below in the initial value)
- Itemp: When based on the temperature increase (Temperature increase of approximately 40°C by self heating)
- Operating Temperature Range(including self temperature) : -40°C ~ +165 °C

Note 1 : Circuit design, component placement, PCB trace size and thickness, airflow and other cooling. Provision all affect the part Temperature. Part temperature should be verified in the end application.

- All specifications are subject to change without notice.
- Update date : 2019.02.08

www.coilmaster.com

DC BIAS vs INDUCTANCE

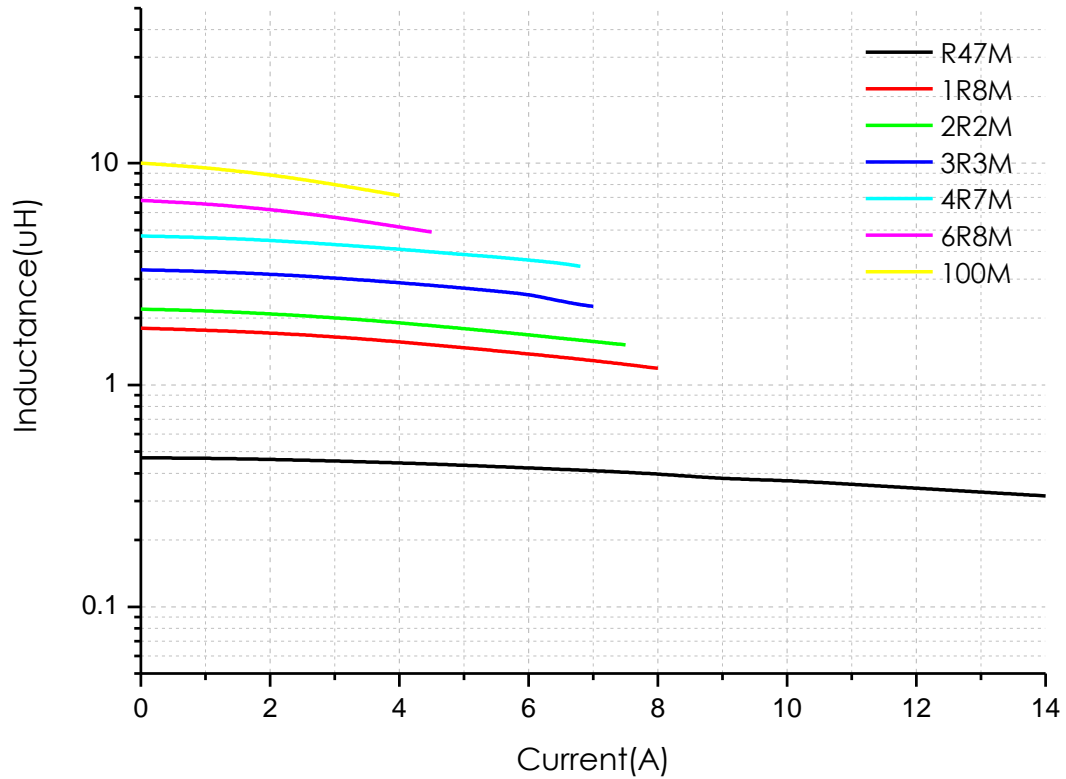

T

DC BIAS vs TEMPERATURE

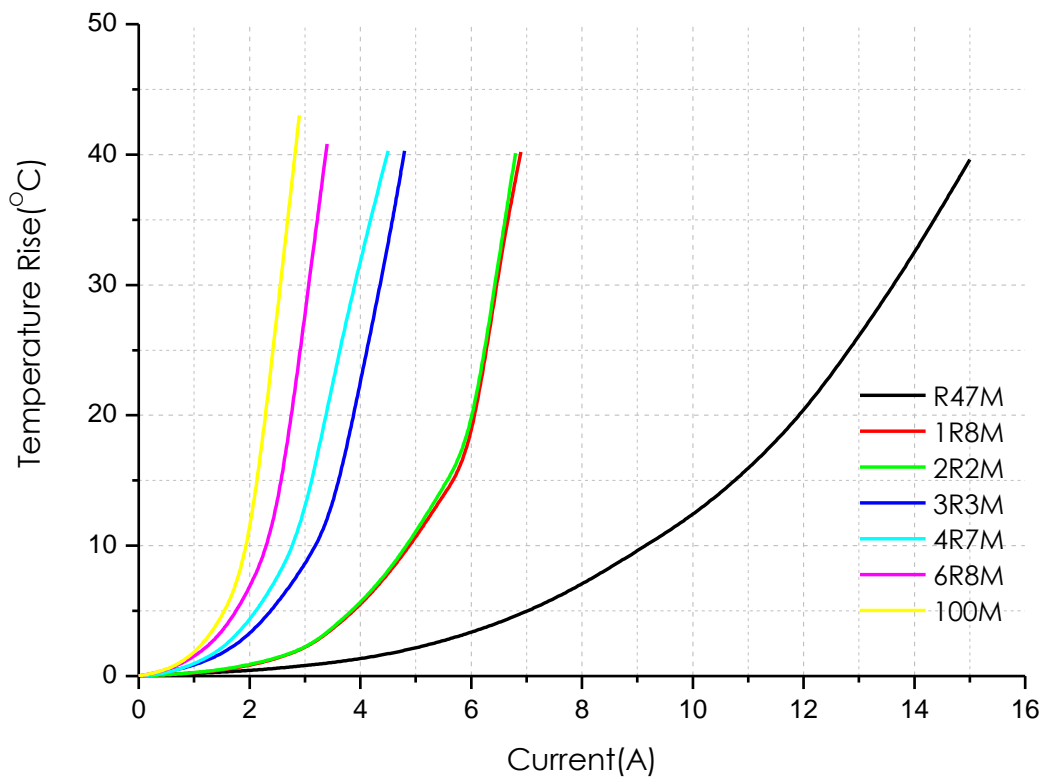

- All specifications are subject to change without notice.
- Update date : 2019.02.08

Packaging

(1) Package quantity : 2,000 (pcs/reel)

(2) Reel Dimensions (unit:mm)

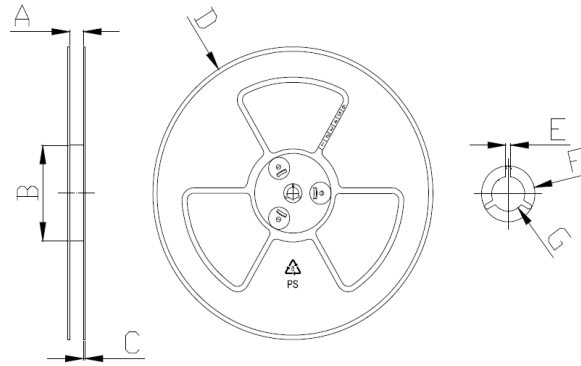

A	B	C	D	E	F	G
12.50	100.0	2.00	330.0	1.90	21.00	13.00
+1.00	+1.50	+0.10	+1.00	+0.40	+0.40	+0.40
-1.00	-1.50	-0.10	-1.00	-0.40	-0.40	-0.40

(3) Tape Dimensions

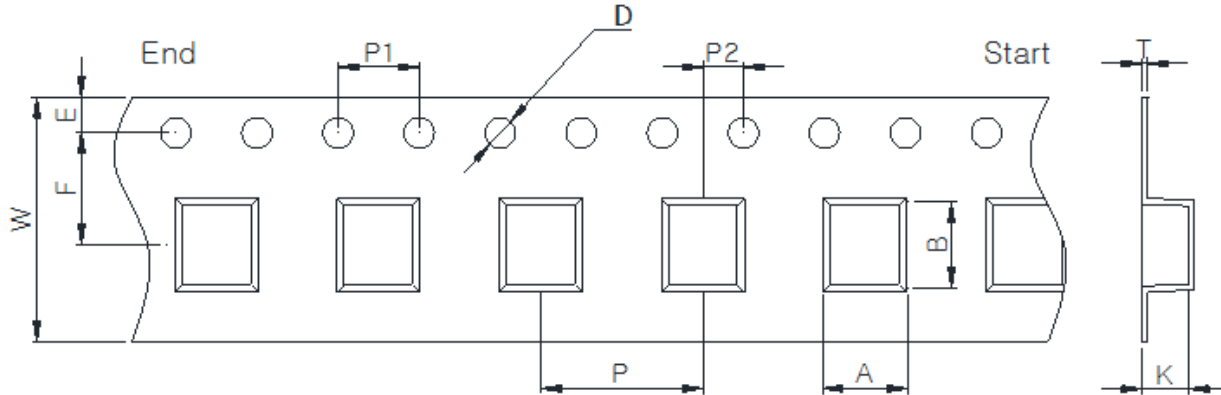

W	A	B	K	E	F	P	P1	P2	D	T
12.00	4.50	4.80	3.20	1.75	5.50	8.00	4.00	2.00	1.50	0.40
+0.30	+0.10	+0.10	+0.10	+0.10	+0.10	+0.10	+0.10	+0.10	+0.10	+0.05
-0.10	-0.10	-0.10	-0.10	-0.10	-0.10	-0.10	-0.10	-0.10	-0.00	-0.05

Ilisan Sales Office (KOREA) +82)31-904-1444
 Shenzhen Sales Office (CHINA) +86)755-8663-6929
 Hungary Sales office (EUROPE) +36)30-913-7706

H.K Sales Office (HONGKONG) +852)2711-5551
 LA Sales Office (USA) +1)866-446-3586

- All specifications are subject to change without notice.
- Update date : 2019.02.08

www.coilmaster.com

单击下面可查看定价，库存，交付和生命周期等信息

[>>coilmaster\(卡尔马斯特\)](#)