

2W005M THRU 2W10M

SINGLE-PHASE SILICON BRIDGE RECTIFIER



REVERSE VOLTAGE: 50 to 1000 VOLTS
FORWARD CURRENT: 2.0 AMPERE

FEATURES

- Surge overload rating: 50 amperes peak
- Ideal for printed circuit board
- Reliable low cost construction utilizing molded plastic technique
- High temperature soldering guaranteed: 250°C/10SEC/ 9.5mm lead length at 2.3kg tension

MECHANICAL DATA

Case: Reliable low cost construction utilizing molded plastic technique results in inexpensive product

Terminals: Leads solderable per MIL-STD-202, method 208 guaranteed

Mounting position: Any

Weight: 0.05ounce, 1.3gram

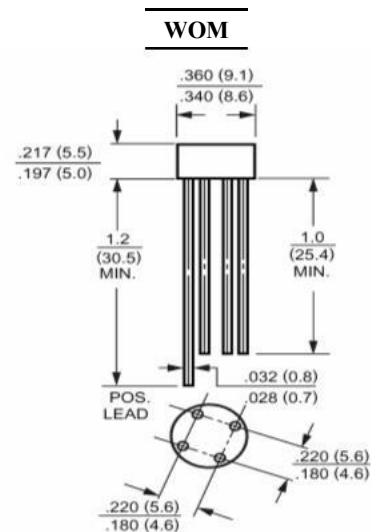

Dimensions in inches and (millimeters)

Maximum Ratings and Electrical Characteristics

Ratings at 25°C ambient temperature unless otherwise specified.

Single phase, half wave, 60Hz, resistive or inductive load.

For capacitive load, derate current by 20%.

	Symbols	2W005M	2W01M	2W02M	2W04M	2W06M	2W08M	2W10M	Units
Maximum Recerrent Peak Reverse Voltage	V _{RRM}	50	100	200	400	600	800	1000	Volts
Maximum RMS Voltage	V _{RMS}	35	70	140	280	420	560	700	Volts
Maximum DC Blocking Voltage	V _{DC}	50	100	200	400	600	800	1000	Volts
Maximum Average Forward Rectified Current .375"(9.5mm) Lead Length at T _A =50°C	I _(AV)	2.0							Amp
Peak Forward Surge Current, 8.3ms single half-sine-wave superimposed on rated load (JEDEC method)	I _{FSM}	50.0							Amp
Maximum Forward Voltage at 2.0A DC and 25°C	V _F	1.1							Volts
Maximum Reverse Current at T _A =25°C at Rated DC Blocking Voltage T _A =100°C	I _R	5.0 500							uAmp
Typical Junction Capacitance (Note 1)	C _J	40				20			pF
Typical Thermal Resistance (Note 2)	R _{θJA}	40.0							°C/W
Typical Thermal Resistance (Note 2)	R _{θJL}	15.0							°C/W
Operating and Storage Temperature Range	T _J Tstg	-55 to +125							°C

NOTES:

1- Measured at 1 MHz and applied reverse voltage of 4.0 VDC.

2- Thermal Resistance Junction to Ambient and form junction to lead at 0.375"(9.5mm) lead length P.C.B. Mounted.

<http://www.comonsemi.com>

<http://www.ndone.cn>

2W005M THRU 2W10M

SINGLE-PHASE SILICON BRIDGE RECTIFIER

RATINGS AND CHARACTERISTIC CURVES

FIG.1- MAXIMUM NON-REPETITIVE FORWARD SURGE CURRENT PER BRIDGE ELEMENT

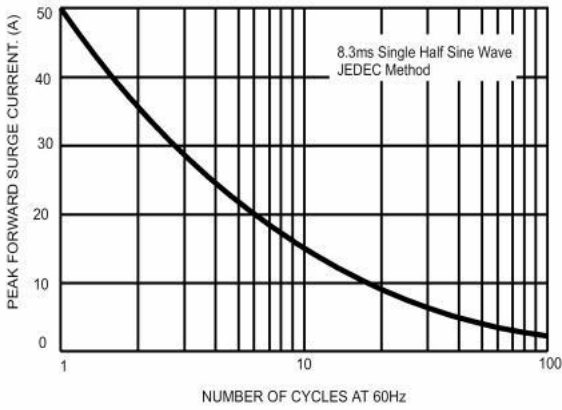

FIG.2- MAXIMUM CURRENT DERATING CURVE OUTPUT RECTIFIED CURRENT

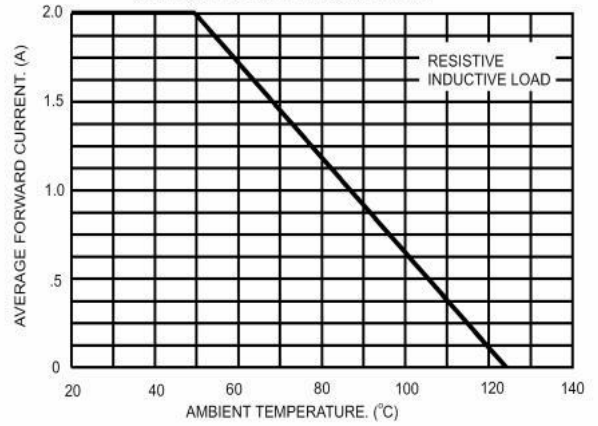

FIG.3- TYPICAL INSTANTANEOUS FORWARD CHARACTERISTICS PER BRIDGE ELEMENT

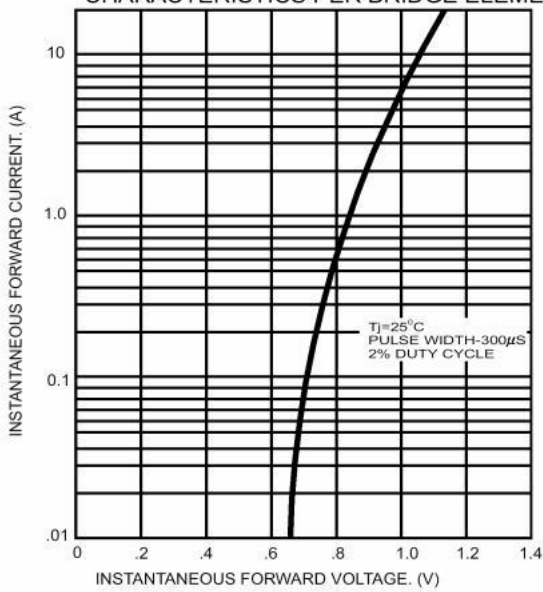
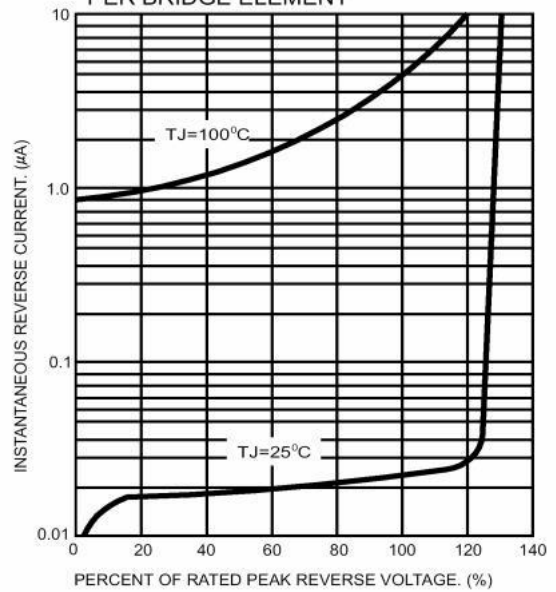

FIG.4- TYPICAL REVERSE CHARACTERISTICS PER BRIDGE ELEMENT



单击下面可查看定价，库存，交付和生命周期等信息

[>>COMON\(阔迈\)](#)