

## Zener diode

### Features

1. High reliability
2. Very sharp reverse characteristic
3. Low reverse current level
4.  $V_z$ -tolerance  $\pm 5\%$



### Applications

Voltage stabilization

### Absolute Maximum Ratings

$T=25^\circ\text{C}$

Parameter	Test Conditions	Type	Symbol	Value	Unit
Power dissipation	$T_{amb} \leq 75^\circ\text{C}$		$P_V$	500	mW
Z-current			$I_z$	$P_V / V_z$	mA
Junction temperature			$T_j$	200	$^\circ\text{C}$
Storage temperature range			$T_{stg}$	-65~+200	$^\circ\text{C}$

### Maximum Thermal Resistance

$T=25^\circ\text{C}$

Parameter	Test Conditions	Symbol	Value	Unit
Junction ambient	$l=9.5\text{mm}(3/8") T_L=\text{constant}$	$R_{thJA}$	300	K/W

Stresses exceeding maximum ratings may damage the device. Maximum ratings are stress ratings only. Functional operation above the recommended operating conditions is not implied. Extended exposure to stresses above the recommended operating conditions may affect device reliability.

### Electrical Characteristics

$T=25^\circ\text{C}$

Parameter	Test Conditions	Type	Symbol	Min	Typ	Max	Unit
Forward voltage	$I_F=200\text{mA}$		$V_F$			1.1	V

# LL5221B~LL5271B



Type	V <sub>Znom1</sub> )	I <sub>ZT</sub>	for	r <sub>ZT</sub>	r <sub>ZK</sub>	at	I <sub>ZK</sub>	I <sub>R</sub>	at	V <sub>R</sub>	TK <sub>vz</sub>
	V	mA		Ω	Ω		mA	μA		V	%/K
LL5221B	2.4	20		<30	<1200		0.25	<100		1.0	<-0.085
LL5222B	2.5	20		<30	<1250		0.25	<100		1.0	<-0.085
LL5223B	2.7	20		<30	<1300		0.25	<75		1.0	<-0.080
LL5224B	2.8	20		<30	<1400		0.25	<75		1.0	<-0.080
LL5225B	3.0	20		<29	<1600		0.25	<50		1.0	<-0.075
LL5226B	3.3	20		<28	<1600		0.25	<25		1.0	<-0.070
LL5227B	3.6	20		<24	<1700		0.25	<15		1.0	<-0.065
LL5228B	3.9	20		<23	<1900		0.25	<10		1.0	<-0.060
LL5229B	4.3	20		<22	<2000		0.25	<5		1.0	<+0.055
LL5230B	4.7	20		<19	<1900		0.25	<5		2.0	<+0.030
LL5231B	5.1	20		<17	<1600		0.25	<5		2.0	<+0.030
LL5232B	5.6	20		<11	<1600		0.25	<5		3.0	<+0.038
LL5233B	6.0	20		<7	<1600		0.25	<5		3.5	<+0.038
LL5234B	6.2	20		<7	<1000		0.25	<5		4.0	<+0.045
LL5235B	6.8	20		<5	<750		0.25	<3		5.0	<+0.050
LL5236B	7.5	20		<6	<500		0.25	<3		6.0	<+0.058
LL5237B	8.2	20		<8	<500		0.25	<3		6.5	<+0.062
LL5238B	8.7	20		<8	<600		0.25	<3		6.5	<+0.065
LL5239B	9.1	20		<10	<600		0.25	<3		7.0	<+0.068
LL5240B	10	20		<17	<600		0.25	<3		8.0	<+0.075
LL5241B	11	20		<22	<600		0.25	<2		8.4	<+0.076
LL5242B	12	20		<30	<600		0.25	<1		9.1	<+0.077
LL5243B	13	9.5		<13	<600		0.25	<0.5		9.9	<+0.079
LL5244B	14	9.0		<15	<600		0.25	<0.1		10	<+0.082
LL5245B	15	8.5		<16	<600		0.25	<0.1		11	<+0.082
LL5246B	16	7.8		<17	<600		0.25	<0.1		12	<+0.083
LL5247B	17	7.4		<19	<600		0.25	<0.1		13	<+0.084
LL5248B	18	7.0		<21	<600		0.25	<0.1		14	<+0.085
LL5249B	19	6.6		<23	<600		0.25	<0.1		15	<+0.086
LL5250B	20	6.2		<25	<600		0.25	<0.1		16	<+0.086
LL5251B	22	5.6		<29	<600		0.25	<0.1		17	<+0.087
LL5252B	24	5.2		<33	<600		0.25	<0.1		18	<+0.088
LL5253B	25	5.0		<35	<600		0.25	<0.1		19	<+0.089
LL5254B	27	4.6		<41	<600		0.25	<0.1		21	<+0.090
LL5255B	28	4.5		<44	<600		0.25	<0.1		21	<+0.091
LL5256B	30	4.2		<49	<600		0.25	<0.1		23	<+0.091
LL5257B	33	3.8		<58	<700		0.25	<0.1		25	<+0.092
LL5258B	36	3.4		<70	<700		0.25	<0.1		27	<+0.093
LL5259B	39	3.2		<80	<800		0.25	<0.1		30	<+0.094
LL5260B	43	3.0		<93	<900		0.25	<0.1		33	<+0.095
LL5261B	47	2.7		<105	<1000		0.25	<0.1		36	<+0.095
LL5262B	51	2.5		<125	<1100		0.25	<0.1		39	<+0.096
LL5263B	56	2.2		<150	<1300		0.25	<0.1		43	<+0.096
LL5264B	60	2.1		<170	<1400		0.25	<0.1		46	<+0.097
LL5265B	62	2.0		<185	<1400		0.25	<0.1		47	<+0.097
LL5266B	68	1.8		<230	<1600		0.25	<0.1		52	<+0.097
LL5267B	75	1.7		<270	<1700		0.25	<0.1		58	<+0.098
LL5268B	82	1.5		<330	<2000		0.25	<0.1		62	<+0.098
LL5269B	87	1.4		<370	<2200		0.25	<0.1		68	<+0.099
LL5270B	91	1.4		<400	<2300		0.25	<0.1		69	<+0.099
LL5271B	100	1.3		<500	<2600		0.25	<0.1		76	<+0.11

1) Based on DC-measurement at thermal equilibrium while maintaining the lead temperature(T<sub>L</sub>) at 30°C, 9.5mm (3/8") from the diode body.

Characteristics (T=25°C unless otherwise specified)

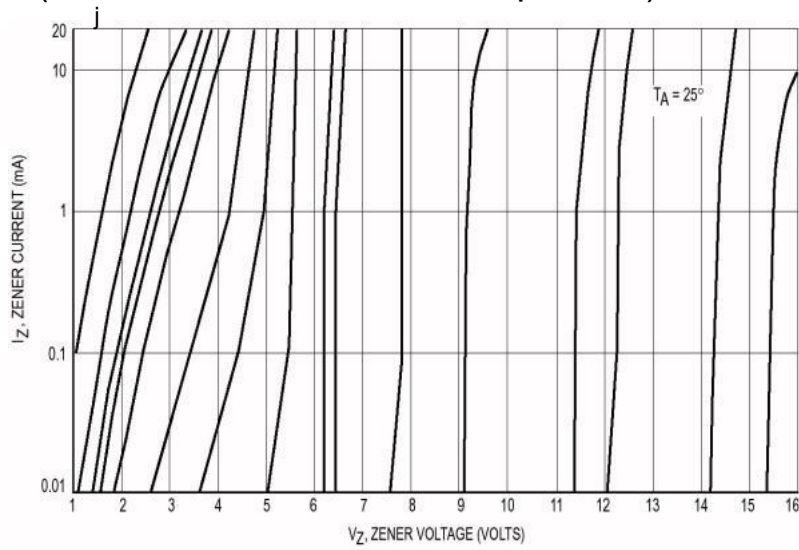

Figure 1. Zener Voltage versus Zener Current –  $V_Z=1$  thru 16 Volts

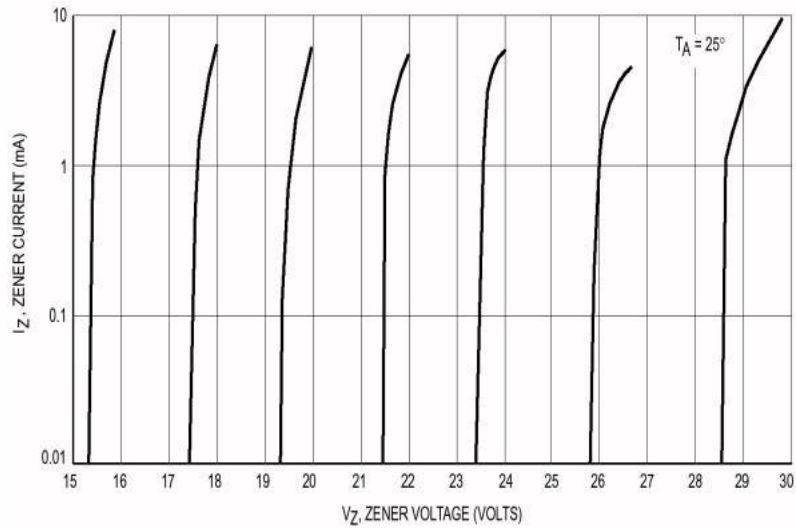

Figure 2. Zener Voltage versus Zener Current –  $V_Z=15$  thru 30 Volts

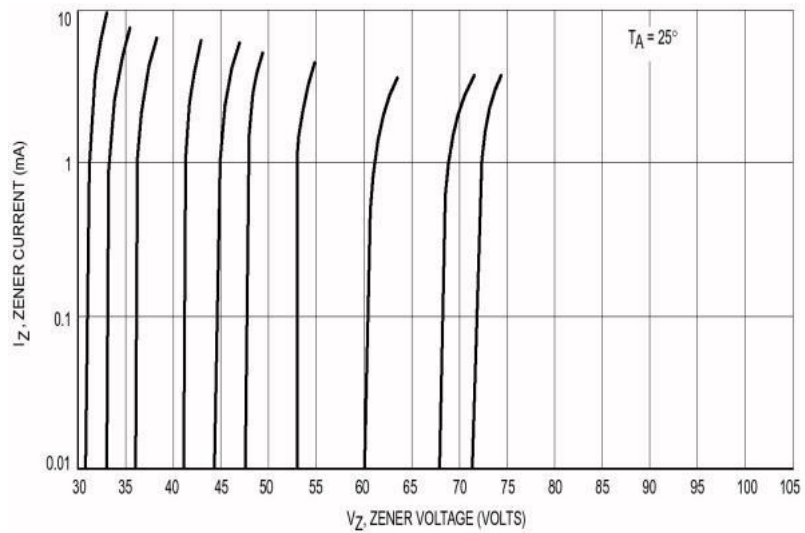

Figure 3. Zener Voltage versus Zener Current –  $V_Z=30$  thru 75 Volts

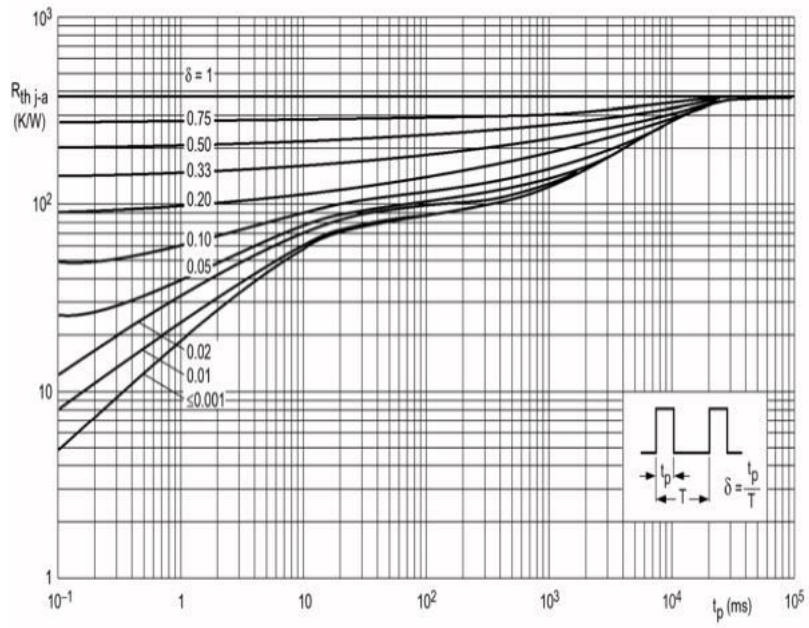
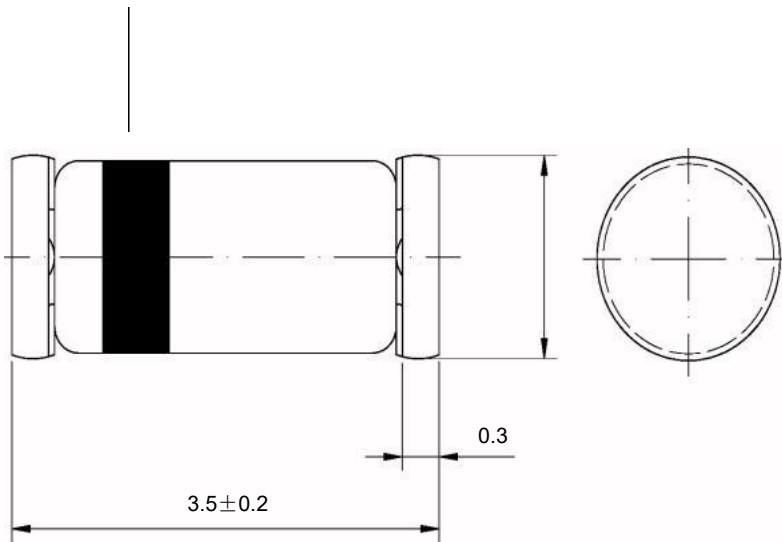

Figure 4. Thermal resistance from junction to ambient as a function of pulse duration

Dimensions in mm

Cathode identification



Glass Case  
 Mini Melf / SOD-80  
 JEDEC DO-213 AA

单击下面可查看定价，库存，交付和生命周期等信息

[>>COMON\(阔迈\)](#)