

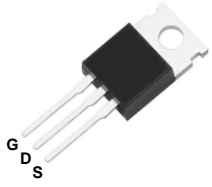

N-channel 650V, 0.86Ω typ.,
 Super Junction MOSFET G2 in TO-220, TO-251, TO-252 and TO-220F

Datasheet - production data

1. Descriptions

TO-220	TO-251
	
TO-252	TO-220F
	
N-Channel MOSFET	
 <p style="text-align: center;">POWER MOSFET</p>	

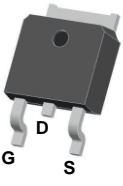
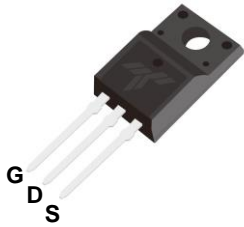
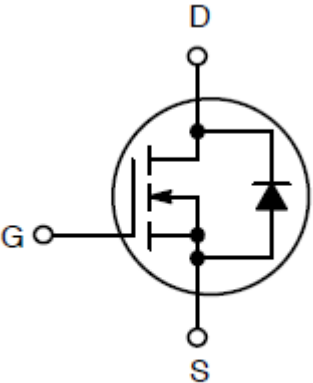
Key Performance Parameters

Parameters	Value	Unit
BV_{DSS}	650	V
$R_{DS(on),max}$	0.95	Ω
$Q_{g,typ}$	7.7	nC
$I_{D,pulse}$	8	A
E_{AS}	100	mJ

Features

- Extremely Low Losses Due to Very Low FOM $R_{ds(on)} \cdot Q_g$ and E_{oss} .
- Very High Commutation Ruggedness.
- Qualified for Industrial Grade Applications According to JEDEC.

Applications

PFC Stages, Hard Switching PWM Stages and Resonant Switching PWM Stages for Adapter, LCD TV, Lighting, and UPS.

Type/Ordering Code	Package	Marking	Related Links
CPP65R950G2	TO-220	65R950G2	See Appendix A
CPI65R950G2	TO-251		
CPD65R950G2	TO-252		
CPA65R950G2	TO-220F		

Contents

1.	Descriptions	1
2.	Maximum Ratings	3
3.	Thermal Characteristics	4
4.	Electrical Characteristics	5
5.	Electrical Characteristics Diagrams	6
6.	Test Circuits	10
7.	Package Outlines	11
8.	Appendix	15

2. Maximum Ratings

At $T_j = 25^\circ\text{C}$, unless otherwise specified

Table 1. Absolute Maximum Ratings

Symbol	Parameter	Values			Unit	Test Condition
		Min.	Typ.	Max.		
V_{DS}	Drain-source voltage ¹⁾	-	-	650	V	$V_{GS}=0\text{V}$, $I_D=250\mu\text{A}$
I_D	Continuous drain current ²⁾	-	-	4.5 3.0	A	$T_C=25^\circ\text{C}$ $T_C=125^\circ\text{C}$
$I_{D,pulse}$	Pulsed drain current	-	-	8	A	$T_C=25^\circ\text{C}$
E_{AS}	Avalanche energy, single pulse ³⁾	-	-	100	mJ	$I_D=2\text{A}$; $V_{DD}=50\text{V}$
I_{AR}	Avalanche current, repetitive	-	-	2	A	-
dv/dt	MOSFET dv/dt ruggedness	-	-	50	V/ns	$V_{DS}=0\dots520\text{V}$
V_{GS}	Gate source voltage	-30	-	30	V	static; AC ($f>1\text{ Hz}$)
P_{tot}	Power dissipation (Non FullPAK) TO-220, TO-251, TO-252	-	-	37	W	$T_C=25^\circ\text{C}$
P_{tot}	Power dissipation (FullPAK) TO-220F	-	-	28	W	$T_C=25^\circ\text{C}$
T_j, T_{stg}	Operating and storage temperature	-55	-	150	$^\circ\text{C}$	-
I_S	Continuous diode forward current	-	-	4.5	A	$T_C=25^\circ\text{C}$
$I_{S,pulse}$	Diode pulse current ²⁾	-	-	8	A	$T_C=25^\circ\text{C}$
dv/dt	Reverse diode dv/dt ⁴⁾	-	-	15	V/ns	$V_{DS}=0\dots400\text{V}$, $I_{SD}\leq I_S$, $T_j=25^\circ\text{C}$
di/dt	Maximum diode commutation speed ⁴⁾	-	-	500	A/ μs	$V_{DS}=0\dots400\text{V}$, $I_{SD}\leq I_S$, $T_j=25^\circ\text{C}$

1) Limited by $T_{j,max}$. Maximum duty cycle $D=0.75$.

2) Pulse width t_p limited by $T_{j,max}$.

3) $V_{DD}=50\text{V}$, $R_G=25\Omega$, Starting $T_j=25^\circ\text{C}$.

4) $V_{DClink}=400\text{V}$; $V_{DS,peak}<V_{(BR)DSS}$; identical low side and high side switch with identical R_G .

3. Thermal Characteristics

Table 2. Thermal Characteristics (Non FullPAK) TO-220, TO-251, TO-252

Symbol	Parameter	Values			Unit	Test Condition
		Min.	Typ.	Max.		
R_{thJC}	Thermal resistance, junction - case	-	-	3.4	°C/W	$T_C = 25^\circ\text{C}$
R_{thJA}	Thermal resistance, junction - ambient	-	-	62	°C/W	$T_C = 25^\circ\text{C}$
T_{sold}	Soldering temperature, wavesoldering only allowed at leads	-	-	260	°C	Lead Temperature (Soldering, 10 sec)

Table 3. Thermal Characteristics (FullPAK) TO-220F

Symbol	Parameter	Values			Unit	Test Condition
		Min.	Typ.	Max.		
R_{thJC}	Thermal resistance, junction - case	-	-	4.5	°C/W	$T_C = 25^\circ\text{C}$
R_{thJA}	Thermal resistance, junction - ambient	-	-	62.5	°C/W	$T_C = 25^\circ\text{C}$
T_{sold}	Soldering temperature, wavesoldering only allowed at leads	-	-	260	°C	Lead Temperature (Soldering, 10 sec)

4. Electrical Characteristics

at $T_j = 25^\circ\text{C}$, unless otherwise specified

Table 4. Static Characteristics

Symbol	Parameter	Values			Unit	Test Condition
		Min.	Typ.	Max.		
$V_{(BR)DSS}$	Drain-source breakdown voltage	650	-	-	V	$V_{GS}=0V, I_D=250\mu A$
$V_{(GS)th}$	Gate threshold voltage	2.0	3.3	4.0	V	$V_{DS}=V_{GS}, I_D=250\mu A$
I_{DSS}	Zero gate voltage drain current	-	-	1 10	μA	$V_{DS}=650V, V_{GS}=0V, T_j=25^\circ C$ $V_{DS}=650V, V_{GS}=0V, T_j=150^\circ C$
I_{GSS}	Gate-source leakage current	-	-	± 100	nA	$V_{GS}=\pm 20V, V_{DS}=0V$
$R_{DS(on)}$	Drain-source on-state resistance	-	0.86 2.1	0.95 2.35	Ω	$V_{GS}=10V, I_D=1.5A, T_j=25^\circ C$ $V_{GS}=10V, I_D=1.5A, T_j=150^\circ C$
R_G	Gate resistance	-	3.8	-	Ω	$V_{DD}=0V, V_{GS}=0V, F=1MHz$

Table 5. Dynamic Characteristics

Symbol	Parameter	Values			Unit	Test Condition
		Min.	Typ.	Max.		
C_{iss}	Input capacitance	-	263	-	pF	$V_{GS}=0V, V_{DS}=50V, f=1MHz$
C_{oss}	Output capacitance	-	19.9	-	pF	$V_{GS}=0V, V_{DS}=50V, f=1MHz$
C_{riss}	Reverse transfer capacitance	-	1.82	-	pF	$V_{GS}=0V, V_{DS}=50V, f=1MHz$
$t_{d(on)}$	Turn-on delay time	-	12.8	-	ns	$V_{DD}=400V, V_{GS}=10V, I_D=2.2A,$
t_r	Rise time	-	26.4	-	ns	$V_{DD}=400V, V_{GS}=10V, I_D=2.2A,$
$t_{d(off)}$	Turn-off delay time	-	22.2	-	ns	$V_{DD}=400V, V_{GS}=10V, I_D=2.2A,$
t_f	Fall time	-	75.6	-	ns	$V_{DD}=400V, V_{GS}=10V, I_D=2.2A,$

Table 6. Gate Charge Characteristics

Symbol	Parameter	Values			Unit	Test Condition
		Min.	Typ.	Max.		
Q_{gs}	Gate to source charge	-	1.07	-	nC	$V_{DD}=480V, I_D=2A, V_{GS}=0 \text{ to } 10V$
Q_{gd}	Gate to drain charge	-	3.63	-	nC	$V_{DD}=480V, I_D=2A, V_{GS}=0 \text{ to } 10V$
Q_g	Gate charge total	-	7.72	-	nC	$V_{DD}=480V, I_D=2A, V_{GS}=0 \text{ to } 10V$
$V_{plateau}$	Gate plateau voltage	-	3.91	-	V	$V_{DD}=480V, I_D=2A, V_{GS}=0 \text{ to } 10V$

Table 7. Reverse Diode Characteristics

Symbol	Parameter	Values			Unit	Test Condition
		Min.	Typ.	Max.		
V_{SD}	Diode forward voltage	-	0.818	-	V	$V_{GS}=0V, I_F=2A, T_j=25^\circ C$
t_{rr}	Reverse recovery time	-	170	-	ns	$V_R=400V, I_F=2.2A, di_F/dt=100A/\mu s$
Q_{rr}	Reverse recovery charge	-	0.92	-	μC	$V_R=400V, I_F=2.2A, di_F/dt=100A/\mu s$
I_{rrm}	Peak reverse recovery current	-	10.4	-	A	$V_R=400V, I_F=2.2A, di_F/dt=100A/\mu s$

5. Electrical Characteristics Diagrams

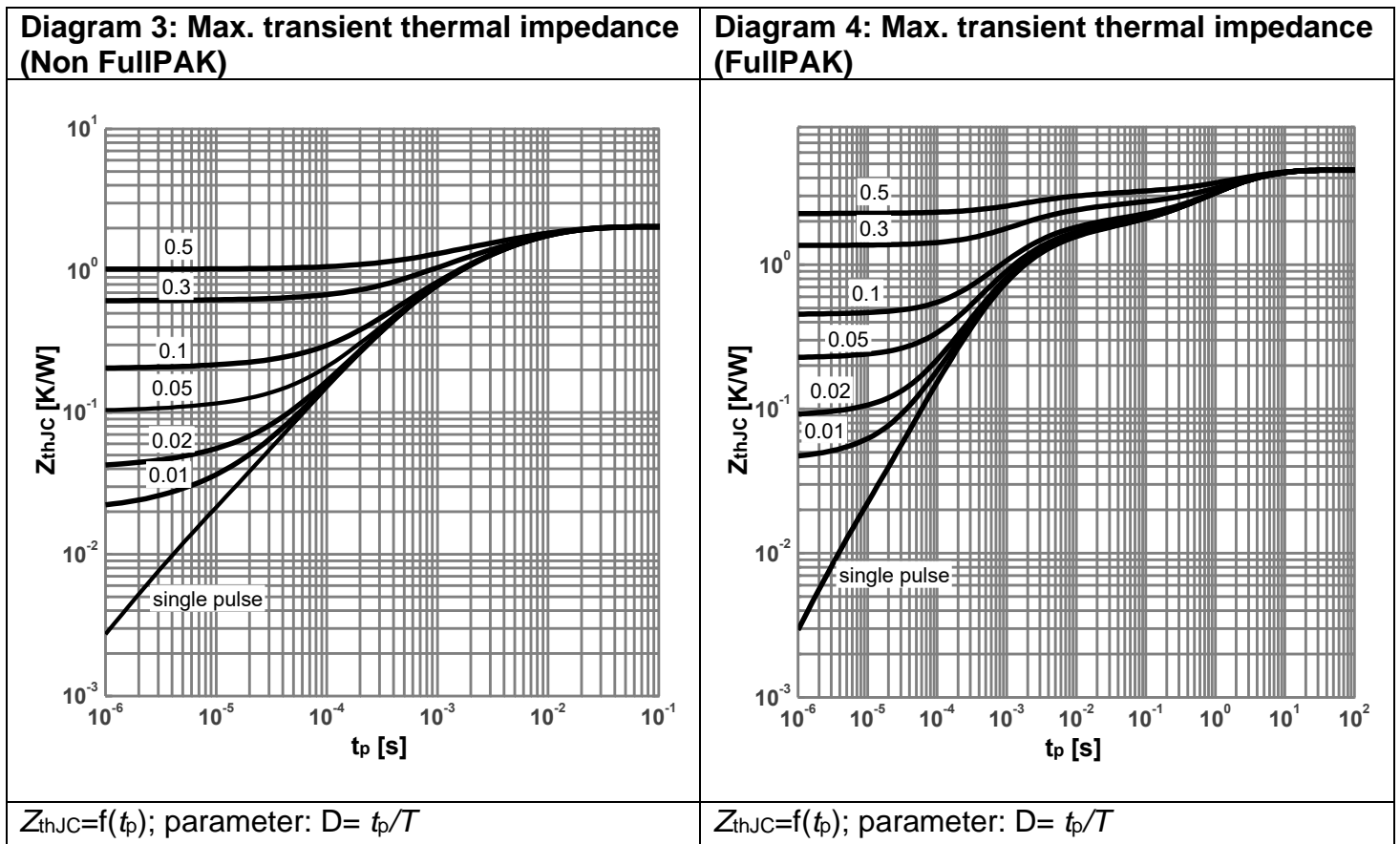
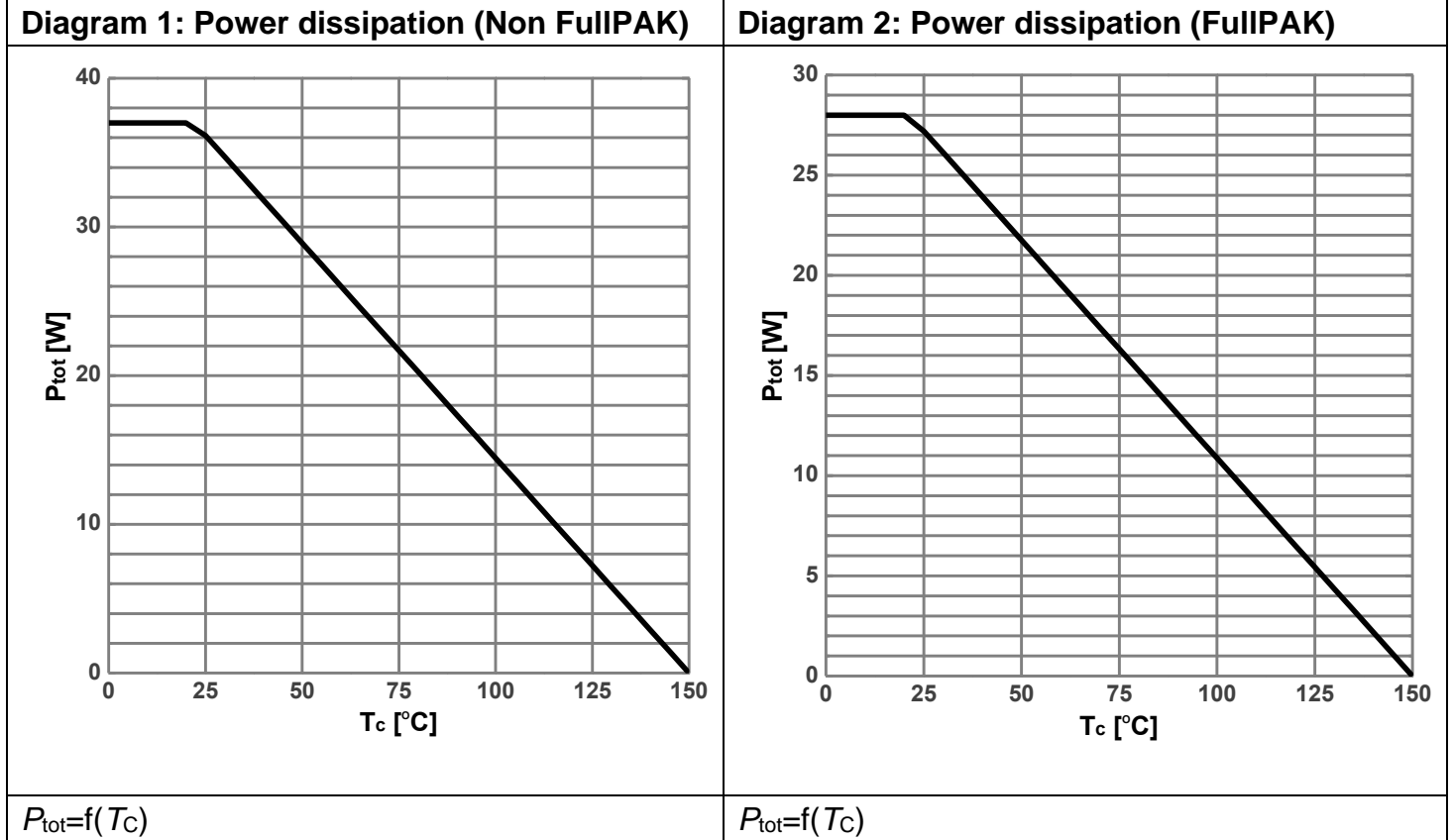

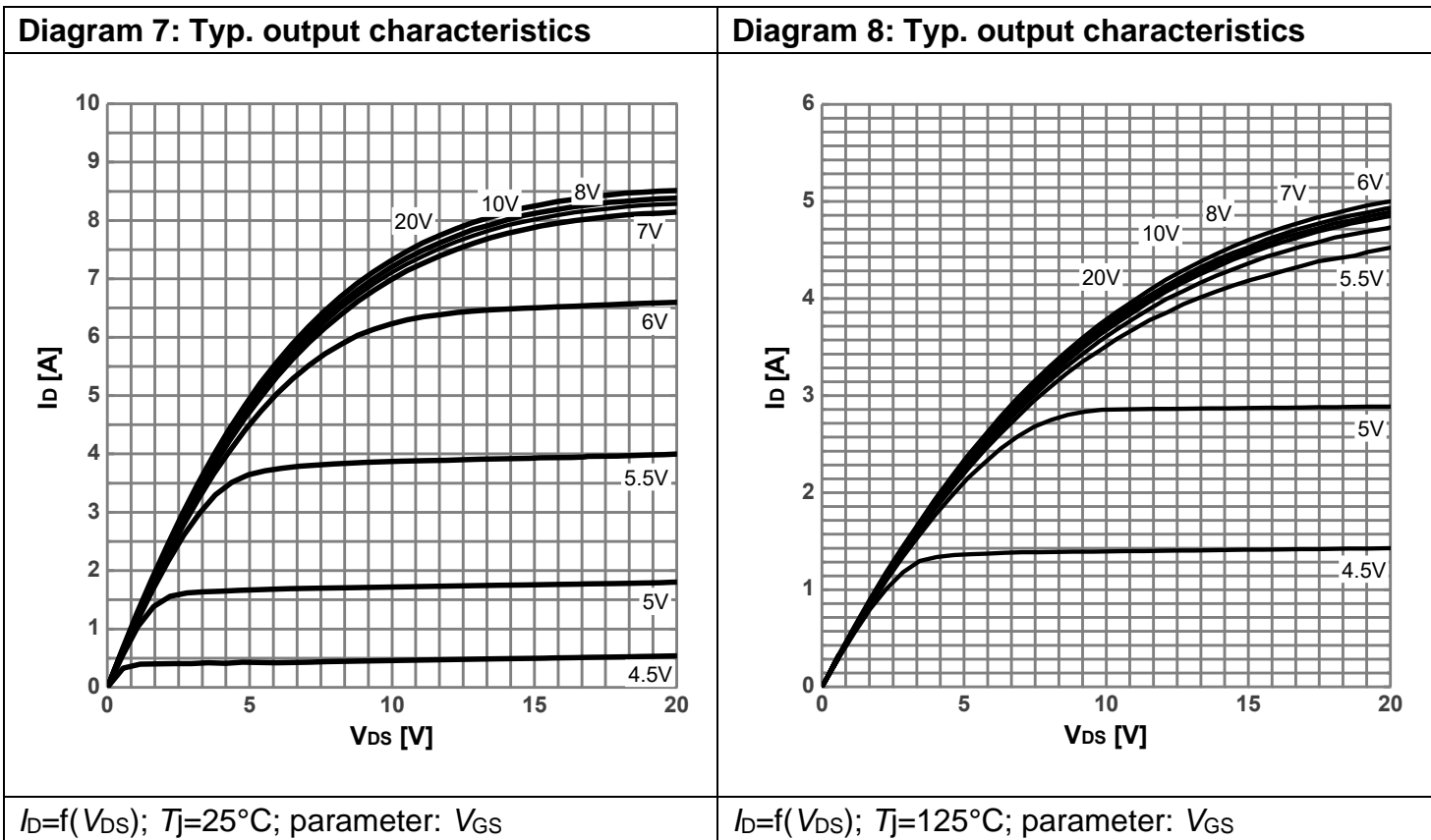
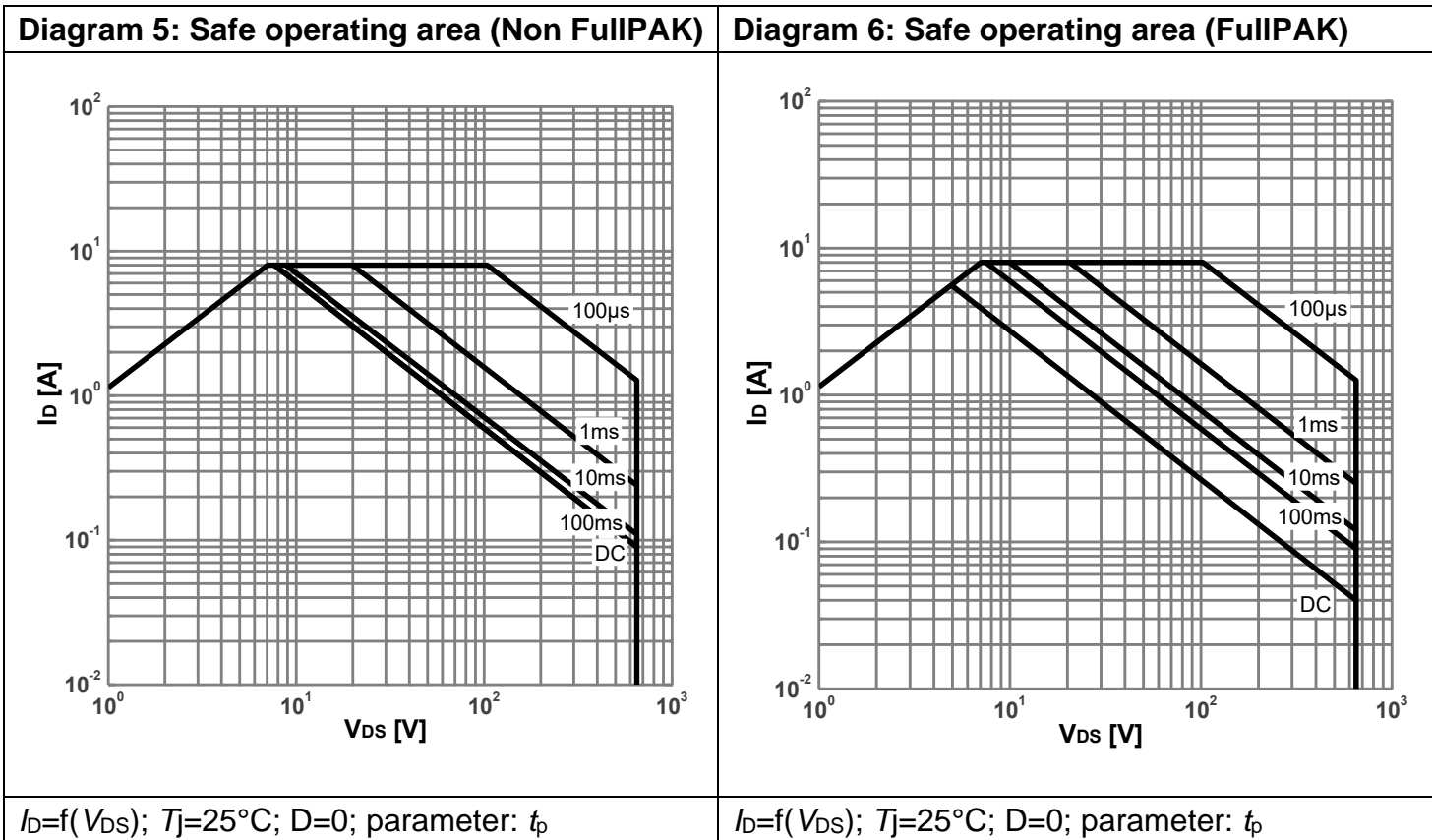

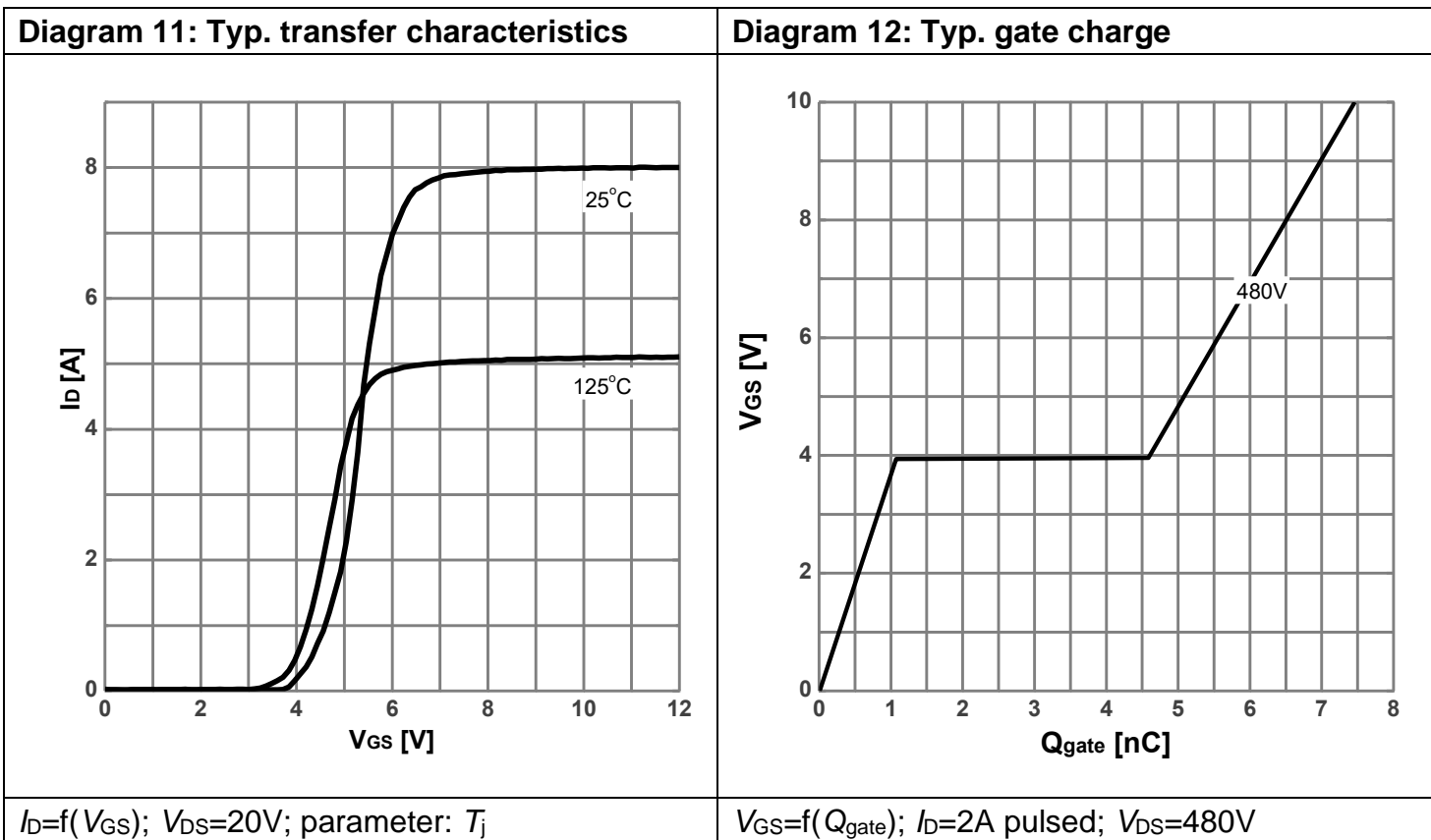
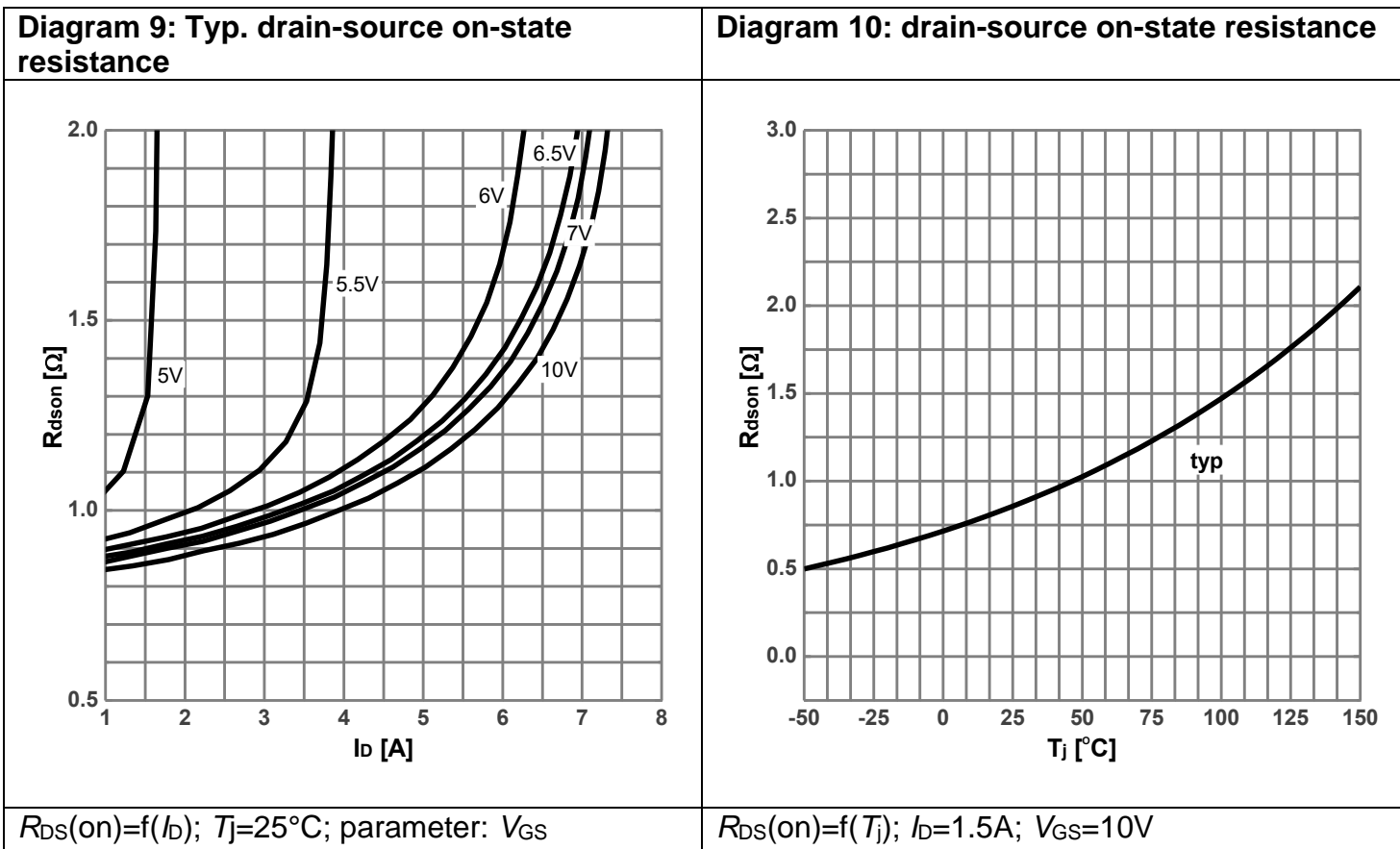

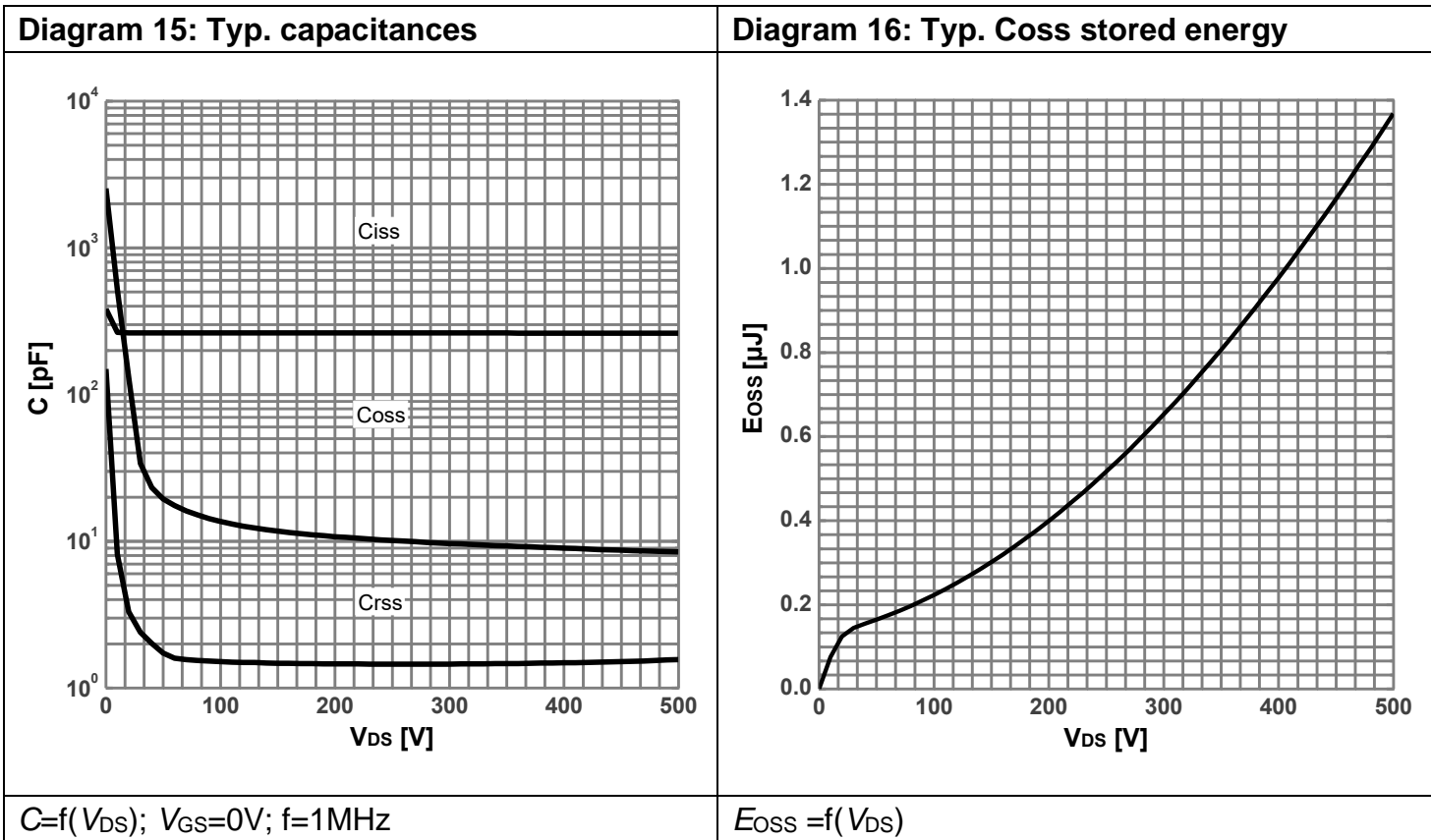
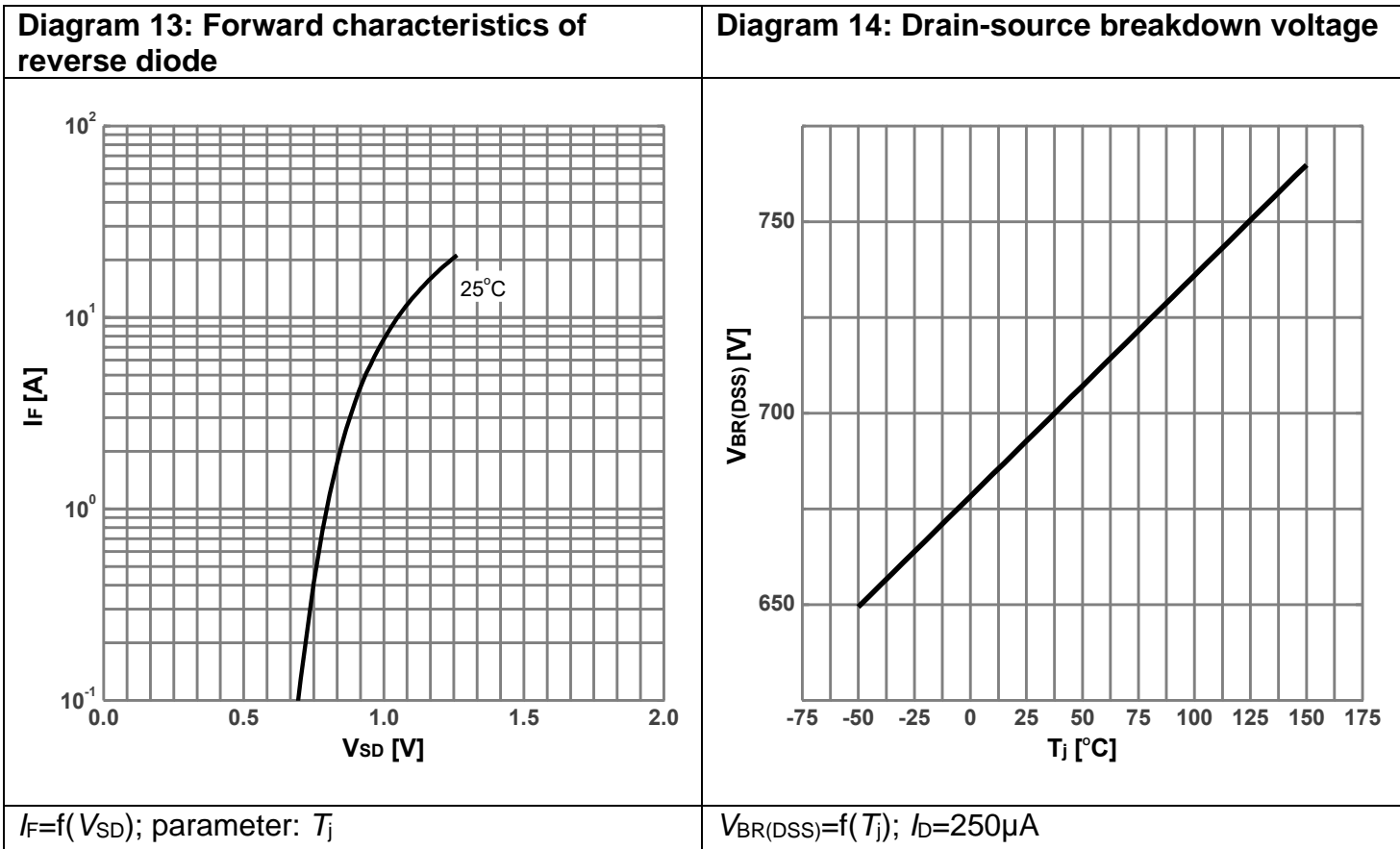

6. Test Circuits

Table 8. Diode Characteristics

<p>Test circuit for diode characteristics</p>  <p>$R_{g1} = R_{g2}$</p>	<p>Diode recovery waveform</p>  <p>$t_{rr} = t_r + t_s$ $Q_{rr} = Q_r + Q_s$</p>
---	---

Table 9. Switching Times

<p>Switching times test circuit for inductive load</p> 	<p>Switching times waveform</p> 
---	---

Table 10. Unclamped Inductive Load

<p>Unclamped inductive load test circuit</p> 	<p>Unclamped inductive waveform</p> 
--	--

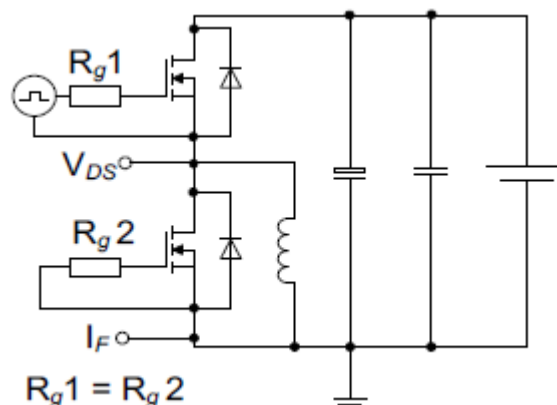
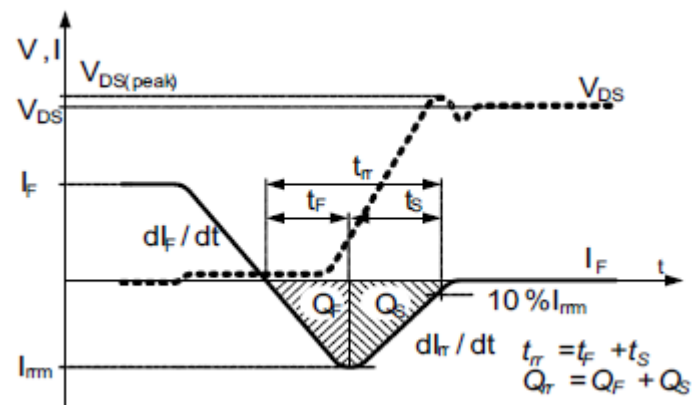
7. Package Outlines

Figure 1 Outline TO-220 Dimensions in mm

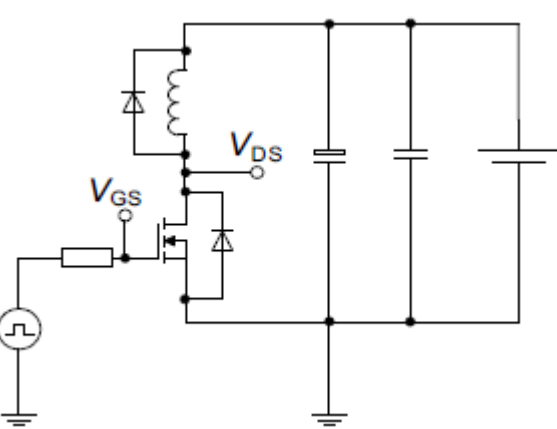
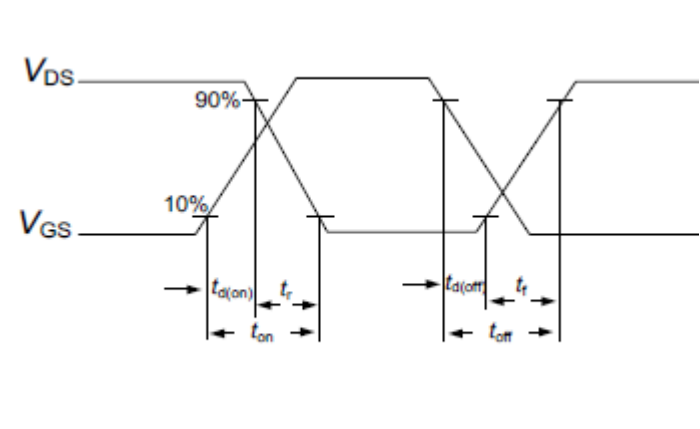
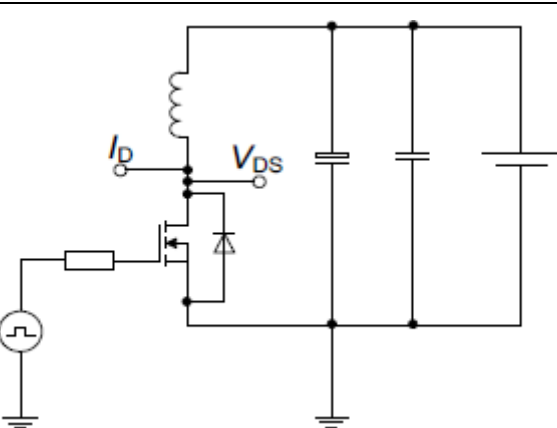
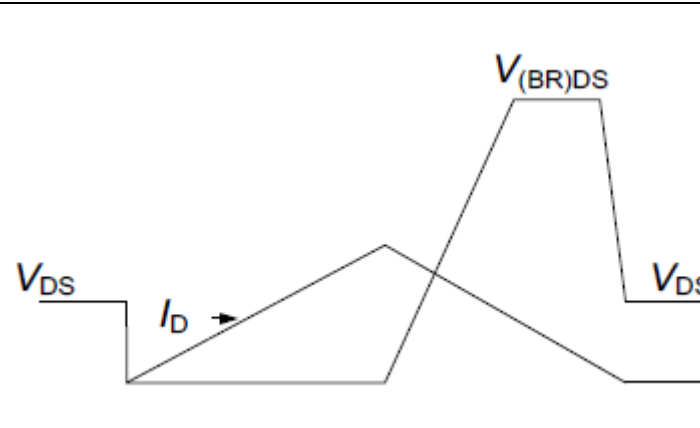
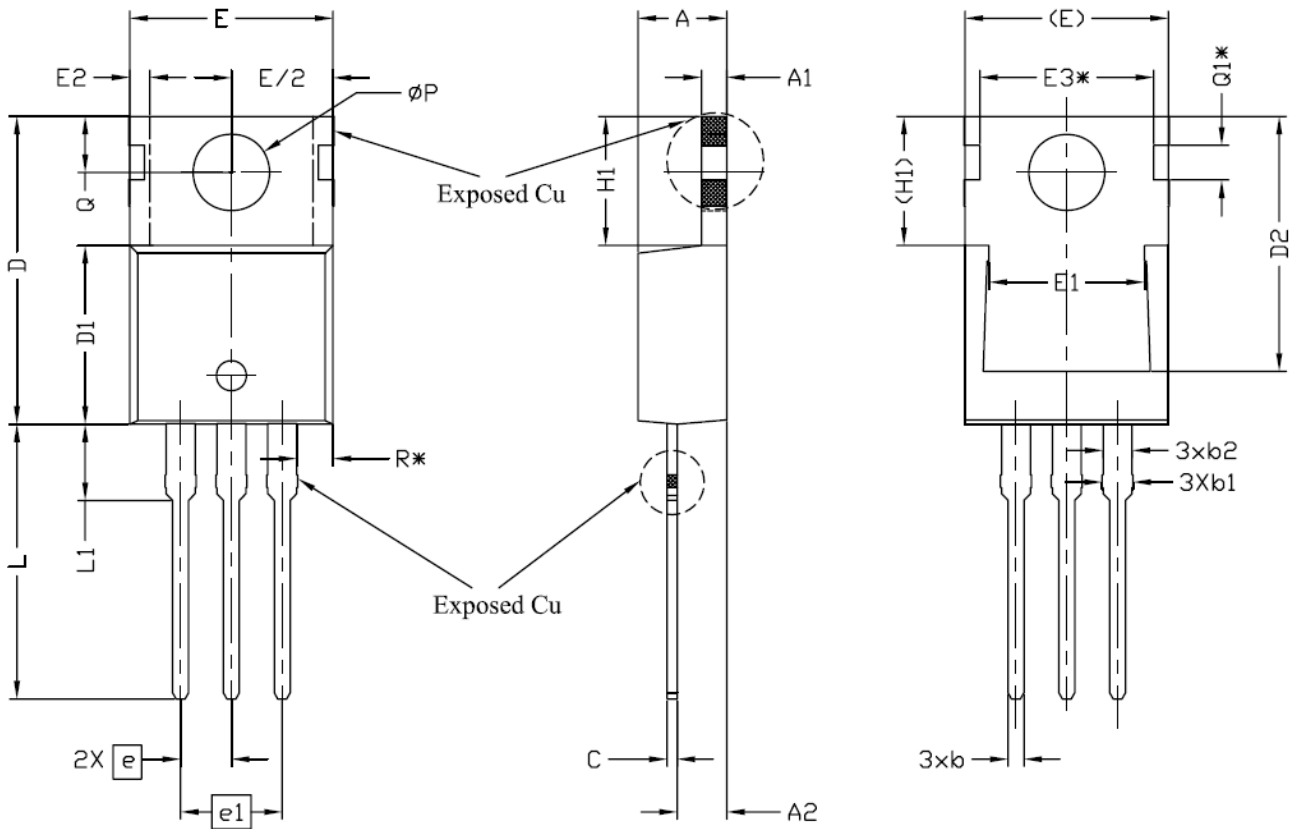

SYMBOL	DIMENSIONS			NOTES
	MIN.	NOM.	MAX.	
A	4.24	4.44	4.64	
A1	1.15	1.27	1.40	
A2	2.30	2.48	2.70	
b	0.70	0.80	0.90	
b1	1.20	1.55	1.75	
b2	1.20	1.45	1.70	
c	0.40	0.50	0.60	
D	14.70	15.37	16.00	4
D1	8.82	8.92	9.02	
D2	12.43	12.73	12.83	5
E	9.96	10.16	10.36	4,5
E1	6.86	7.77	8.89	5
E2	-	-	0.76	6
E3*	8.70REF.			
e	2.54BSC			
e1	5.08BSC			
H1	6.30	6.45	6.60	5,6
L	13.47	13.72	13.97	
L1	3.60	3.80	4.00	
ØP	3.75	3.84	3.93	
Q	2.60	2.80	3.00	
Q1*	1.73REF.			
R*	1.82REF.			

Note:

1. Package Reference: JEDEC TO220, Variation AB.
2. All Dimensions Are In mm.
3. Slot Required, Notch May Be Rounded
4. Dimension D & E Do Not Include Mold Flash. Mold Flash Shall Not Exceed 0.127mm Pre Side. These Dimensions Are Measured At The Outermost Extreme Of The Plastic Body.
5. Thermal Pad Contour Optional Within Dimensions E, H1, D2 & E1.
6. Dimension E2 & H1 Define A Zone Where Stamping And Singulation Irregularities Are Allowed.
7. "*" is reference .

Figure 2 Outline TO-251 Dimensions in mm

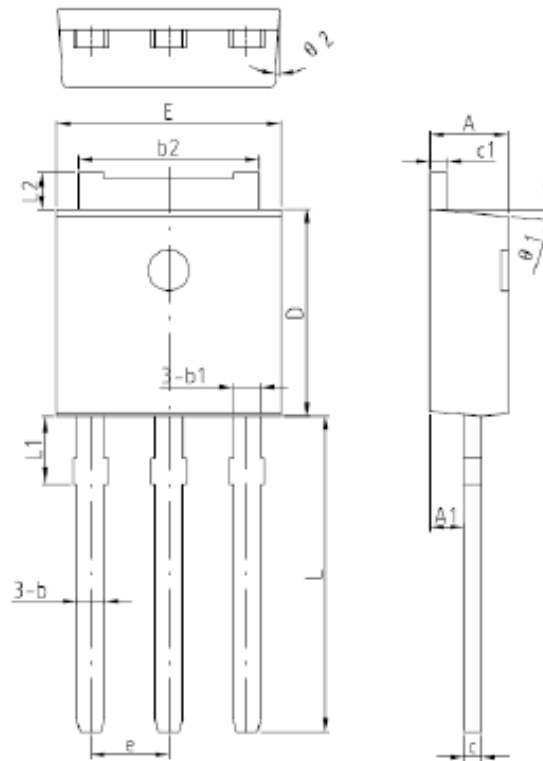

Symbol	Dimensions(mm)		
	Min.	Typ.	Max.
A	2.20	2.30	2.40
A1	0.90	1.01	1.17
b	0.50	-	0.91
b1	-	0.81	-
b2	5.13	5.33	5.46
c	0.46	0.50	0.60
c1	0.46	0.50	0.60
D	5.95	6.10	6.25
E	6.45	6.60	6.75
e	2.286(BSC)		
L	9.00	9.30	9.60
L1	-	2.00	-
L2	0.90	-	1.25
θ_1	-	5°	-
θ_2	-	3°	-

Figure 3 Outline TO-252 Dimensions in mm

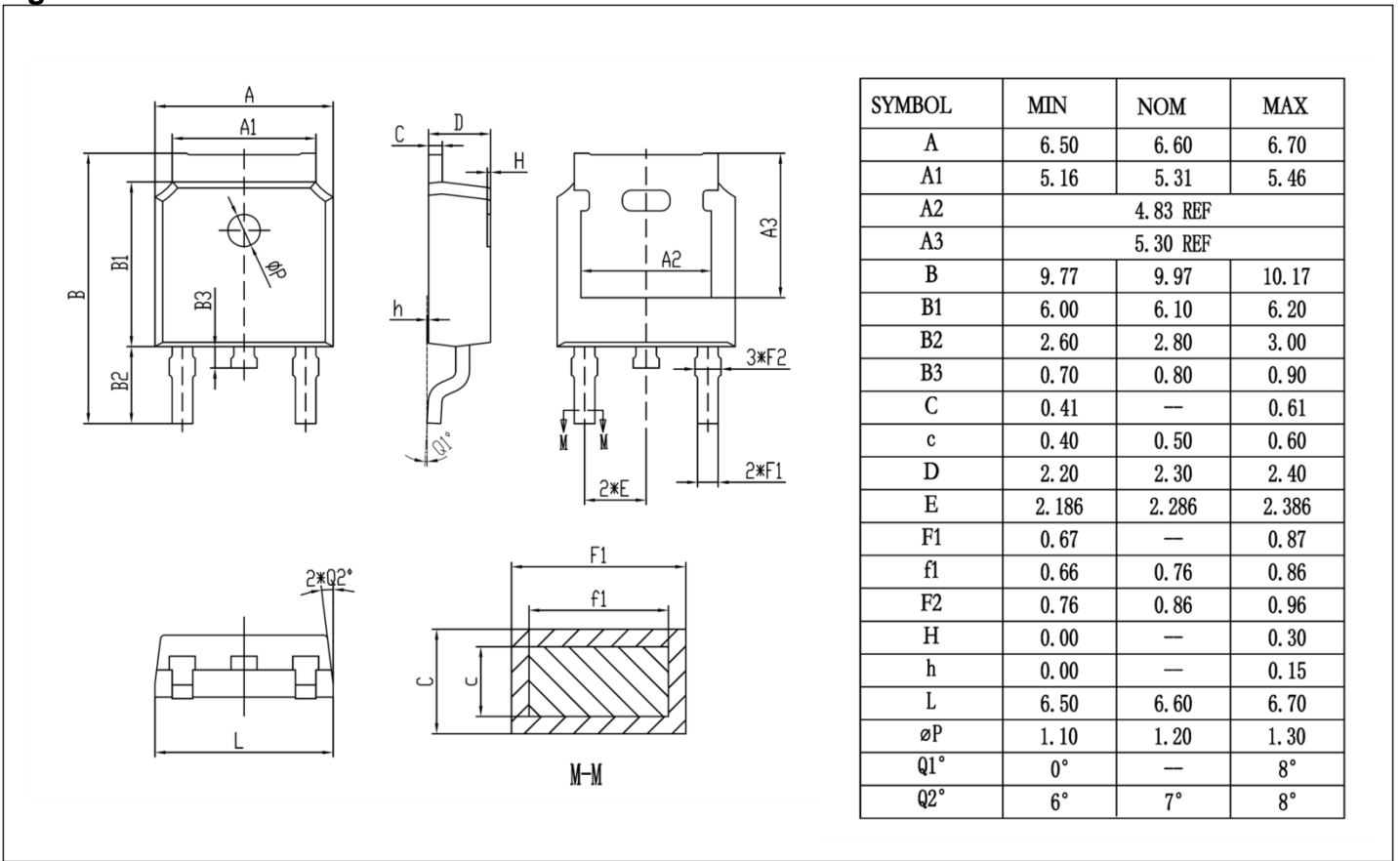
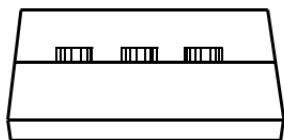
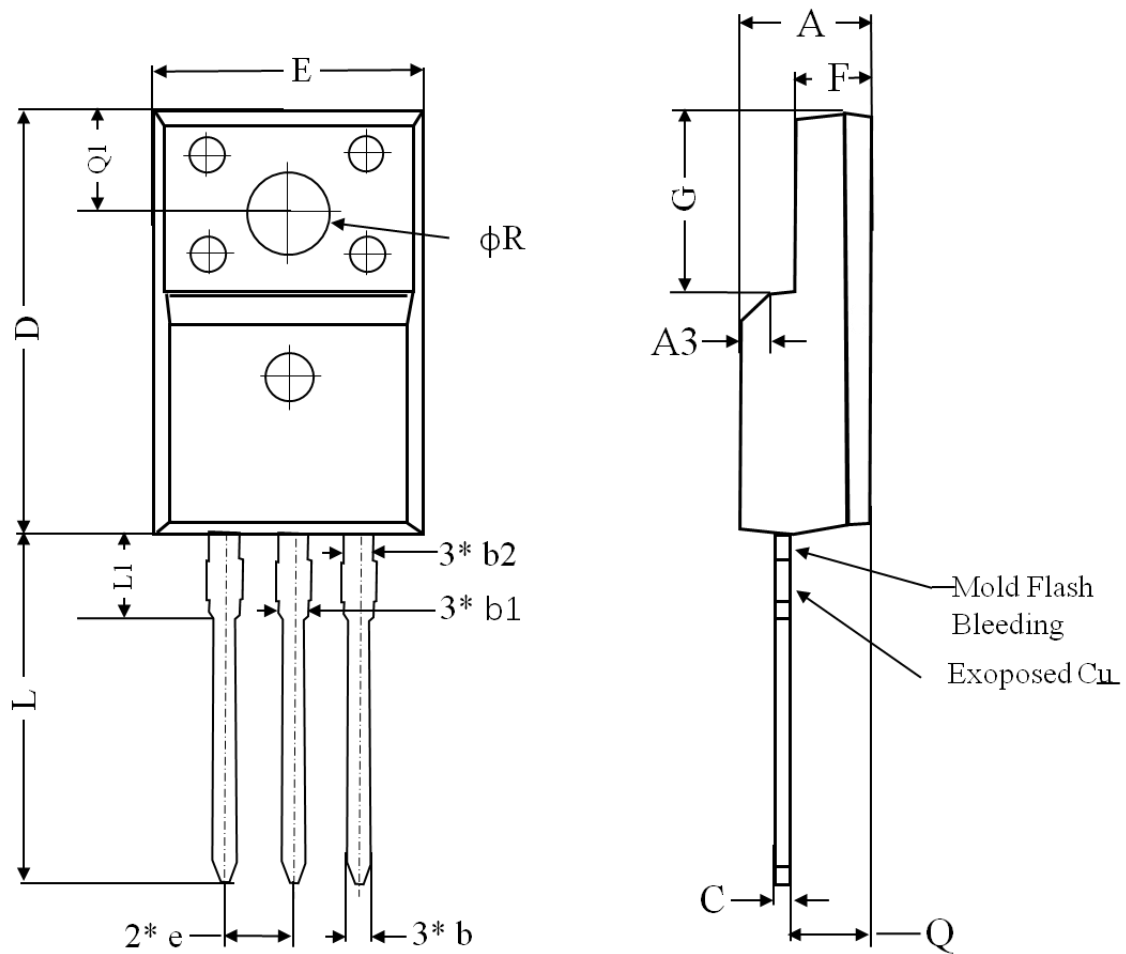

Figure 4 Outline TO-220 FullPAK Dimensions in mm



Note:

1. All Dimension Are In mm.
2. Package Body Sizes Exclude Mold Flash And Burrs Mold Flash Should Be less Than 6 Mil.

SYMBOL	DIMENSIONS		
	Min.	Nom.	Max.
A	4.60	4.70	4.80
b	0.70	0.80	0.91
b1	1.20	1.30	1.47
b2	1.10	1.20	1.30
C	0.45	0.50	0.63
D	15.80	15.87	15.97
e	2.54		
E	10.00	10.10	10.30
F	2.44	2.54	2.64
G	6.50	6.70	6.90
L	12.90	13.10	13.30
L1	3.13	3.23	3.33
Q	2.65	2.75	2.85
Q1	3.20	3.30	3.40
Φr	3.08	3.18	3.28

8. Appendix

CoolSemi Webpage: www.coolsemi.com.

单击下面可查看定价，库存，交付和生命周期等信息

[>>CoolSemi](#)