

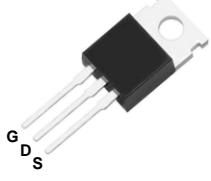

N-channel 1200V, 650mΩ typ.,
 Super Junction MOSFET G1 in TO-220, TO-263, TO-247 and TO-220F

Datasheet - production data

1. Descriptions

TO-220	TO-263
	
TO-247	TO-220F
	
N-Channel MOSFET	
 <p>POWER MOSFET</p>	

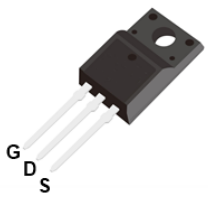
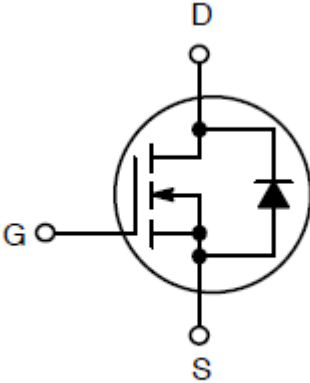
Key Performance Parameters

Parameters	Value	Unit
BV_{DSS}	1200	V
$R_{DS(on),max}$	690	mΩ
$Q_{g,typ}$	62	nC
$I_{D,pulse}$	36	A
E_{AS}	1225	mJ

Features

- Ultra-fast body diode.
- Extremely low losses due to very low FOM $R_{dson} * Q_g$ and E_{oss} .
- Very high commutation ruggedness.
- Qualified for industrial grade applications according to JEDEC.

Applications

- PC power.
- Server power supply.
- Telecom.
- LED lighting.
- EV Charger.
- Solar/UPS.

Type/Ordering Code	Package	Marking	Related Links
CPP120R690G1	TO-220	120R690G1	See Appendix A
CPB120R690G1	TO-263	120R690G1	
CPW120R690G1	TO-247	120R690G1	
CPA120R690G1	TO-220F	120R690G1	

Contents

1.	Descriptions	1
2.	Maximum Ratings	3
3.	Thermal Characteristics	4
4.	Electrical Characteristics	5
5.	Electrical Characteristics Diagrams	7
6.	Test Circuits	12
7.	Package Outlines	13
8.	Appendix	17

2. Maximum Ratings

at $T_j = 25^\circ\text{C}$, unless otherwise specified

Table 1. Absolute Maximum Ratings

Symbol	Parameter	Values			Unit	Test Condition
		Min.	Typ.	Max.		
V_{DS}	Drain-source voltage ¹⁾	-	-	1200	V	$V_{GS}=0V, I_D=250\mu A$
I_D	Continuous drain current ²⁾	-	-	12 7.7	A	$T_C=25^\circ\text{C}$ $T_C=100^\circ\text{C}$
$I_{D,pulse}$	Pulsed drain current	-	-	36	A	$T_C=25^\circ\text{C}$
E_{AS}	Avalanche energy, single pulse ³⁾	-	-	1225	mJ	$I_D=7A; V_{DD}=50V$
I_{AR}	Avalanche current, repetitive	-	-	7	A	-
dv/dt	MOSFET dv/dt ruggedness	-	-	50	V/ns	$V_{DS}=0\dots 520V$
V_{GS}	Gate source voltage	-30	-	30	V	static; AC ($f > 1\text{ Hz}$)
P_{tot}	Power dissipation (Non FullPAK) TO-220, TO-263, TO-247	-	-	227	W	$T_C=25^\circ\text{C}$
P_{tot}	Power dissipation (FullPAK) TO-220F	-	-	34	W	$T_C=25^\circ\text{C}$
T_j, T_{stg}	Operating and storage temperature	-55	-	150	$^\circ\text{C}$	-
I_S	Continuous diode forward current	-	-	12	A	$T_C=25^\circ\text{C}$
$I_{S,pulse}$	Diode pulse current ²⁾	-	-	36	A	$T_C=25^\circ\text{C}$
dv/dt	Reverse diode dv/dt ⁴⁾	-	-	50	V/ns	$V_{DS}=0\dots 400V, I_{SD} \leq I_S, T_j=25^\circ\text{C}$

1) Limited by T_j max. Maximum duty cycle $D=0.75$.

2) Pulse width t_p limited by T_j, max .

3) $V_{DD}=50V, R_G=25\Omega$, Starting $T_j=25^\circ\text{C}$.

4) $V_{DClk}=600V; V_{DS,peak} < V_{(BR)DSS}$; identical low side and high side switch with identical R_G .

3. Thermal Characteristics

Table 2. Thermal Characteristics (Non FullPAK) TO-220, TO-263, TO-247

Symbol	Parameter	Values			Unit	Test Condition
		Min.	Typ.	Max.		
R_{thJC}	Thermal resistance, junction - case	-	-	0.55	°C/W	$T_C = 25^\circ\text{C}$
R_{thJA}	Thermal resistance, junction - ambient	-	-	62	°C/W	$T_C = 25^\circ\text{C}$
T_{sold}	Soldering temperature, wavesoldering only allowed at leads	-	-	260	°C	Lead Temperature (Soldering, 10 sec)

Table 3. Thermal Characteristics (FullPAK) TO-220F

Symbol	Parameter	Values			Unit	Test Condition
		Min.	Typ.	Max.		
R_{thJC}	Thermal resistance, junction - case	-	-	3.67	°C/W	$T_C = 25^\circ\text{C}$
R_{thJA}	Thermal resistance, junction - ambient	-	-	62.5	°C/W	$T_C = 25^\circ\text{C}$
T_{sold}	Soldering temperature, wavesoldering only allowed at leads	-	-	260	°C	Lead Temperature (Soldering, 10 sec)

4. Electrical Characteristics

at $T_j = 25^\circ\text{C}$, unless otherwise specified

Table 4. Static Characteristics

Symbol	Parameter	Values			Unit	Test Condition
		Min.	Typ.	Max.		
$V_{(BR)DSS}$	Drain-source breakdown voltage	1200	-	-	V	$V_{GS}=0V, I_D=250\mu A$
$V_{(GS)th}$	Gate threshold voltage	3.0	-	5.0	V	$V_{DS}=V_{GS}, I_D=250\mu A$
I_{DSS}	Zero gate voltage drain current	-	-	10	μA	$V_{DS}=1200V, V_{GS}=0V, T_j=25^\circ C$
I_{GSS}	Gate-source leakage current	-	-	± 100	nA	$V_{GS}=\pm 30V, V_{DS}=0V$
$R_{DS(on)}$	Drain-source on-state resistance	-	650	690	m Ω	$V_{GS}=10V, I_D=6A, T_j=25^\circ C$
R_G	Gate resistance	-	3.5	-	Ω	$V_{DD}=0V, V_{GS}=0V, F=1MHz$

Table 5. Dynamic Characteristics

Symbol	Parameter	Values			Unit	Test Condition
		Min.	Typ.	Max.		
C_{iss}	Input capacitance	-	3190	-	pF	$V_{GS}=0V, V_{DS}=100V, f=1MHz$
C_{oss}	Output capacitance	-	65	-	pF	$V_{GS}=0V, V_{DS}=100V, f=1MHz$
C_{riss}	Reverse transfer capacitance	-	1.8	-	pF	$V_{GS}=0V, V_{DS}=100V, f=1MHz$
$C_{o(er)}$	Effective output capacitance, energy related ¹⁾	-	44	-	pF	$V_{GS}=0V, V_{DS}=0$ to 600V
$C_{o(tr)}$	Effective output capacitance, time related ²⁾	-	123	-	pF	$V_{GS}=0V, V_{DS}=0$ to 600V
$t_{d(on)}$	Turn-on delay time	-	20	-	ns	$V_{DD}=600V, V_{GS}=10V, I_D=6A$
t_r	Rise time	-	8	-	ns	$V_{DD}=600V, V_{GS}=10V, I_D=6A$
$t_{d(off)}$	Turn-off delay time	-	55	-	ns	$V_{DD}=600V, V_{GS}=10V, I_D=6A$
t_f	Fall time	-	14	-	ns	$V_{DD}=600V, V_{GS}=10V, I_D=6A$

Table 6. Gate Charge Characteristics

Symbol	Parameter	Values			Unit	Test Condition
		Min.	Typ.	Max.		
Q_{gs}	Gate to source charge	-	20	-	nC	$V_{DD}=600V, I_D=6A, V_{GS}=0$ to 10V
Q_{gd}	Gate to drain charge	-	26	-	nC	$V_{DD}=600V, I_D=6A, V_{GS}=0$ to 10V
Q_g	Gate charge total	-	62	-	nC	$V_{DD}=600V, I_D=6A, V_{GS}=0$ to 10V
$V_{plateau}$	Gate plateau voltage	-	7	-	V	$V_{DD}=600V, I_D=6A, V_{GS}=0$ to 10V

1) $C_{o(er)}$ is a fixed capacitance that gives the same stored energy as C_{oss} while V_{DS} is rising from 0 to 600V.

2) $C_{o(tr)}$ is a fixed capacitance that gives the same charging time as C_{oss} while V_{DS} is rising from 0 to 600V.

Table 7. Reverse Diode Characteristics

Symbol	Parameter	Values			Unit	Test Condition
		Min.	Typ.	Max.		
V_{SD}	Diode forward voltage	-	0.8	-	V	$V_{GS}=0V, I_F=6A, T_i=25^{\circ}C$
t_{rr}	Reverse recovery time	-	550	-	ns	$V_R=60V, I_F=6A, di_F/dt=100A/\mu s$
Q_{rr}	Reverse recovery charge	-	10.1	-	μC	$V_R=60V, I_F=6A, di_F/dt=100A/\mu s$
I_{rrm}	Peak reverse recovery current	-	32	-	A	$V_R=60V, I_F=6A, di_F/dt=100A/\mu s$

5. Electrical Characteristics Diagrams

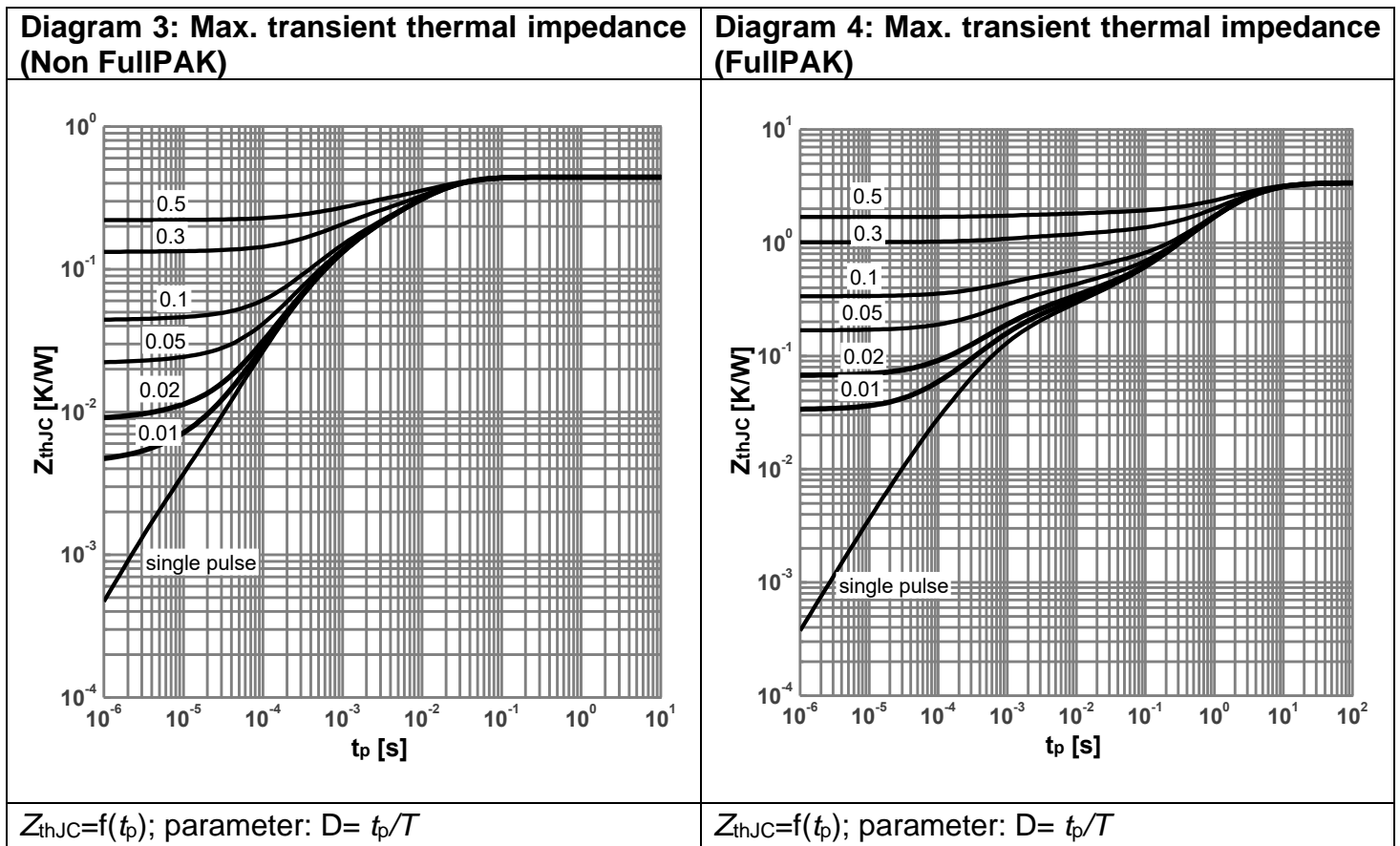
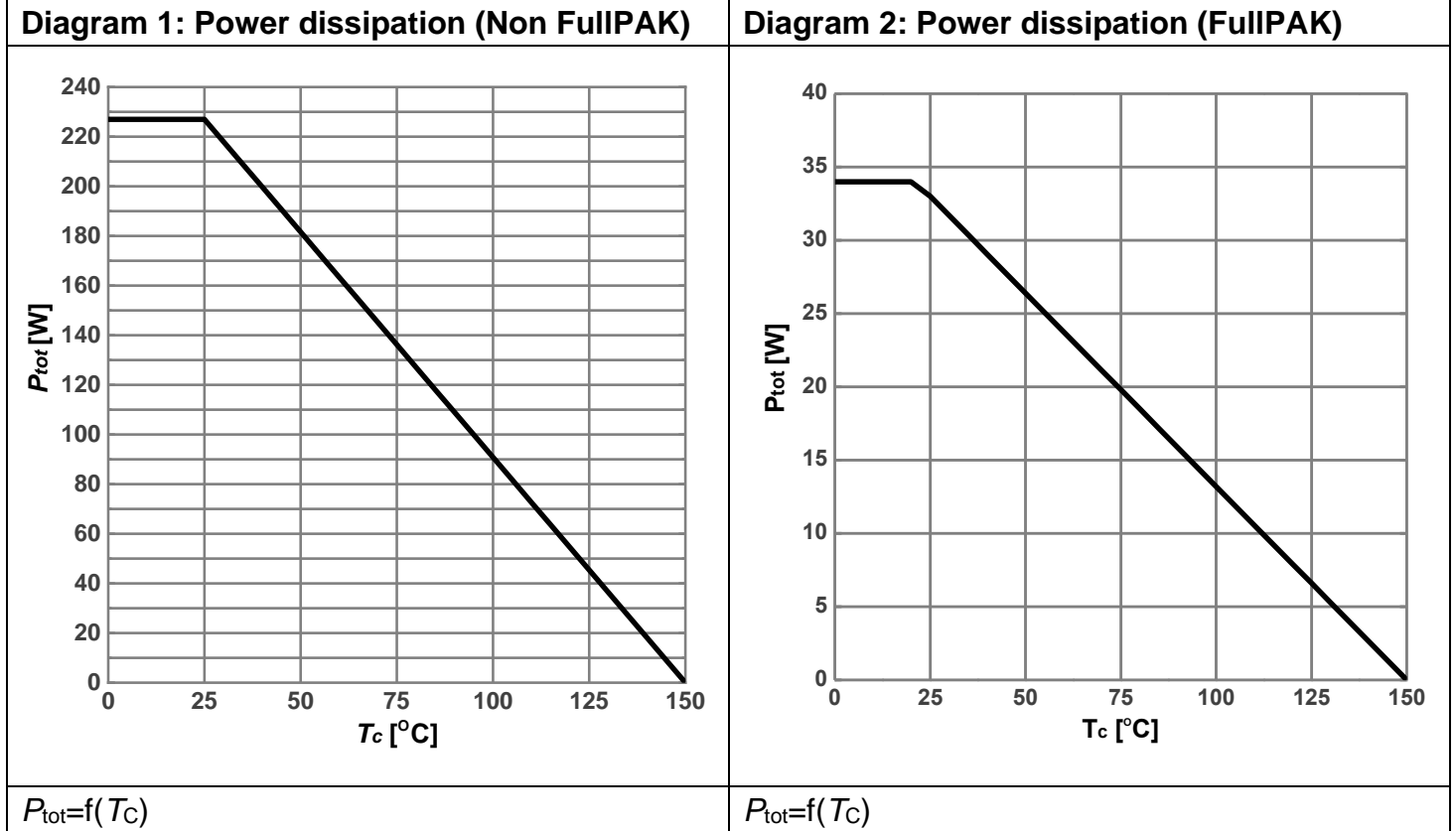

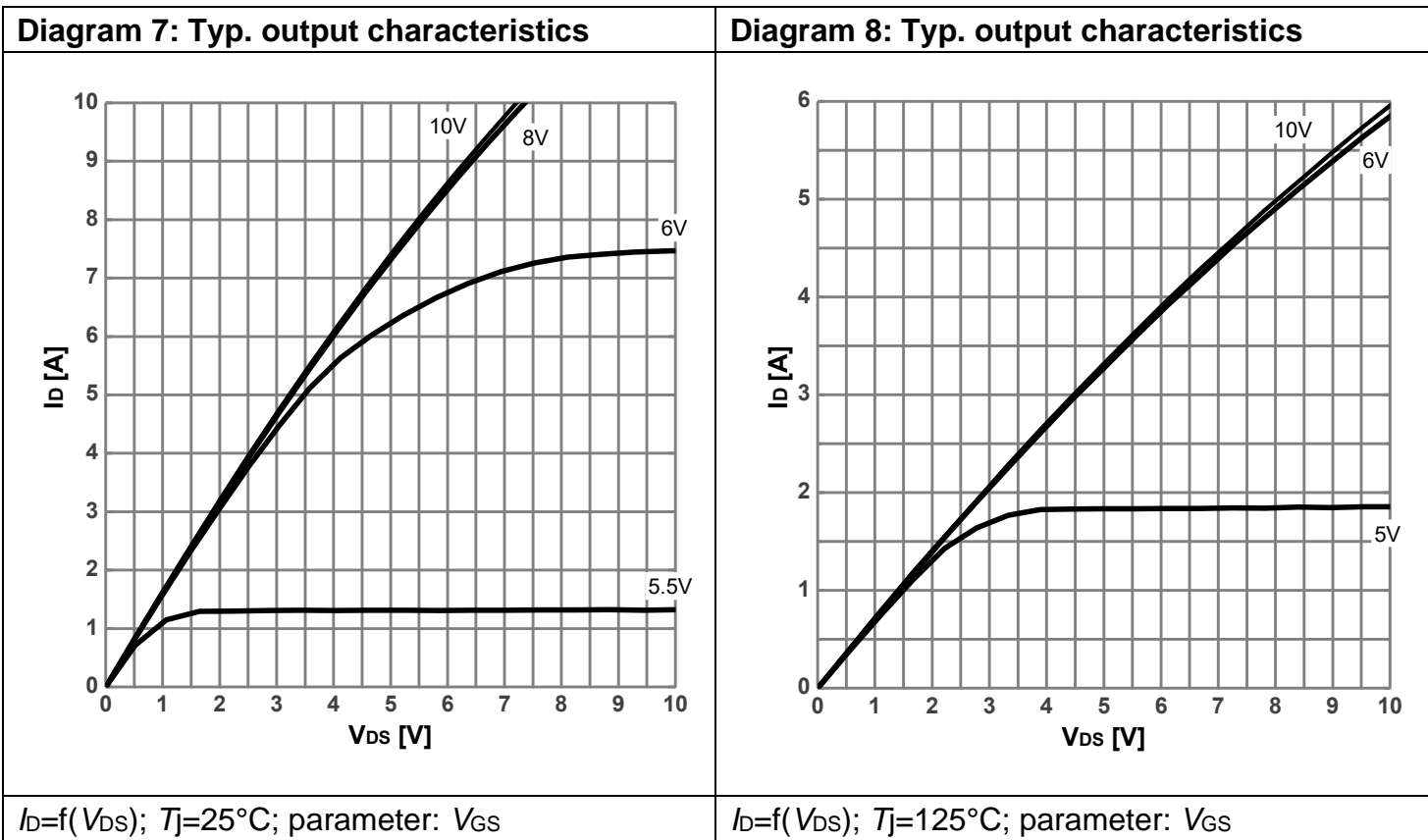
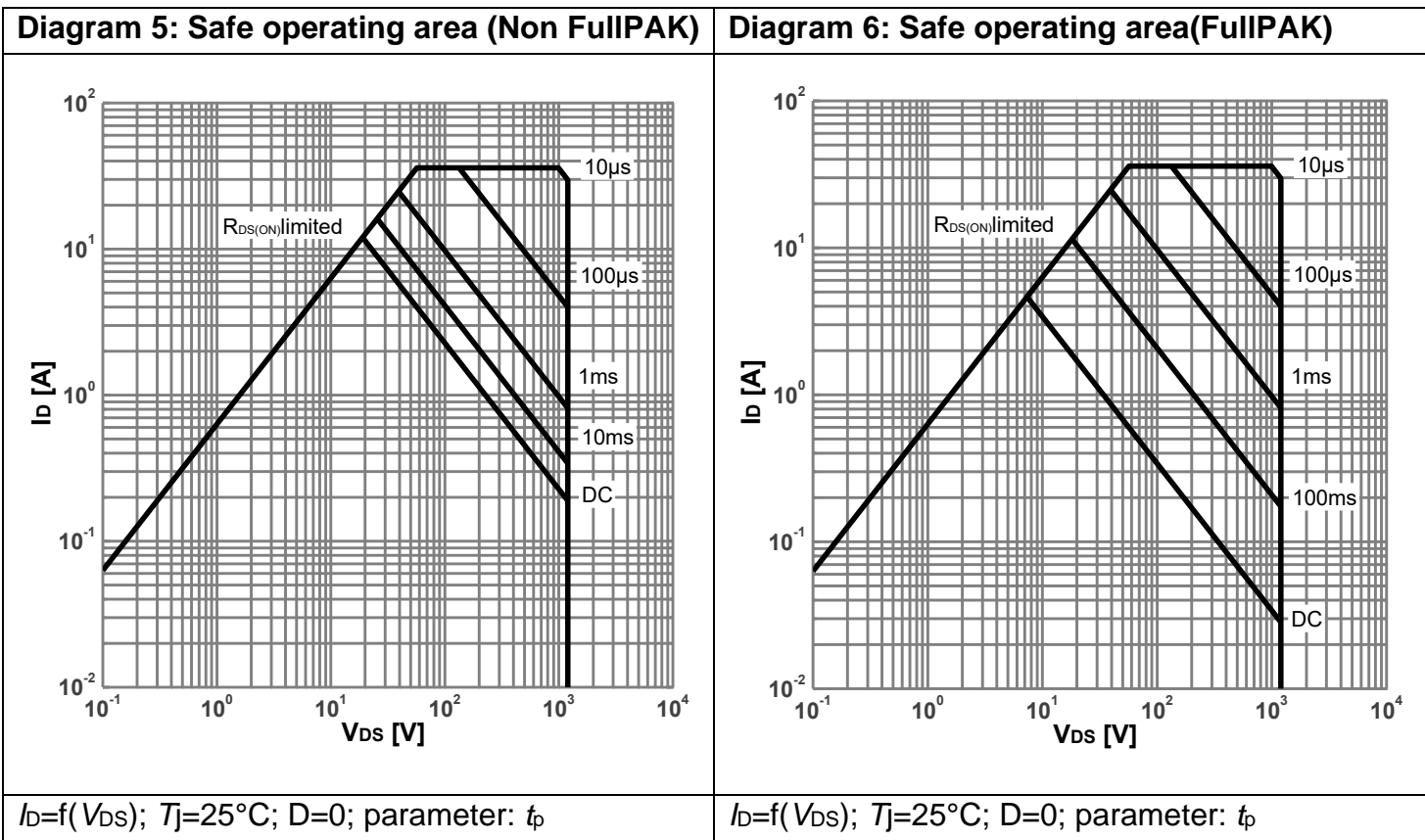
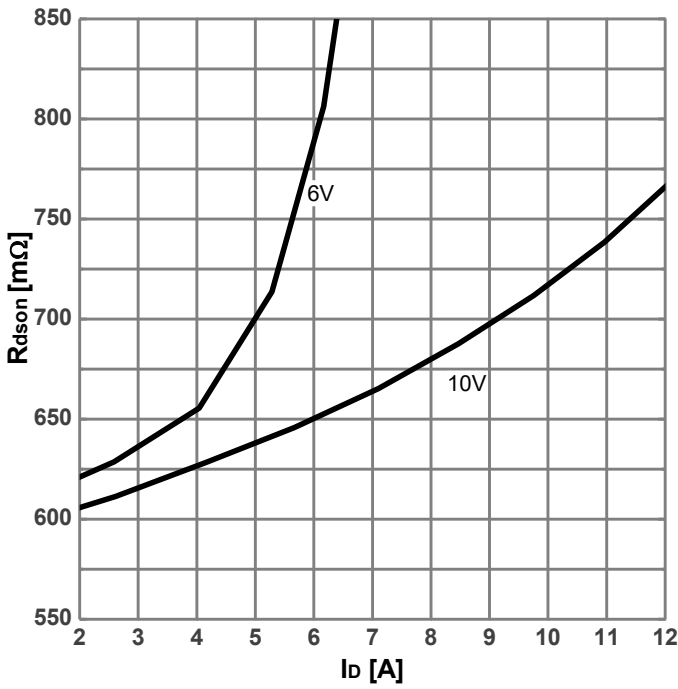
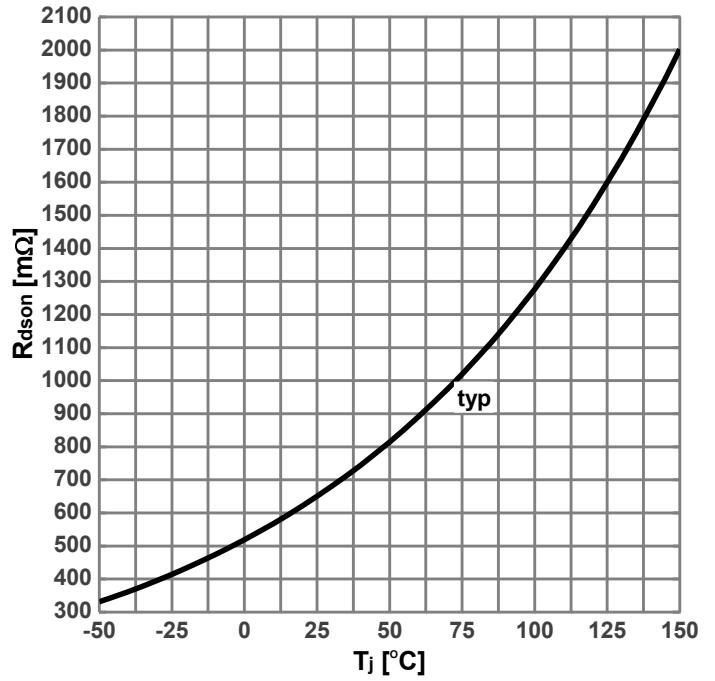

Diagram 9: Typ. drain-source on-state resistance



$R_{DS(on)}=f(I_D)$; $T_j=25^\circ C$; parameter: V_{GS}

Diagram 10: Drain-source on-state resistance



$R_{DS(on)}=f(T_j)$; $I_D=6A$; $V_{GS}=10V$

Diagram 11: Typ. transfer characteristics

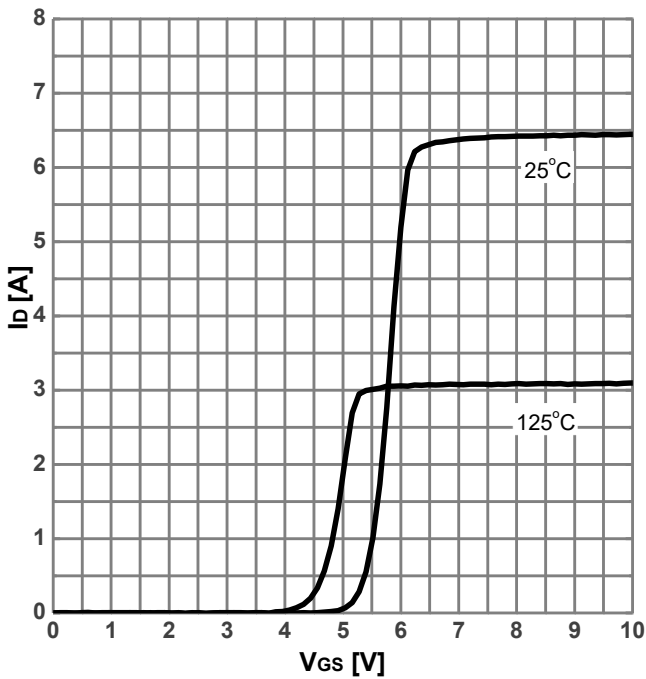

$I_D=f(V_{GS})$; $V_{DS}=20V$; parameter: T_j

Diagram 12: Typ. gate charge

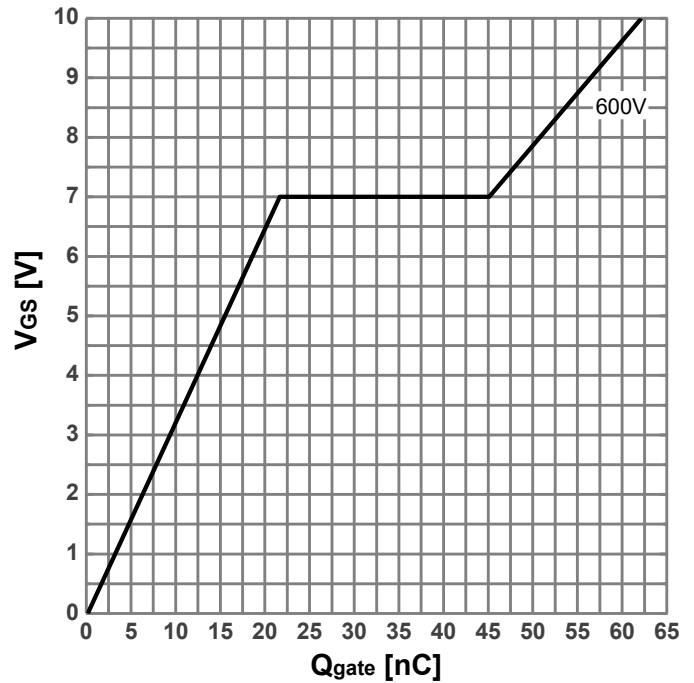

$V_{GS}=f(Q_{gate})$; $I_D=6A$ pulsed; $V_{DS}=600V$

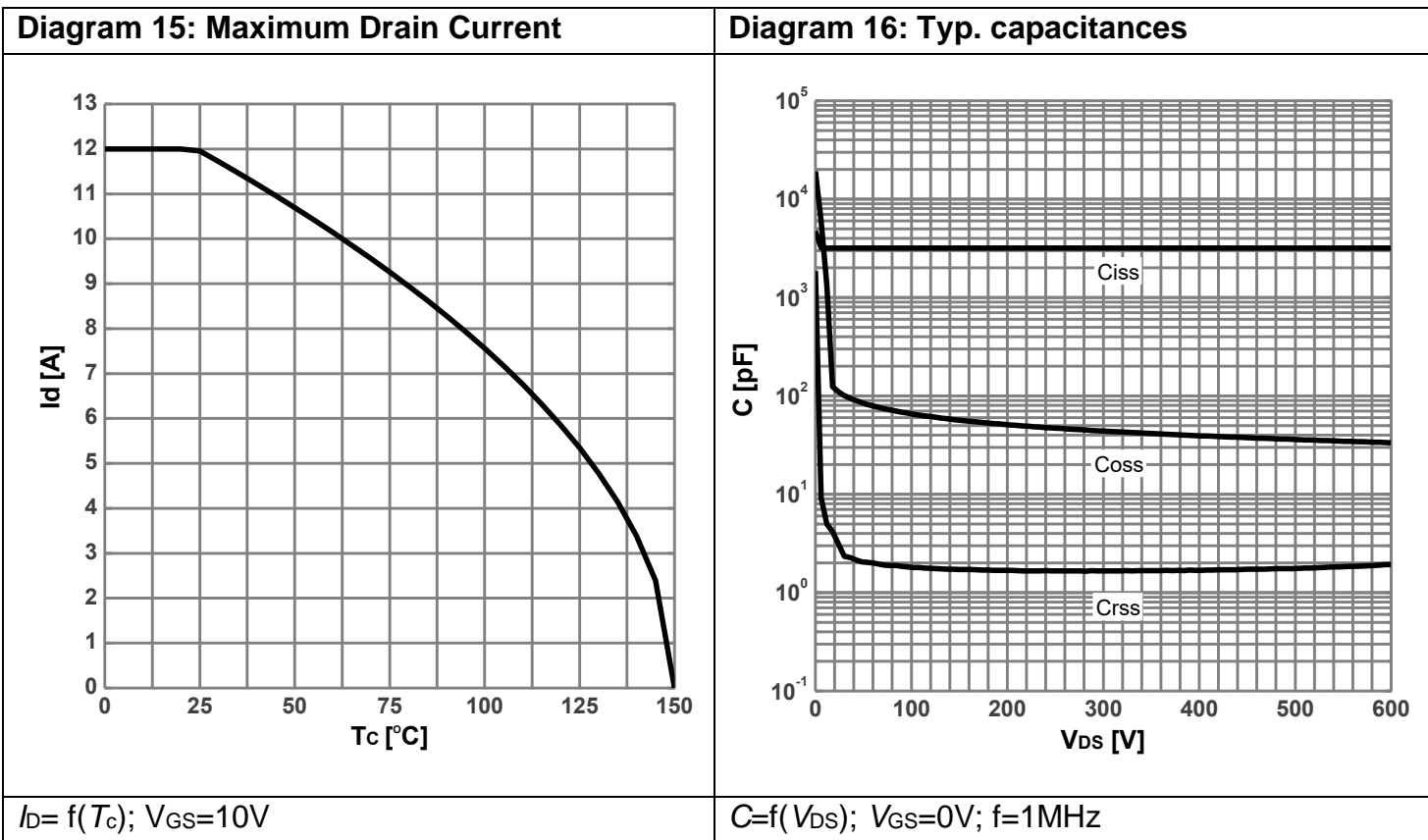
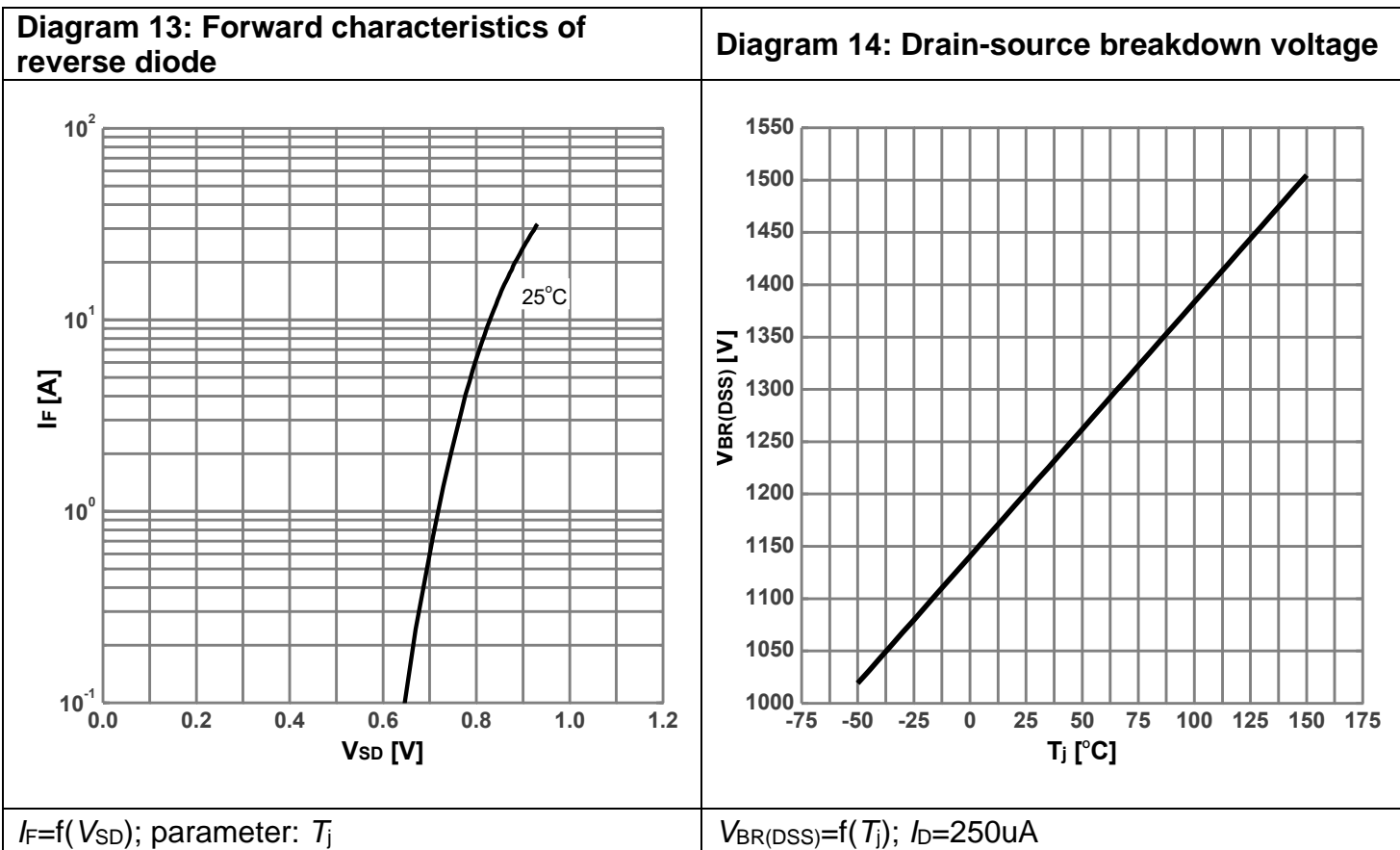
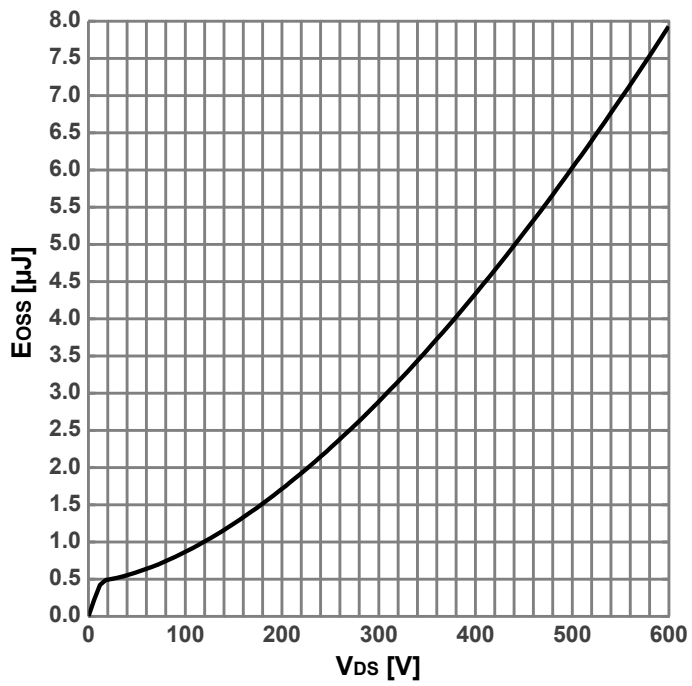

Diagram 17: Typ. Coss stored energy



$$E_{oss} = f(V_{DS})$$

6. Test Circuits

Table 8. Diode Characteristics

<p>Test circuit for diode characteristics</p>  <p>$R_{g1} = R_{g2}$</p>	<p>Diode recovery waveform</p>  <p>$t_{rr} = t_F + t_S$ $Q_{tr} = Q_F + Q_S$</p>
---	---

Table 9. Switching Times

<p>Switching times test circuit for inductive load</p> 	<p>Switching times waveform</p> 
---	---

Table 10. Unclamped Inductive Load

<p>Unclamped inductive load test circuit</p> 	<p>Unclamped inductive waveform</p> 
--	--

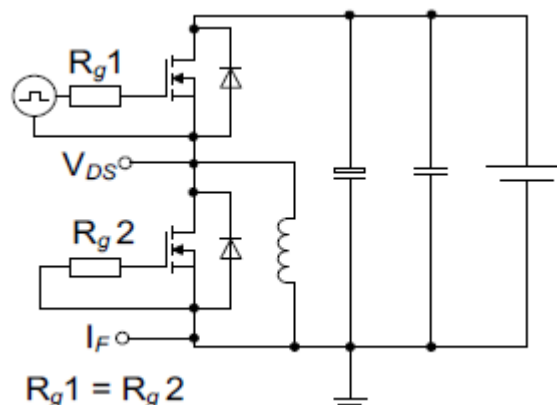
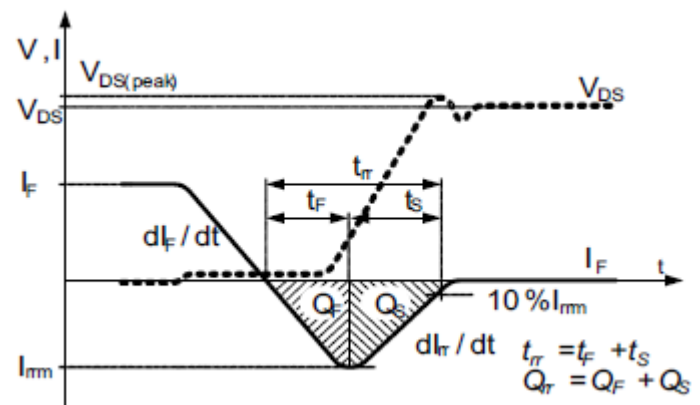
7. Package Outlines

Figure 1 Outline TO-220 Dimensions in mm

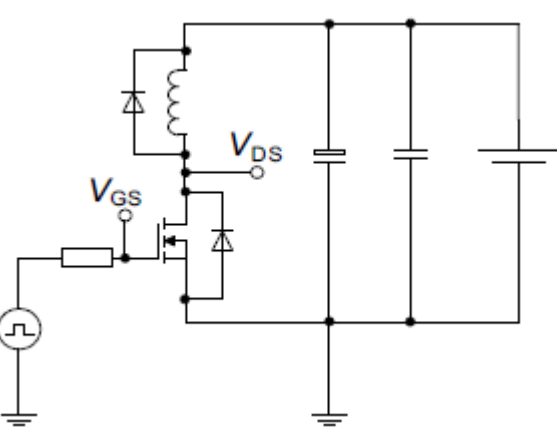
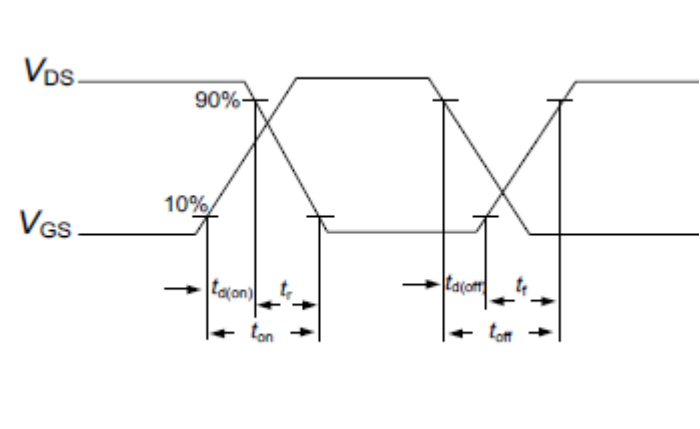
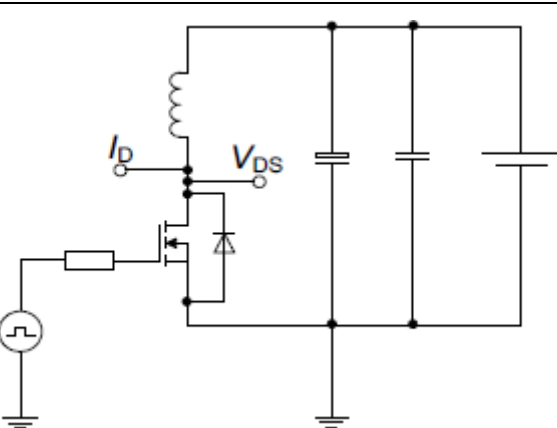
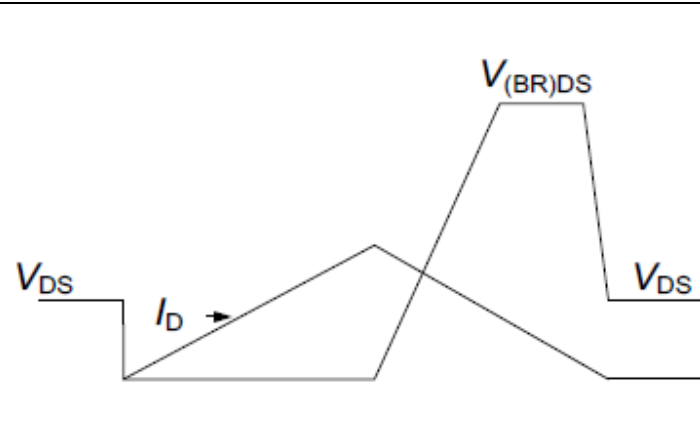
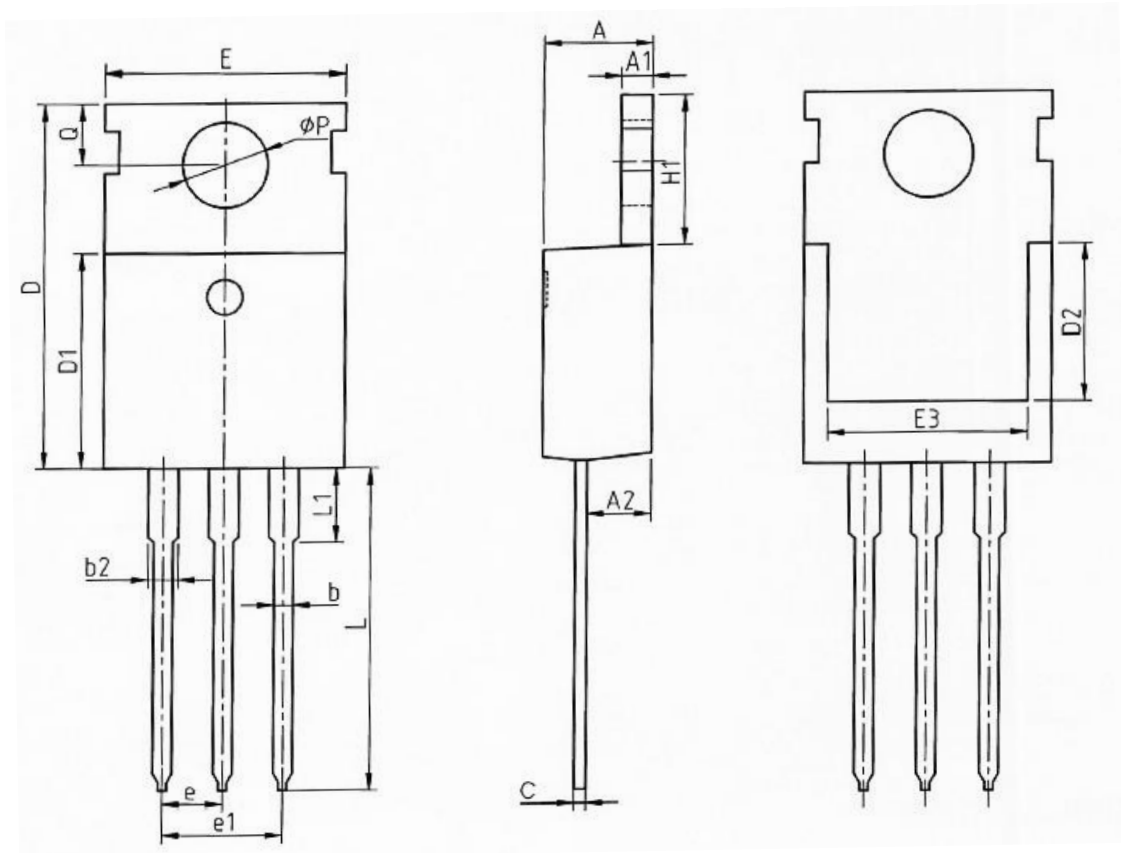

Dimensions In Millimeters		
Symbol	Min	Max
A	4.37	4.70
A1	1.25	1.40
A2	2.20	2.60
b	0.70	0.95
b2	1.17	1.47
c	0.45	0.60
D	15.10	16.10
D1	8.80	9.40
D2	5.50	-
E	9.70	10.30
E3	7.00	-
e	2.54BSC	
e1	5.08BSC	
H1	6.25	6.85
L	12.75	13.80
L1	-	3.40
ØP	3.40	3.80
Q	2.60	3.00

Figure 2 Outline TO-263 Dimensions in mm

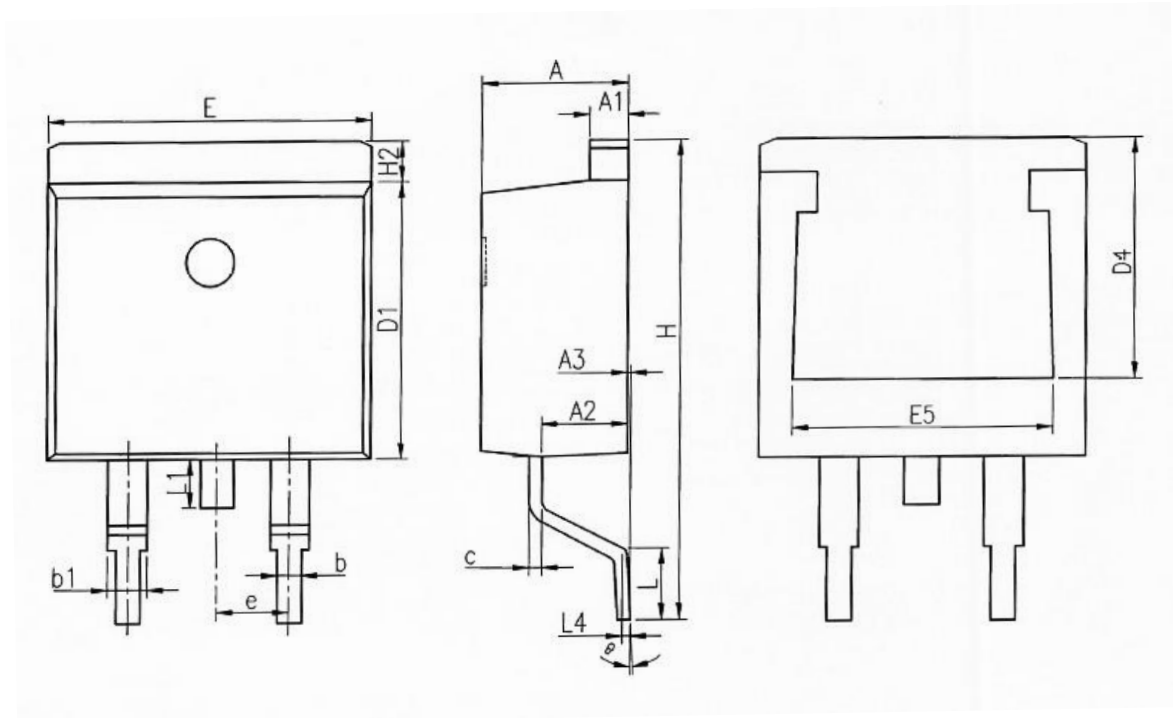

Dimensions In Millimeters		
Symbol	Min	Max
A	4.37	4.77
A1	1.22	1.42
A2	2.49	2.89
A3	0.00	0.25
b	0.70	0.96
b1	1.17	1.47
c	0.30	0.53
D1	8.50	8.90
D4	6.60	-
E	9.86	10.36
E5	7.06	-
c	2.54BSC	
H	14.70	15.50
H2	1.07	1.47
L	2.00	2.60
L1	1.40	1.70
L4	0.25BSC	
θ	0°	9°

Figure 3 Outline TO-247 Dimensions in mm

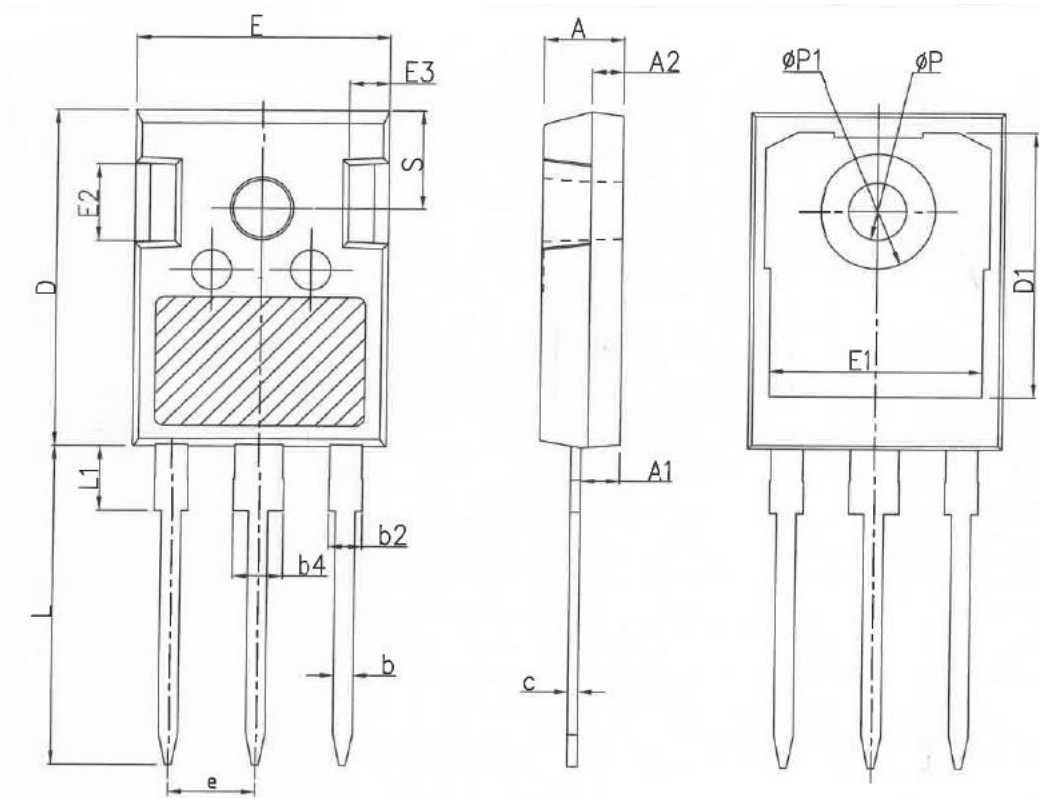

Dimensions In Millimeters		
Symbol	Min	Max
A	4.80	5.20
A1	2.21	2.59
A2	1.85	2.15
b	1.11	1.36
b2	1.91	2.21
b4	2.91	3.21
c	0.51	0.75
D	20.70	21.30
D1	16.25	16.85
E	15.50	16.10
E1	13.00	13.60
E2	4.80	5.20
E3	2.30	2.70
e	5.44BSC	
L	19.62	20.22
L1	-	4.30
ΦP	3.40	3.80
ΦP1	-	7.30
S	6.15BSC	

Figure 4 Outline TO-220 FullPAK Dimensions in mm

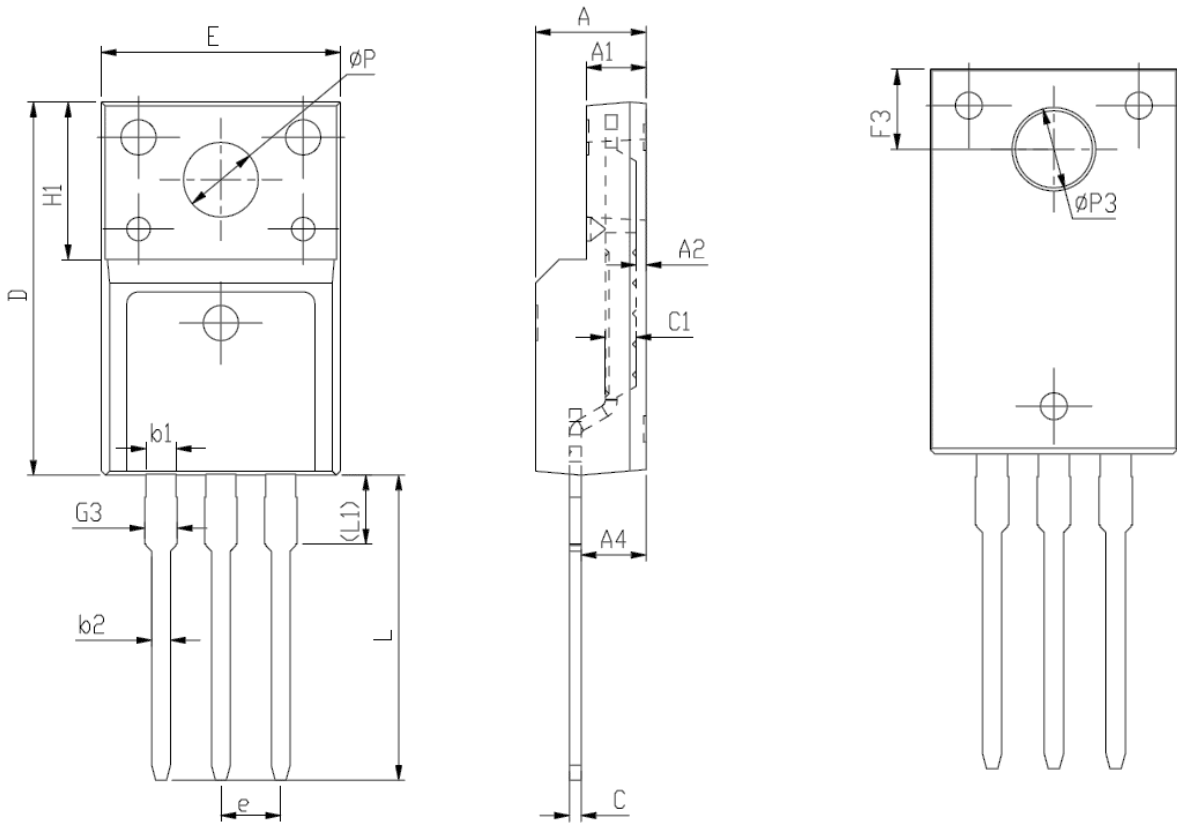

Dimensions In Millimeters		
Symbol	Min	Max
E	9.96	10.36
A	4.50	4.90
A1	2.34	2.74
A2	0.30	0.60
A4	2.56	2.96
c	0.40	0.65
c1	1.20	1.35
D	15.57	16.17
H1	6.70REF	
e	2.54BSC	
L	12.68	13.28
L1	3.03	3.43
ΦP	3.03	3.38
ΦP3	3.15	3.65
F3	3.15	3.45
G3	1.25	1.55
b1	1.18	1.43
b2	0.70	0.95

8. Appendix

CoolSemi Webpage: www.coolsemi.com.

单击下面可查看定价，库存，交付和生命周期等信息

[>>CoolSemi](#)