



Cosemitech

CH913/CH913L

Automotive Product Group

This is advanced information on a new product now in development or undergoing evaluation. Details are subject to change without notice and Cosemitech assumes no obligation for future manufacture of this product. Contact Cosemitech for the latest status.

Preliminary Datasheet 1.8

FEATURES and FUNCTIONAL DIAGRAM

- Micro-power Omnipolar-Switch Hall Sensor
- Multiple Sensitivity Options (BOP / BRP): ±35 / ±25 Gauss;
- Open Drain output ability
- Chopper stabilized design provides:
 - Superior temperature stability
 - Minimal switch point drift
 - Enhanced immunity to physical stress
- On board voltage regulator for 1.8V to 5.5V range
- Open Drain Output (1 mA Sink)
- Solid-state reliability
- Wide Operating temperature range: -40 to 150 °C
- Small package sizes TO-92S, SOT-23
- RoHS-compliant material meets directive 2011/65/EU

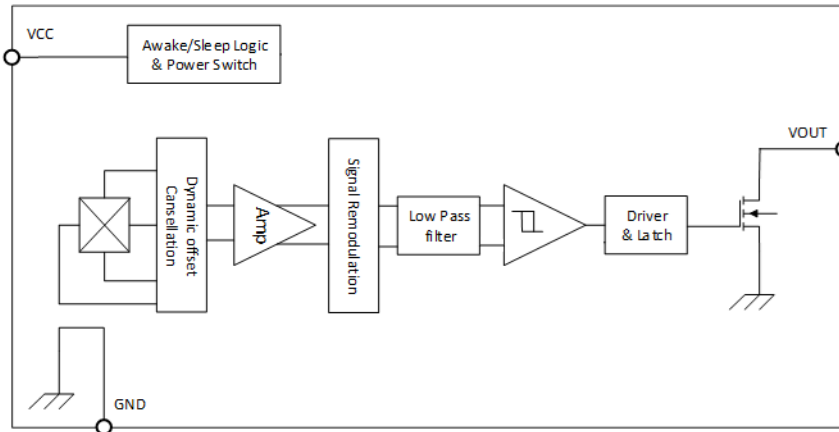

PACKAGE

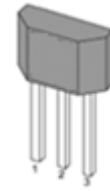

TO-92S

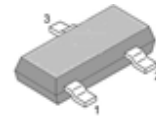

SOT-23-3L

APPLICATIONS

- Open and Close Detect for Flip/Slide Cellular Phones;
- Smart Cover or Dock Detect for Cellular Phones and Tablet PCs;
- Cover or Display Switch in Portable PCs (eg: Ultrabook);
- Digital Still, Video Cameras and Handheld Gaming Consoles;
- Door, Lids and Tray Position Switches;
- Level, Proximity and Position Switches;
- Contact-Less Switches in Home Appliances and Industrial Applications.

DESCRIPTION

The CH913/CH913L is a high-sensitivity extremely temperature-stable micro-power Omnipolar Hall effect switch IC with internal pull down capability. Designed for portable and battery powered consumer equipment such as cellular phones and portable PCs to office equipment, home appliances and industrial applications, the average supply current is only 1.62µA at 3.3V for CH913 and 0.92µA at 3.3V for CH913L. To support portable equipment the CH913/CH913L can operate over the supply range of 1.8V to 5.5V and uses a hibernating clocking system to minimize the power consumption.

The device includes a clocking system, a Hall-voltage generator, a small-signal amplifier, a chopper stabilization, two Schmitt trigger, and an output driver controller.

The output is activated with either a north or south pole of sufficient magnetic field strength. When the magnetic flux density (B) perpendicular to the package is larger than operate point (Bop), the output will be turned on (pulled low) and held until B is lower than release point (Brp).

Two package styles provide a magnetically optimized package for most applications, SO-T23 and TO-92S. Each package type is lead (Pb) free (suffix, -T), with a 100% matte-tin-plated leadframe.

	Cosemitech	CH913/CH913L
	Automotive Product Group	<small>This is advanced information on a new product now in development or undergoing evaluation. Details are subject to change without notice and Cosemitech assumes no obligation for future manufacture of this product. Contact Cosemitech for the latest status.</small>

Preliminary Datasheet 1.8

Table of Contents

1. Product Family Members		3
2. Pin Definitions and Descriptions		3
3. Absolute Maximum Ratings		3
4. ESD Protections		4
5. Function Description		4
6. Magnetic Activation		4
7. Temperature Characterization		6
8. Parameters Specification		6
9. Application information		7
10. Package Information		10

	Cosemitech	CH913/CH913L
	Automotive Product Group	<small>This is advanced information on a new product now in development or undergoing evaluation. Details are subject to change without notice and Cosemitech assumes no obligation for future manufacture of this product. Contact Cosemitech for the latest status.</small>

Preliminary Datasheet 1.8

1. Product Family Members

Part Number	Marking ID	Description
CH913SR	C913	Micro-power Omnipolar-Switch, Hall-effect digital sensor IC, SOT-23-3L package, tape and reel packing (3000 units per reel)
CH913TB	C913	Micro-power Omnipolar-Switch, Hall-effect digital sensor IC, flat, TO-92S package, bulk packing (1000 units per bag)
CH913LSR	913L	Micro-power Omnipolar-Switch, Hall-effect digital sensor IC, SOT-23-3L package, tape and reel packing (3000 units per reel)
CH913LTB	913L	Micro-power Omnipolar-Switch, Hall-effect digital sensor IC, flat, TO-92S package, bulk packing (1000 units per bag)

2. Pin Definitions and Descriptions

SOT-23-3L (S)	TO-92S (T)	Name	Type	Function
1	1	VDD	Supply	Supply Voltage pin
2	3	OUT	Output	Open Drain Output pin
3	2	GND	Ground	Ground pin

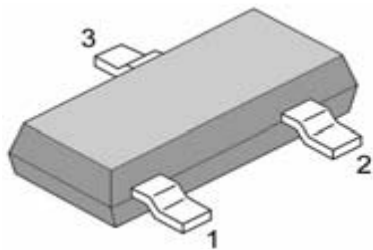

SOT-23-3L

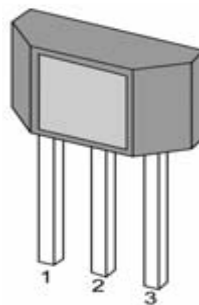

TO-92S

3. Absolute Maximum Ratings

Parameter	Symbol	Min	Max	Units
Supply Voltage	V_{DD}	-	6	V
VDD Reverse Voltage V_{DD}	V_{RDD}	-0.3		V
Supply Current	I_{DD}	-	2	mA
Output Voltage	V_{OUT}	-0.3	$V_{DD}+0.3$	V
Output Current	I_{OUT}	-	3	mA
Operating Ambient Temperature	T_A	-40	150	°C
Storage Temperature	T_S	-50	150	°C
Junction temperature	T_J	-50	165	°C
Magnetic Flux	B	No Limit		Gauss

Note: Exceeding the absolute maximum ratings may cause permanent damage. Exposure to absolute-maximum-rated conditions for extended periods may affect device reliability.

	Cosemitech	CH913/CH913L
	Automotive Product Group	<small>This is advanced information on a new product now in development or undergoing evaluation. Details are subject to change without notice and Cosemitech assumes no obligation for future manufacture of this product. Contact Cosemitech for the latest status.</small>

Preliminary Datasheet 1.8

4. ESD Protections

Parameter	Value	Unit
All pins ¹⁾	+/-8000	V
All pins ²⁾	+/-400	V
All pins ³⁾	+/-750	V

- 1) HBM (Human Body Mode) according to AEC-Q100-002
- 2) MM (Machine Mode) according to AEC-Q100-003
- 3) CDM (charged device mode) according to AEC-Q100-011

5. Function Description

The CH913/CH913L exhibits Micro-power digital Omnipolar switching characteristics. Therefore, it requires only south poles or north poles to operate properly.

When the applied magnetic flux density exceeds the BOP threshold, the chip push-pull output goes low. The output stays low until the field decreases to less than BRP, and then the output goes to high.

A magnetic hysteresis BHYST keeps BOP and BRP separated by a minimal value. This hysteresis prevents output oscillation near the switching point.

6. Magnetic Activation

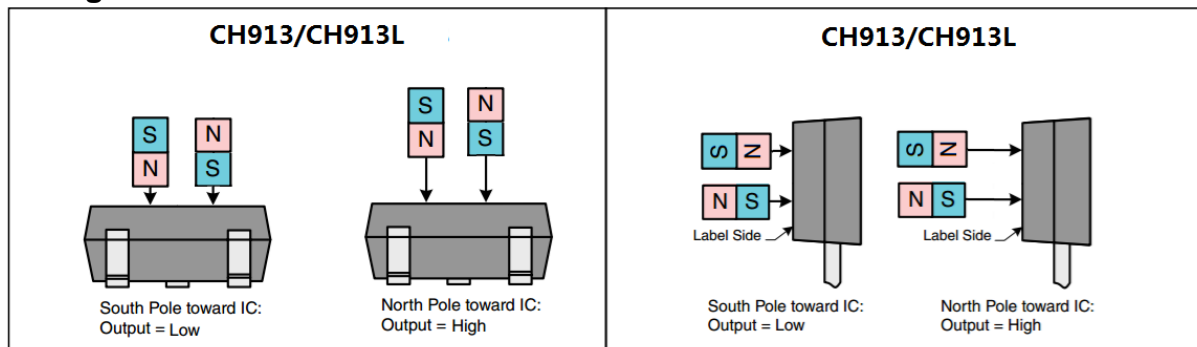

7. Temperature Characteristics

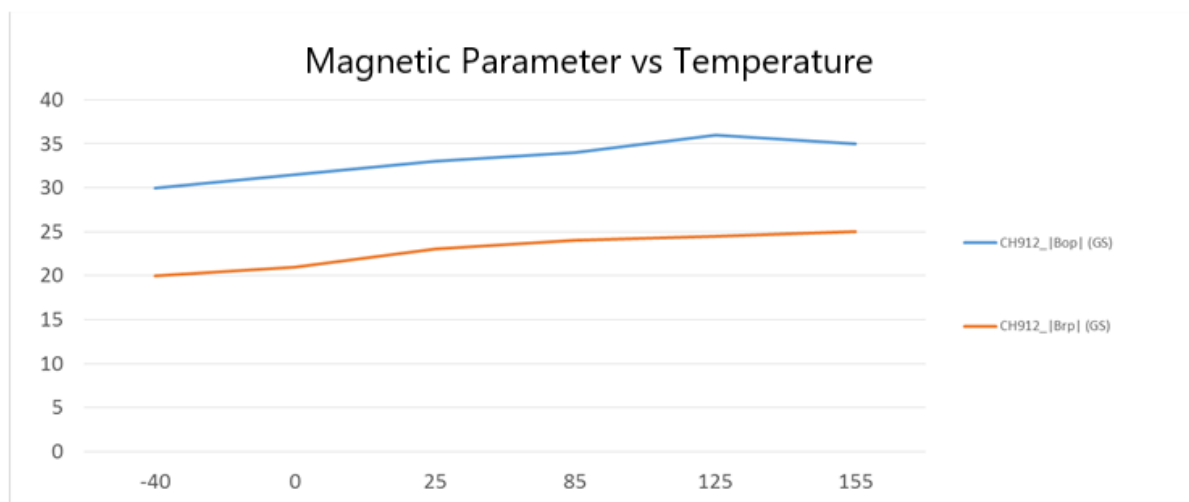

8. Parameters Specification (VCC=3V supply, TA= -40 °C to 150 °C except where otherwise specified.)

Symbol	Characteristic	Test Conditions	Min.	Typ.	Max.	Unit
V _{CC}	Supply Voltage	Operating, T _J < 165°C	1.8		5.25	V
I _{CC(awake)}	CH913 Supply Current	During awake period, TA = 25°C, VCC=3.3V	-	1.1	1.6	mA
	CH913L Supply Current		-	1.1	1.6	mA
I _{CC(sleep)}	CH913 Supply Current	During sleep period, TA = 25°C, VCC=3.3V	-	0.7	-	uA
	CH913L Supply Current		-	0.7	-	uA
I _{CC(avg)}	CH913 Average supply current	TA = 25°C, VDD = 1.8V		1.09		uA
		TA = 25°C, VDD = 3.3V		1.62		uA
	CH913L Average supply current	TA = 25°C, VDD = 1.8V		0.52		uA
		TA = 25°C, VDD = 3.3V		0.92		uA
V _{OL}	Output low voltage(on)	I _{OUT} = 1 mA	-	0.1	0.2	V
V _{OH}	Output high voltage(off)	I _{OUT} = -1mA	V _{CC} -0.2	V _{CC} -0.1	-	V
T _{awake}	CH913 Awake time	(note4)	-	40	60	us
	CH913L Awake time	(note4)	-	40	60	us
T _{period}	CH913 Period	(note4)	-	50	75	ms
	CH913L Period	(note4)	-	190	280	mS
D.C.	Duty cycle CH913	-	-	0.08	-	%
	Duty cycle CH913L	-	-	0.02	-	%
f _c	Chopping Frequency		-	500	-	kHz
I _{OFF}	Output Leakage Current	V _{OUT} = 5.5 V; Switch state = Off	-	-	1	μA
Bop	Operate point	VDD = 1.8V to 5.25V TA = -40°C to 150°C	±20	±35	±55	Gauss
Brp	Release point	VDD = 1.8V to 5.25V TA = -40°C to 150°C	±10	±25	±50	Gauss
Hys	Hysteresis	VDD = 1.8V to 5.25V TA = -40°C to 150°C	-	10	-	Gauss

- 1G (gauss) = 0.1 mT (millitesla).
- Output Rise Time is governed by external circuits tied to VOUT.
- Measured from 10% to 90% of the steady state output.
- When power is initially turned on, the operating VCC (1.8V to 5.5V) must be applied to guaranteed the output sampling. The output state is valid after the second operating cycle (typical 100ms).

NOTICE: The magnetic field strength (Gauss) required to cause the switch to change state (operate and release) will be as specified in the magnetic characteristics. To test the switch against the specified magnetic characteristics, the switch must be placed in a uniform magnetic field.

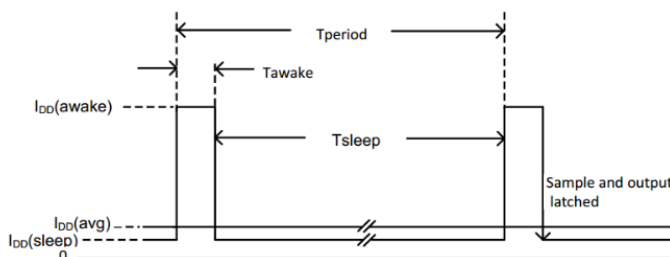

9. Application Information

9.1 Typical Application

It is recommended that an external capacitor C_{IN} is connected to the supply. This can reduce the noise injected into the device. Normal 0.1 μ F is suggested.

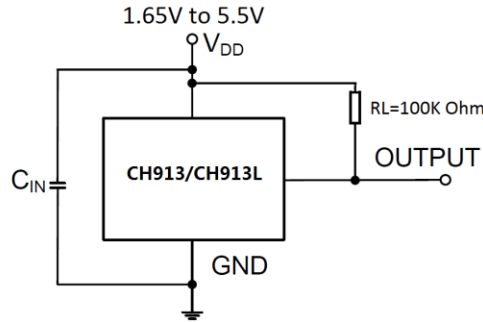

Typical Application Circuit

9.2 Device Output

If the device is powered on with a magnetic field strength between BRP and BOP, then the device output is indeterminate and can either be high or Low. If the field strength is greater than BOP, then the output is pulled low. If the field strength is less than BRP, then the output is pulled high.

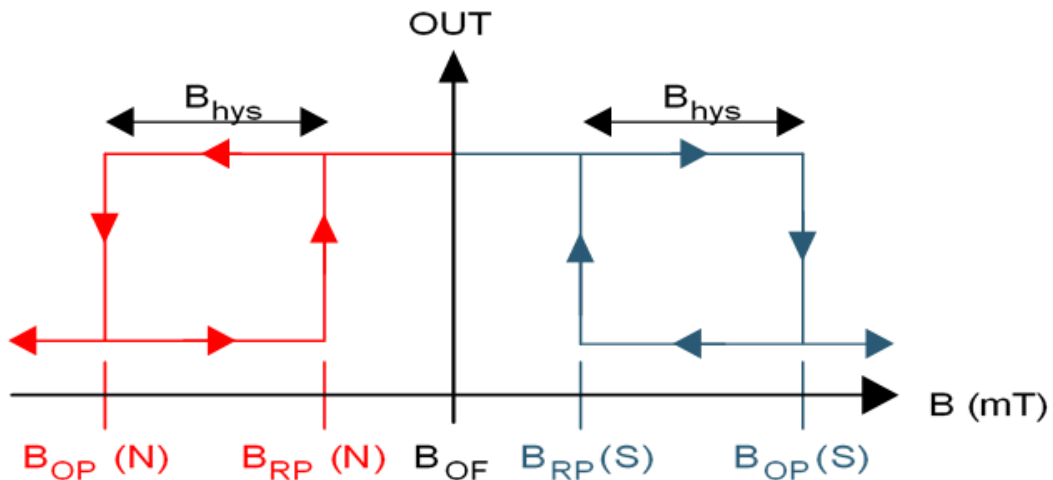

9.3 Overcurrent Protection (OCP)

An analog current-limit circuit limits the current through the FET. The driver current is clamped to IOCP. During this clamping, the rDS(on) of the output FET is increased from the nominal value.

10. Package Information:

**Package Designator
TO-92S**

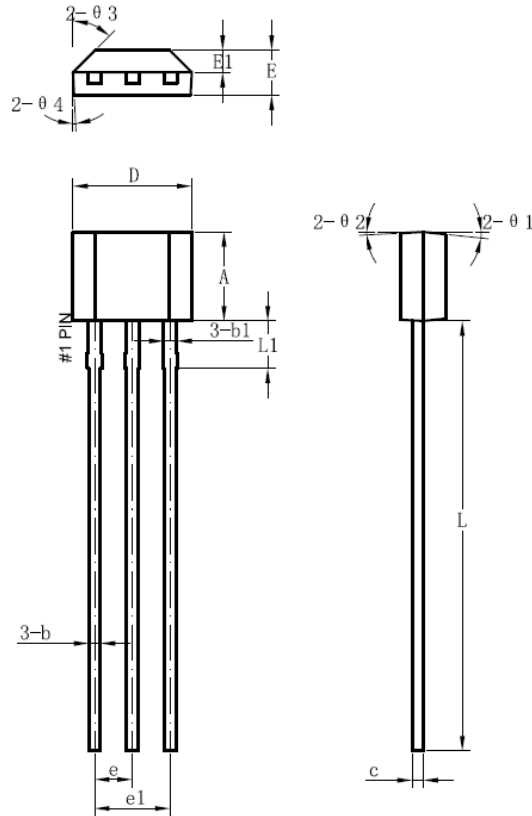

Symbol	Dimensions in Millimeters		
	Min.	Typ.	Max.
A	2.9	3	3.1
b	0.35	0.39	0.56
b1		0.44	
c	0.36	0.38	0.51
D	3.9	4	4.1
E	1.42	1.52	1.62
E1		0.75	
e		1.27	
e1		2.54	
L	13.5	14.5	15.5
L1		1.6	
$\theta 1$		6°	
$\theta 2$		3°	
$\theta 3$		45°	
$\theta 4$		3°	

PACKAGE DESIGNATOR
SOT-23-3L

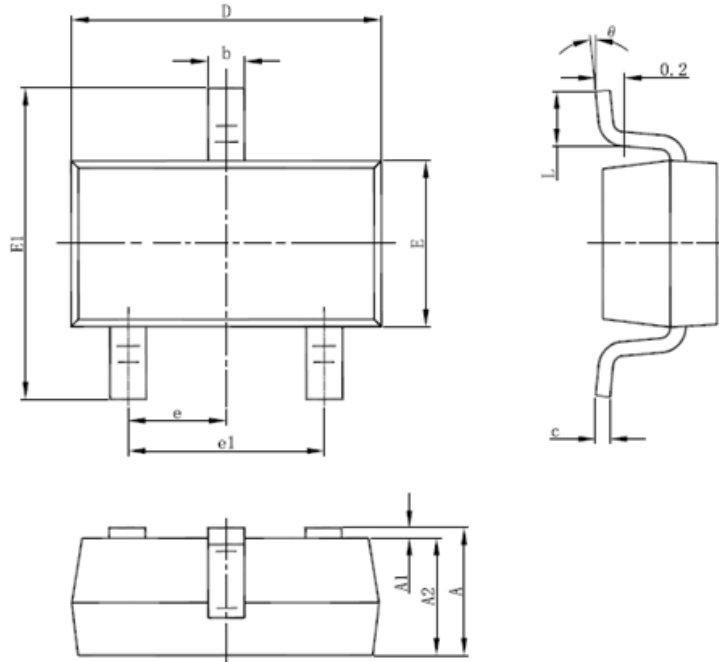

Symbol	Dimensions In Millimeters		Dimensions In Inches	
	Min	Max	Min	Max
A	1.050	1.250	0.041	0.049
A1	0.000	0.100	0.000	0.004
A2	1.050	1.150	0.041	0.045
b	0.300	0.500	0.012	0.020
c	0.100	0.200	0.004	0.008
D	2.820	3.020	0.111	0.119
E	1.500	1.700	0.059	0.067
E1	2.650	2.950	0.104	0.116
e	0.950(BSC)		0.037(BSC)	
e1	1.800	2.000	0.071	0.079
L	0.300	0.600	0.012	0.024
θ	0°	8°	0°	8°



Cosemitech
Automotive Product Group

CH913/CH913L
 This is advanced information on a new product now in development or undergoing evaluation. Details are subject to change without notice and Cosemitech assumes no obligation for future manufacture of this product. Contact Cosemitech for the latest status.

Preliminary Datasheet 1.8

TAPE AND REEL INFORMATION

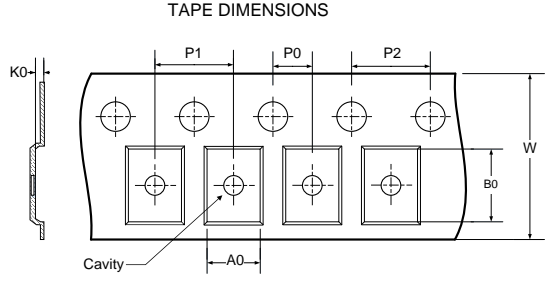
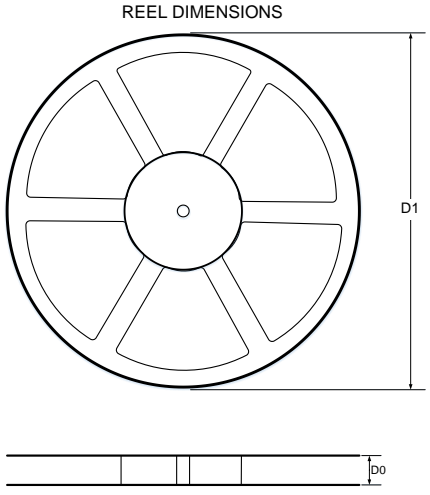

- A0: Dimension designed to accommodate the component width
- B0: Dimension designed to accommodate the component length
- K0: Dimension designed to accommodate the component thickness
- W: Overall width of the carrier tape
- P0: Pitch between successive cavity centers and sprocket hole
- P1: Pitch between successive cavity centers
- P2: Pitch between sprocket hole
- D1: Reel Diameter
- D0: Reel Width

QUADRANT ASSIGNMENTS FOR PIN 1 ORIENTATION IN TAPE

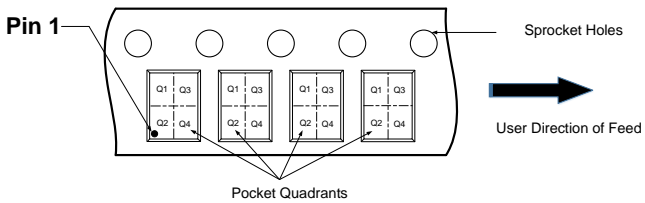

DIMENSIONS AND PIN1 ORIENTATION

D1 (mm)	D0 (mm)	A0 (mm)	B0 (mm)	K0 (mm)	P0 (mm)	P1 (mm)	P2 (mm)	W (mm)	Pin1 Quadrant
180	9	3.17	3.23	1.37	2	4	4	8	Q2

All dimensions are nominal

	Cosemitech	CH913/CH913L
	Automotive Product Group	<small>This is advanced information on a new product now in development or undergoing evaluation. Details are subject to change without notice and Cosemitech assumes no obligation for future manufacture of this product. Contact Cosemitech for the latest status.</small>

Preliminary Datasheet 1.8

Information furnished is believed to be accurate and reliable. However, Cosemitech assumes no responsibility for the consequences of use of such information nor for any infringement of patents or other rights of third parties which may result from its use. No license is granted by implication or otherwise under any patent or patent rights of Cosemitech. Specification mentioned in this publication are subject to change without notice. This publication supersedes and replaces all information previously supplied. Cosemitech products are not authorized for use as critical components in life support devices or systems without express written approval of Cosemitech.

The Cosemitech logo is a registered trademark of Cosemitech

单击下面可查看定价，库存，交付和生命周期等信息

[>>cosemitech\(意瑞半导体\)](#)