

	Cosemitech	CHA92X/CHI92X
	Automotive Product Group	<small>This is advanced information on a new product now in development or undergoing evaluation. Details are subject to change without notice and Cosemitech assumes no obligation for future manufacture of this product. Contact Cosemitech for the latest status.</small>

Preliminary Datasheet 1.4

FEATURES and FUNCTIONAL DIAGRAM	PACKAGE
--	----------------

- AEC-Q100 automotive qualified (CHA92X)
- Digital Unipolar-Switch Hall Sensor
- Superior Temperature Stability
- Multiple Sensitivity Options (BOP / BRP):
+30 / +15 Gauss; +70 / +30 Gauss; +140 / 60 Gauss; +150 / +100 Gauss; +250 / +200 Gauss
- On board voltage regulator for 2.5V to 22V range
- Open Drain Output (25-mA Sink)
- Resistant to physical stress
- Output short-circuit protection
- Operation from unregulated supply
- Reverse-battery and freewheeling protection
- Solid-state reliability
- Wide Operating temperature range: -40 to 150 °C
- Small package sizes TO-92S, SOT23 and SOT-89
- RoHS-compliant material meets directive 2011/65/EU

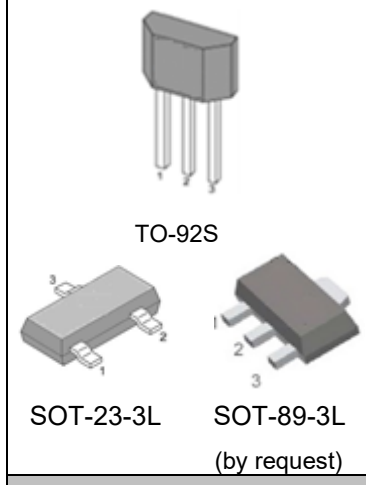
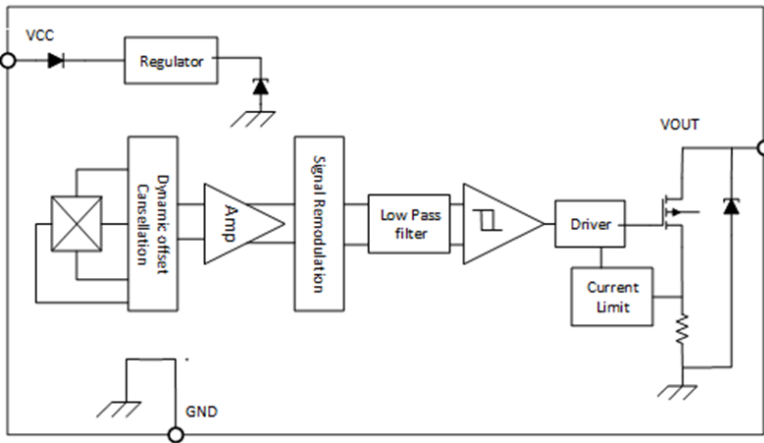

APPLICATIONS

- Docking Detection
- Door Open and Close Detection
- Proximity Sensing
- Valve Positioning
- Pulse Counting
- Flow rate sensing
- Robotic control (cylinder position monitoring)
- Float-based fluid level sensing
- Speed and RPM sensing in fitness equipment

DESCRIPTION

The CHA92X/CHI92X Hall-effect sensor is extremely temperature-stable and stress-resistant sensor ICs, especially suited for operation over extended temperature ranges from -40°C to 150°C. Superior high temperature performance is possible through dynamic offset cancellation, which reduces the residual offset voltage normally caused by device over-molding, temperature dependencies, and thermal stress.

The device includes a voltage regulator, Hall-voltage generator, small-signal amplifier, chopper stabilization, Schmitt trigger, and a short circuit protected open-drain output to sink up to 25 mA.

An on-board regulator permits operation with supply voltages of 2.5 to 22 V. The advantage of operating down to 2.5V is that the device can be used in 2.5V applications or with additional external resistance in series with the supply pin for greater protection against high-voltage transient events.

The CHA92X/CHI92X series is digital unipolar Hall switch. When the applied magnetic flux density exceeds the BOP threshold, the chip open-drain output goes low. The output stays low until the field decreases to less than BRP, and then the output goes to high impedance.

The CHA92X/CHI92X also integrated internal clamps against supply/output transients; output short circuits protection; reverse battery conditions.

Three package styles provide a magnetically optimized package for most applications, SOT-23, TO-92S and SOT-89. Each package type is lead (Pb) free (suffix, -T), with a 100% matte-tin-plated lead-frame.

	Cosemitech	CHA92X/CHI92X
	Automotive Product Group	<small>. This is advanced information on a new product now in development or undergoing evaluation. Details are subject to change without notice and Cosemitech assumes no obligation for future manufacture of this product. Contact Cosemitech for the latest status.</small>

Preliminary Datasheet 1.4

Table of Contents

1. Product Family Members		3
2. Pin Definitions and Descriptions		3
3. Absolute Maximum Ratings		4
4. ESD Protections		4
5. Function Description		5
6. Definition of Switching Function.....		5
7. Temperature Characterization		5
8. Parameters Specification		6
9. Application information.....		8
10. Test Condition		10
11. Package Information		11

	Cosemittech	CHA92X/CHI92X
	Automotive Product Group	<small>This is advanced information on a new product now in development or undergoing evaluation. Details are subject to change without notice and Cosemittech assumes no obligation for future manufacture of this product. Contact Cosemittech for the latest status.</small>

Preliminary Datasheet 1.4

1. Product Family Members

Part Number	Marking ID	Description
CHA921SR	C921	Unipolar-Switch, Hall-effect digital sensor IC, SOT-23-3L package, tape and reel packing (3000 units per reel)
CHA921TB	C921	Unipolar-Switch, Hall-effect digital sensor IC, flat, TO-92S package, bulk packing (1000 units per bag)
CHA921ER	C921	Unipolar-Switch, Hall-effect digital sensor IC, SOT-89-3L package, tape and reel packing (1000 units per reel)
CHA922SR	C922	Unipolar-Switch, Hall-effect digital sensor IC, SOT-23-3L package, tape and reel packing (3000 units per reel)
CHA922TB	C922	Unipolar-Switch, Hall-effect digital sensor IC, flat, TO-92S package, bulk packing (1000 units per bag)
CHA922ER	C922	Unipolar-Switch, Hall-effect digital sensor IC, SOT-89-3L package, tape and reel packing (1000 units per reel)
CHA923SR	C923	Unipolar-Switch, Hall-effect digital sensor IC, SOT-23-3L package, tape and reel packing (3000 units per reel)
CHA923TB	C923	Unipolar-Switch, Hall-effect digital sensor IC, flat, TO-92S package, bulk packing (1000 units per bag)
CHA923ER	C923	Unipolar-Switch, Hall-effect digital sensor IC, SOT-89-3L package, tape and reel packing (1000 units per reel)
CHA924SR	C924	Unipolar-Switch, Hall-effect digital sensor IC, SOT-23-3L package, tape and reel packing (3000 units per reel)
CHA924TB	C924	Unipolar-Switch, Hall-effect digital sensor IC, flat, TO-92S package, bulk packing (1000 units per bag)
CHA924ER	C924	Unipolar-Switch, Hall-effect digital sensor IC, SOT-89-3L package, tape and reel packing (1000 units per reel)
CHA925SR	C925	Unipolar-Switch, Hall-effect digital sensor IC, SOT-23-3L package, tape and reel packing (3000 units per reel)
CHA925TB	C925	Unipolar-Switch, Hall-effect digital sensor IC, flat, TO-92S package, bulk packing (1000 units per bag)
CHA925ER	C925	Unipolar-Switch, Hall-effect digital sensor IC, SOT-89-3L package, tape and reel packing (1000 units per reel)
CHI921SR	I921	Unipolar-Switch, Hall-effect digital sensor IC, SOT-23-3L package, tape and reel packing (3000 units per reel)
CHI921TB	I921	Unipolar-Switch, Hall-effect digital sensor IC, flat, TO-92S package, bulk packing (1000 units per bag)
CHI921ER	I921	Unipolar-Switch, Hall-effect digital sensor IC, SOT-89-3L package, tape and reel packing (1000 units per reel)
CHI922SR	I922	Unipolar-Switch, Hall-effect digital sensor IC, SOT-23-3L package, tape and reel packing (3000 units per reel)
CHI922TB	I922	Unipolar-Switch, Hall-effect digital sensor IC, flat, TO-92S package, bulk packing (1000 units per bag)
CHI922ER	I922	Unipolar-Switch, Hall-effect digital sensor IC, SOT-89-3L package, tape and reel packing (1000 units per reel)
CHI923SR	I923	Unipolar-Switch, Hall-effect digital sensor IC, SOT-23-3L package, tape and reel packing (3000 units per reel)
CHI923TB	I923	Unipolar-Switch, Hall-effect digital sensor IC, flat, TO-92S package, bulk packing (1000 units per bag)
CHI923ER	I923	Unipolar-Switch, Hall-effect digital sensor IC, SOT-89-3L package, tape and reel packing (1000 units per reel)
CHI924SR	I924	Unipolar-Switch, Hall-effect digital sensor IC, SOT-23-3L package, tape and reel packing (3000 units per reel)

	Cosemittech	CHA92X/CHI92X
	Automotive Product Group	<small>. This is advanced information on a new product now in development or undergoing evaluation. Details are subject to change without notice and Cosemittech assumes no obligation for future manufacture of this product. Contact Cosemittech for the latest status.</small>

Preliminary Datasheet 1.4

CHI924TB	I924	Unipolar-Switch, Hall-effect digital sensor IC, flat, TO-92S package, bulk packing (1000 units per bag)
CHI924ER	I924	Unipolar-Switch, Hall-effect digital sensor IC, SOT-89-3L package, tape and reel packing (1000 units per reel)
CHI925SR	I925	Unipolar-Switch, Hall-effect digital sensor IC, SOT-23-3L package, tape and reel packing (3000 units per reel)
CHI925TB	I925	Unipolar-Switch, Hall-effect digital sensor IC, flat, TO-92S package, bulk packing (1000 units per bag)
CHI925ER	I925	Unipolar-Switch, Hall-effect digital sensor IC, SOT-89-3L package, tape and reel packing (1000 units per reel)

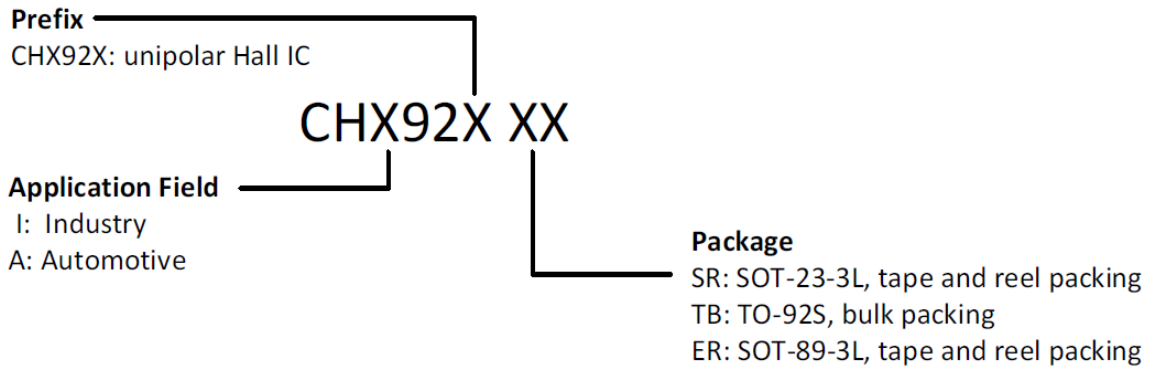

2. Pin Definitions and Descriptions

SOT-23-3L (S)	TO-92S (T)	SOT-89-3L (E)	Name	Type	Function
1	1	1	VDD	Supply	Supply Voltage pin
2	3	3	OUT	Output	Open Collector Output pin
3	2	2	GND	Ground	Ground pin

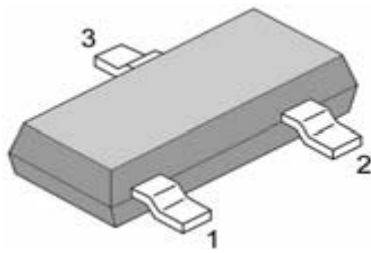
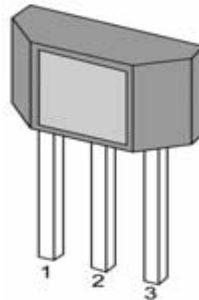
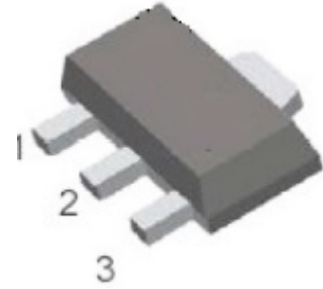
SOT-23-3L

TO-92S

SOT-89-3L

3. Absolute Maximum Ratings

Parameter	Symbol	Min	Max	Units
Supply Voltage	V_{DD}	-	24	V
VDD Reverse Voltage VDD	V_{RDD}	-22		V
Supply Current	I_{DD}	-	20	mA
Output Voltage	V_{OUT}	-0.3	24	V
Output Current	I_{OUT}	-	25	mA
Operating Ambient Temperature	T_A	-40	150	°C
Storage Temperature	T_S	-50	150	°C
Junction temperature	T_J	-50	165	°C
Magnetic Flux	B	No Limit		Gauss

Note: Exceeding the absolute maximum ratings may cause permanent damage. Exposure to absolute-maximum-rated conditions for extended periods may affect device reliability.

4. ESD Protections

Parameter	Value	Unit
All pins ¹⁾	+/-8000	V
All pins ²⁾	+/-200	V
All pins ³⁾	+/-750	V

1) HBM (Human Body Mode) according to AEC-Q100-002

2) MM (Machine Mode) according to AEC-Q100-003

3) CDM (charged device mode) according to AEC-Q100-011

5. Function Description

The CHA92X/CHI92X exhibits digital unipolar switching characteristics. Therefore, it requires only south poles or north poles (depend on the package type) to operate properly.

When the applied magnetic flux density exceeds the BOP threshold, the chip open-drain output goes low. The output stays low until the field decreases to less than BRP, and then the output goes to high impedance.

A magnetic hysteresis BHYST keeps BOP and BRP separated by a minimal value. This hysteresis prevents output oscillation near the switching point.

6. Magnetic Activation

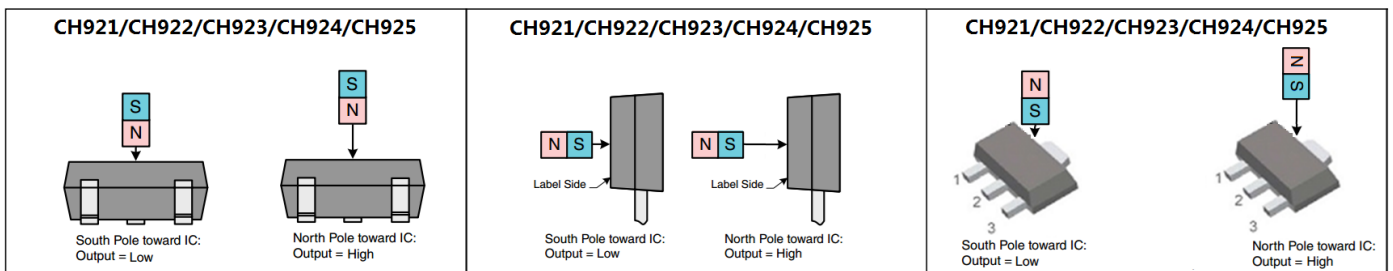

7. Temperature Characteristics

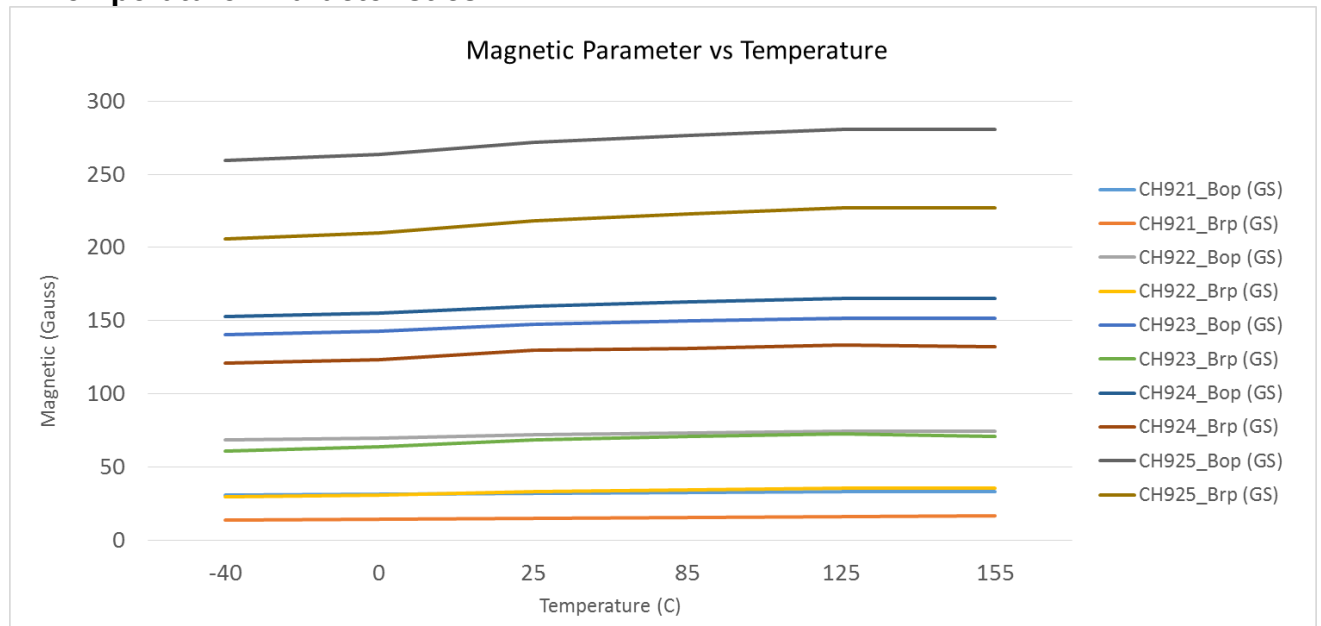

	Cosemitech	CHA92X/CHI92X
	Automotive Product Group	<small>This is advanced information on a new product now in development or undergoing evaluation. Details are subject to change without notice and Cosemitech assumes no obligation for future manufacture of this product. Contact Cosemitech for the latest status.</small>

Preliminary Datasheet 1.4

8. Parameters Specification (VCC=3.3V supply, TA= -40 °C to 150 °C except where otherwise specified.)

Symbol	Parameter	Test Condition	Min	Typ.	Max	Units
V _{DD}	Supply voltage	-40 °C to 150 °C	2.5	-	22	V
I _{DD}	Supply Current	V _{DD} = 3.3V	-	1.6	3	mA
V _{ZSUPPLY}	Supply Zener Clamp Voltage	I _{CC} = 7 mA; TA = 25°C	24			V
V _{ZOUT}	Output Zener Clamp Voltage	I _{OUT} = 3mA	24			V
V _{RCC}	Reverse Battery Zener				-22	V
I _{RCC}	Reverse Battery Current	V _{CC} = -22 V	-5			mA
F _C	Chopping Frequency			500		KHz
t _{PO}	Power-On Time	TA = 25°C; C _{LOAD} = 10 pF	-	-	30	µs
V _{DSon}	Output saturation voltage	at 20mA, Gauss >BOP	-	-	0.4	V
I _{OFF}	Output Leakage Current	V _{OUT} = 24 V; Switch state = Off	-	-	10	µA
I _{OUT(lim)}	Output Current Limit	Short-Circuit Protection	30	-	90	mA
T _R	Output rise time	R _{LOAD} = 820 Ω, C _{LOAD} = 10 pF;	-	0.2	2	µs
T _F	Output fall time	R _{LOAD} = 820Ω, C _{LOAD} = 10 pF;	-	0.1	2	µs
T _d	Output delay Time	B=Brp-100G to Bop+100G in 1us		13	25	µs
R _{TH}	Thermal resistance: SOT-23-3L TO-92S SOT-89-3L	-	-	303 203 230	-	°C /W °C/W °C/W
F _{SW(2)}	Maximum Switching Frequency		20	30		KHz
T	Operating temperature	-	-40	-	150	°C
T _S	Storage temperature:	-	-40	-	150	°C
CHA921/CHI921						
B _{OP}	Magnetic operating point	T _A =-40°C to 150°C	20	35	50	Gauss
B _{RP}	Magnetic release point	T _A =-40°C to 150°C	10	20	40	Gauss
B _{HYST}	Magnetic hysteresis window BOP-BRP	T _A =-40°C to 150°C	10	15	30	Gauss
B ₀	Magnetic offset; B ₀ = (BOP + BRP) / 2	T _A =-40°C to 150°C		27.5		Gauss
CHA922/CHI922						
B _{OP}	Magnetic operating point	T _A =-40°C to 150°C	40	60	80	Gauss
B _{RP}	Magnetic release point	T _A =-40°C to 150°C	20	30	50	Gauss
B _{HYST}	Magnetic hysteresis window BOP-BRP	T _A =-40°C to 150°C	15	30	45	Gauss
B ₀	Magnetic offset; B ₀ = (BOP + BRP) / 2	T _A =-40°C to 150°C		45		Gauss
CHA923/CHI923						
B _{OP}	Magnetic operating point	T _A =-40°C to 150°C	110	140	170	Gauss

	Cosemitech	CHA92X/CHI92X
	Automotive Product Group	<small>. This is advanced information on a new product now in development or undergoing evaluation. Details are subject to change without notice and Cosemitech assumes no obligation for future manufacture of this product. Contact Cosemitech for the latest status.</small>

Preliminary Datasheet 1.4

B_{RP}	Magnetic release point	$T_A = -40^{\circ}\text{C}$ to 150°C	40	60	80	Gauss
B_{HYST}	Magnetic hysteresis window $ BOP - BRP $	$T_A = -40^{\circ}\text{C}$ to 150°C	50	80	110	Gauss
B_o	Magnetic offset; $B_o = (BOP + BRP) / 2$	$T_A = -40^{\circ}\text{C}$ to 150°C		100		Gauss
CHA924/CHI924						
B_{OP}	Magnetic operating point	$T_A = -40^{\circ}\text{C}$ to 150°C	120	145	170	Gauss
B_{RP}	Magnetic release point	$T_A = -40^{\circ}\text{C}$ to 150°C	80	105	130	Gauss
B_{HYST}	Magnetic hysteresis window $ BOP - BRP $	$T_A = -40^{\circ}\text{C}$ to 150°C	25	40	60	Gauss
B_o	Magnetic offset; $B_o = (BOP + BRP) / 2$	$T_A = -40^{\circ}\text{C}$ to 150°C		125		Gauss
CHA925/CHI925						
B_{OP}	Magnetic operating point	$T_A = -40^{\circ}\text{C}$ to 150°C	210	250	290	Gauss
B_{RP}	Magnetic release point	$T_A = -40^{\circ}\text{C}$ to 150°C	160	200	240	Gauss
B_{HYST}	Magnetic hysteresis window $ BOP - BRP $	$T_A = -40^{\circ}\text{C}$ to 150°C	25	50	75	Gauss
B_o	Magnetic offset; $B_o = (BOP + BRP) / 2$	$T_A = -40^{\circ}\text{C}$ to 150°C		225		Gauss

(1) 1 mT = 10 Gauss

(2) Bandwidth describes the fastest changing magnetic field that can be detected and translated to the output.

NOTICE

The magnetic field strength (Gauss) required to cause the switch to change state (operate and release) will be as specified in the magnetic characteristics. To test the switch against the specified magnetic characteristics, the switch must be placed in a uniform magnetic field.

9. Application Information

9.1 Typical Application

It is recommended that an external capacitor C1 is connected to the supply. This can reduce the noise injected into the device. Normal 0.1uF is suggested.

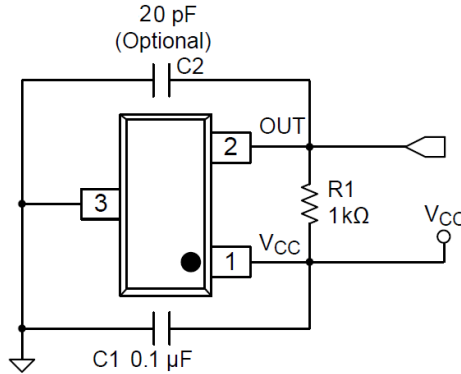

Typical Application Circuit

9.2 Device Output

If the device is powered on with a magnetic field strength between BRP and BOP, then the device output is indeterminate and can either be Hi-Z or Low. If the field strength is greater than BOP, then the output is pulled low. If the field strength is less than BRP, then the output is released.

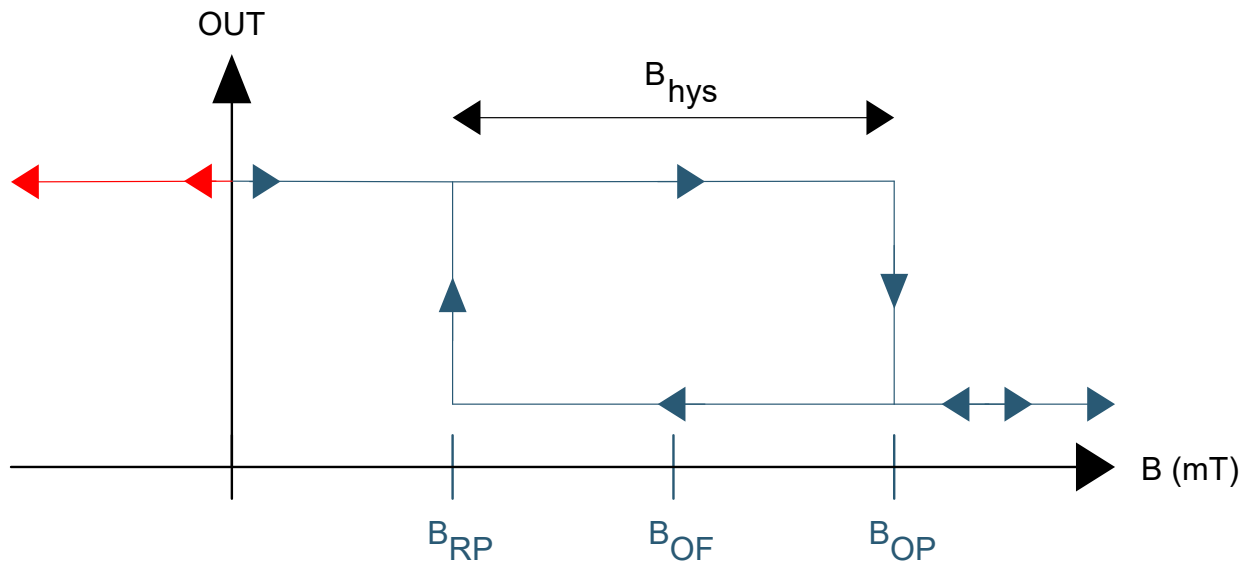

9.3 Output Stage

The CHA92X/CHI92X output stage uses an open-drain NMOS, and it is rated to sink up to 30 mA of current. For proper operation, calculate the value of the pullup resistor R1 using Equation 1.

$$\frac{V_{ref\ max}}{30\ mA} \leq R1 \leq \frac{V_{ref\ min}}{100\ \mu A} \quad (1)$$

The size of R1 is a tradeoff between the OUT rise time and the current when OUT is pulled low. A lower current is generally better, however faster transitions and bandwidth require a smaller resistor for faster switching. In addition, ensure that the value of R1 > 500 Ω to ensure the output driver can pull the OUT pin close to GND.

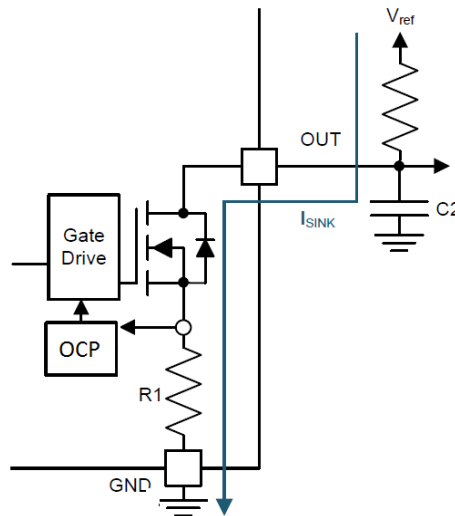

Select a value for C2 based on the system bandwidth specifications as shown in [Equation 2](#).

$$2 \times f_{BW} \text{ (Hz)} < \frac{1}{2\pi \times R1 \times C2} \quad (2)$$

Most applications do not require this C2 filtering capacitor.

9.4 Protection Circuits

The CHA92X/CHI92X device is fully protected against overcurrent and reverse-supply conditions.

9.5 Overcurrent Protection (OCP)

An analog current-limit circuit limits the current through the FET. The driver current is clamped to IOCP. During this clamping, the rDS(on) of the output FET is increased from the nominal value.

9.6 Reverse Supply Protection

The CHA92X/CHI92X device is protected in the event that the VCC pin and the GND pin are reversed (up to -22 V).

9.7 Alternative Two-Wire Application

For systems that require minimal wire count, the device output can be connected to VCC through a resistor, and the total supplied current can be sensed near the controller.

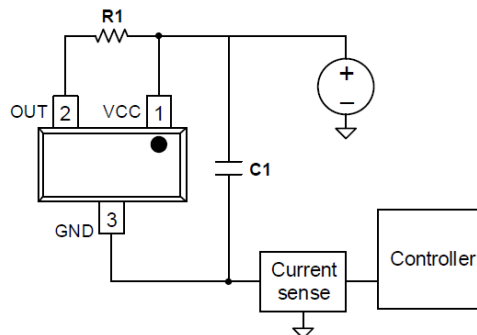

2-Wire Application

Current can be sensed using a shunt resistor or other circuitry.

10. Test Conditions

Note: DUT=Device Under Test

Supply Current

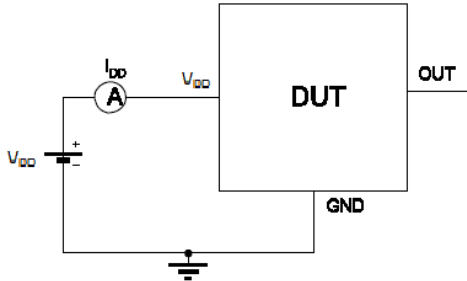

Note 1 - The supply current I_{DD} represents the static supply current. OUT is left open during measurement

Note 2 - The device is put under magnetic field with $B < B_{RP}$

Output Saturation Voltage

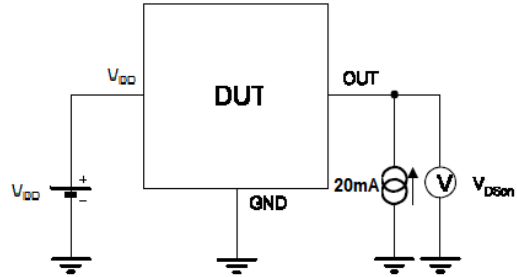

Note 1 - The output saturation voltage V_{DSon} is measured at $V_{DD}=3.3V$ and $V_{DD}=20V$

Note 2 - The device is put under magnetic field with $B > B_{OP}$

Output Leakage Current

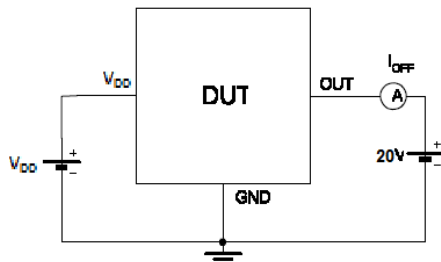

Note 1 - The device is put under magnetic field with $B < B_{RP}$

Magenetic Thresholds

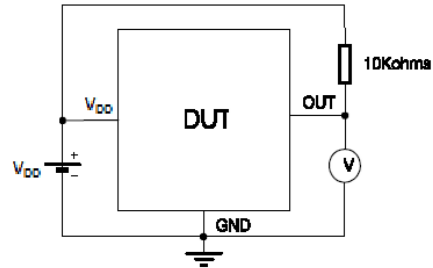

Note 1 - B_{OP} is determined by putting the device under magnetic field swept from B_{RPmin} up to B_{OPmax} until the output is switched on.

Note 2 - B_{RP} is determined by putting the device under magnetic field swept from B_{OPmax} down to B_{RPmin} until the output is switched off.



Cosemitech

CHA92X/CHI92X

Automotive Product Group

. This is advanced information on a new product now in development or undergoing evaluation. Details are subject to change without notice and Cosemitech assumes no obligation for future manufacture of this product. Contact Cosemitech for the latest status.

Preliminary Datasheet 1.4

11. Package Information:

**PACKAGE DESIGNATOR
TO-92S**

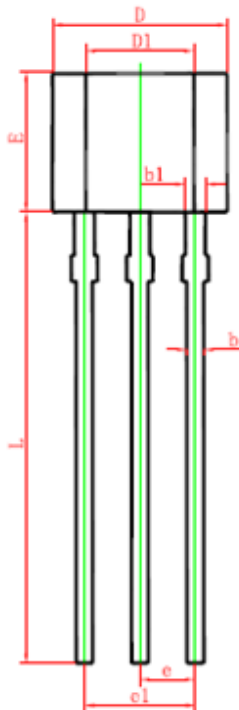
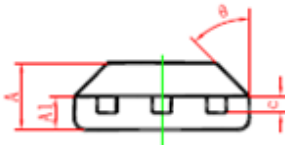

Symbol	Dimensions In Millimeters		Dimensions In Inches	
	Min.	Max.	Min.	Max.
A	1.420	1.620	0.056	0.064
A1	0.660	0.860	0.026	0.034
b	0.350	0.480	0.014	0.019
b1	0.400	0.550	0.016	0.022
c	0.360	0.510	0.014	0.020
D	3.900	4.100	0.154	0.161
D1	2.280	2.680	0.090	0.106
E	3.050	3.250	0.120	0.128
e	1.270 TYP.		0.050 TYP.	
e1	2.440	2.640	0.096	0.104
L	15.100	15.500	0.594	0.610
θ	45° TYP.		45° TYP.	

PACKAGE DESIGNATOR
SOT-23-3L

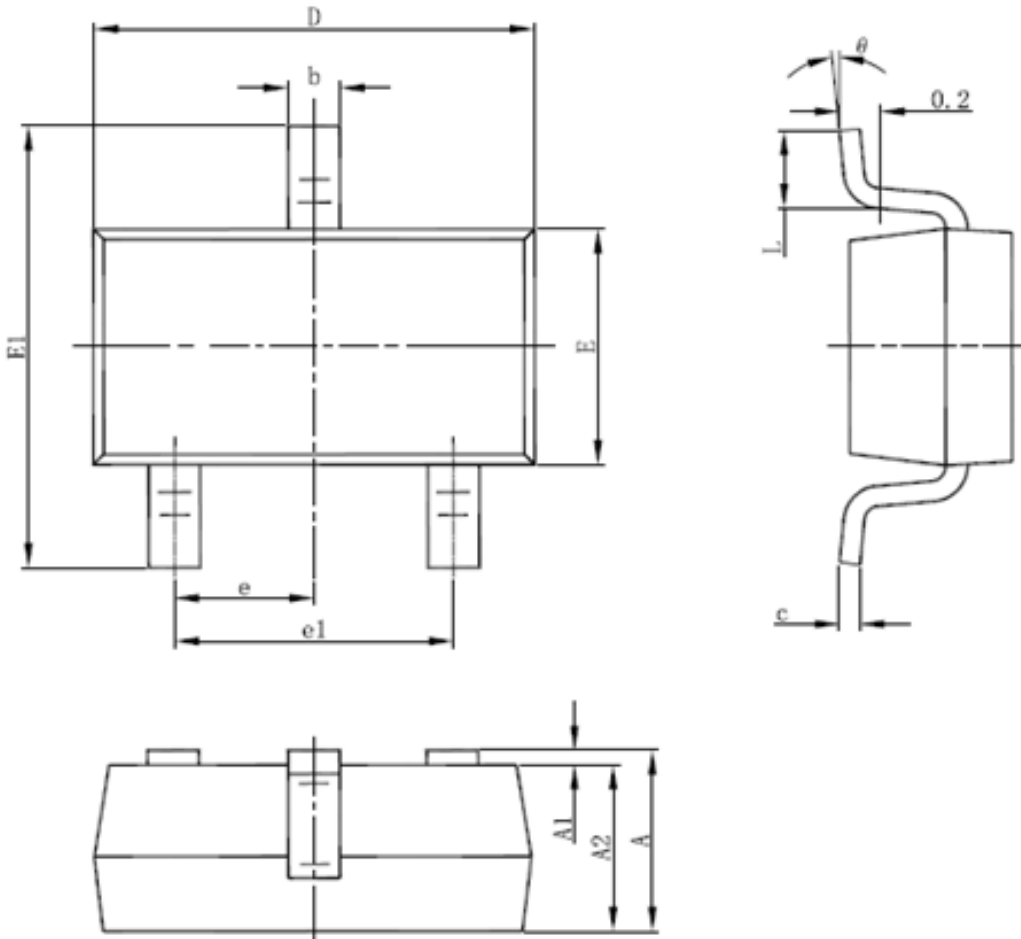

Symbol	Dimensions In Millimeters		Dimensions In Inches	
	Min	Max	Min	Max
A	1.050	1.250	0.041	0.049
A1	0.000	0.100	0.000	0.004
A2	1.050	1.150	0.041	0.045
b	0.300	0.500	0.012	0.020
c	0.100	0.200	0.004	0.008
D	2.820	3.020	0.111	0.119
E	1.500	1.700	0.059	0.067
E1	2.650	2.950	0.104	0.116
e	0.950(BSC)		0.037(BSC)	
e1	1.800	2.000	0.071	0.079
L	0.300	0.600	0.012	0.024
θ	0°	8°	0°	8°



Cosemitech

CHA92X/CHI92X

Automotive Product Group

. This is advanced information on a new product now in development or undergoing evaluation. Details are subject to change without notice and Cosemitech assumes no obligation for future manufacture of this product. Contact Cosemitech for the latest status.

Preliminary Datasheet 1.4

**PACKAGE DESIGNATOR
SOT-89-3L**

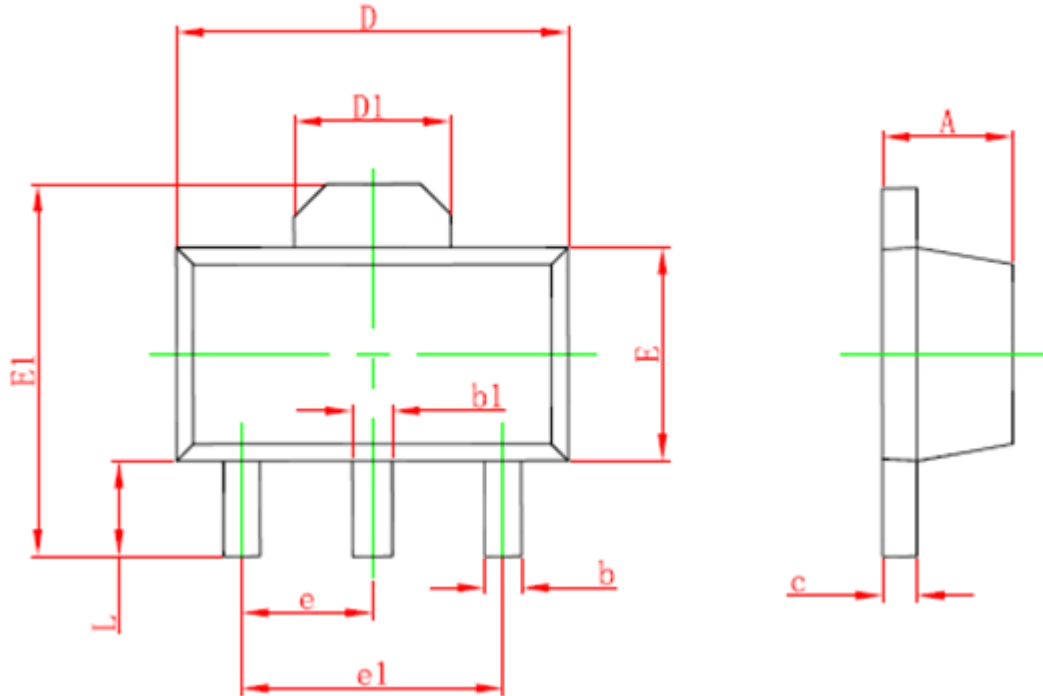

Symbol	Dimensions In Millimeters		Dimensions In Inches	
	Min.	Max.	Min.	Max.
A	1.400	1.600	0.055	0.063
b	0.320	0.520	0.013	0.020
b1	0.400	0.580	0.016	0.023
c	0.350	0.440	0.014	0.017
D	4.400	4.600	0.173	0.181
D1	1.550 REF.		0.061 REF.	
E	2.300	2.600	0.091	0.102
E1	3.940	4.250	0.155	0.167
e	1.500 TYP.		0.060 TYP.	
e1	3.000 TYP.		0.118 TYP.	
L	0.900	1.200	0.035	0.047

	Cosemitech	CHA92X/CHI92X
	Automotive Product Group	<small>This is advanced information on a new product now in development or undergoing evaluation. Details are subject to change without notice and Cosemitech assumes no obligation for future manufacture of this product. Contact Cosemitech for the latest status.</small>

Preliminary Datasheet 1.4

Information furnished is believed to be accurate and reliable. However, Cosemitech assumes no responsibility for the consequences of use of such information nor for any infringement of patents or other rights of third parties which may result from its use. No license is granted by implication or otherwise under any patent or patent rights of Cosemitech. Specification mentioned in this publication are subject to change without notice. This publication supersedes and replaces all information previously supplied. Cosemitech products are not authorized for use as critical components in life support devices or systems without express written approval of Cosemitech.

The Cosemitech logo is a registered trademark of Cosemitech

单击下面可查看定价，库存，交付和生命周期等信息

[>>cosemitech\(意瑞半导体\)](#)