

600V HIGH- AND LOW-SIDE GATE DRIVER

Features

- High side fully operational to +600V
- Floating channel designed for bootstrap operation
- Output source/sink current capability 2.5A
- Common-Mode dV/dt noise canceling circuit
- Gate drive supply range from 10V to 20V
- Under-voltage lockout for both channels
- 3.3V logic compatible
- Logic and power ground $\pm 5V$ offset
- CMOS Schmitt-triggered inputs with pull-down
- Cycle by cycle edge-triggered shutdown logic
- Outputs in phase with inputs
- Matched propagation delay for both channels

General Description

The COS2181/COS21814 are high voltage, high speed, power MOSFET and IGBT drivers with independent high-side and low-side referenced output channels. The output drivers feature a high pulse current buffer stage designed for minimum driver cross conduction. Propagation delays are matched to simplify use in high frequency applications. The floating channel can be used to drive an N-channel power MOSFET or IGBT in the high-side configuration which operates up to 600V. The Logic inputs of COS2181/COS21814 are compatible with standard CMOS or TTL output, down to 3.3V logic. COS2181 is available in Green SOP8 and DIP8 Packages. COS21814 is available in Green SOP14 and DIP14 Packages.

Applications

- Motor Drivers
- Full/Half Bridge Converters
- Two Switch forward Converter

Rev1.1
 Copyright © 2022 Cosine Nanoelectronics Inc. All rights reserved.
 The information provided here is believed to be accurate and reliable. Cosine Nanoelectronics assumes no liability for inaccuracies and omissions. Specifications described and contained here are subjected to change without notice on the purpose of improving the design and performance. All of this information described herein should not be implied or granted for any third party.

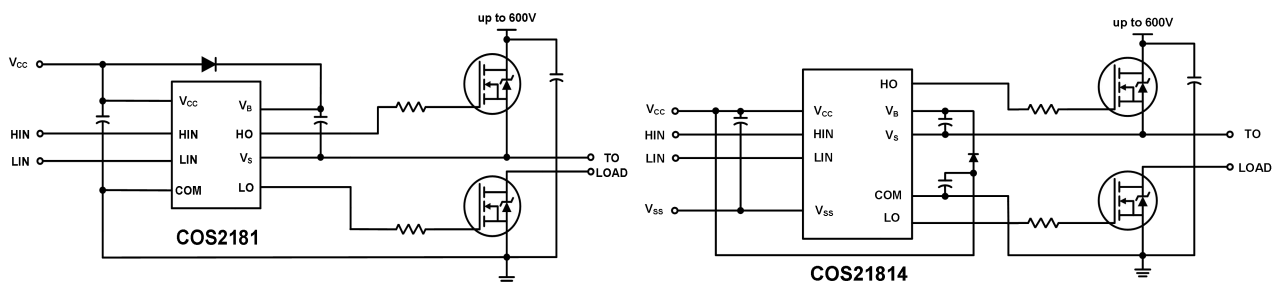

Typical Connection

1. Pin Configuration and Functions

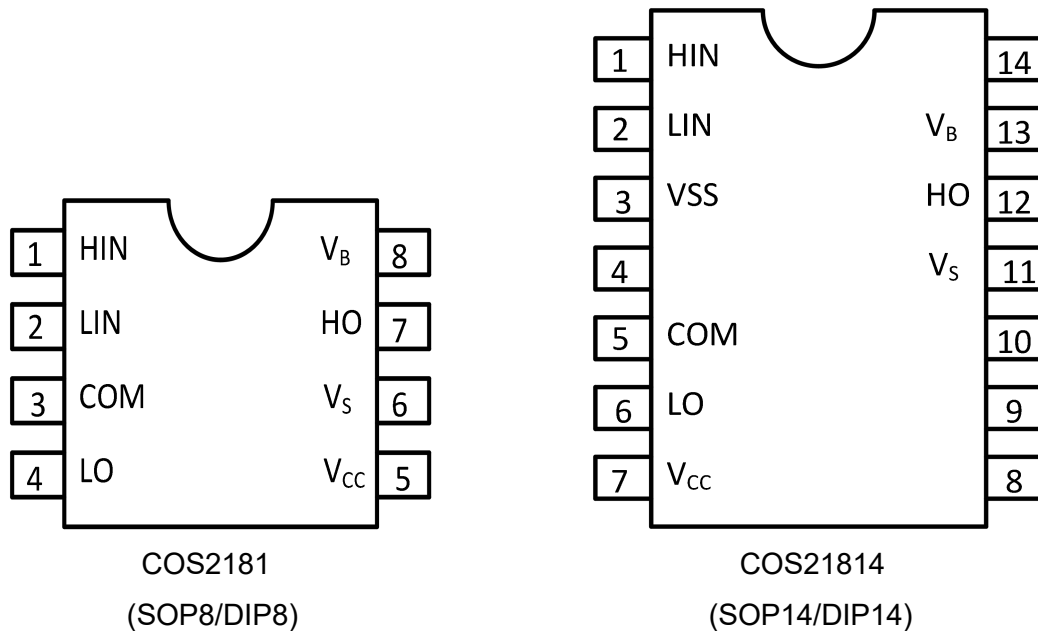

Figure 1. Pin Diagram

Pin Description

Name	Pin No. (COS2181)	Pin No. (COS21814)	Description
HIN	1	1	Logic input for high-side gate driver output (HO), in phase
LIN	2	2	Logic input for low-side gate driver output (LO), in phase
VSS	-	3	Logic ground (COS21814 only)
VB	8	13	High-side floating supply
HO	7	12	High-side gate drive output
VS	6	11	High-side floating supply return
VCC	5	7	Low-side supply
LO	4	6	Low-side gate drive output
COM	3	5	Low-side return

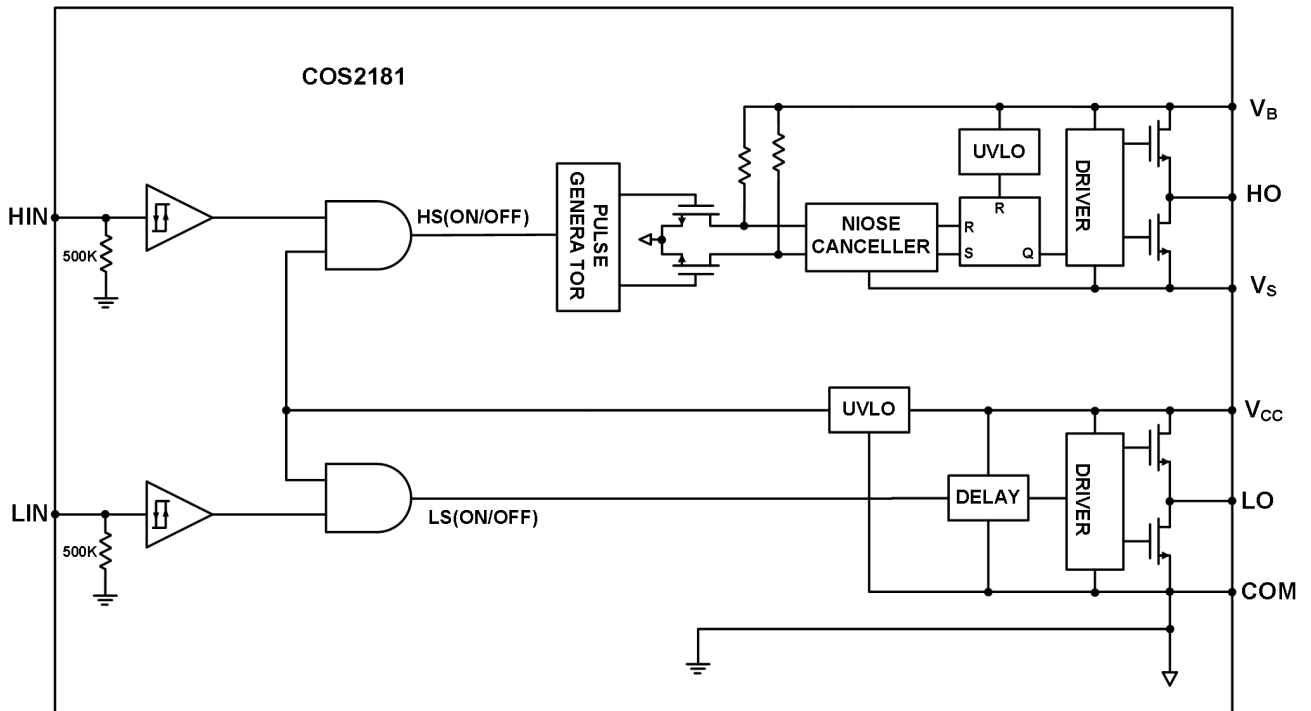

Figure 2. Functional Block Diagram of COS2181

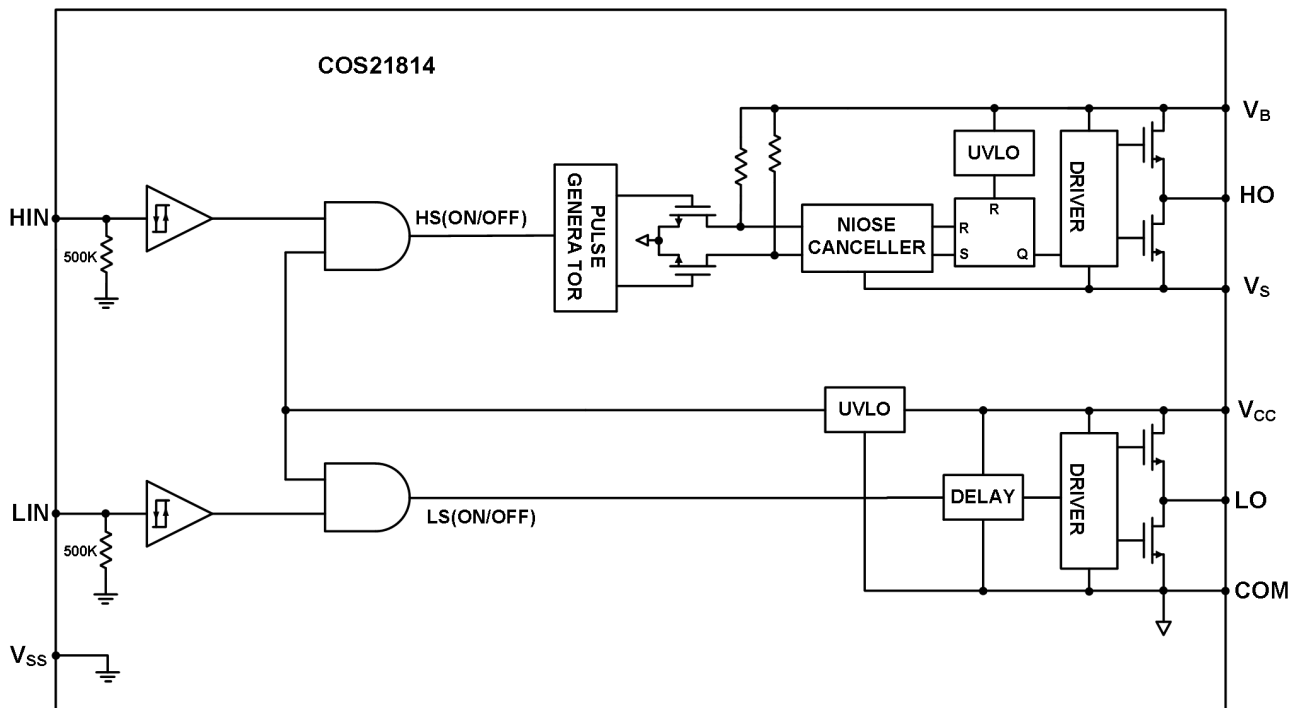

Figure 3. Functional Block Diagram of COS21814

2. Product Specification

2.1 Absolute Maximum Ratings ⁽¹⁾

Parameter	Symbol	Min	Max	Unit
High-side floating supply voltage	VB	-0.3	620	V
High-side floating supply offset voltage	VS	VB - 20	VB + 0.3	V
High-side floating output voltage	VHO	VS - 0.3	VB + 0.3	V
Low-side fixed supply voltage	VCC	-0.3	20	V
Low-side output voltage	VLO	-0.3	VCC + 0.3	V
Logic supply offset voltage (COS21814 only)	VSS	VCC-20	VSS + 0.3	V
Logic input voltage (HIN, LIN)	VIN	VSS-0.3	VCC + 0.3	V
Allowable offset supply voltage transient	dVs/dt	-	50	V/ns
Junction temperature	TJ	-	150	°C
Storage temperature	Ts	- 55	150	°C
Lead temperature (soldering, 10 seconds)	TL	-	300	°C

(1) Stresses exceeding the absolute maximum ratings may damage the device. The device may not function or be operable above the recommended operating conditions and stressing the parts to these levels is not recommended. In addition, extended exposure to stresses above the recommended operating conditions may affect device reliability. The absolute maximum ratings are stress ratings only.

2.2 Thermal Data

Parameter	Rating	Unit
Package Thermal Resistance	155 (SOP8) 82 (SOP14) 125 (DIP8) 75 (DIP14)	°C/W

2.3 Recommended Operating Conditions

Parameter	Symbol	Min	Max	Unit
High-side floating supply absolute voltage	VB	VS+10	VS+20	V
High-side floating supply offset voltage	VS	-5	600	
High-side floating output voltage	VHO	VS	VB	
Low-side and logic fixed supply voltage	VCC	10	20	
Low-side output voltage	VLO	0	VCC	
Logic input voltage (HIN, LIN)	VIN	VSS	VCC	
Logic supply offset voltage	VSS	-5	5	
Operation temperature	TA	-40	125	°C

2.4 Electrical Characteristics

VBIAS (VCC, VBS) = 15 V, $T_A = 25\text{ }^\circ\text{C}$, $C_L = 1000\text{pF}$ and VSS = COM, unless otherwise specified.

Parameter	Symbol	Conditions	Min.	Typ.	Max.	Unit
INPUT						
Input signal high threshold	V_{IH}		2.5	-		V
Input signal low threshold	V_{IL}			-	0.8	V
Logic "1" input bias current	I_{IN+}	$V_{IN} = 5\text{V}$		10	20	μA
Logic "0" input bias current	I_{IN-}	$V_{IN} = 0\text{V}$		-	2.0	μA
OUTPUT						
High level output voltage, $V_{BIAS} - V_O$	V_{OH}	$I_O = 20\text{mA}$		-	1.4	V
Low level output voltage	V_{OL}			-	0.15	V
Output high short circuit pulsed current	I_{O+}	$V_O = 0\text{V}$, $V_{IN} = V_{CC}$ $PW \leq 10\text{ }\mu\text{s}$	2.0	2.5	-	A
Output low short circuit pulsed current	I_{O-}	$V_O = 15\text{V}$, $V_{IN} = 0$ $PW \leq 10\text{ }\mu\text{s}$	2.0	2.5	-	A
POWER SUPPLY						
Quiescent VBS supply current	I_{QBS}	$V_{IN} = 0\text{V}$ or V_{CC}	-	50	100	μA
Quiescent VCC supply current	I_{QCC}		-	50	700	μA
Offset supply leakage current	I_{LK}	$V_B = V_S = 600\text{V}$	-	-	150	μA
VCC and VBS supply under voltage positive going threshold	V_{BSUV+} V_{CCUV+}		7.5	8.6	9.7	V
VCC and VBS supply under voltage negative going threshold	V_{BSUV-} V_{CCUV-}		7.0	8.1	9.2	V
VCC and VBS supply under-voltage lockout hysteresis	V_{BSHY} V_{CCHY}		-	0.5	-	V
SWITCHING CHARACTERISTICS						
Turn-on Rise Time	t_R	$C_L = 1000\text{pF}$, See Figure 4, 5, 6	-	18	30	ns
Turn-off Fall Time	t_F		-	13	20	ns
Turn-On Propagation Delay	t_{on}		-	128	150	ns
Turn-Off Propagation Delay	t_{off}		-	124	150	ns
Delay matching, turn-on/off	MT		-	10	-	ns

3. Application Information

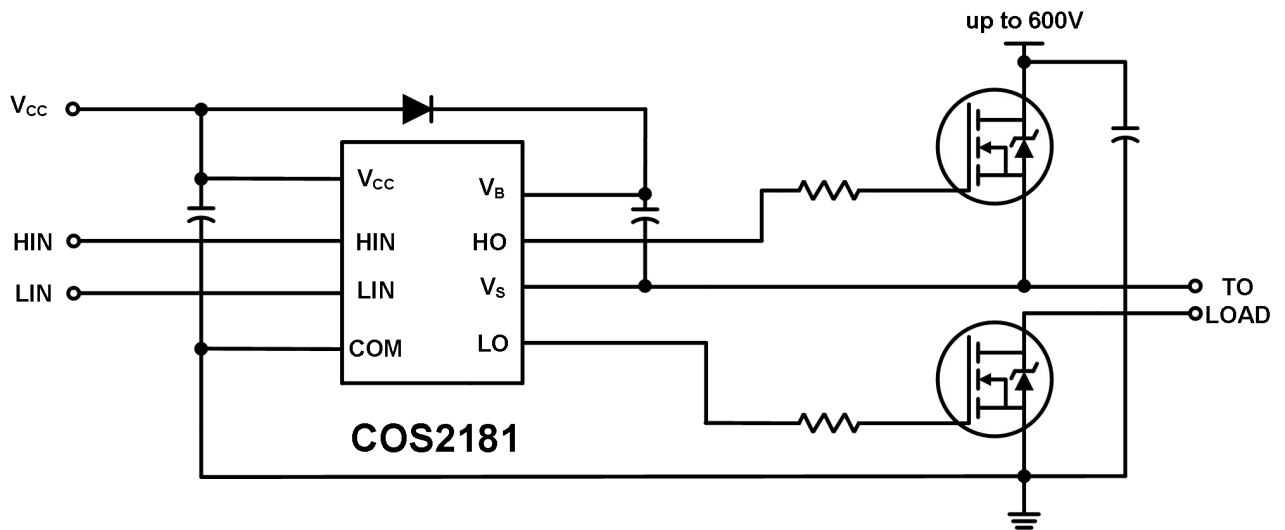

Figure 4. COS2181 Typical Connection

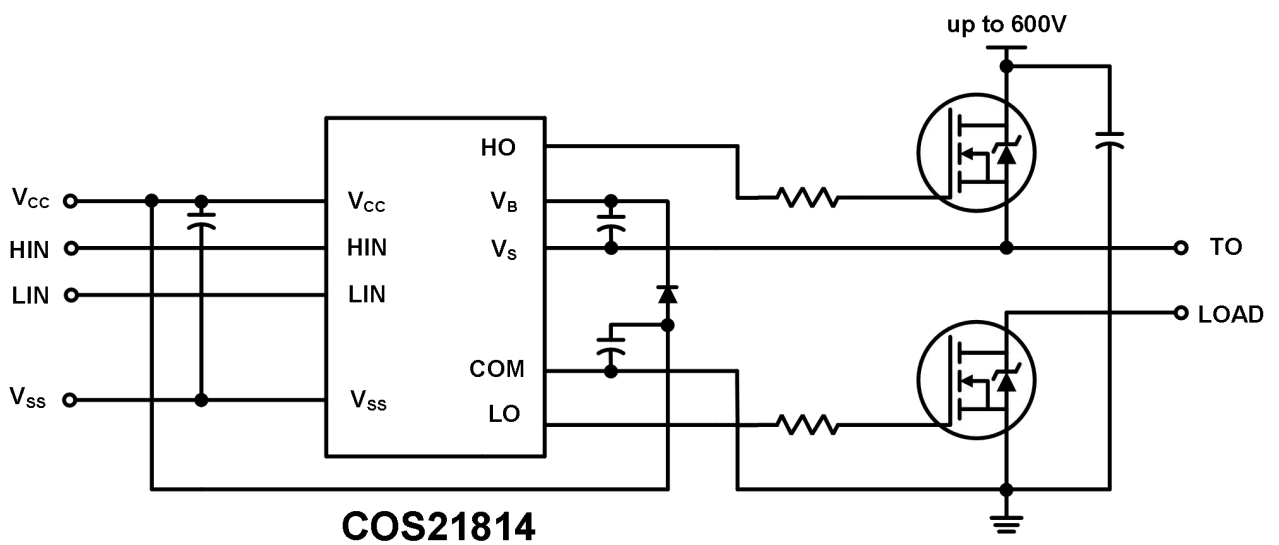

Figure 5. COS21814 Typical Connection

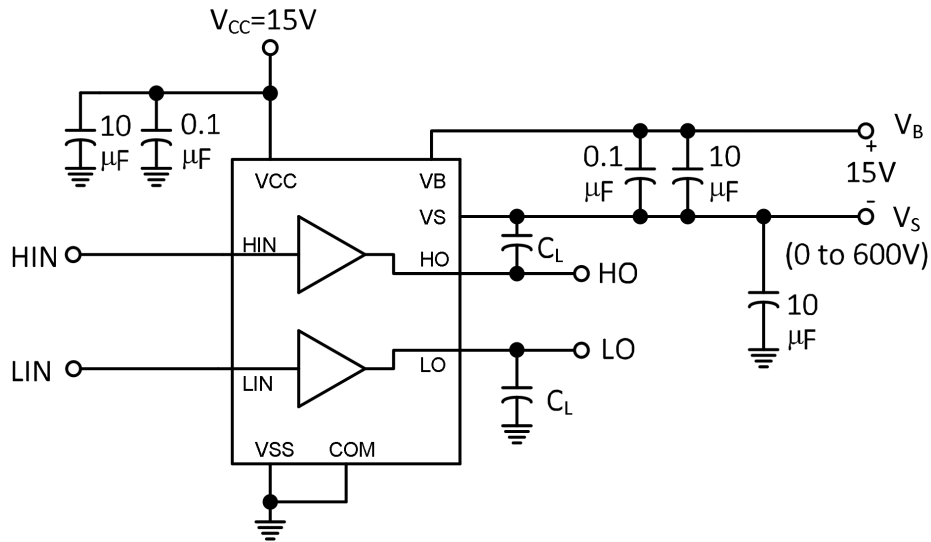

Figure 6. Switching Time Test Circuit

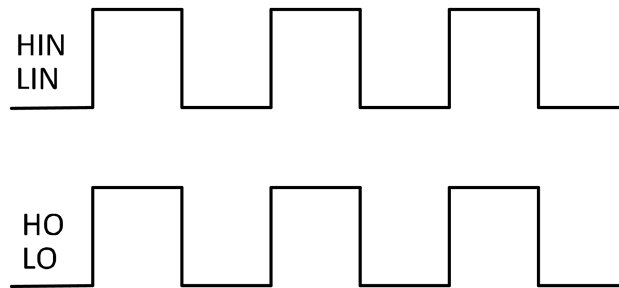

Figure 7. Input/Output Timing Diagram

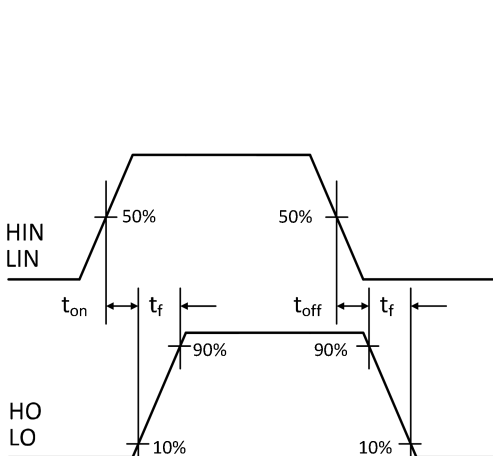

Figure 8. Switching Time Waveform Definition

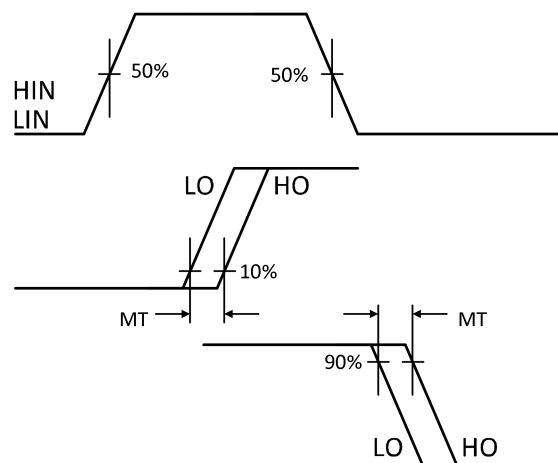
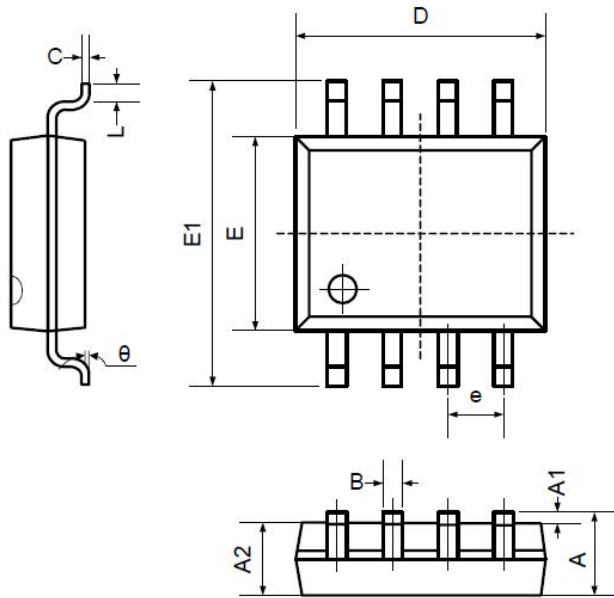

Figure 9. Delay Matching Waveform Definition

4. Package Information

4.1 SOP8 (Package Outline Dimensions)



Symbol	Dimensions In Millimeters		Dimensions In Inches	
	Min	Max	Min	Max
A	1.350	1.750	0.053	0.069
A1	0.100	0.250	0.004	0.010
A2	1.350	1.550	0.053	0.061
B	0.330	0.510	0.013	0.020
C	0.190	0.250	0.007	0.010
D	4.780	5.000	0.188	0.197
E	3.800	4.000	0.150	0.157
E1	5.800	6.300	0.228	0.248
e	1.270TYP		0.050TYP	
L	0.400	1.270	0.016	0.050
θ	0°	8°	0°	8°

4.2 DIP8 (Package Outline Dimensions)

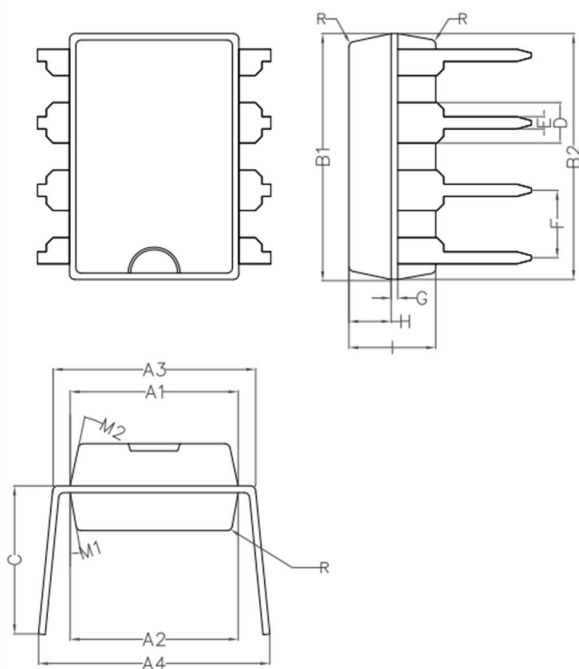

Symbol	Min	Non	Max
A1	6.28	6.33	6.38
A2	6.33	6.38	6.43
A3	7.52	7.62	7.72
A4	7.80	8.40	9.00
B1	9.15	9.20	9.25
B2	9.20	9.25	9.30
C		5.57	
D		1.52	
E	0.43	0.45	0.47
F		2.54	
G		0.25	
H	1.54	1.59	1.64
I	3.22	3.27	3.32
R		0.20	
M1	9°	10°	11°
M2	11°	12°	13°

5. Ordering Information

Model	Order Number	Package	Package Option	Marking Information
COS2181	COS2181STRPBF	SOP-8	Tape and Reel, 4000	COS2181
	COS2181PBF	DIP-8	Tube 50	COS2181
COS21814	COS21814STRPBF	SOP-14	Tape and Reel, 3000	COS21814
	COS21814PBF	DIP-14	Tube 25	COS21814

单击下面可查看定价，库存，交付和生命周期等信息

[>>COSINE\(科山芯创\)](#)