

Power TVS in DO-214AA/SMB

Features

- Glass passivated chip
- 600W peak pulse power(10/1000us)
- High accuracy, 5% tolerance
- Uni and Bidirectional unit
- Low clamping voltage
- Low Leakage current
- Very fast response time
- JESD22-A114-B ESD Voltage:HBM 15KV
- JEDEC EIA/JESD22-C101F ESD Voltage:CDM 500V
- JEDEC EIA/JESD22-A115 ESD Voltage:MM 400V
- ESD-immunity acc. IEC 61000-4-2 ±30KV contact ±30KV air
- Base P/N-HM AEC-Q101 qualified

Mechanical Data

- **Case:** DO-214AA/SMB (plastic package).
RoHS compliant
- **Molding Compound Flammability Rating:**
UL 94 V-0
- **Terminals:** High temperature soldering guaranteed:
260 °C/10 sec. at terminals



Bidirectional

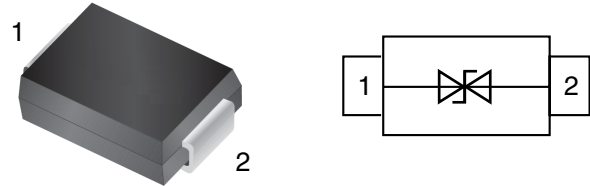

Unidirectional

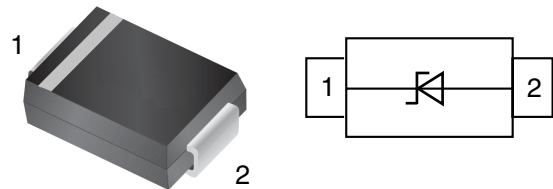

Applications

- Computers
- Telecom system
- Industrial equipments
- Consumer electronic applications
- Other VCC bus and I/O interfaces

Absolute Maximum Ratings

Ratings at 25 °C, ambient temperature unless otherwise specified

Parameter	Symbol	Value	Unit
Peak pulse power dissipation with a 10/1000us waveform ⁽¹⁾	P _{PP}	600	W
Maximum peak reverse pulse current a 10/1000us waveform ⁽¹⁾	I _{PP}	See Next Table	A
Peak forward surge current 8.3ms single half sine-wave ⁽²⁾	I _{FSM}	100	A
Operating junction and storage temperature range	T _J , T _{STG}	-55 to +150	°C

Notes:

- 1.Non-repetitive current pulse,per Fig.5 and detated above TA=25°C per Fig.1
- 2.Measured on 8.3ms single half sine-wave,or equivalent square wave,duty cycle=4 pulses per minute maximum

Electrical Characteristics

(T_A = 25 °C unless otherwise specified)

Part No.		Device marking code		Breakdown voltage V _(BR) (Volts) ⁽¹⁾		Test current at I _T (mA)	Stand-off voltage V _{WM} (Volts)	Maximum reverse leakage at V _{WM} I _b ⁽³⁾ (uA)	Maximum peak pulse current I _{PPM} ⁽²⁾ (A)	Maximum clamping voltage at I _{PPM} V _C (Volts)	Maximum temperature coefficient of V _(BR) (%/°C)
		UNI	BI	Min.	Max.						
P6SMB6.8A	P6SMB6.8CA	6V8A	6V8C	6.45	7.14	10	5.80	1000	57.1	10.5	0.057
P6SMB7.5A	P6SMB7.5CA	7V5A	7V5C	7.13	7.88	10	6.40	500	53.1	11.3	0.061
P6SMB8.2A	P6SMB8.2CA	8V2A	8V2C	7.79	8.61	10	7.02	200	49.6	12.1	0.065
P6SMB9.1A	P6SMB9.1CA	9V1A	9V1C	8.65	9.55	1.0	7.78	50	44.8	13.4	0.068
P6SMB10A	P6SMB10CA	10A	10C	9.50	10.5	1.0	8.55	10	41.4	14.5	0.073
P6SMB11A	P6SMB11CA	11A	11C	10.5	11.6	1.0	9.40	5.0	38.5	15.6	0.075
P6SMB12A	P6SMB12CA	12A	12C	11.4	12.6	1.0	10.2	5.0	35.9	16.7	0.078
P6SMB13A	P6SMB13CA	13A	13C	12.4	13.7	1.0	11.1	5.0	33.0	18.2	0.081
P6SMB15A	P6SMB15CA	15A	15C	14.3	15.8	1.0	12.8	1.0	28.3	21.2	0.084
P6SMB16A	P6SMB16CA	16A	16C	15.2	16.8	1.0	13.6	1.0	26.7	22.5	0.086
P6SMB18A	P6SMB18CA	18A	18C	17.1	18.9	1.0	15.3	1.0	23.8	25.2	0.088
P6SMB20A	P6SMB20CA	20A	20C	19.0	21.0	1.0	17.1	1.0	21.7	27.7	0.090
P6SMB22A	P6SMB22CA	22A	22C	20.9	23.1	1.0	18.8	1.0	19.6	30.6	0.092
P6SMB24A	P6SMB24CA	24A	24C	22.8	25.2	1.0	20.5	1.0	18.1	33.2	0.094
P6SMB27A	P6SMB27CA	27A	27C	25.7	28.4	1.0	23.1	1.0	16.0	37.5	0.096
P6SMB30A	P6SMB30CA	30A	30C	28.5	31.5	1.0	25.6	1.0	14.5	41.4	0.097
P6SMB33A	P6SMB33CA	33A	33C	31.4	34.7	1.0	28.2	1.0	13.1	45.7	0.098
P6SMB36A	P6SMB36CA	36A	36C	34.2	37.8	1.0	30.8	1.0	12.0	49.9	0.099
P6SMB39A	P6SMB39CA	39A	39C	37.1	41.0	1.0	33.3	1.0	11.1	53.9	0.100
P6SMB43A	P6SMB43CA	43A	43C	40.9	45.2	1.0	36.8	1.0	10.1	59.3	0.101
P6SMB47A	P6SMB47CA	47A	47C	44.7	49.4	1.0	40.2	1.0	9.3	64.8	0.101
P6SMB51A	P6SMB51CA	51A	51C	48.5	53.6	1.0	43.6	1.0	8.6	70.1	0.102
P6SMB56A	P6SMB56CA	56A	56C	53.2	58.8	1.0	47.8	1.0	7.8	77.0	0.103
P6SMB62A	P6SMB62CA	62A	62C	58.9	65.1	1.0	53.0	1.0	7.1	85.0	0.104
P6SMB68A	P6SMB68CA	68A	68C	64.6	71.4	1.0	58.1	1.0	6.5	92.0	0.104
P6SMB75A	P6SMB75CA	75A	75C	71.3	78.8	1.0	64.1	1.0	5.8	103	0.105
P6SMB82A	P6SMB82CA	82A	82C	77.9	86.1	1.0	70.1	1.0	5.3	113	0.105
P6SMB91A	P6SMB91CA	91A	91C	86.5	95.5	1.0	77.8	1.0	4.8	125	0.106
P6SMB100A	P6SMB100CA	100A	100C	95.0	105	1.0	85.5	1.0	4.4	137	0.106
P6SMB110A	P6SMB110CA	110A	110C	105	116	1.0	94.0	1.0	3.9	152	0.107
P6SMB120A	P6SMB120CA	120A	120C	114	126	1.0	102	1.0	3.6	165	0.107
P6SMB130A	P6SMB130CA	130A	130C	124	137	1.0	111	1.0	3.4	179	0.107
P6SMB150A	P6SMB150CA	150A	150C	143	158	1.0	128	1.0	2.9	207	0.108
P6SMB160A	P6SMB160CA	160A	160C	152	168	1.0	136	1.0	2.7	219	0.108
P6SMB170A	P6SMB170CA	170A	170C	162	179	1.0	145	1.0	2.6	234	0.108
P6SMB180A	P6SMB180CA	180A	180C	171	189	1.0	154	1.0	2.4	246	0.108
P6SMB200A	P6SMB200CA	200A	200C	190	210	1.0	171	1.0	2.2	274	0.108
P6SMB220A	P6SMB220CA	220A	220C	209	231	1.0	185	1.0	1.9	328	0.108
P6SMB250A	P6SMB250CA	250A	250C	237	263	1.0	214	1.0	1.8	344	0.108
P6SMB300A	P6SMB300CA	300A	300C	285	315	1.0	256	1.0	1.5	414	0.108

Part No.		Device marking code		Breakdown voltage $V_{(BR)}$ (Volts) ⁽¹⁾		Test current I_T (mA)	Stand-off voltage V_{WM} (Volts)	Maximum reverse leakage at V_{WM} $I_D^{(3)}$ (uA)	Maximum peak pulse current $I_{PPM}^{(2)}$ (A)	Maximum clamping voltage at I_{PPM} V_C (Volts)	Maximum temperature coefficient of $V_{(BR)}$ (%/°C)
		UNI	BI	Min.	Max.						
P6SMB350A	P6SMB350CA	350A	350C	332	368	1.0	300	1.0	1.3	482	0.108
P6SMB400A	P6SMB400CA	400A	400C	380	420	1.0	342	1.0	1.1	548	0.108
P6SMB440A	P6SMB440CA	440A	440C	418	462	1.0	376	1.0	1.0	602	0.108
P6SMB480A	P6SMB480CA	480A	480C	456	504	1.0	408	1.0	0.9	658	0.108
P6SMB510A	P6SMB510CA	510A	510C	485	535	1.0	434	1.0	0.9	698	0.108
P6SMB530A	P6SMB530CA	530A	530C	503.5	556.5	1.0	451	1.0	0.8	725	0.108
P6SMB540A	P6SMB540CA	540A	540C	513	567	1.0	460	1.0	0.8	740	0.108
P6SMB550A	P6SMB550CA	550A	550C	522.5	577.5	1.0	468	1.0	0.8	760	0.108

- Notes:**
1. $V_{(BR)}$ measured after I_T applied for 300us, I_T =square wave pulse or equivalent
 2. Surge current waveform per Fig. 3 and derate per Fig. 2
 3. For bidirectional types with V_{WM} of 10 Volts and less, the I_D limit is doubled
 4. All terms and symbols are consistent with ANSI/IEEE C62.35

Typical Characteristics ($T_{amb} = 25\text{ }^{\circ}\text{C}$ unless otherwise specified)

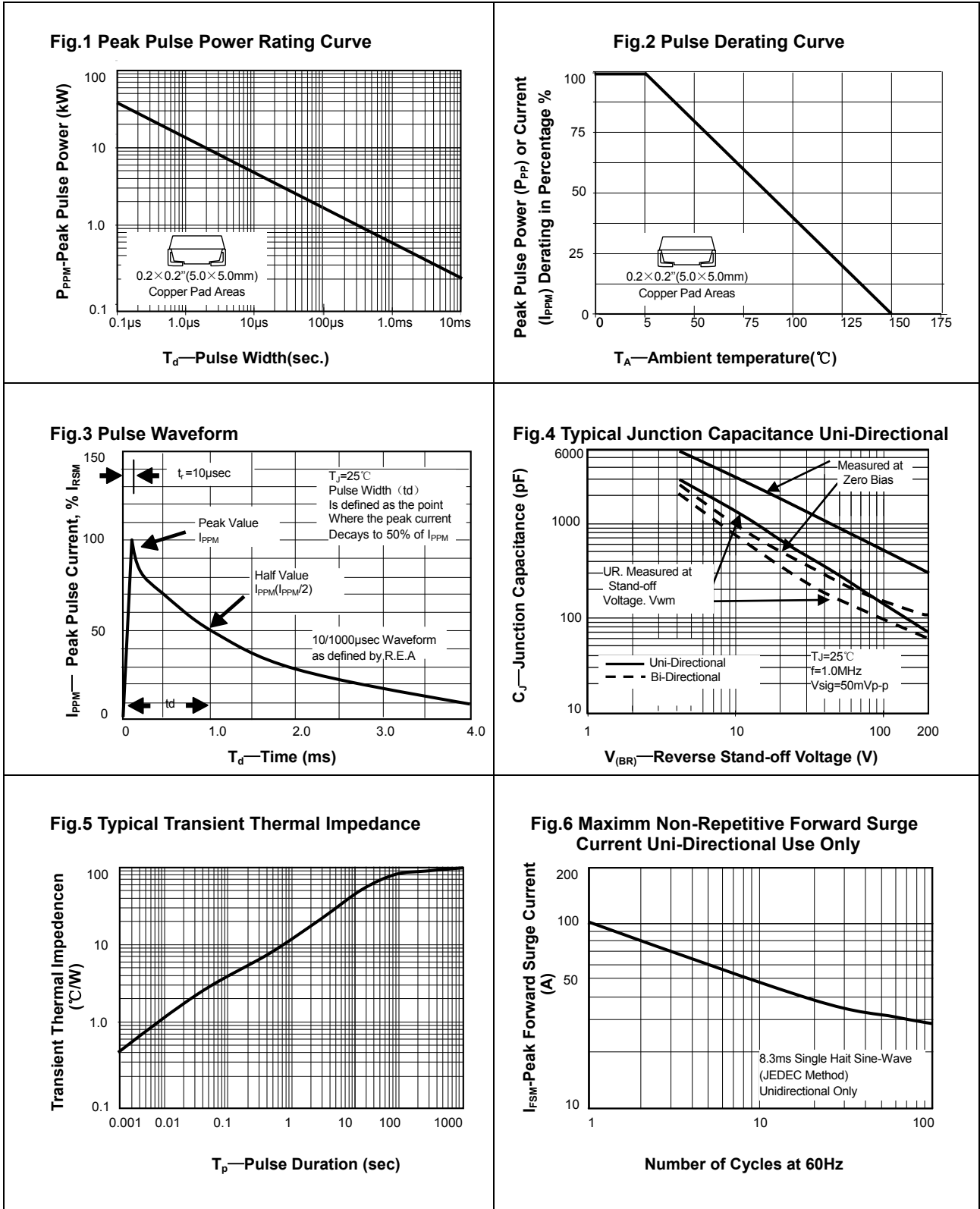

Package Dimensions

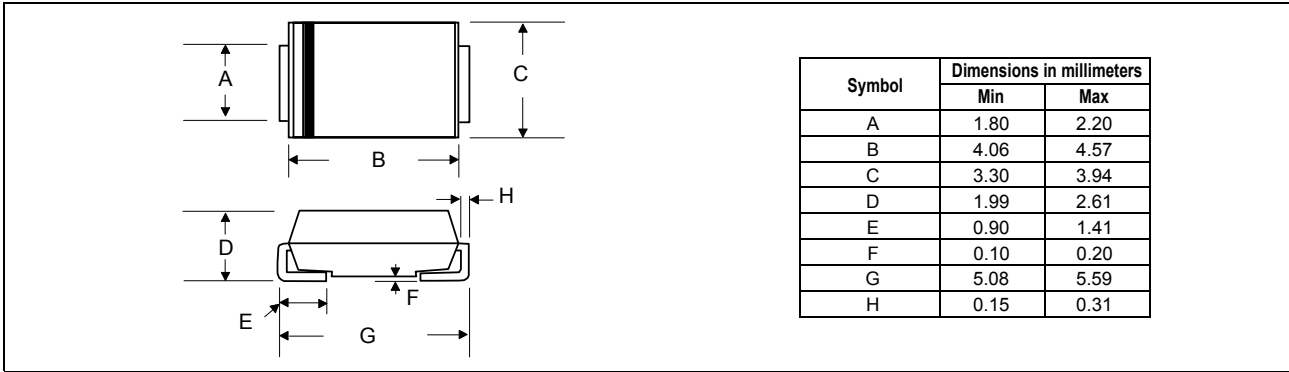

PAD Dimensions

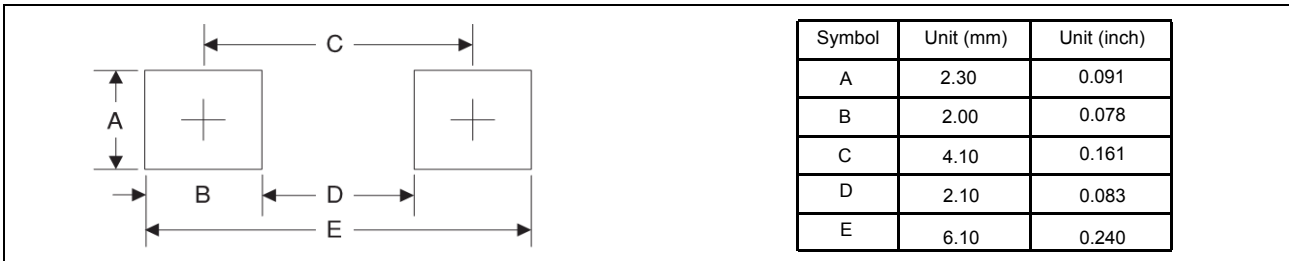

Packing Information

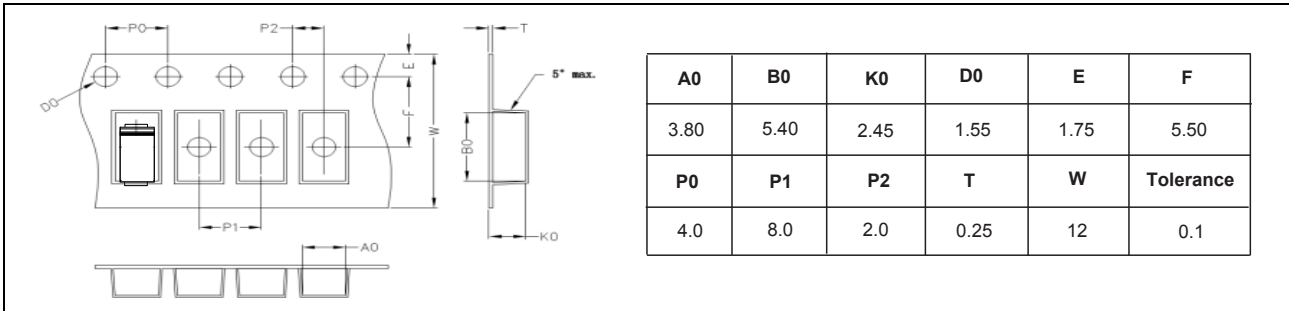

Marking

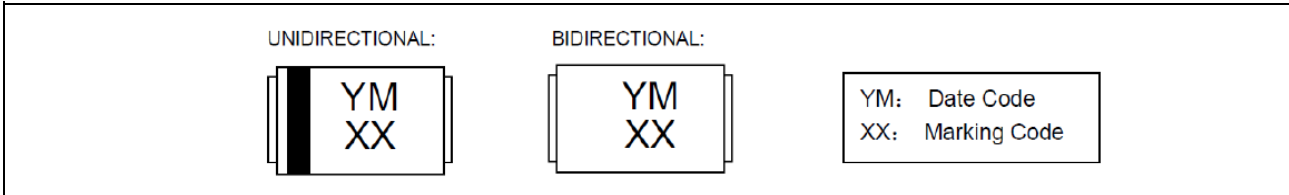

Ordering information

Order code	Package	Packaging option	Base quantity	Packaging specification
P6SMB Series	DO-214AA/SMB	Tape and reel	3000pcs / reel	EIA STD RS-481

Revision history

Date	Revision	Changes
5-Jul.-2021	3.0	Update

CAUTION / WARNING

Information in this document is believed to be accurate and reliable. However, CREATEK does not give any representations or warranties, expressed or implied, as to the accuracy or completeness of such information and shall have no liability for the consequences of use of such information.

Users should independently evaluate the suitability of and test each product selected for their own applications, and CREATEK assumes no liability whatsoever relating to the choice, selection or use of the CREATEK products and services described herein.

CREATEK reserves the right to change or update, without notice, any information contained in this publication; to change, without notice, the design, construction, processing, or specification of any product; and to discontinue or limit production or distribution of any product.

Information in this document supersedes and replaces all information previously supplied.

Products are not designed, authorized or warranted to be suitable for use in medical, military, aircraft, space or life support equipment, nor in applications where failure or malfunction of an CREATEK product can reasonably be expected to result in personal injury, death or severe property or environmental damage. CREATEK accepts no liability for inclusion and/or use of CREATEK products in such equipment or applications and therefore such inclusion and/or use is at the customer's own risk.

This document as well as the item(s) described herein may be subject to export control regulations. Export might require a prior authorization from national authorities.

Resale of CREATEK products with provisions different from the statements and/or technical features set forth in this document shall immediately void any warranty granted by CREATEK for the CREATEK product or service described herein and shall not create or extend in any manner whatsoever, any liability of CREATEK.

CREATEK expressly disclaims all implied warranties regarding the information contained herein, including, but not limited to, any implied warranties of merchantability or fitness for a particular purpose. CREATEK only obligations are those in the CREATEK Standard Terms and Conditions of Sale and in no case will CREATEK be liable for any incidental, indirect, or consequential damages arising from the sale, resale, use, or misuse of its products.

Specifications are subject to change without notice

© Copyright 2009, CREATEK Microelectronics

 CREATEK® is a registered trademark of CREATEK Microelectronics

All rights reserved

单击下面可查看定价，库存，交付和生命周期等信息

[>>CREATEK](#)