

Features

- Uses CRM(CQ) advanced SkyMOS4 technology
- Extremely low on-resistance $R_{DS(on)}$
- Excellent $Q_g \times R_{DS(on)}$ product(FOM)
- Qualified according to JEDEC criteria

Applications

- Synchronous Rectification for AC/DC Quick Charger
- Battery management
- UPS (Uninterruptible Power Supplies)

Product Summary

V_{DS}	80V
$R_{DS(on)@10V}$ typ	3.1mΩ
I_D	80A

100% Avalanche Tested
100% DVDS Tested

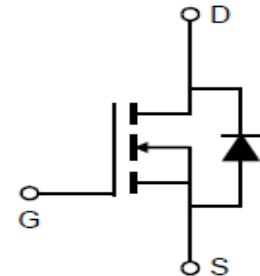
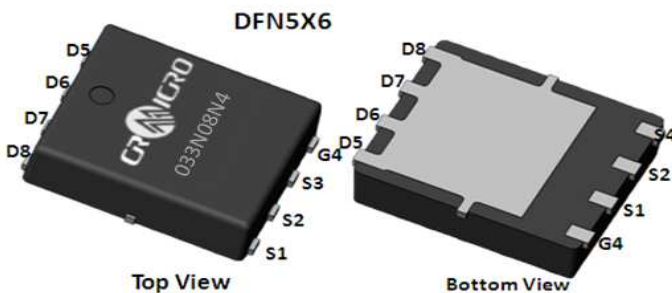
Package Marking and Ordering Information

Part #	Marking	Package	Packing	Reel Size	Tape Width	Qty
CRSM033N08N4	033N08N4	DFN5X6 clip	Tape&Reel	N/A	N/A	4000pcs

Absolute Maximum Ratings

Parameter	Symbol	Value	Unit
Drain-source voltage	V_{DS}	80	V
Continuous drain current	I_D	143	A
$T_C = 25^\circ\text{C}$		80	
$T_C = 25^\circ\text{C}$ (Package limit)		90	
Pulsed drain current ($T_C = 25^\circ\text{C}$, t_p limited by T_{jmax})	$I_{D\ pulse}$	320	A
Avalanche energy, single pulse ($I_D=29A$, $R_g=25\Omega$)	E_{AS}	126	mJ
Gate-Source voltage	V_{GS}	± 20	V
Power dissipation ($T_C = 25^\circ\text{C}$)	P_{tot}	139	W
Operating junction and storage temperature	T_j, T_{stg}	-55...+150	$^\circ\text{C}$
Soldering temperature, wave soldering only allowed at leads (1.6mm from case for 10s)	T_{sold}	260	$^\circ\text{C}$

Thermal Resistance

Parameter	Symbol	Value			Unit	Test Condition
		min.	typ.	max.		
Thermal resistance, junction – case.	RthJC	-	0.5	0.90	°C/W	-
Thermal resistance, junction - ambient(min. footprint)	RthJA	-	-	55	°C/W	-

Electrical Characteristic (at Tj = 25 °C, unless otherwise specified)

Parameter	Symbol	Value			Unit	Test Condition
		min.	typ.	max.		

Static Characteristic

Drain-source breakdown voltage	BV _{DSS}	80	-	-	V	V _{GS} =0V, I _D =250uA
Gate threshold voltage	V _{GS(th)}	2.2	3	3.8	V	V _{DS} =V _{GS} , I _D =250uA
Zero gate voltage drain current	I _{DSS}	-	-	1	μA	V _{DS} =80V, V _{GS} =0V T _j =25°C
		-	-	100		T _j =125°C
Gate-source leakage current	I _{GSS}		-	±100	nA	V _{GS} =±20V, V _{DS} =0V
Drain-source on-state resistance	R _{DS(on)}	-	3.1	3.7	mΩ	V _{GS} =10V, I _D =50A
		-	3.3	4.1	mΩ	V _{GS} =8V, I _D =40A
Transconductance	g _{fs}	-	162	-	S	V _{DS} =5V, I _D =50A

Dynamic Characteristic

Input Capacitance	C _{iss}	3440	5160	7740	pF	V _{GS} =0V, V _{DS} =40V, f=1MHz
Output Capacitance	C _{oss}	1171.33	1757	2635.5		
Reverse Transfer Capacitance	C _{rss}	23	46	92		
Gate Total Charge	Q _G	47	70	105	nC	V _{GS} =10V, V _{DS} =40V, I _D =50A, f=1MHz
Gate-Source charge	Q _{gs}	16	24	36		
Gate-Drain charge	Q _{gd}	6	11	22		
Turn-on delay time	t _{d(on)}	13	19	28.5	ns	V _{GS} =10V, V _{DD} =40V, R _{G_ext} =2.7Ω
Rise time	t _r	57	85	128		
Turn-off delay time	t _{d(off)}	28	42	63		
Fall time	t _f	56	84	126		
Gate resistance	R _G	-	1.8	2.7	Ω	V _{GS} =0V, V _{DS} =0V, f=1MHz

Body Diode Characteristic

Parameter	Symbol	Value			Unit	Test Condition
		min.	typ.	max.		
Body Diode Forward Voltage	V_{SD}	-	0.82	1.4	V	$V_{GS}=0V, I_{SD}=50A$
Body Diode Continuous Forward Current	I_S	-	-	80	A	TC = 25°C
Body Diode Pulsed Current	I_S pulse	-	-	320	A	TC = 25°C
Body Diode Reverse Recovery Time	t_{rr}	-	63	126	ns	$I_F=50A, dI/dt=100A/\mu$ s
Body Diode Reverse Recovery Charge	Q_{rr}	-	105	210	nC	

Typical Performance Characteristics

Fig 1: Output Characteristics

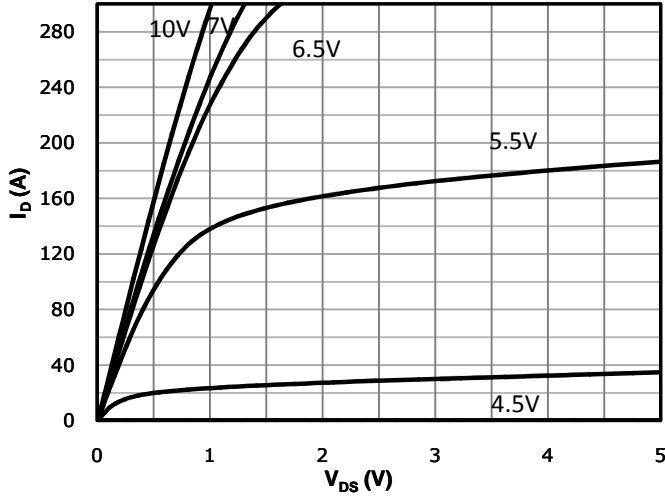

Fig 2: Transfer Characteristics

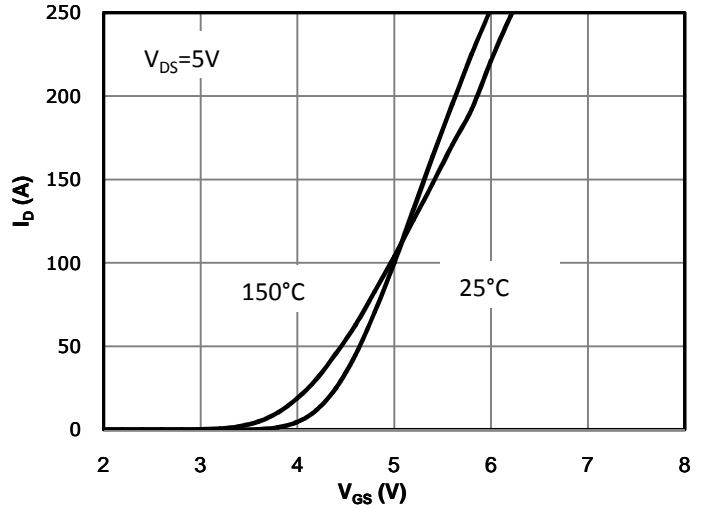

Fig 3: Rds(on) vs Drain Current and Gate Voltage

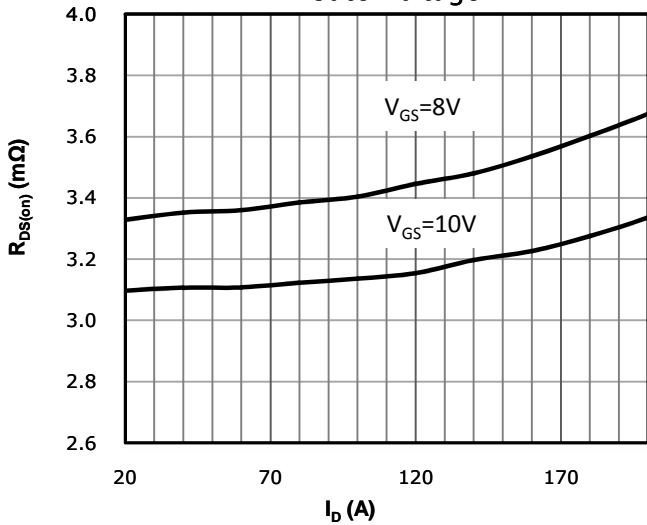

Fig 4: Rds(on) vs Gate Voltage

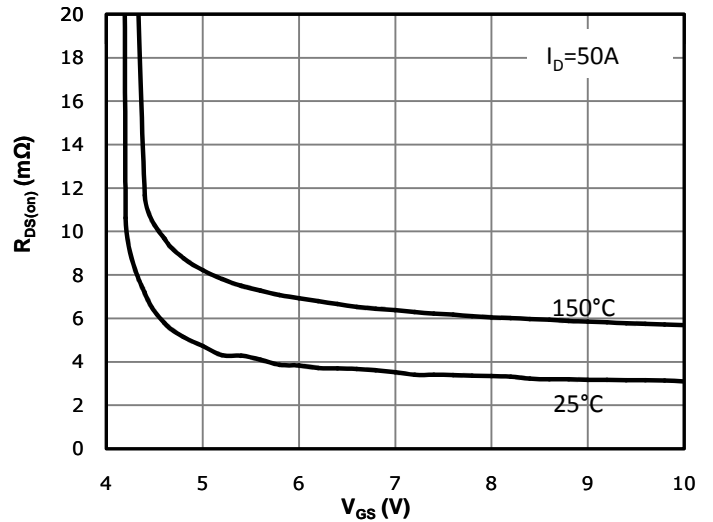

Fig 5: Rds(on) vs. Temperature

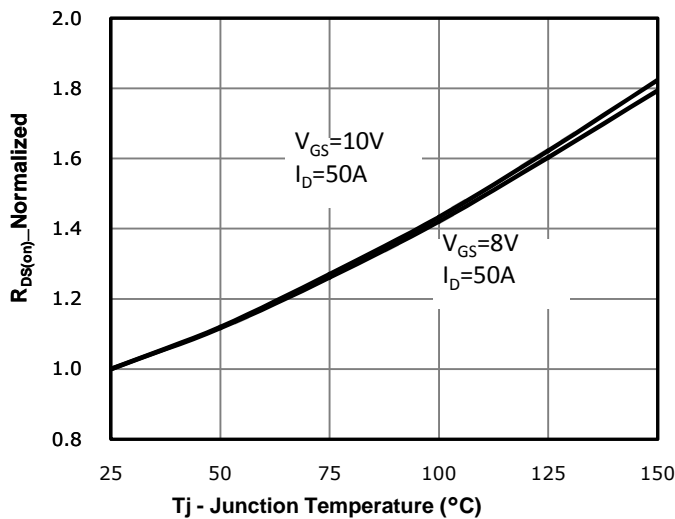

Fig 6: Capacitance Characteristics

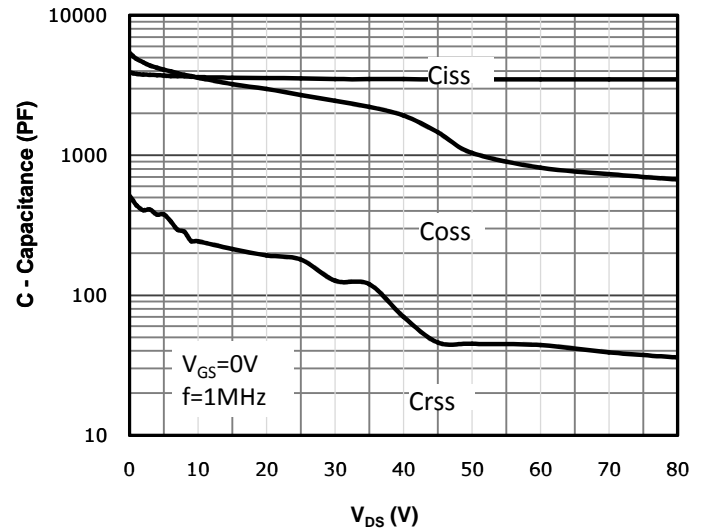

Fig 7: Gate Charge Characteristics

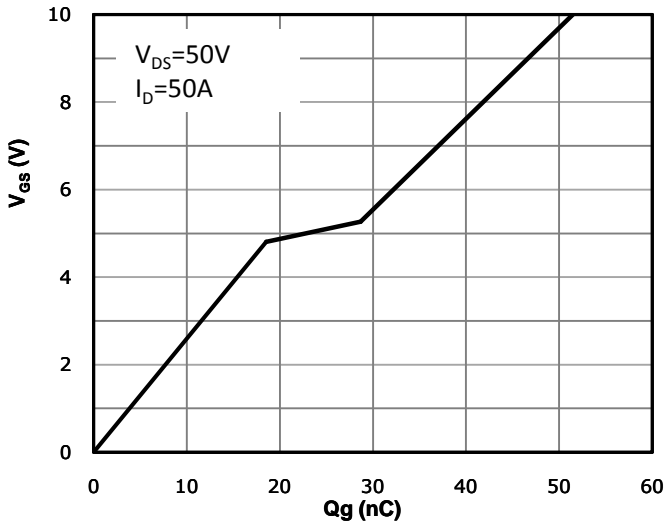

Fig 8: Body-diode Forward Characteristics

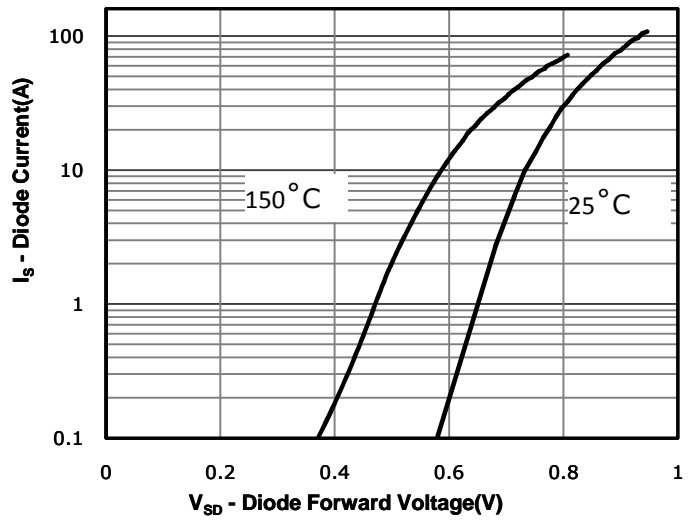

Fig 9: Power Dissipation

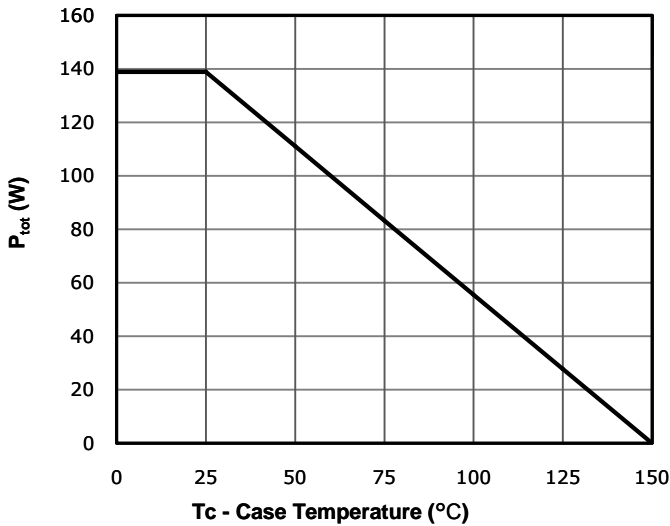

Fig 10: Drain Current Derating

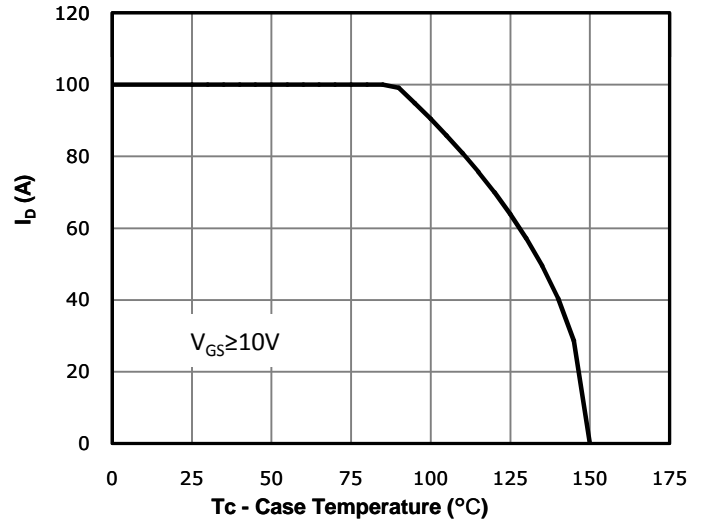

Fig 11: Safe Operating Area

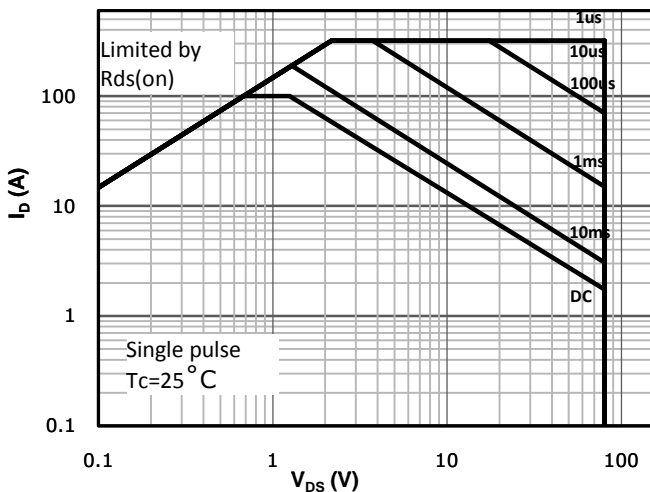
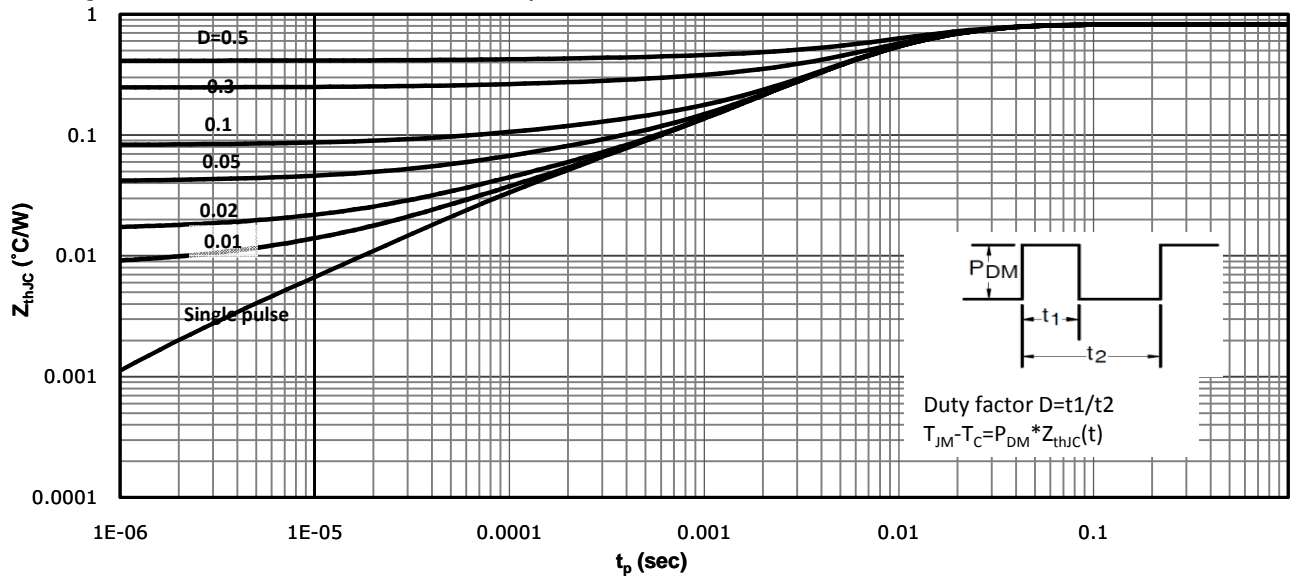
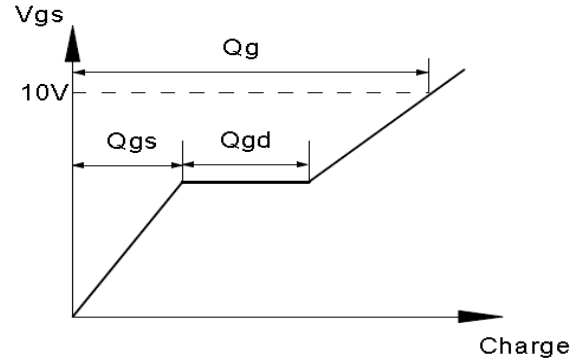
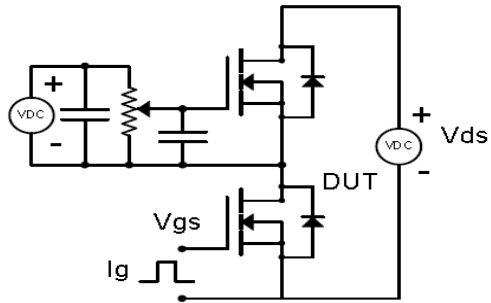

Fig 12: Max. Transient Thermal Impedance



Test Circuit & Waveform

Gate Charge Test Circuit & Waveform



Resistive Switching Test Circuit & Waveforms

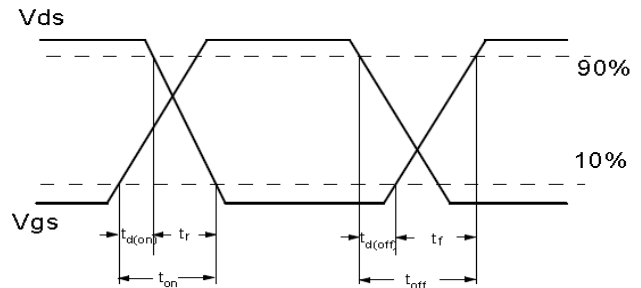
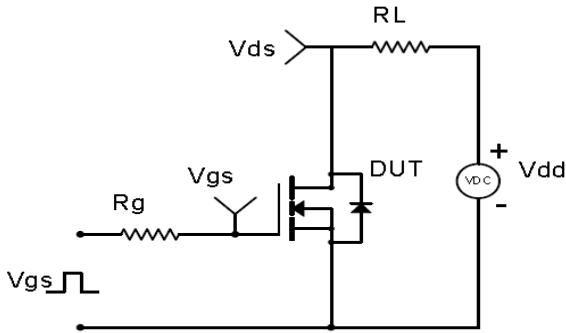

Unclamped Inductive Switching (UIS) Test Circuit & Waveforms

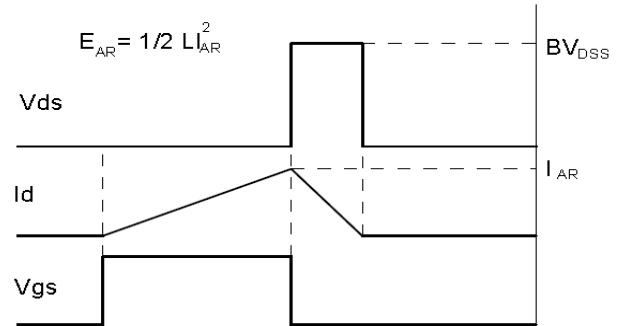
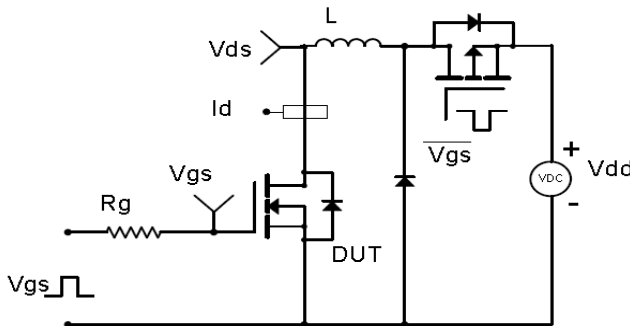

Diode Recovery Test Circuit & Waveforms

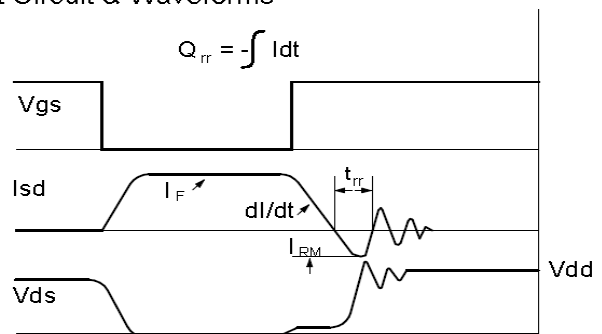
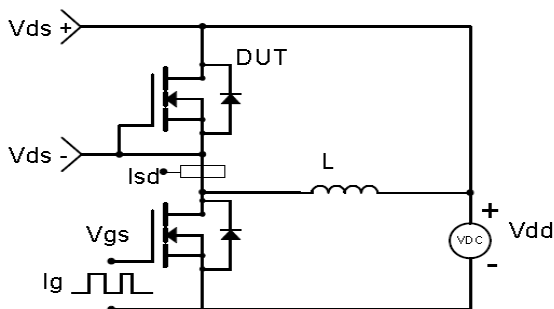

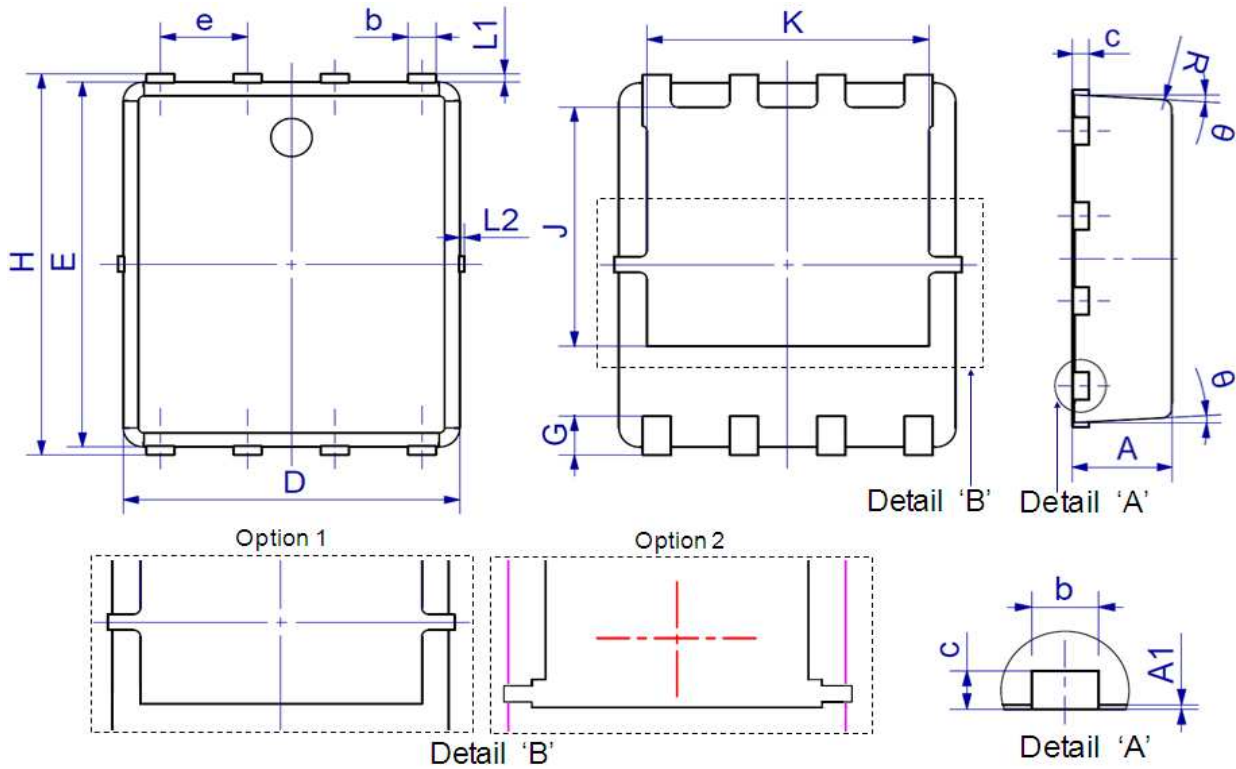
Package Outline: DFN5X6

Symbol	Dimensions In Millimeters		Dimensions In Inches	
	Min.	Max.	Min.	Max.
A	0.80	1.20	0.031	0.047
A1	0.00	0.05	0.000	0.002
b	0.30	0.51	0.012	0.020
c	0.15	0.35	0.006	0.014
D	4.80	5.40	0.189	0.213
e	1.27 BSC		0.050 BSC	
E	5.66	6.06	0.223	0.239
G	0.30	0.71	0.012	0.028
H	5.90	6.35	0.232	0.250
J	3.32	3.92	0.131	0.154
K	3.61	4.25	0.142	0.167
L1	0.05	0.25	0.002	0.010
L2	0.00	0.15	0.000	0.006
R	0.25 REF		0.010 REF	
θ	0°	12°	0°	12°

Marking



NOTE:

NXBBAAAAY

N	—Wire Bond code
X	—Assembly location code
BB	—Fab code
AAAA	—Lot code
Y	—Bin code

Revision History

Revision	Date	Major changes
1.0	2020-9-27	Release of Preliminary Version.

Disclaimer

Unless otherwise specified in the datasheet, the product is designed and qualified as a standard commercial product and is not intended for use in applications that require extraordinary levels of quality and reliability, such as automotive, aviation/aerospace and life-support devices or systems.

Any and all semiconductor products have certain probability to fail or malfunction, which may result in personal injury, death or property damage. Customer are solely responsible for providing adequate safe measures when design their systems.

CRM(CQ) reserves the right to improve product design, function and reliability without notice.

单击下面可查看定价，库存，交付和生命周期等信息

[>>CRMICRO\(华润微\)](#)