

Features

- Uses CRM(CQ) advanced Trench technology
- Extremely low on-resistance $R_{DS(on)}$
- Excellent $Q_g \times R_{DS(on)}$ product(FOM)

Product Summary

Symbol	P-Ch1	P-Ch2
V_{DS}	-30V	-30V
$R_{DS(on)}$ typ.	50m Ω	50m Ω
I_D	-5A	-5A

Applications

- Motor drive

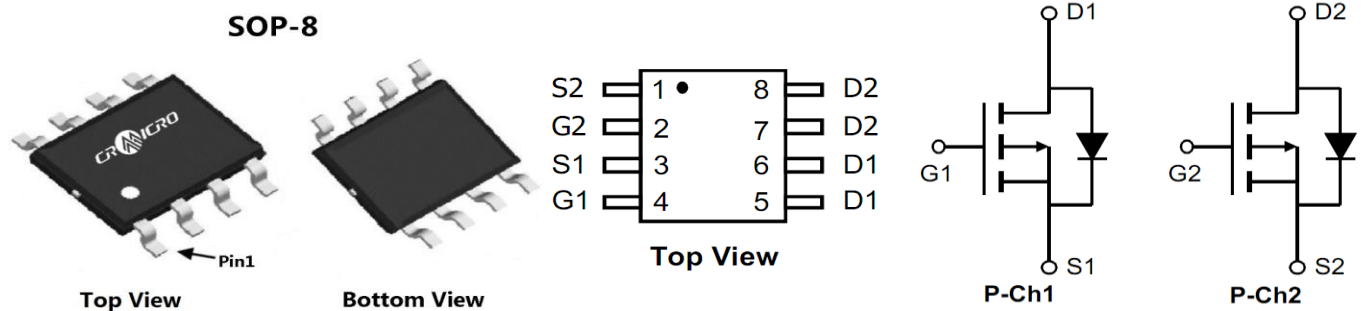
100% DVDS Tested
100% Avalanche Tested

Package Marking and Ordering Information

Part #	Marking	Package	Packing	Reel Size	Tape Width	Qty
CRMM4953D	CRMM4953D	SOP-8	Taping	N/A	N/A	4000pcs

Absolute Maximum Ratings

Parameter	Symbol	Maximum		Unit
		P-Ch1	PCh2	
Drain-source voltage	V_{DS}	-30	-30	V
Continuous drain current $T_C = 25^\circ\text{C}$ (Silicon limit)	I_D	-5	-5	A
Continuous drain current $T_C = 25^\circ\text{C}$ (Package limit)	I_D	-5	-5	A
Pulsed drain current ($T_C = 25^\circ\text{C}$, t_p limited by T_{jmax})	$I_{D\ pulse}$	-22	-22	A
Avalanche energy, single pulse ($L=0.5\text{mH}$, $R_g=25\Omega$)	E_{AS}	23	23	mJ
Gate-Source voltage	V_{GS}	± 20	± 20	V
Power dissipation ($T_C = 25^\circ\text{C}$)	P_{tot}	2.8	2.8	W
Operating junction and storage temperature	T_j, T_{stg}	-55...+150		$^\circ\text{C}$

Thermal Resistance

Parameter	Symbol	Typ	Max	Unit
Thermal resistance, junction – to-Lead.	R_{thJL}	32.1	44.9	$^{\circ}C/W$
SMD version, device on PCB ¹ Thermal resistance, junction – ambient(min. footprint)	R_{thJA}	79.6	103.5	$^{\circ}C/W$

NOTE:

1.The value of R_{thJA} is measured with the device mounted on 1in2 FR-4 board with 2oz. Copper, in a still air environment with $T_A = 25^{\circ}C$. The value in any given application depends on the user's specific board design.

P-Ch1&P-Ch2 Electrical Characteristic (at $T_j = 25^{\circ}C$, unless otherwise specified)

Parameter	Symbol	Value			Unit	Test Condition
		min.	typ.	max.		

Static Characteristic

Drain-source breakdown voltage	BV_{DSS}	-30	-	-	V	$V_{GS}=0V, I_D=-250\mu A$
Gate threshold voltage	$V_{GS(th)}$	-0.7	-1.2	-1.7	V	$V_{DS}=V_{GS}, I_D=-250\mu A$
Zero gate voltage drain current	I_{DSS}	-	-0.08	-1	μA	$V_{DS}=-30V, V_{GS}=0V$ $T_j=25^{\circ}C$
		-	-	-5		$T_j=125^{\circ}C$
Gate-source leakage current	I_{GSS}	-	± 10	± 100	nA	$V_{GS}=\pm 20V, V_{DS}=0V$
Drain-source on-state resistance	$R_{DS(on)}$	-	72.0	95.0	m Ω	$V_{GS}=-4.5V, I_D=-5A$
		-	50.0	60.0		$V_{GS}=-10V, I_D=-5A$
Transconductance	g_{fs}	-	11	-	S	$V_{DS}=-5V, I_D=-5A$

Dynamic Characteristic

Input Capacitance	C_{iss}	-	388	-	pF	$V_{GS}=0V, V_{DS}=-30V, f=1MHz$
Output Capacitance	C_{oss}	-	53	-		
Reverse Transfer Capacitance	C_{rss}	-	49	-		
Gate Total Charge	Q_G	-	11.2	-	nC	$V_{GS}=-10V, V_{DS}=-30V, I_D=-5A, f=1MHz$
Gate-Source charge	Q_{gs}	-	1.7	-		
Gate-Drain charge	Q_{gd}	-	3.2	-		
Turn-on delay time	$t_{d(on)}$	-	5.3	-	ns	$V_{GS}=-10V, V_{DD}=-15V, R_{G_ext}=2.7\Omega, I_D=-5A$
Rise time	t_r	-	42.3	-		
Turn-off delay time	$t_{d(off)}$	-	23.2	-		
Fall time	t_f	-	61.2	-		
Gate resistance	R_G	-	30.0	-	Ω	$V_{GS}=0V, V_{DS}=0V, f=1MHz$

Body Diode Characteristic

Parameter	Symbol	Value			Unit	Test Condition
		min.	typ.	max.		
Body Diode Forward Voltage	V_{SD}	-	-0.93	-1.20	V	$V_{GS}=0V, I_{SD}=-5A$
Body Diode Reverse Recovery Time	t_{rr}	-	13.9	-	ns	$I_F=5A, dI/dt=100A/\mu s$
Body Diode Reverse Recovery Charge	Q_{rr}	-	4.2	-	nC	

P-Ch1&P-Ch2 Typical Performance Characteristics

Fig 1: Output Characteristics

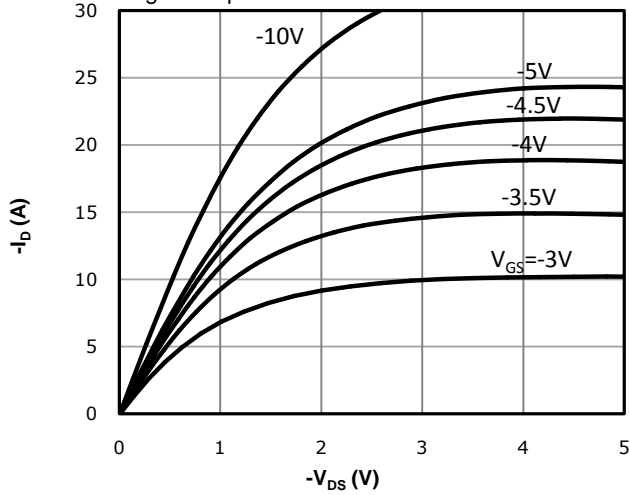

Fig 2: Transfer Characteristics

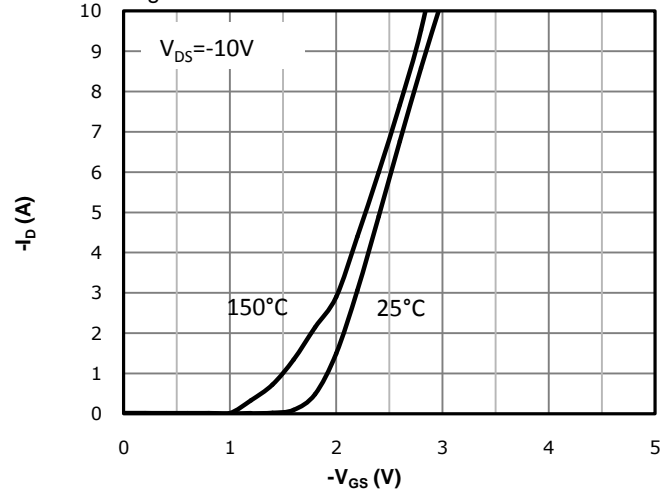

Fig 3: $R_{DS(on)}$ vs Drain Current and Gate Voltage

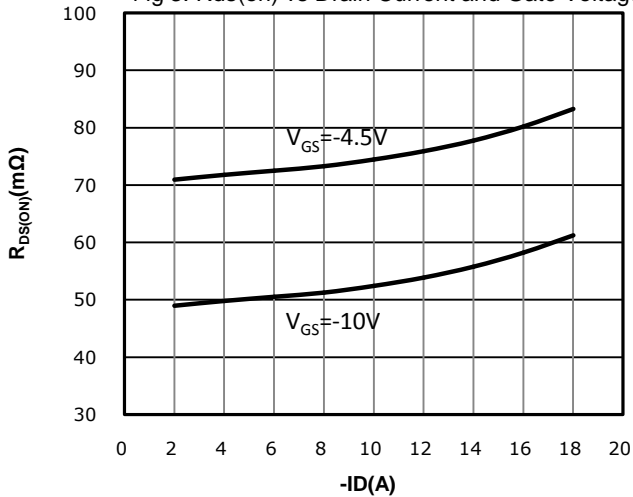
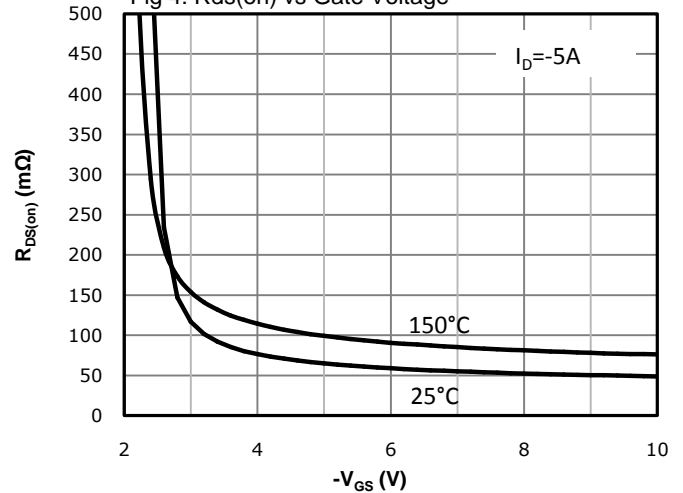

Fig 4: $R_{DS(on)}$ vs Gate Voltage



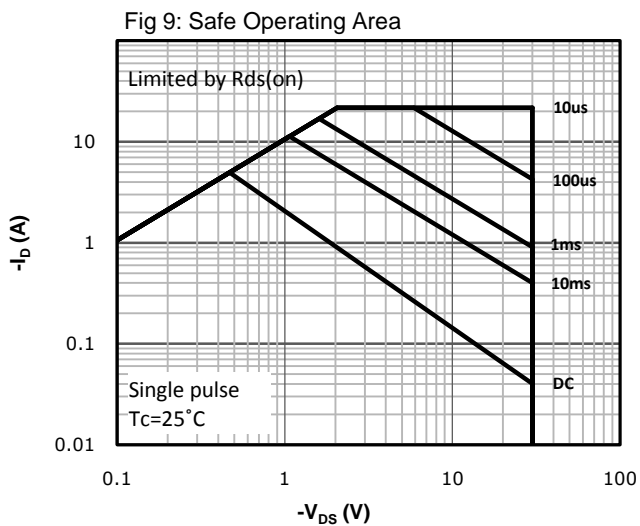
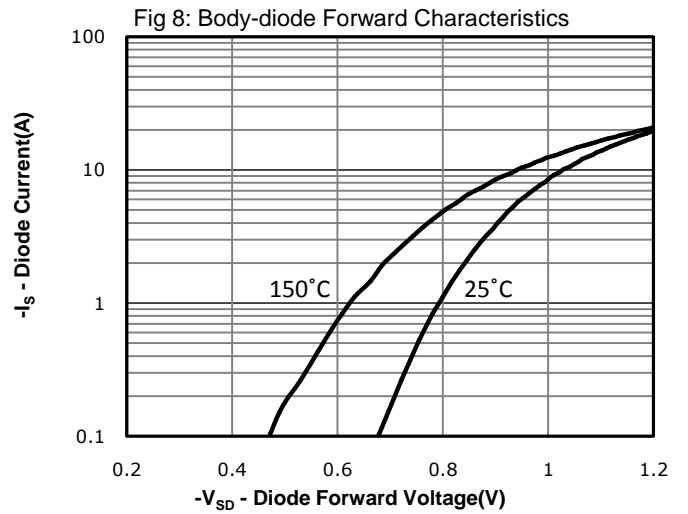
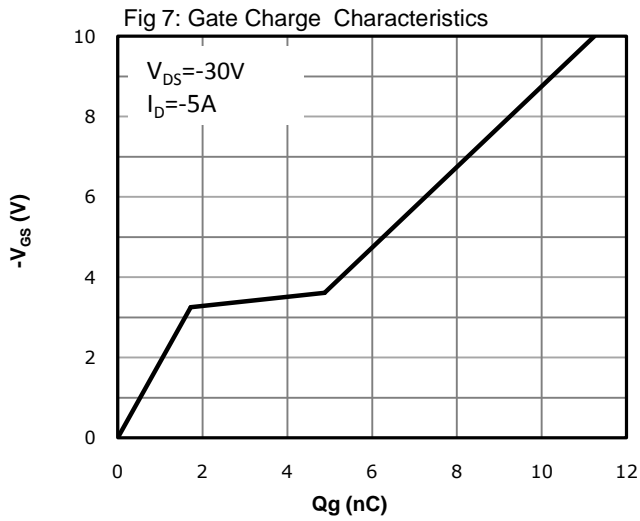
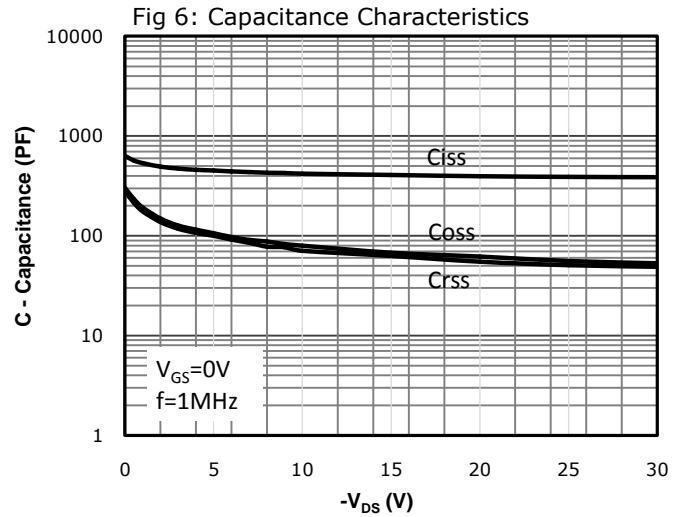
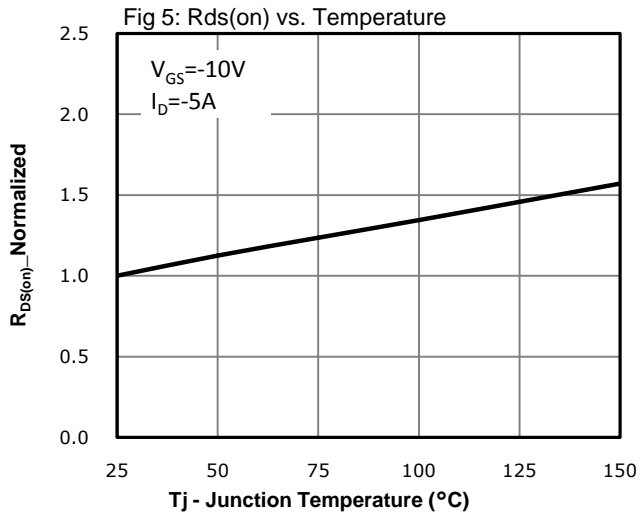
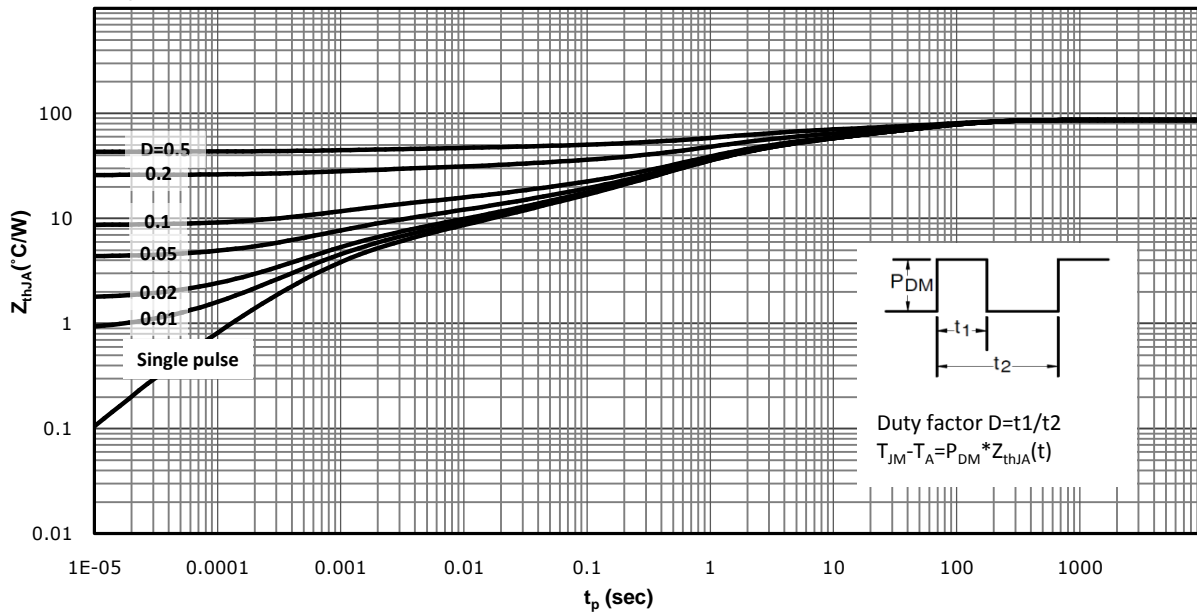
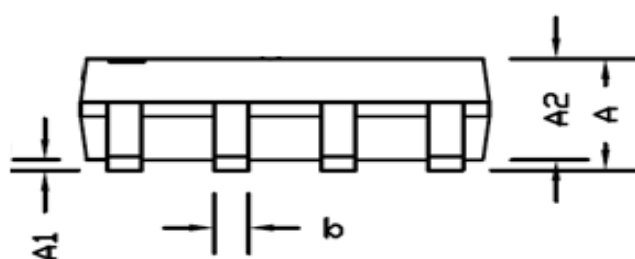
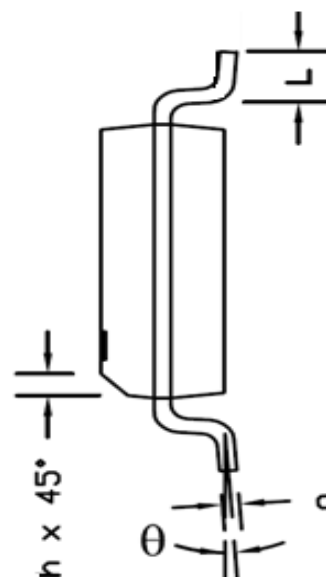
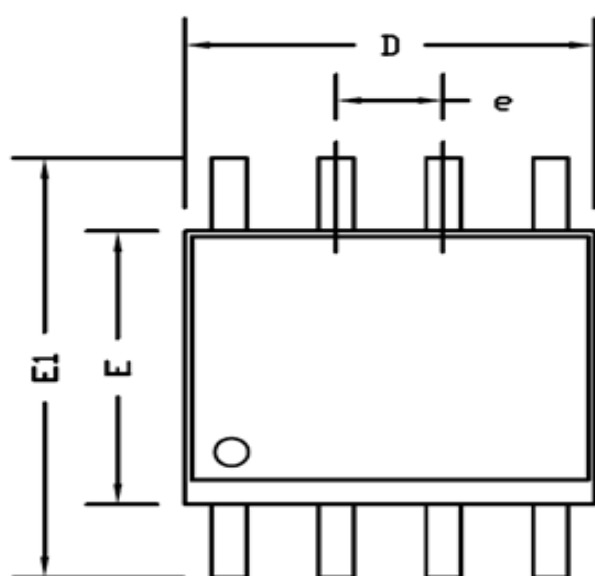
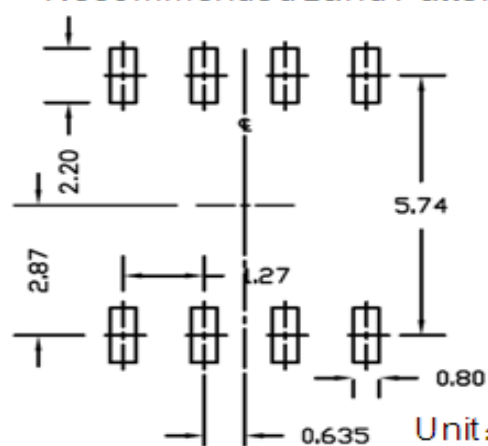

Fig 10: Max. Transient Thermal Impedance



Package Outline: SOP-8

Recommended Land Pattern

Unit: mm

Symbol	Dimensions In Millimeters		Dimensions In Inches	
	Min.	Max.	Min.	Max.
A	1.35	1.75	0.053	0.069
A1	0.10	0.25	0.004	0.010
A2	1.25	1.65	0.049	0.065
b	0.33	0.51	0.013	0.020
c	0.17	0.25	0.007	0.010
D	4.80	5.00	0.189	0.197
e	1.27 BSC.		0.050 BSC.	
E	3.80	4.00	0.150	0.157
E1	5.80	6.20	0.228	0.244
h	0.25	0.50	0.010	0.020
L	0.40	1.27	0.016	0.050
θ	0°	8°	0°	8°

Revision History

Revision	Date	Major changes
1.2	2022/12/20	Release of formal version

Disclaimer

Unless otherwise specified in the datasheet, the product is designed and qualified as a standard commercial product and is not intended for use in applications that require extraordinary levels of quality and reliability, such as automotive, aviation/aerospace and life-support devices or systems.

Any and all semiconductor products have certain probability to fail or malfunction, which may result in personal injury, death or property damage. Customer are solely responsible for providing adequate safe measures when design their systems.

This product is suitable for reflow soldering up to 260°C, not very suitable for wave soldering. The reliability of this product is not guaranteed under specific conditions when accepted by customers. CRM(CQ) reserves the right to improve product design, function and reliability without notice.

单击下面可查看定价，库存，交付和生命周期等信息

[>>CRMICRO\(华润微\)](#)