

## Features

- Uses CRM(CQ) advanced SkyMOS3 technology
- Extremely low on-resistance  $R_{DS(on)}$
- Excellent  $Q_g \times R_{DS(on)}$  product(FOM)
- Qualified according to JEDEC criteria

## Applications

- Motor control and drive
- Battery management System
- UPS (Uninterruptible Power Supplies)

## Product Summary

$V_{DS}$	100V
$R_{DS(on).typ}$	4.4mΩ
$I_D$	130A

**100% DVDS Tested**  
**100% Avalanche Tested**

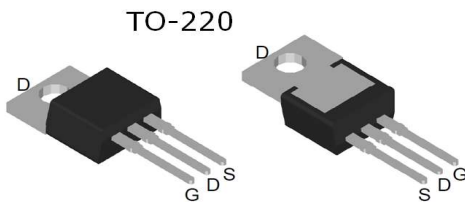

CRST052N10N3

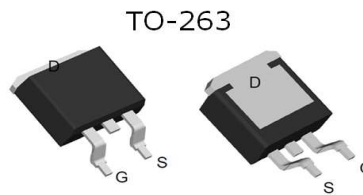

CRSS050N10N3

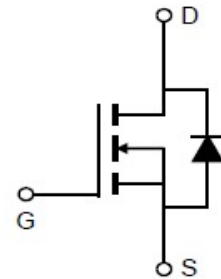

## Package Marking and Ordering Information

Part #	Marking	Package	Packing	Reel Size	Tape Width	Qty
CRST052N10N3	CRST052N10N3	TO-220	Tube	N/A	N/A	50pcs
CRSS050N10N3	CRSS050N10N3	TO-263	Tape	N/A	N/A	1000pcs

## Absolute Maximum Ratings

Parameter	Symbol	Value	Unit
Drain-source voltage	$V_{DS}$	100	V
Continuous drain current	$I_D$	130	A
$T_C = 25^\circ\text{C}$ (Silicon limit)		160	
$T_C = 25^\circ\text{C}$ (Package limit)		84	
$T_C = 100^\circ\text{C}$ (Silicon limit)			
Pulsed drain current ( $T_C = 25^\circ\text{C}$ , $t_p$ limited by $T_{jmax}$ )	$I_{D\ pulse}$	520	A
Avalanche energy, single pulse ( $I_D = 48\text{A}$ , $R_g = 25\Omega$ ) <sup>[1]</sup>	$E_{AS}$	583	mJ
Gate-Source voltage	$V_{GS}$	±20	V
Power dissipation ( $T_C = 25^\circ\text{C}$ )	$P_{tot}$	167	W
Operating junction and storage temperature	$T_j, T_{stg}$	-55...+150	°C
Soldering temperature, wave soldering only allowed at leads (1.6mm from case for 10s)	$T_{sold}$	260	°C

※. Notes:

1.EAS is tested at starting  $T_j = 25^\circ\text{C}$ ,  $L = 0.5\text{mH}$ ,  $I_{AS} = 48\text{A}$ ,  $V_{GS} = 10\text{V}$ .

**Thermal Resistance**

Parameter	Symbol	Max	Unit
Thermal resistance, junction – case.	$R_{thJC}$	0.75	°C/W
Thermal resistance, junction – ambient(min. footprint)	$R_{thJA}$	62	

**Electrical Characteristic (at  $T_j = 25\text{ }^\circ\text{C}$ , unless otherwise specified)**

Parameter	Symbol	Value			Unit	Test Condition
		min.	typ.	max.		

**Static Characteristic**

Drain-source breakdown voltage	$BV_{DSS}$	100	-	-	V	$V_{GS}=0V, I_D=250\mu A$
		100	-	-	V	$V_{GS}=0V, I_D=1mA$
Gate threshold voltage	$V_{GS(th)}$	2.3	3.3	4.3	V	$V_{DS}=V_{GS}, I_D=250\mu A$
Zero gate voltage drain current	$I_{DSS}$	-	-	1	$\mu A$	$V_{DS}=100V, V_{GS}=0V$ $T_j=25^\circ C$
		-	-	100		$T_j=125^\circ C$
Gate-source leakage current	$I_{GSS}$	0	-	$\pm 100$	nA	$V_{GS}=\pm 20V, V_{DS}=0V$
Drain-source on-state resistance	$R_{DS(on)}$	-	4.4	5.2	mΩ	$V_{GS}=10V, I_D=65A$ TO-220
		-	4.2	5.0		TO-263
Transconductance	$g_{fs}$	-	73.9	-	S	$V_{DS}=5V, I_D=65A$

**Dynamic Characteristic**

Input Capacitance	$C_{iss}$	-	4475	-	pF	$V_{GS}=0V, V_{DS}=50V,$ $f=1MHz$
Output Capacitance	$C_{oss}$	-	618	-		
Reverse Transfer Capacitance	$C_{rss}$	-	35	-		
Gate Total Charge	$Q_G$	-	82.8	-	nC	$V_{GS}=10V, V_{DS}=50V,$ $I_D=65A$
Gate-Source charge	$Q_{gs}$	-	31.7	-		
Gate-Drain charge	$Q_{gd}$	-	28.6	-		
Turn-on delay time	$t_{d(on)}$	-	19.4	-	ns	$V_{GS}=10V, V_{DD}=50V,$ $R_{G\_ext}=2.7\Omega$
Rise time	$t_r$	-	72.5	-		
Turn-off delay time	$t_{d(off)}$	-	41.5	-		
Fall time	$t_f$	-	24.4	-		
Gate resistance	$R_G$	-	2.3	-	Ω	$V_{GS}=0V, V_{DS}=0V,$ $f=1MHz$

**Body Diode Characteristic**

Parameter	Symbol	Value			Unit	Test Condition
		min.	typ.	max.		
Body Diode Forward Voltage	$V_{SD}$	-	0.95	1.4	V	$V_{GS}=0V, I_{SD}=65A$
Body Diode Reverse Recovery Time	$t_{rr}$	-	56.9	-	ns	$I_F=65A,$ $dI/dt=100A/\mu s$
Body Diode Reverse Recovery Charge	$Q_{rr}$	-	110.3	-	nC	

## Typical Performance Characteristics

Fig 1: Output Characteristics

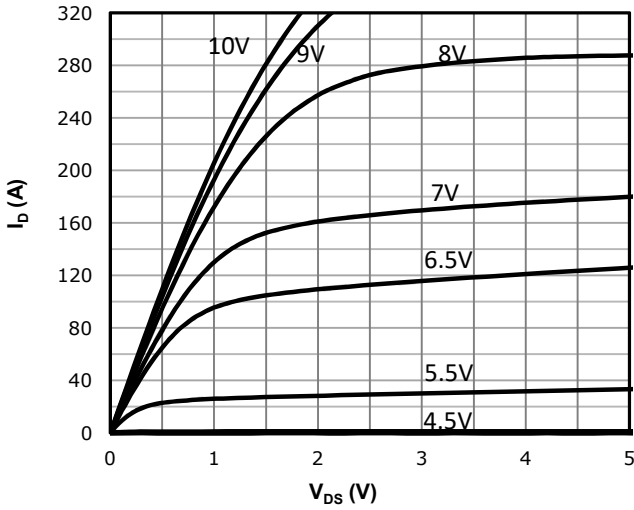

Fig 2: Transfer Characteristics

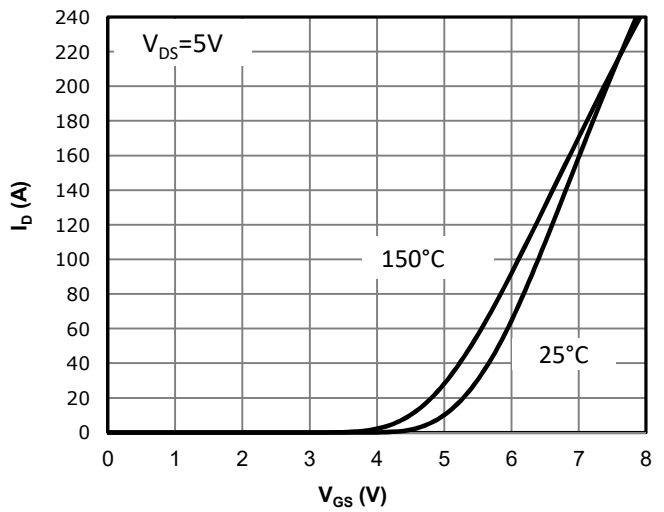
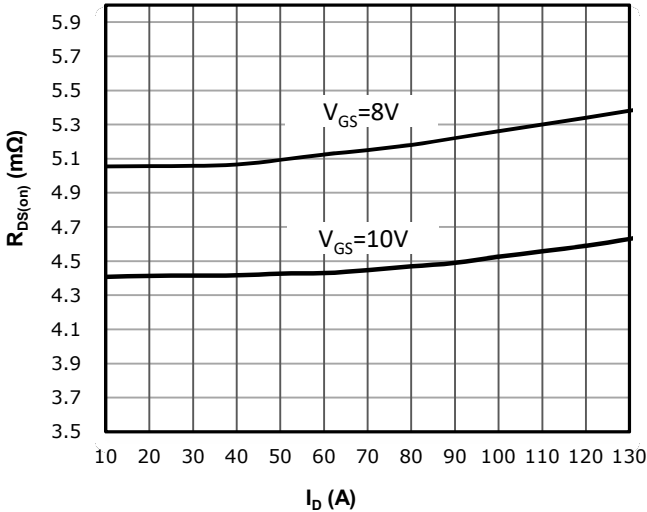
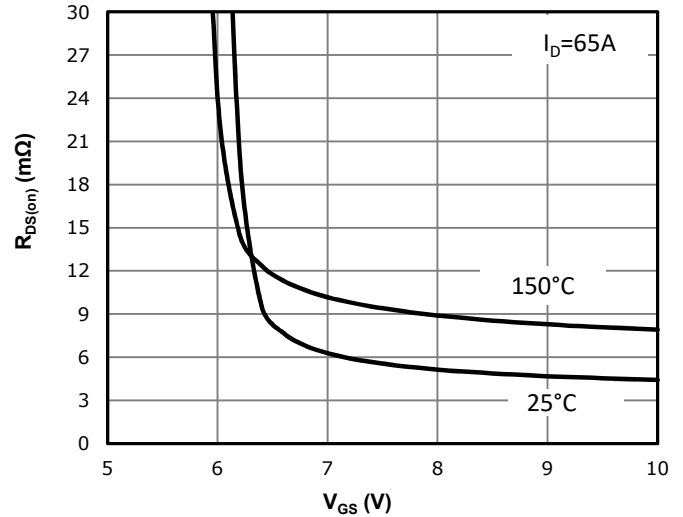
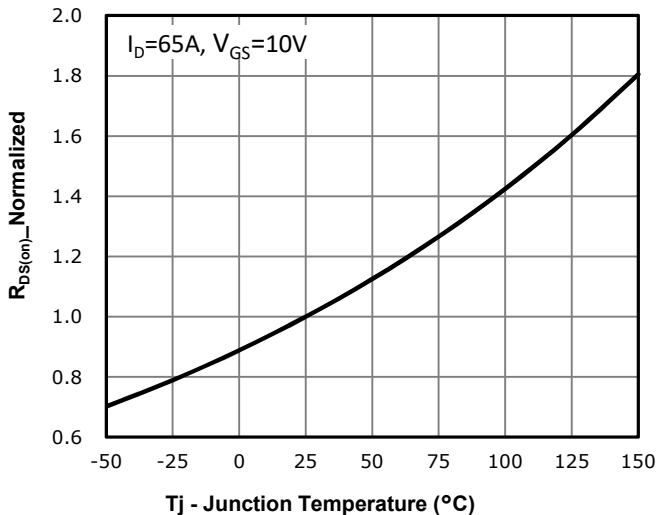
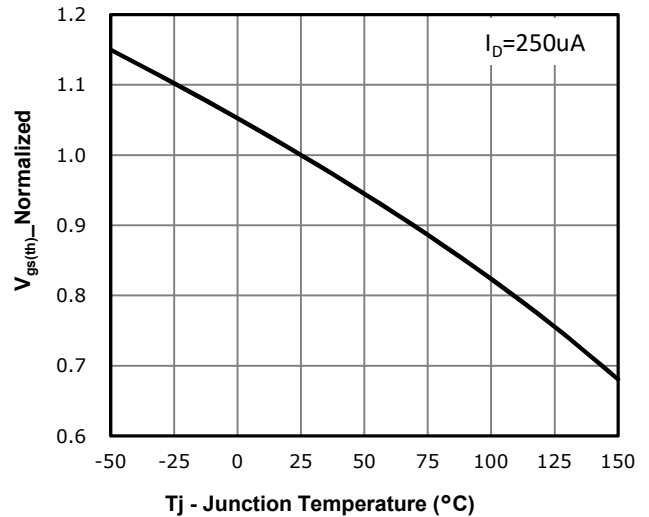

 Fig 3:  $R_{DS(on)}$  vs Drain Current and Gate Voltage

 Fig 4:  $R_{DS(on)}$  vs Gate Voltage

 Fig 5:  $R_{DS(on)}$  vs. Temperature

 Fig 6:  $V_{GS(th)}$  vs. Temperature

Fig 7: BVdss vs. Temperature

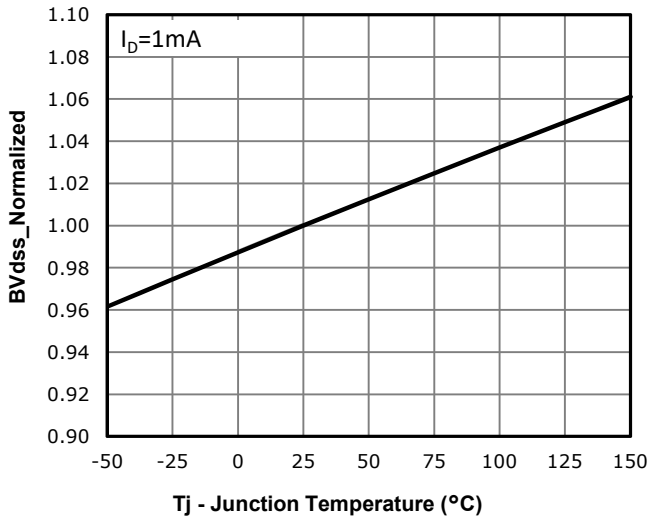

Fig 8: Capacitance Characteristics

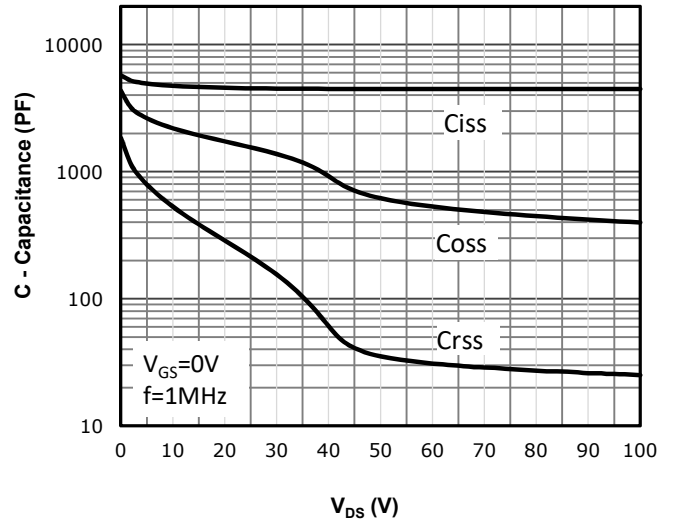

Fig 9: Gate Charge Characteristics

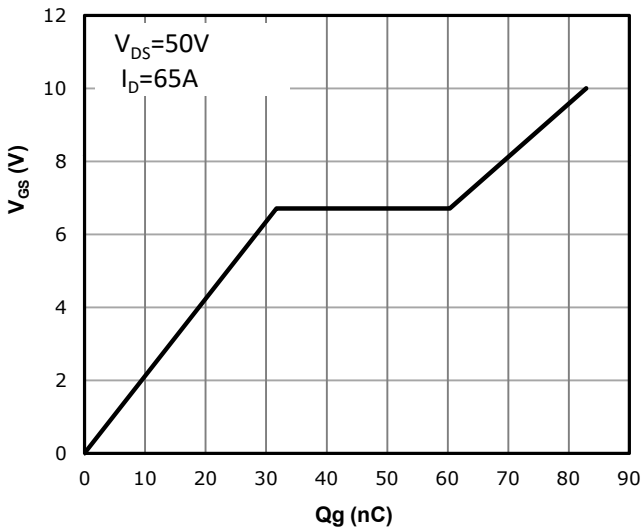

Fig 10: Body-diode Forward Characteristics

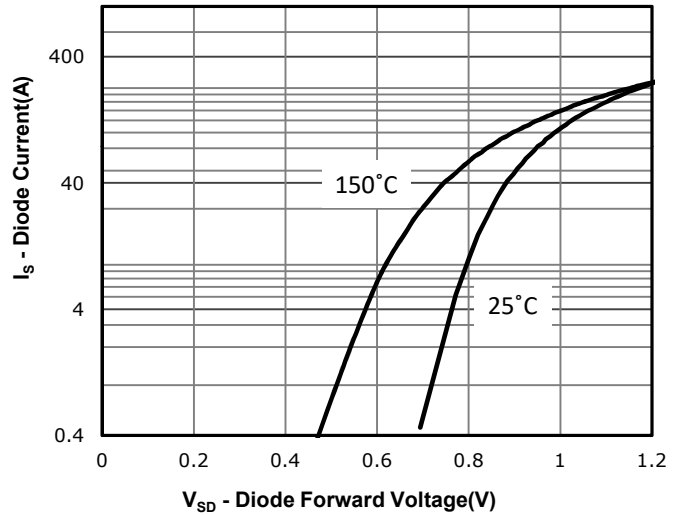

Fig 11: Power Dissipation

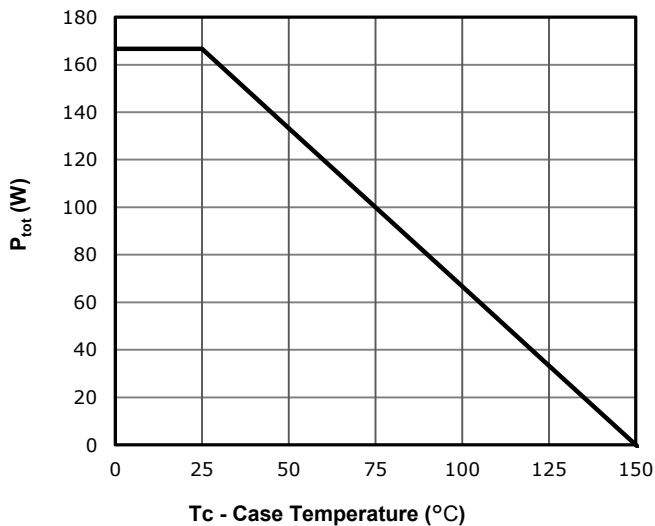

Fig 12: Drain Current Derating

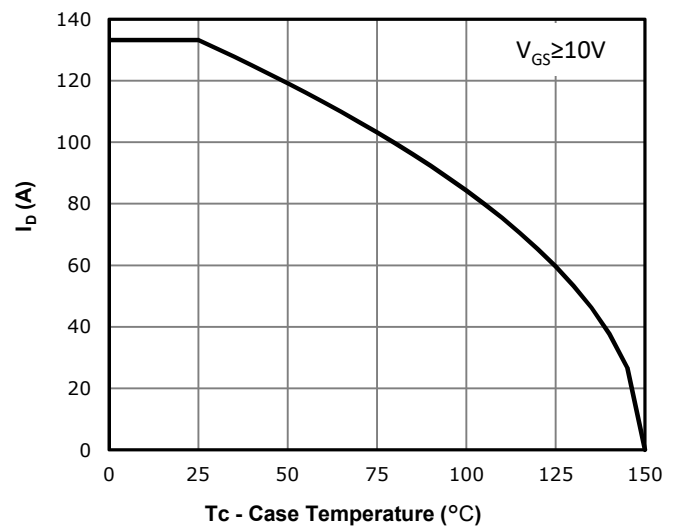

Fig 13: Safe Operating Area

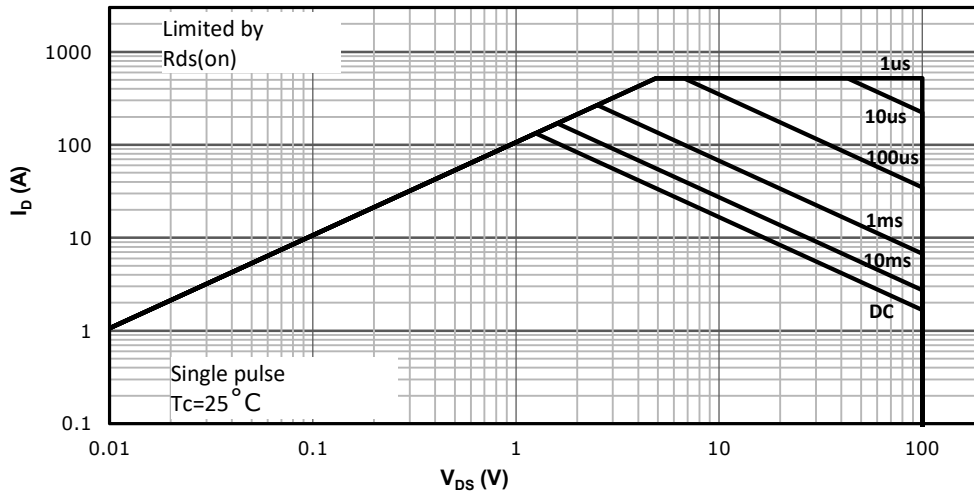
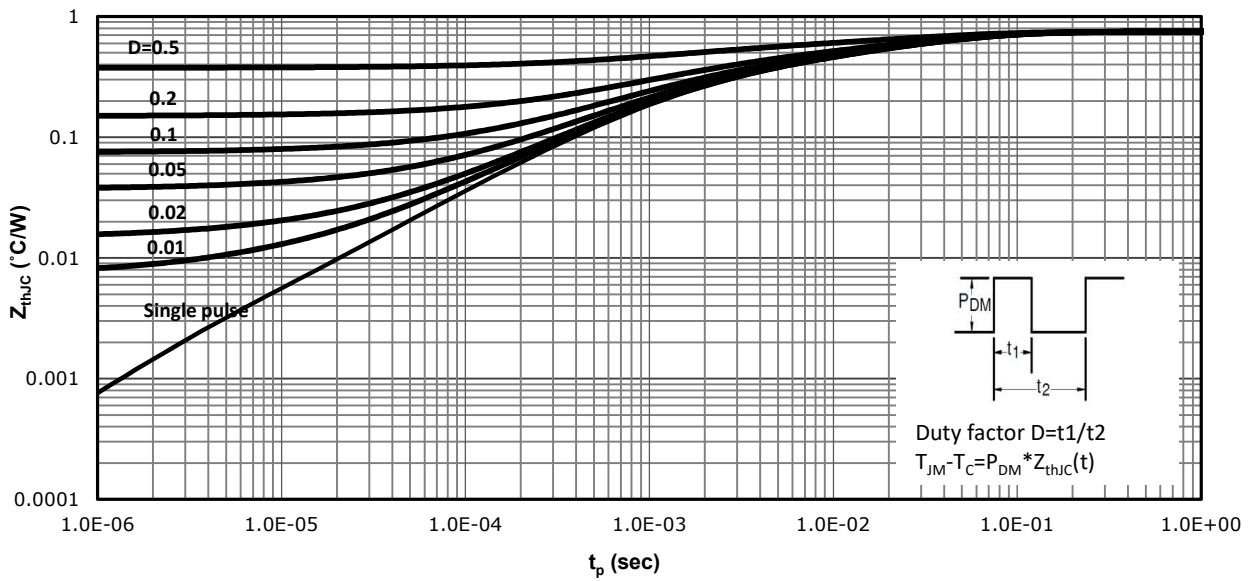
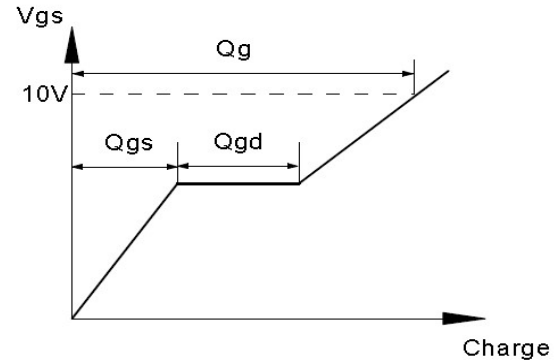
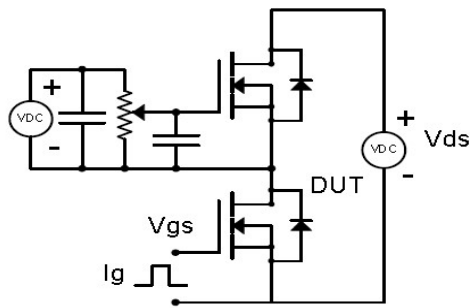

Fig 14: Max. Transient Thermal Impedance



**Test Circuit & Waveform**

Gate Charge Test Circuit &amp; Waveform



Resistive Switching Test Circuit &amp; Waveforms

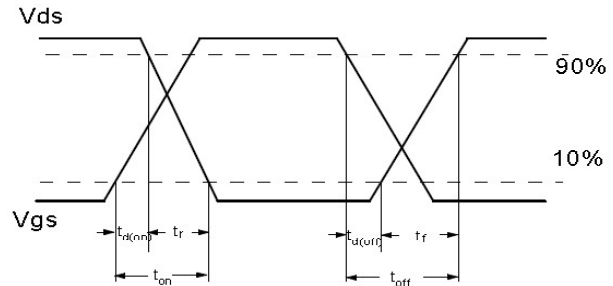
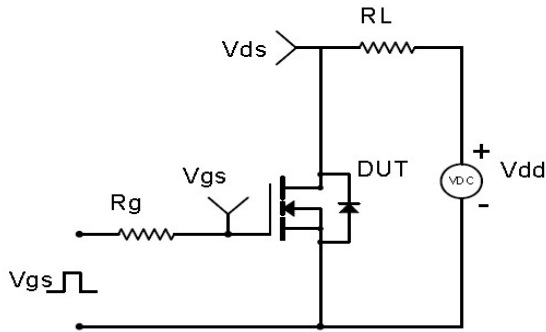

Unclamped Inductive Switching (UIS) Test Circuit &amp; Waveforms

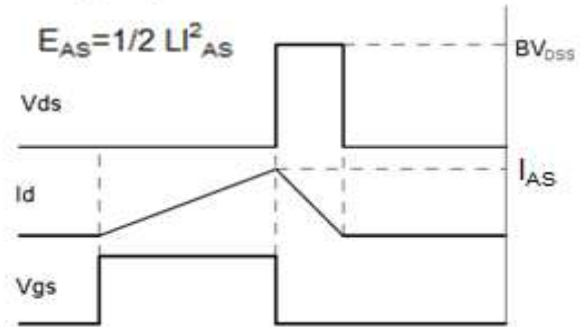
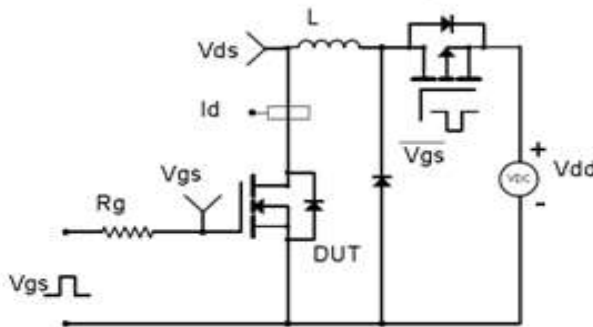

Diode Recovery Test Circuit &amp; Waveforms

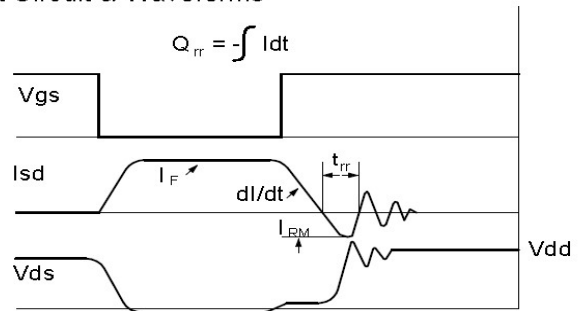
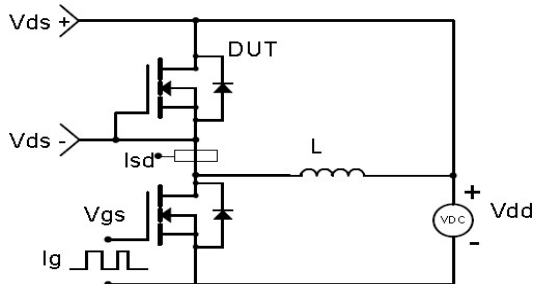

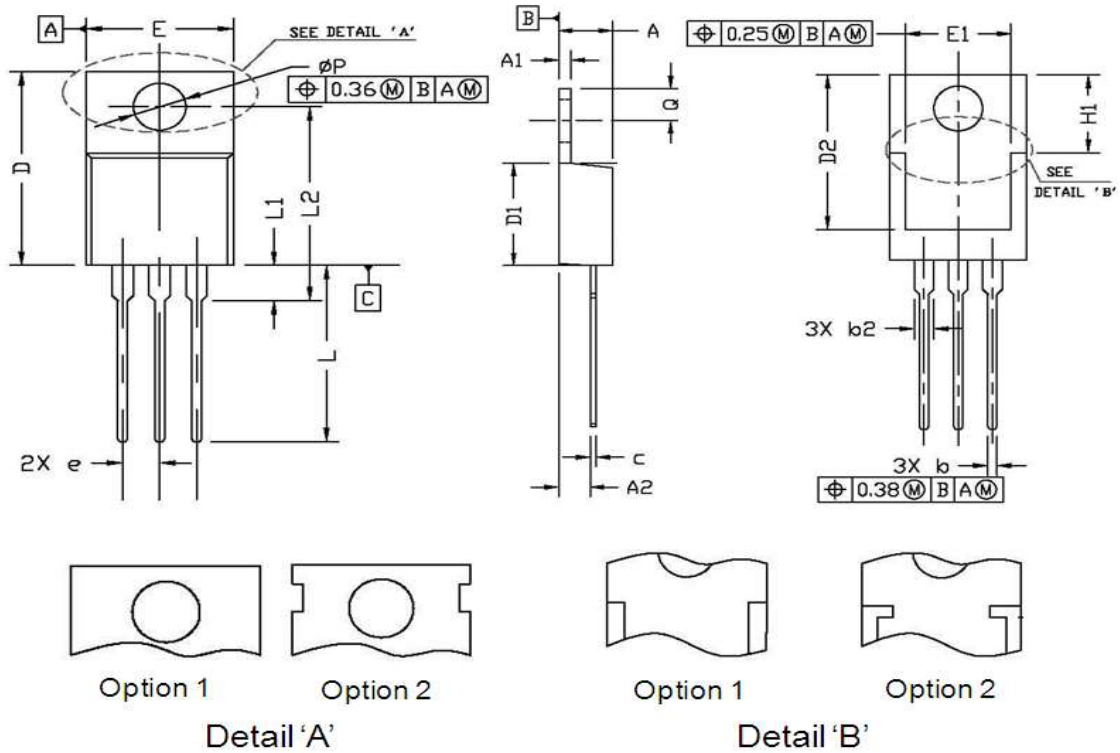
**Package Outline: TO-220-3L**

Symbol	Dimensions In Millimeters		Dimensions In Inches	
	Min.	Max.	Min.	Max.
A	4.30	4.80	0.169	0.189
A1	1.20	1.45	0.047	0.057
A2	2.20	2.90	0.087	0.114
b	0.69	0.95	0.027	0.037
b2	1.00	1.60	0.039	0.063
c	0.33	0.65	0.013	0.026
D	14.70	16.20	0.579	0.638
D1	8.59	9.65	0.338	0.380
D2	11.75	13.60	0.463	0.535
e	2.54 BSC.		0.100 BSC.	
E	9.60	10.60	0.378	0.417
E1	7.00	8.89	0.276	0.350
H1	6.20	7.00	0.244	0.276
L	12.60	14.80	0.496	0.583
L1	2.70	3.80	0.106	0.150
L2	12.13	16.50	0.478	0.650
Q	2.40	3.10	0.094	0.122
P	3.50	3.95	0.138	0.156

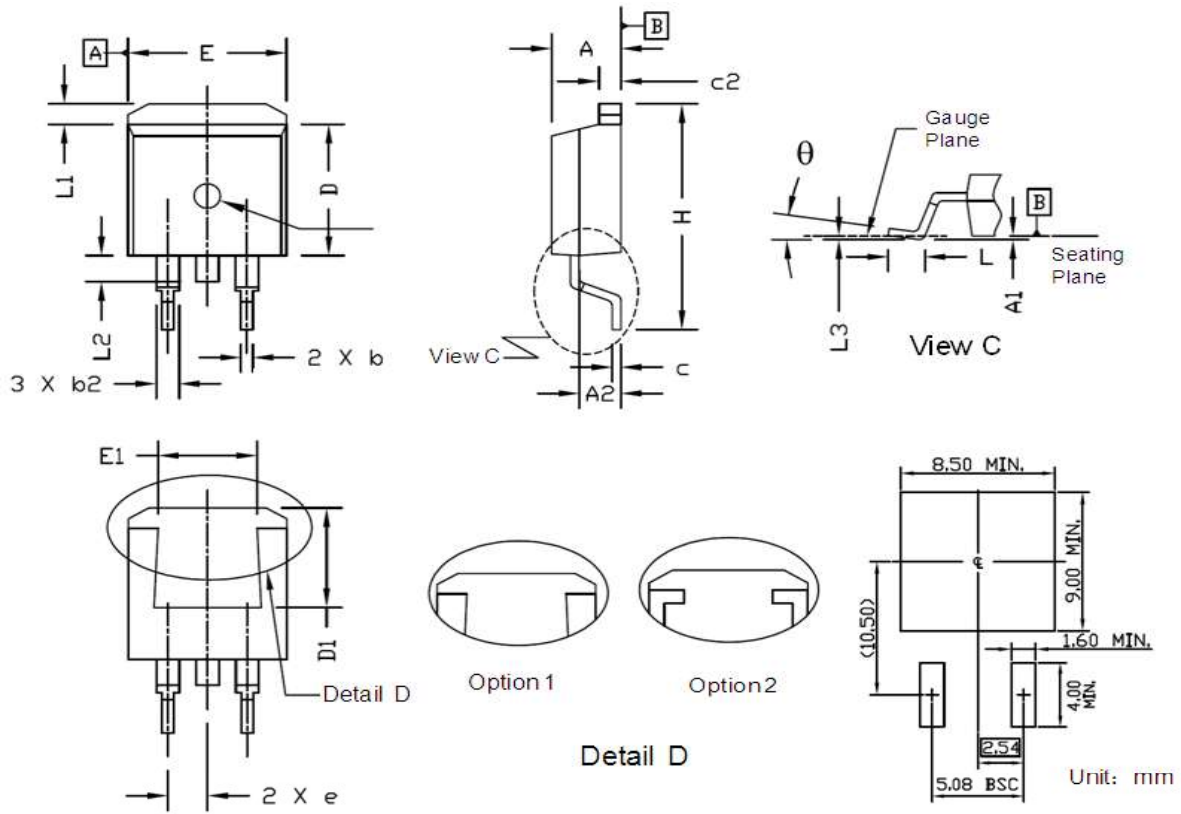

**Package Outline: TO-263**

Symbol	Dimensions In Millimeters		Dimensions In Inches		
	Min.	Max.	Min.	Max.	
A	4.30	4.86	0.169	0.191	
A1	0.00	0.25	0.000	0.010	
A2	2.20	2.90	0.087	0.114	
b	0.68	0.94	0.027	0.037	
b2	1.14	1.78	0.045	0.070	
c	0.33	0.65	0.013	0.026	
c2	1.17	1.40	0.046	0.055	
D	8.38	9.45	0.330	0.372	
D1	6.90	8.17	0.272	0.322	
e	2.54 BSC.		0.100 BSC.		
E	9.78	10.50	0.385	0.413	
E1	6.50	8.60	0.256	0.339	
H	14.61	15.88	0.575	0.625	
L	1.78	2.79	0.070	0.110	
L1	0.70	1.60	0.028	0.063	
L2	1.00	1.78	0.039	0.070	
L3	0.25 BSC.		0.010 BSC.		
θ	Option A	-8°	0°	-8°	0°
	Option B	0°	8°	0°	8°

## Marking

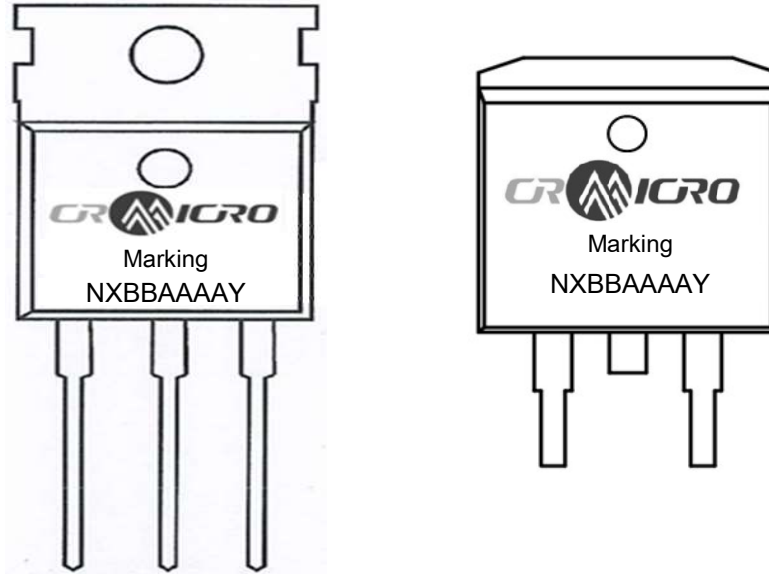

**NOTE:**

**NXBBAAAAY**

- N —Wire Bond code
- X —Assembly location code
- BB —Fab code
- AAAA —Lot code
- Y —Bin code

## Revision History

Revision	Date	Major changes
1.0	2023/9/5	Release of Preliminary version.

## Disclaimer

Unless otherwise specified in the datasheet, the product is designed and qualified as a standard commercial product and is not intended for use in applications that require extraordinary levels of quality and reliability, such as automotive, aviation/aerospace and life-support devices or systems.

Any and all semiconductor products have certain probability to fail or malfunction, which may result in personal injury, death or property damage. Customer are solely responsible for providing adequate safe measures when design their systems.

CRM(CQ) reserves the right to improve product design, function and reliability without notice.

单击下面可查看定价，库存，交付和生命周期等信息

[>>CRMICRO\(华润微\)](#)