

Features

- Uses CRM(CQ) advanced Trench technology
- Extremely low on-resistance $R_{DS(on)}$
- Excellent $Q_g \times R_{DS(on)}$ product(FOM)
- Qualified according to JEDEC criteria

Applications

- Motor control and drive
- Battery management
- UPS (Uninterruptible Power Supplies)

Product Summary

V_{DS}	60V
$R_{DS(on)}$ typ.	3.3mΩ
I_D	120A

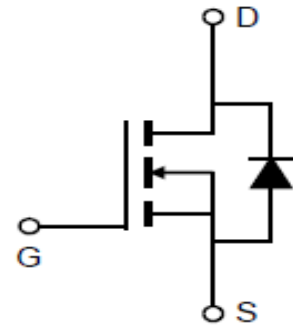
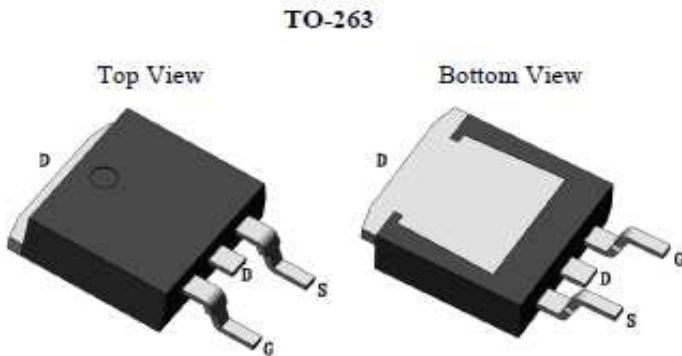
100% DVDS Tested
100% Avalanche Tested

Package Marking and Ordering Information

Part #	Marking	Package	Packing	Reel Size	Tape Width	Qty
CRTS045N06N	CRTS045N06N	TO-263	Reel	N/A	N/A	1000pcs

Absolute Maximum Ratings

Parameter	Symbol	Value	Unit
Drain-source voltage	V_{DS}	60	V
Continuous drain current $T_C = 25^\circ\text{C}$ (Silicon limit) $T_C = 25^\circ\text{C}$ (Package limit) $T_C = 100^\circ\text{C}$ (Silicon limit)	I_D	158 120 100	A
Pulsed drain current ($T_C = 25^\circ\text{C}$, t_p limited by T_{jmax})	$I_{D\ pulse}$	480	A
Avalanche energy, single pulse ($L=0.5\text{mH}$, $R_g=50\Omega$)	E_{AS}	361	mJ
Gate-Source voltage	V_{GS}	± 25	V
Power dissipation ($T_C = 25^\circ\text{C}$)	P_{tot}	184	W
Operating junction and storage temperature	T_j, T_{stg}	-55...+150	$^\circ\text{C}$
Soldering temperature, wave soldering only allowed at leads (1.6mm from case for 10s)	T_{sold}	260	$^\circ\text{C}$

Thermal Resistance

Parameter	Symbol	Max	Unit
Thermal resistance, junction – case.	R_{thJC}	0.68	°C/W
Thermal resistance, junction – ambient(min. footprint)	R_{thJA}^*	91	

Electrical Characteristic (at $T_j = 25\text{ }^\circ\text{C}$, unless otherwise specified)

Parameter	Symbol	Value			Unit	Test Condition
		min.	typ.	max.		

Static Characteristic

Drain-source breakdown voltage	BV_{DSS}	60	-	-	V	$V_{GS}=0V, I_D=250\mu A$
Gate threshold voltage	$V_{GS(th)}$	2.4	3	3.6	V	$V_{DS}=V_{GS}, I_D=250\mu A$
Zero gate voltage drain current	I_{DSS}	-	0.05	1	μA	$V_{DS}=60V, V_{GS}=0V$ $T_j=25^\circ C$ $T_j=150^\circ C$
Gate-source leakage current	I_{GSS}	-	± 10	± 100	nA	$V_{GS}=\pm 25V, V_{DS}=0V$
Drain-source on-state resistance	$R_{DS(on)}$	-	3.3	4.5	mΩ	$V_{GS}=10V, I_D=60A,$ $T_j=25^\circ C$ $T_j=150^\circ C$
Transconductance	g_{fs}	-	150	-	S	$V_{DS}=5V, I_D=60A$

Dynamic Characteristic

Input Capacitance	C_{iss}	-	4531	-	pF	$V_{GS}=0V, V_{DS}=30V,$ $f=1MHz$
Output Capacitance	C_{oss}	-	704	-		
Reverse Transfer Capacitance	C_{rss}	-	453	-		
Gate Total Charge	Q_G	-	110	-	nC	$V_{GS}=10V, V_{DS}=30V,$ $I_D=60A, f=1MHz$
Gate-Source charge	Q_{gs}	-	24	-		
Gate-Drain charge	Q_{gd}	-	45	-		
Turn-on delay time	$t_{d(on)}$	-	18	-	ns	$V_{GS}=10V, V_{DD}=30V,$ $R_{G_ext}=2.7\Omega, I_D=60A$
Rise time	t_r	-	97	-		
Turn-off delay time	$t_{d(off)}$	-	51	-		
Fall time	t_f	-	102	-		
Gate resistance	R_G	-	0.8	-	Ω	$V_{GS}=0V, V_{DS}=0V,$ $f=1MHz$

Body Diode Characteristic

Parameter	Symbol	Value			Unit	Test Condition
		min.	typ.	max.		
Body Diode Forward Voltage	V_{SD}	-	0.9	1.3	V	$V_{GS}=0V, I_{SD}=60A$
Body Diode Continuous Forward Current	I_S			120	A	$T_C = 25^{\circ}C$
Body Diode Reverse Recovery Time	t_{rr}	-	42	-	ns	$I_F=60A, dI/dt=100A/\mu s$
Body Diode Reverse Recovery Charge	Q_{rr}	-	56	-	nC	

*The value of R_{thJA} is measured by placing the device in a still air box which is one cubic foot.

Typical Performance Characteristics

Fig 1: Output Characteristics

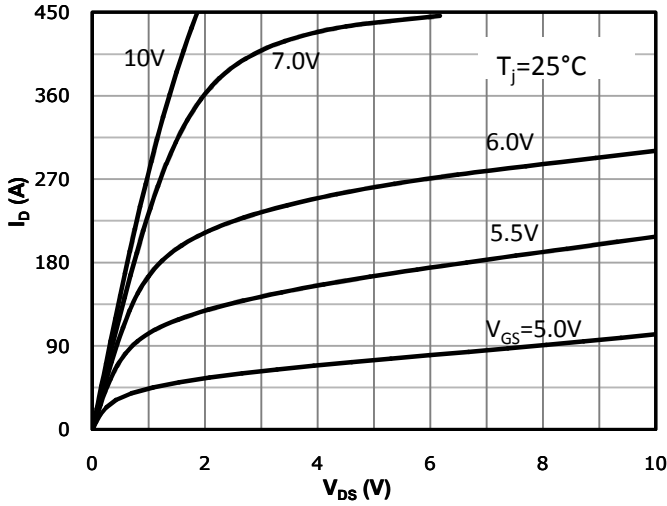

Fig 2: Transfer Characteristics

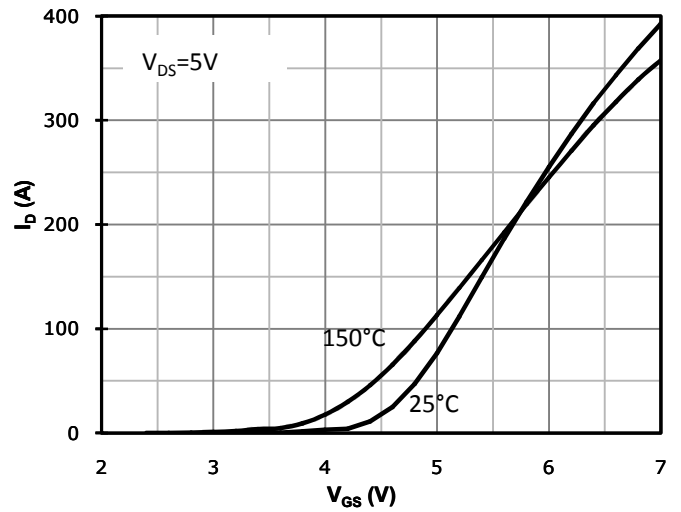

Fig 3: $R_{DS(on)}$ vs Drain Current and Gate Voltage

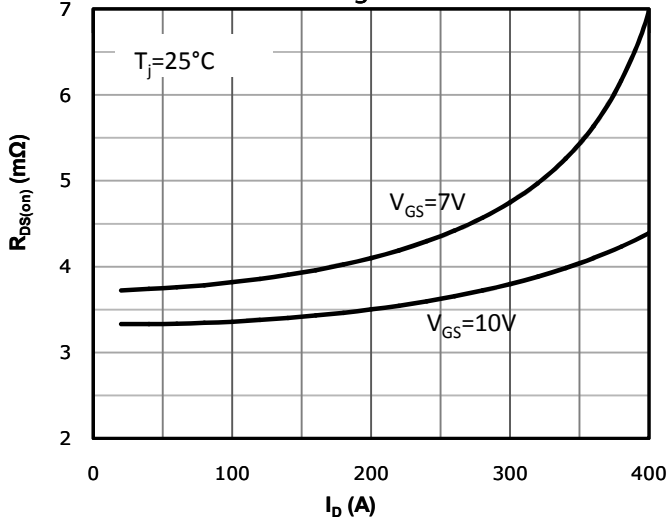

Fig 4: $R_{DS(on)}$ vs Gate Voltage

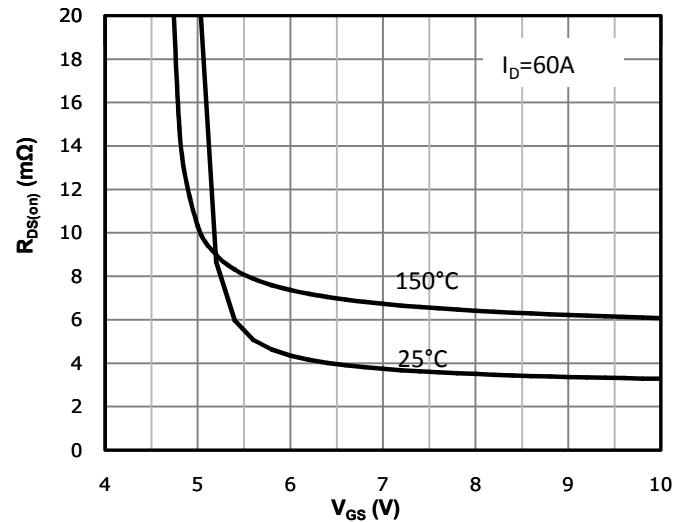

Fig 5: $R_{DS(on)}$ vs. Temperature

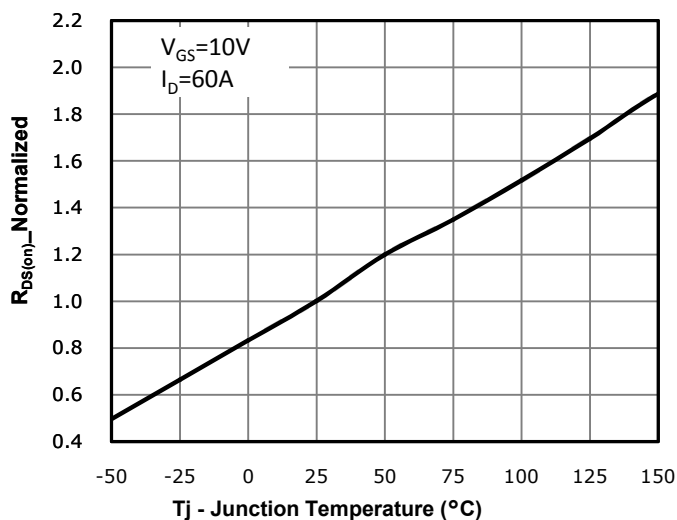

Fig 6: Capacitance Characteristics

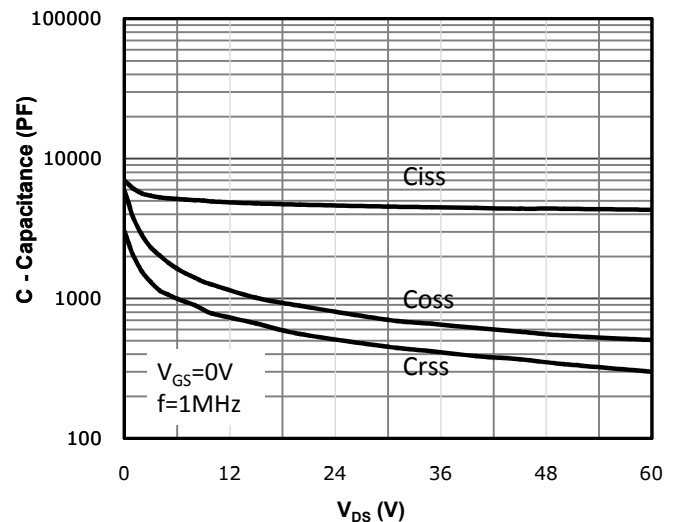

Fig 7: Gate Charge Characteristics

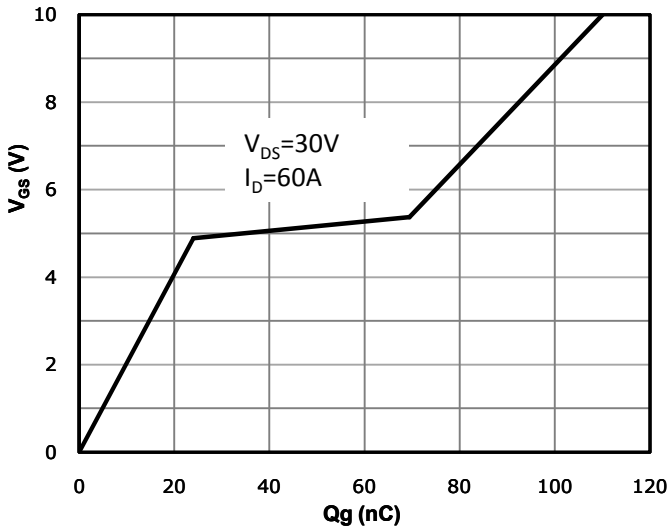

Fig 8: Body-diode Forward Characteristics

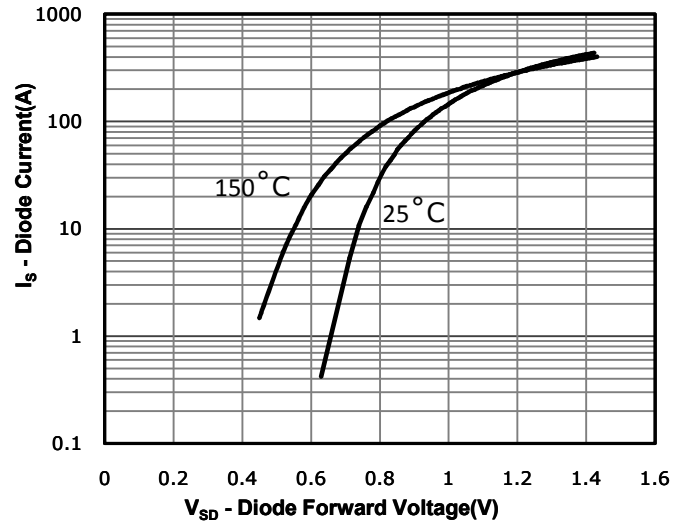

Fig 9: Power Dissipation

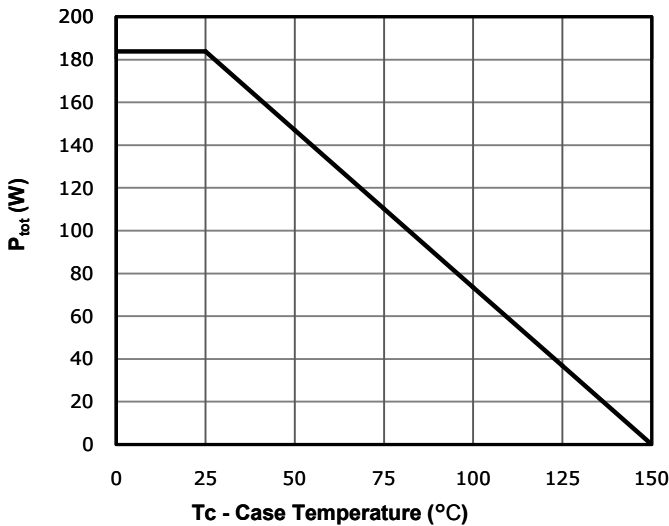

Fig 10: Drain Current Derating

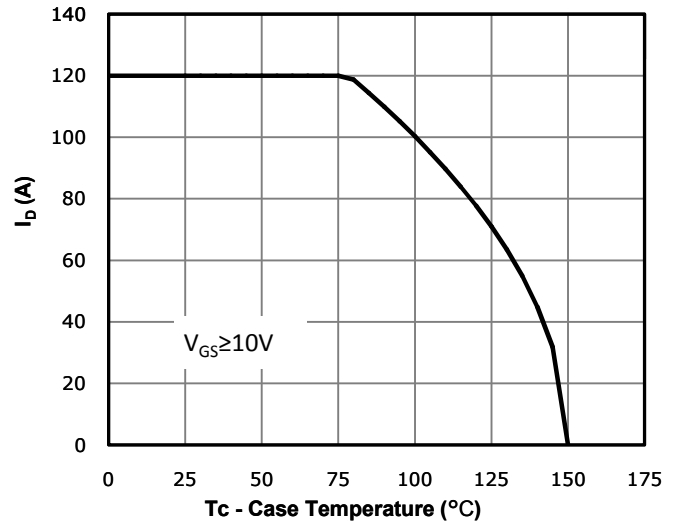

Fig 11: Safe Operating Area

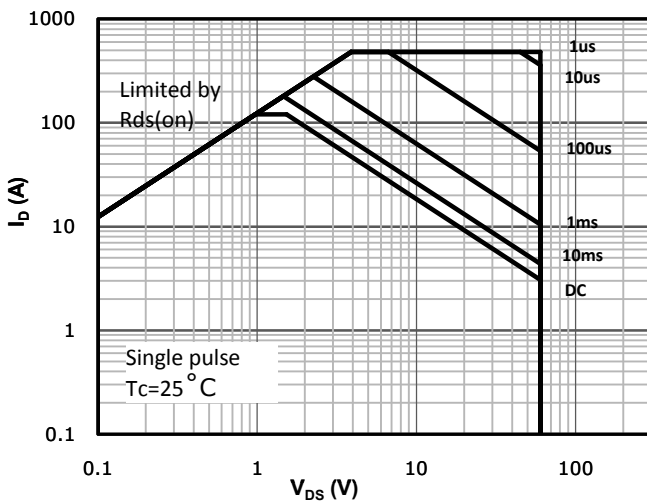
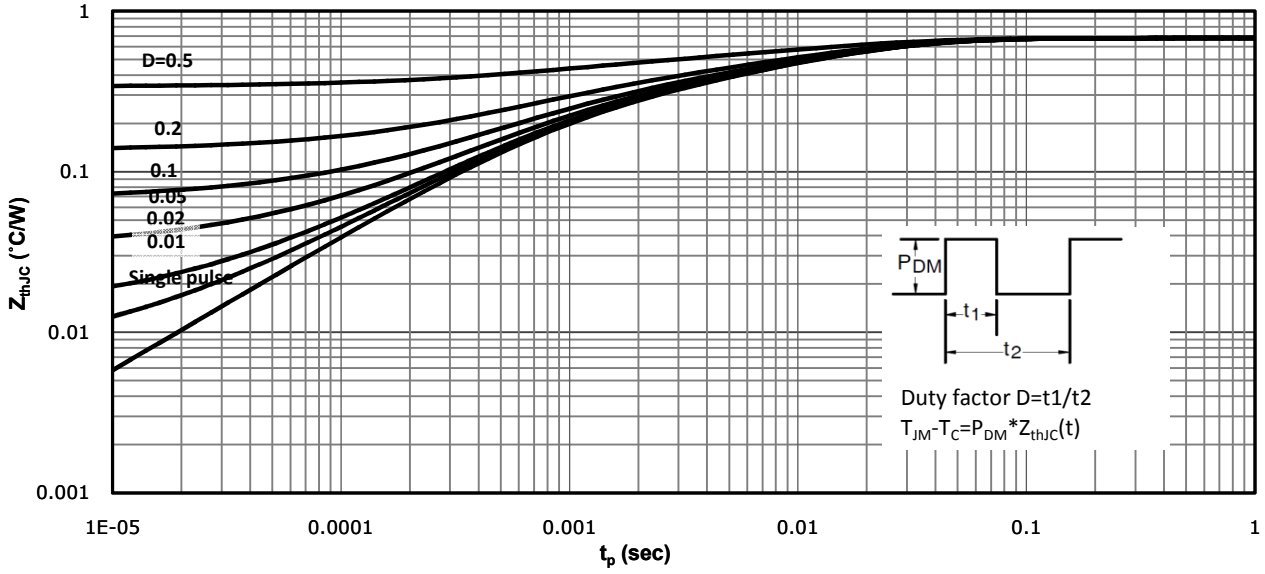
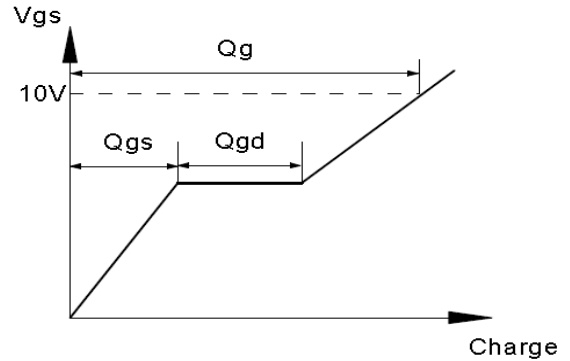

Fig 12: Max. Transient Thermal Impedance



Test Circuit & Waveform

Gate Charge Test Circuit & Waveform



Resistive Switching Test Circuit & Waveforms

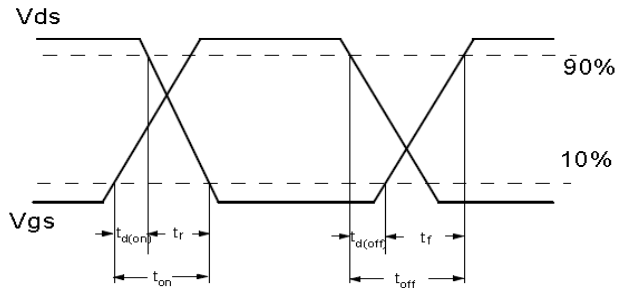
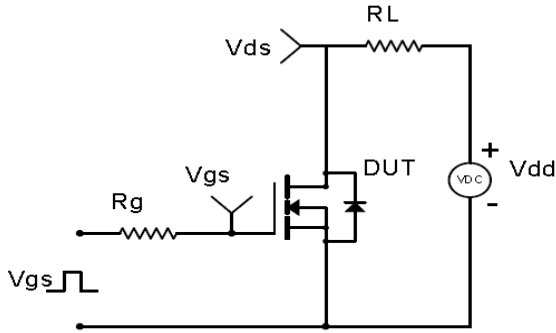

Unclamped Inductive Switching (UIS) Test Circuit & Waveforms

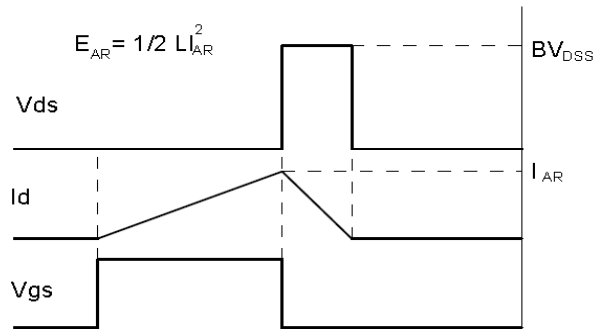
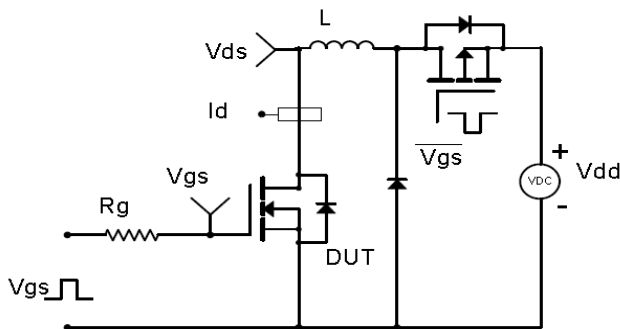

Diode Recovery Test Circuit & Waveforms

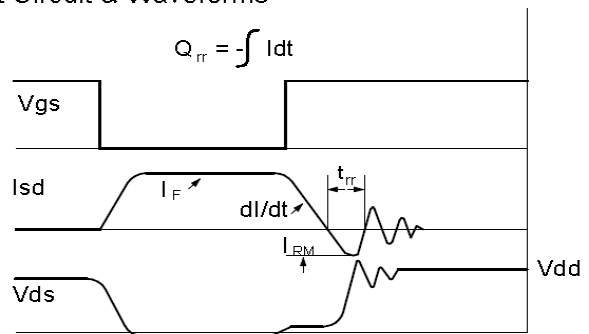
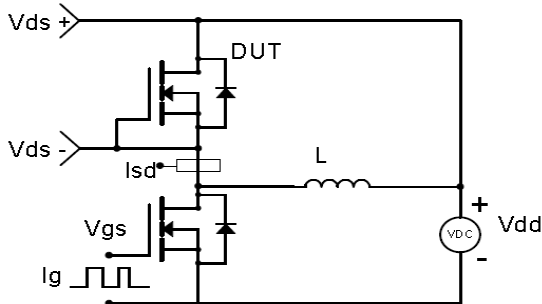

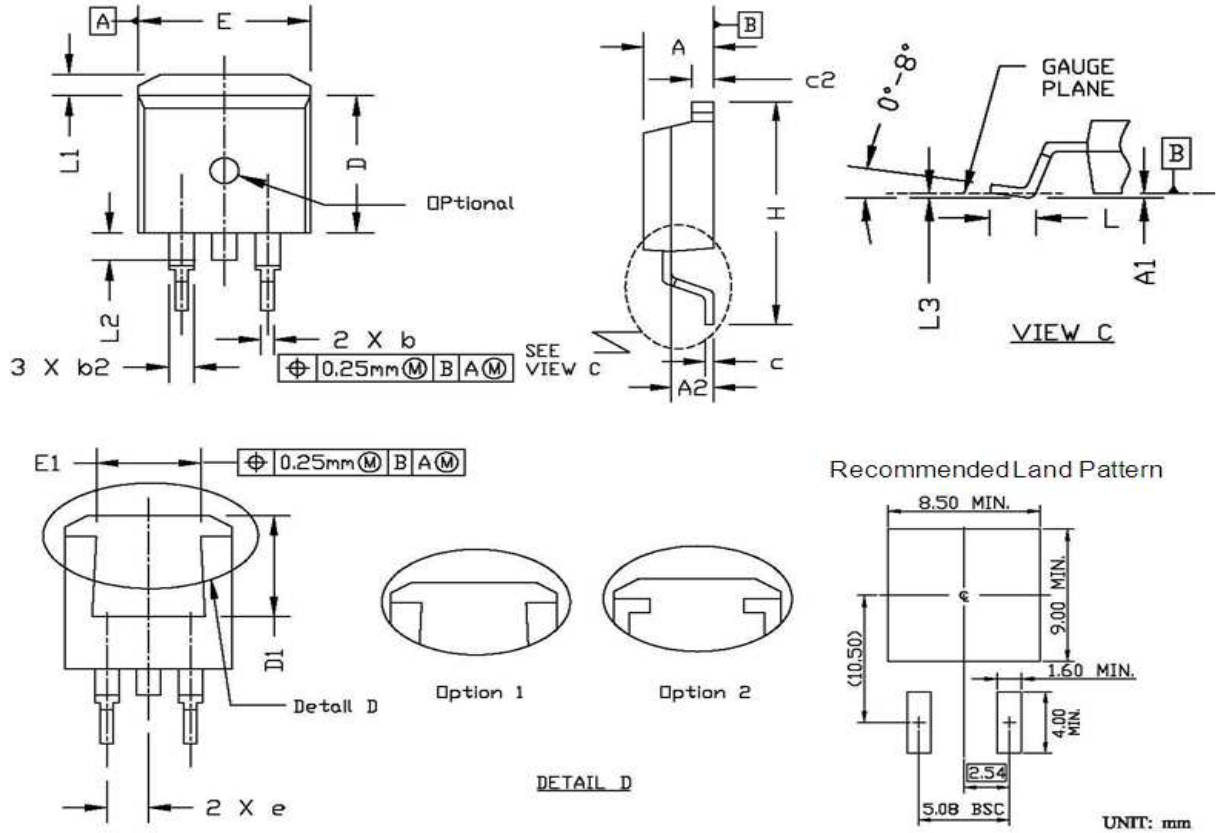
Package Outline: TO-263

Symbol	Dimensions In Millimeters		Dimensions In Inches	
	Min.	Max.	Min.	Max.
A	4.30	4.86	0.169	0.191
A1	0.00	0.25	0.000	0.010
A2	2.34	2.79	0.092	0.110
b	0.68	0.94	0.027	0.037
b2	1.15	1.35	0.045	0.053
c	0.33	0.65	0.013	0.026
c2	1.17	1.40	0.046	0.055
D	8.38	9.45	0.330	0.372
D1	6.90	8.17	0.272	0.322
e	2.54 BSC.		0.100 BSC.	
E	9.78	10.50	0.385	0.413
E1	6.50	8.60	0.256	0.339
H	14.61	15.88	0.575	0.625
L	2.24	3.00	0.088	0.118
L1	0.70	1.60	0.028	0.063
L2	1.00	1.78	0.039	0.070
L3	0.00	0.25	0.000	0.010

Revision History

Revision	Date	Major changes
1.0	2018/12/10	Release of formal version
2.0	2019/7/22	Increase the environmental labeling, I_S , T_{soldr} , I_{GSS} test value at $V_{GS}=-25V$; Update $R_{DS(on)}$, $Q_G/Q_{gs}/Q_{gd}$, g_{fs} , V_{SD} , $t_{d(on)}/t_r/t_{d(off)}/t_f$ and t_{rr}/Q_{rr} test current from 40A to 60A; Update Fig3/Fig4 of Typical Performance Characteristics; Update Package Outline.

Disclaimer

Unless otherwise specified in the datasheet, the product is designed and qualified as a standard commercial product and is not intended for use in applications that require extraordinary levels of quality and reliability, such as automotive, aviation/aerospace and life-support devices or systems.

Any and all semiconductor products have certain probability to fail or malfunction, which may result in personal injury, death or property damage. Customer are solely responsible for providing adequate safe measures when design their systems.

CRM(CQ) reserves the right to improve product design, function and reliability without notice.

单击下面可查看定价，库存，交付和生命周期等信息

[>>CRMICRO\(华润微\)](#)