

Features

- Uses CRM(CQ) advanced SkyMOS3 technology
- Extremely low on-resistance $R_{DS(on)}$
- Excellent $Q_g \times R_{DS(on)}$ product(FOM)
- Qualified according to JEDEC criteria

Applications

- Synchronous Rectification for AC/DC Quick Charger
- Battery management
- UPS (Uninterruptible Power Supplies)

Product Summary

V_{DS}	150V
$R_{DS(on)@10V \text{ typ}}$	8.8mΩ
I_D	75A

100% Avalanche Tested
100% DVDS Tested

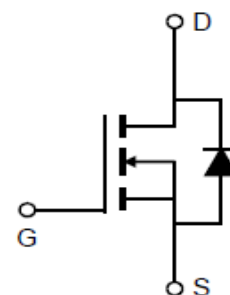
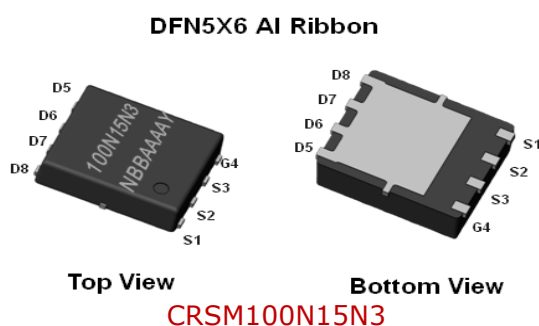
Package Marking and Ordering Information

Part #	Marking	Package	Packing	Reel Size	Tape Width	Qty
CRSM100N15N3	100N15N3	DFN5*6 Rib	Tape&Reel	N/A	N/A	5000pcs

Absolute Maximum Ratings

Parameter	Symbol	Value	Unit
Drain-source voltage	V_{DS}	150	V
Continuous drain current $T_C = 25^\circ\text{C}$ (Silicon limit) $T_C = 100^\circ\text{C}$ (Silicon limit)	I_D	75 54	A
Pulsed drain current ($T_C = 25^\circ\text{C}$, t_p limited by T_{jmax})	$I_{D \text{ pulse}}$	300	A
Avalanche energy, single pulse ($I_{as}=30\text{A}$, $R_g=25\Omega$)	E_{AS}	225	mJ
Gate-Source voltage	V_{GS}	± 20	V
Power dissipation ($T_C = 25^\circ\text{C}$)	P_{tot}	128	W
Operating junction and storage temperature	T_j, T_{stg}	-55...+150	$^\circ\text{C}$
Soldering temperature, wave soldering only allowed at leads (1.6mm from case for 10s)	T_{sold}	260	$^\circ\text{C}$

Thermal Resistance

Parameter	Symbol	Value			Unit	Test Condition
		min.	typ.	max.		
Thermal resistance, junction – case.	RthJC	-	0.75	1.0	°C/W	-
Thermal resistance, junction - ambient(min. footprint)	RthJA	-	-	60.5	°C/W	-

Electrical Characteristic (at Tj = 25 °C, unless otherwise specified)

Parameter	Symbol	Value			Unit	Test Condition
		min.	typ.	max.		

Static Characteristic

Drain-source breakdown voltage	BV_{DSS}	150	-	-	V	$V_{GS}=0V, I_D=250\mu A$
Gate threshold voltage	$V_{GS(th)}$	2.0	3.0	4.0	V	$V_{DS}=V_{GS}, I_D=250\mu A$
Zero gate voltage drain current	I_{DSS}	-	0.1	1	μA	$V_{DS}=120V, V_{GS}=0V$ $T_j=25^\circ C$
		-	10	100		$T_j=125^\circ C$
Gate-source leakage current	I_{GSS}	-	-	100	nA	$V_{GS}=\pm 20V, V_{DS}=0V$
Drain-source on-state resistance	$R_{DS(on)}$	-	8.8	10.0	mΩ	$V_{GS}=10V, I_D=40A$
		-	9.8	11.3		$V_{GS}=8V, I_D=20A$
Transconductance	g_{fs}	-	55	-	S	$V_{DS}=5V, I_D=40A$

Dynamic Characteristic

Input Capacitance	C_{iss}	1470.7	2206	3309	pF	$V_{GS}=0V, V_{DS}=75V,$ $f=1MHz$
Output Capacitance	C_{oss}	254.2	381.3	571.95		
Reverse Transfer Capacitance	C_{rss}	20	30	60		
Gate Total Charge	Q_G	22.7	34	51.0	nC	$V_{GS}=10V, V_{DS}=75V,$ $I_D=40A, f=1MHz$
Gate-Source charge	Q_{gs}	9.9	14.9	22.4		
Gate-Drain charge	Q_{gd}	4.8	7.2	10.8		
Turn-on delay time	$t_{d(on)}$	7.3	14.6	29.2	ns	$V_{GS}=10V,$ $V_{DD}=75V,$ $I_D=44A, R_{G_ext}=2.7\Omega$
Rise time	t_r	40.3	80.6	161.2		
Turn-off delay time	$t_{d(off)}$	11.15	22.3	44.6		
Fall time	t_f	29.35	58.7	117.4		

Gate resistance	R_G	1	1.45	2.2	Ω	$V_{GS}=0V, V_{DS}=0V,$ $f=1MHz$
-----------------	-------	---	------	-----	----------	-------------------------------------

Body Diode Characteristic

Parameter	Symbol	Value			Unit	Test Condition
		min.	typ.	max.		
Body Diode Forward Voltage	V_{SD}	0.7	1.00	1.30	V	$V_{GS}=0V, I_{SD}=40A$
Body Diode Continuous Forward Current	I_S	-	-	75	A	TC = 25°C
Body Diode Pulsed Current	I_S pulse	-	-	300	A	TC = 25°C
Body Diode Reverse Recovery Time	t_{rr}	49.26	73.89	110.835	ns	$I_F=40A, dI/dt=100A/\mu s$
Body Diode Reverse Recovery Charge	Q_{rr}	114.67	172	258	nC	

Typical Performance Characteristics

Fig 1: Output Characteristics

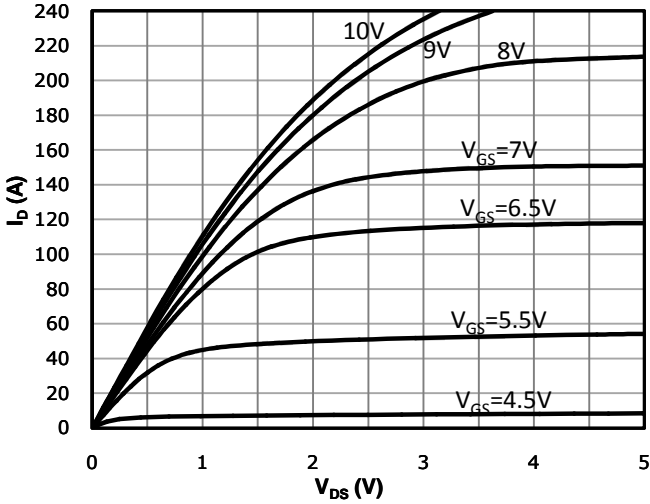

Fig 2: Transfer Characteristics

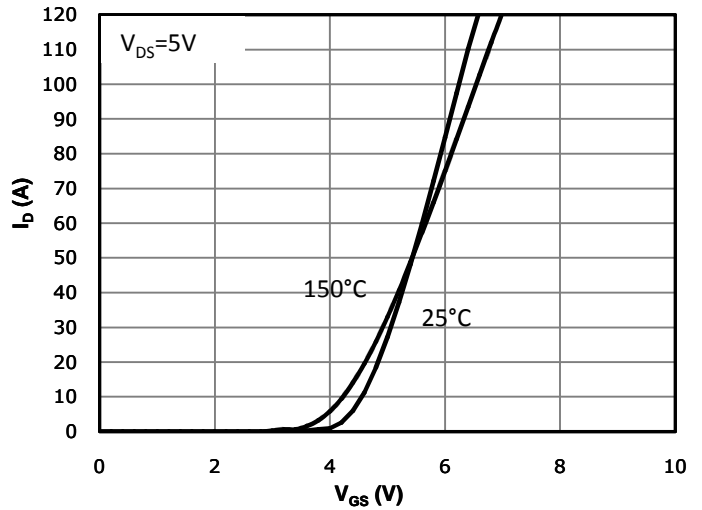

Fig 3: $R_{DS(on)}$ vs Drain Current and Gate Voltage

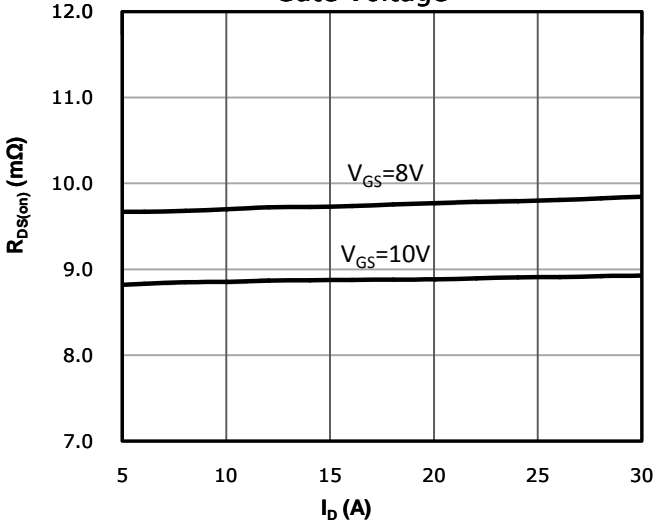

Fig 4: $R_{DS(on)}$ vs Gate Voltage

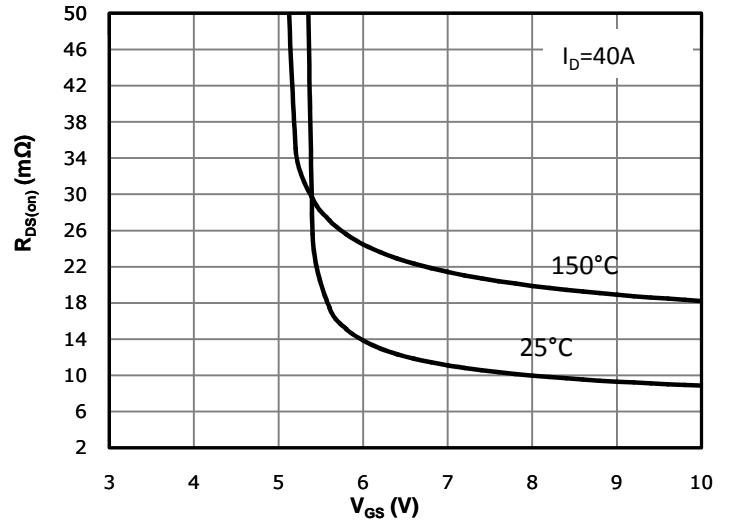

Fig 5: $R_{DS(on)}$ vs. Temperature

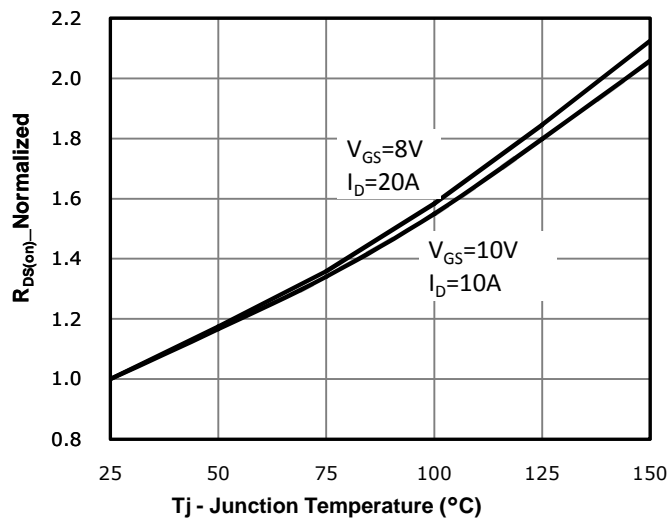

Fig 6: Capacitance Characteristics

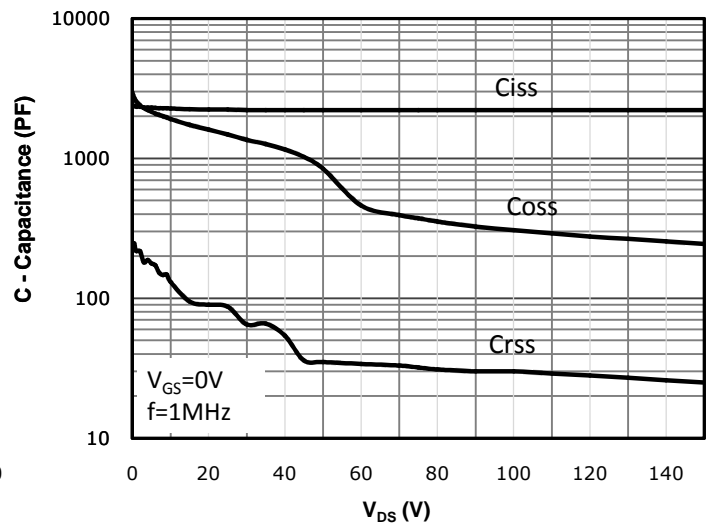

Fig 7: Gate Charge Characteristics

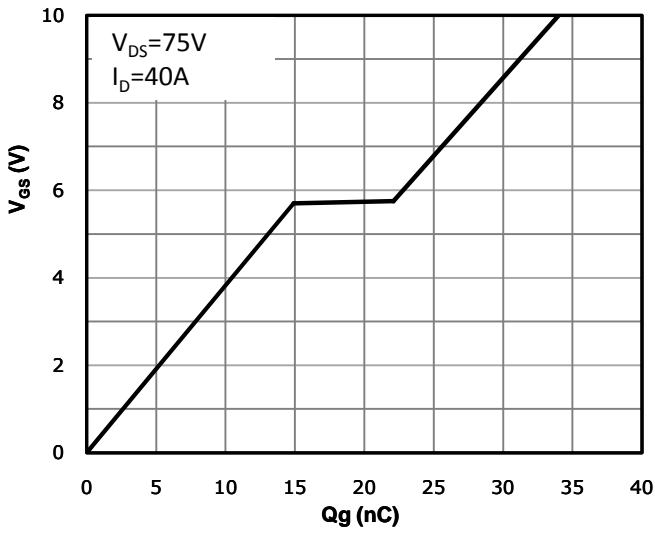

Fig 8: Body-diode Forward Characteristics

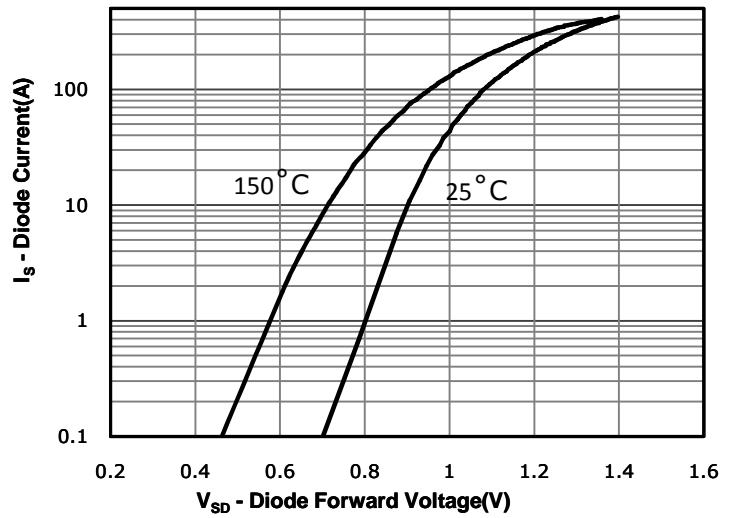

Fig 9: Power Dissipation

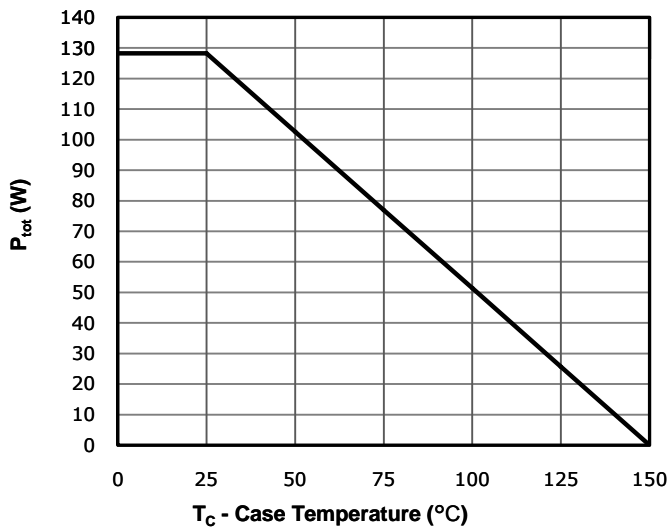

Fig 10: Drain Current Derating

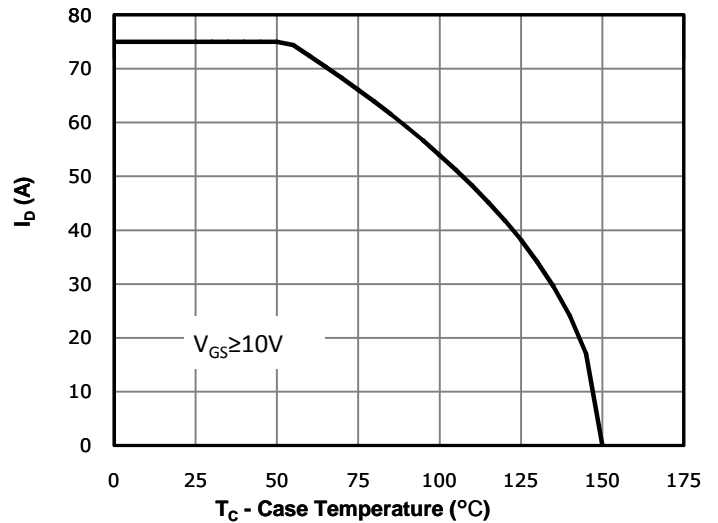

Fig 11: Safe Operating Area

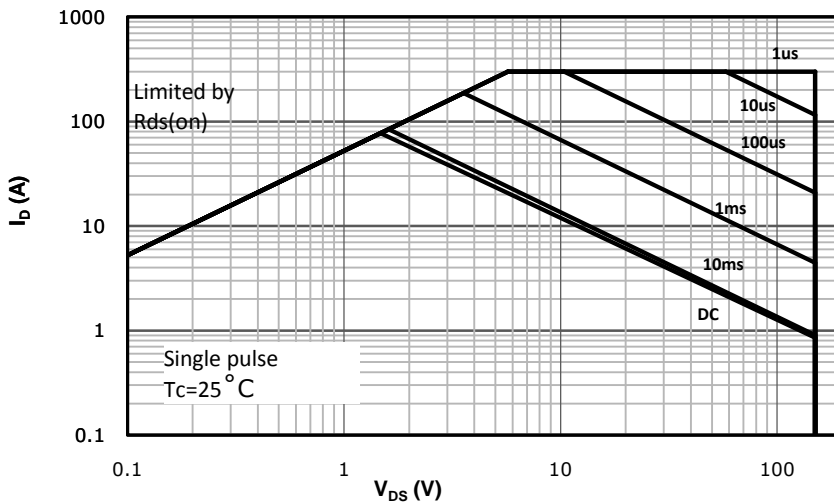
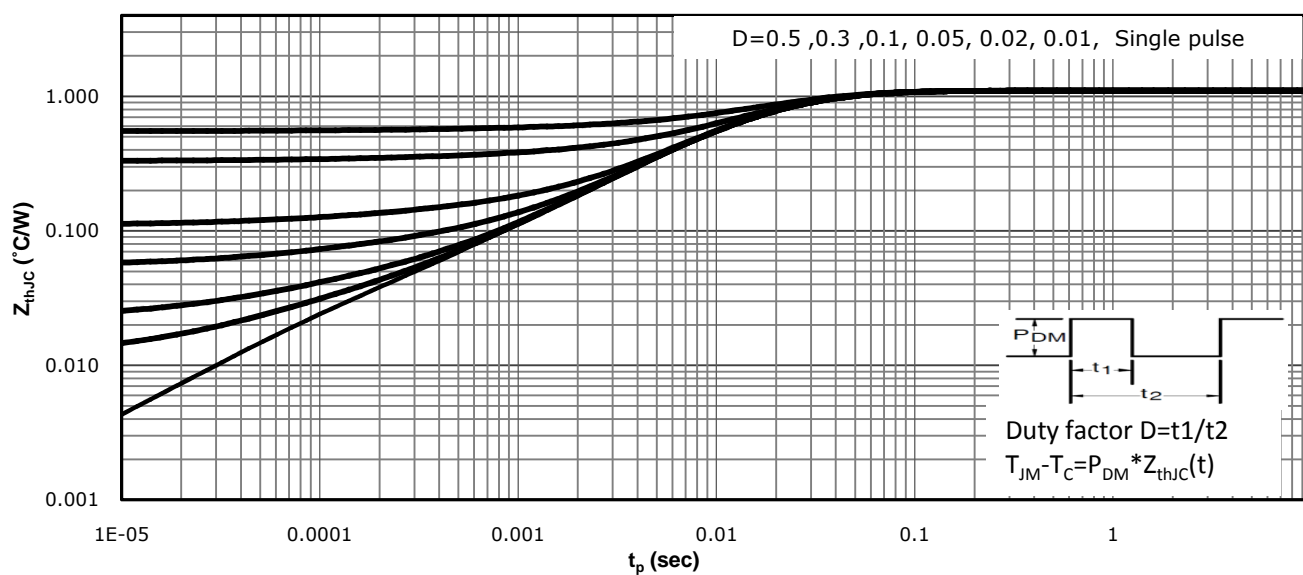
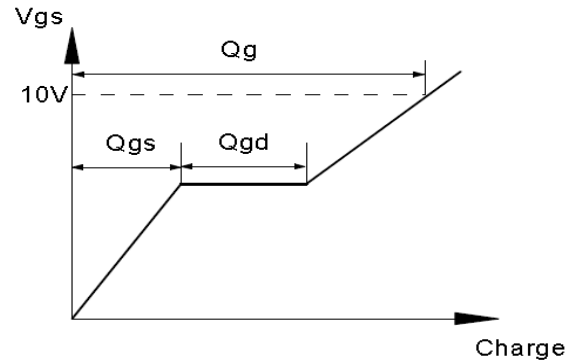
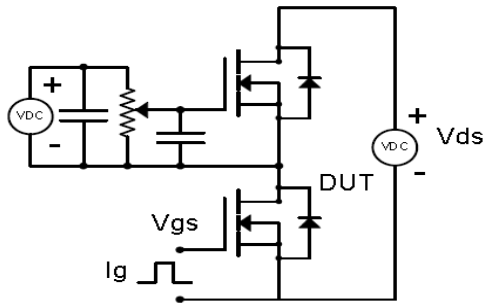

Fig 12: Max. Transient Thermal Impedance



Test Circuit & Waveform

Gate Charge Test Circuit & Waveform



Resistive Switching Test Circuit & Waveforms

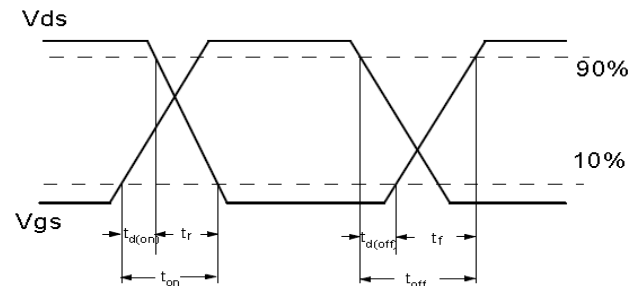
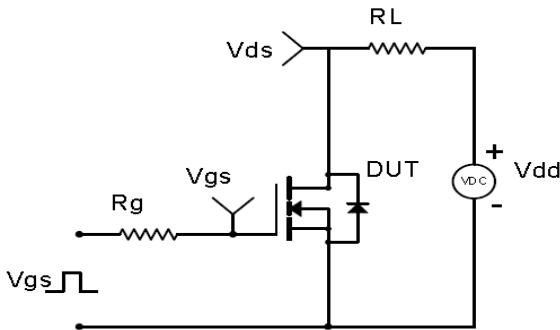

Unclamped Inductive Switching (UIS) Test Circuit & Waveforms

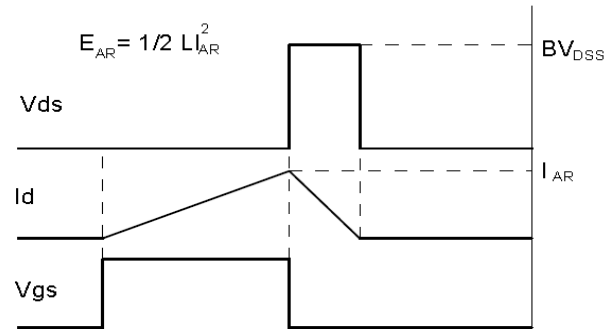
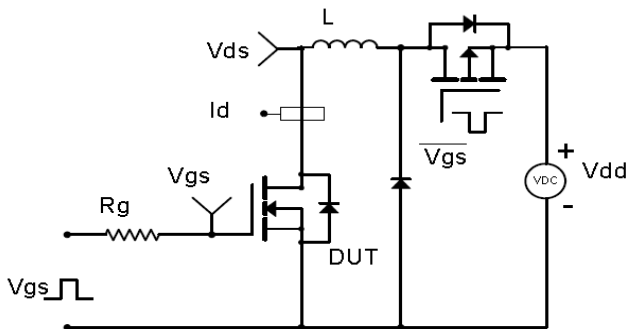

Diode Recovery Test Circuit & Waveforms

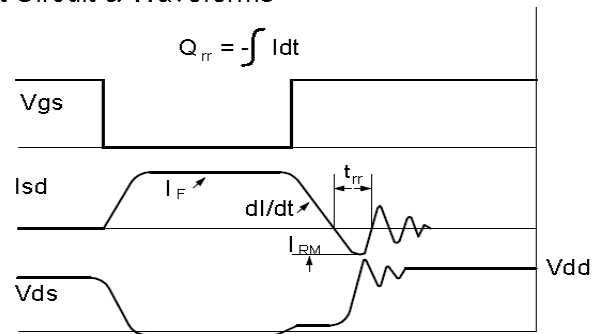
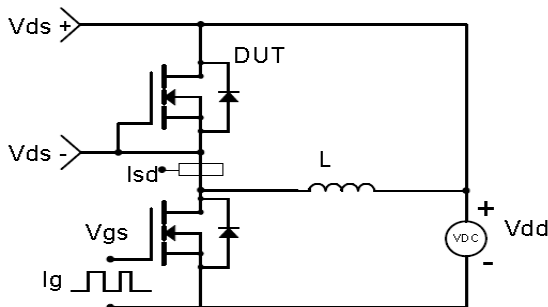

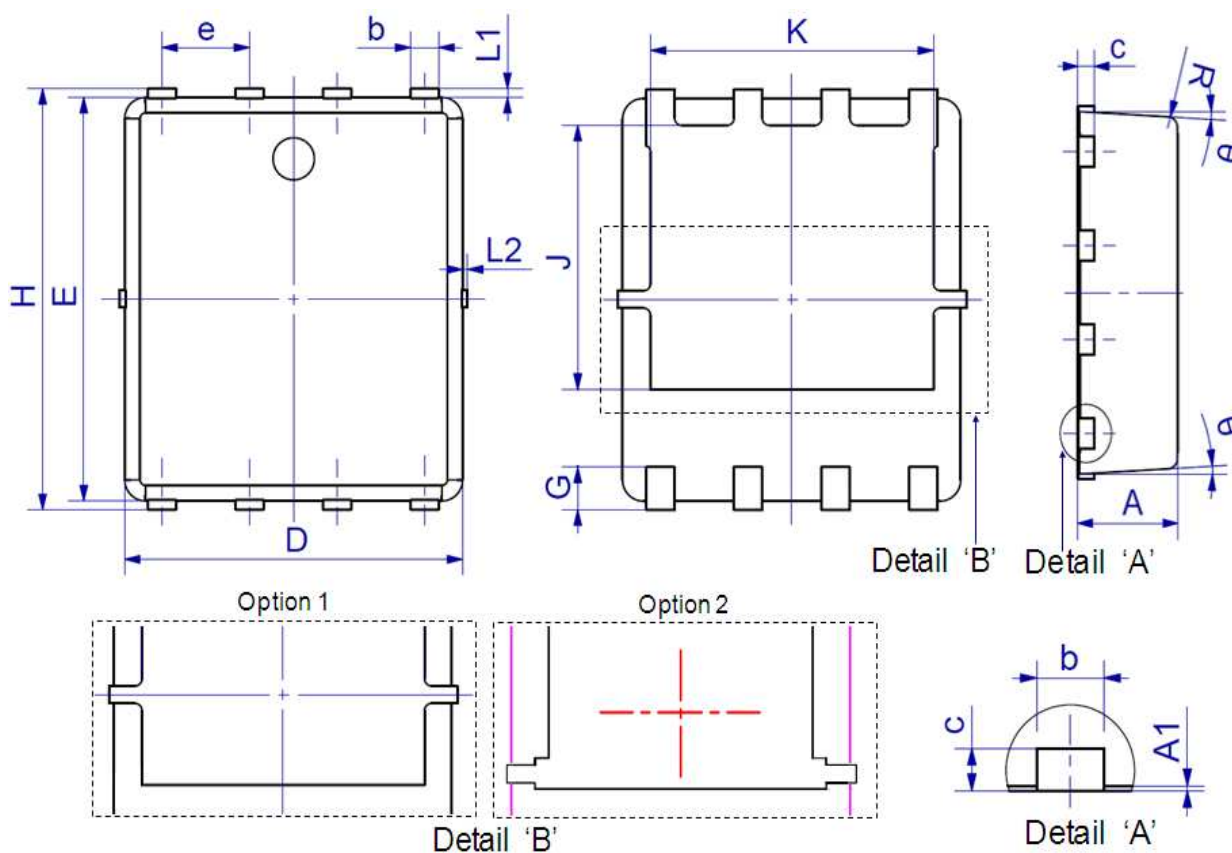
Package Outline: DFN5X6 Cu Clip

Symbol	Dimensions In Millimeters		Dimensions In Inches	
	Min.	Max.	Min.	Max.
A	0.80	1.20	0.031	0.047
A1	0.00	0.05	0.000	0.002
b	0.30	0.51	0.012	0.020
c	0.15	0.35	0.006	0.014
D	4.80	5.40	0.189	0.213
e	1.27 BSC		0.050 BSC	
E	5.66	6.06	0.223	0.239
G	0.30	0.71	0.012	0.028
H	5.90	6.35	0.232	0.250
J	3.32	3.92	0.131	0.154
K	3.61	4.25	0.142	0.167
L1	0.05	0.25	0.002	0.010
L2	0.00	0.15	0.000	0.006
R	0.25 REF		0.010 REF	
θ	0°	12°	0°	12°

Marking



NOTE:

NXBBAAAAY

N	—Wire Bond code
X	—Assembly location code
BB	—Fab code
AAAA	—Lot code
Y	—Bin code

Revision History

Revision	Date	Major changes
1.0	2020-6-30	Release of Preliminary Version.
2.0	2020-9-15	Supplement Dynamic Upper/Lower Limit

Disclaimer

Unless otherwise specified in the datasheet, the product is designed and qualified as a standard commercial product and is not intended for use in applications that require extraordinary levels of quality and reliability, such as automotive, aviation/aerospace and life-support devices or systems.

Any and all semiconductor products have certain probability to fail or malfunction, which may result in personal injury, death or property damage. Customer are solely responsible for providing adequate safe measures when design their systems.

CRM(CQ) reserves the right to improve product design, function and reliability without notice.

单击下面可查看定价，库存，交付和生命周期等信息

[>>CRMICRO\(华润微\)](#)