



Features

- High isolation 3750 V_{RMS}
- OFF-state output terminal voltage: 400 V (min)
- Operating Temperature range - 40 °C to 85°C
- Creepage distance ≥ 5mm
- Distance Through Isolation > 0.4mm
- RoHS and REACH Compliance
- Halogen Free Compliance
- MSL class 1
- Regulatory Approvals
 - ✓ UL - UL1577 (E364000)
 - ✓ VDE - EN60747-5-5(VDE0884-5)
 - ✓ CQC – GB4943.1, GB8898 (14001105803)
 - ✓ IEC62368 (FI/41119)

Description

The CTR214-M4 consists of two MOSFET and one photovoltaic chip optically coupled to an Infrared-emitting diode in 4-lead Mini-Flat package.

Applications

- Battery Management System (BMS)
- Security Systems
- Smart Meters
- Mechanical relay replacements
- General telecom switching
- Industrial controls
- Automatic measurement equipment

Package Outline

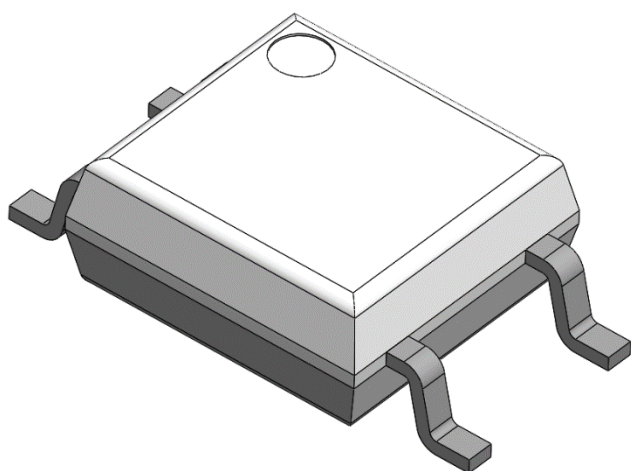

Schematic

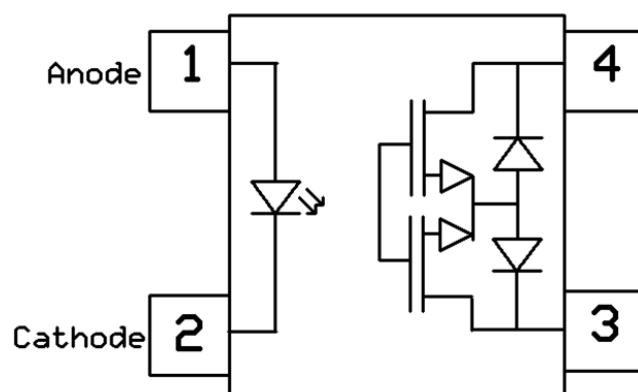



Absolute Maximum Ratings $T_A = 25^{\circ}\text{C}$, unless otherwise specified

Stresses in excess of the absolute maximum ratings can cause permanent damage to the device. Functional operation of the device is not implied at these or any other conditions in excess of those given in the operational sections of this document. In addition, extended exposure to stresses above the recommended operating conditions may affect device reliability. The absolute maximum ratings are stress ratings only.

Symbol	Parameters	Ratings	Units	Notes
V _{ISO}	Isolation voltage (AC, 1 minute, 40 ~ 60% R.H.)	3750	V _{rms}	
T _{OPR}	Operating temperature	-40 ~ +85	°C	
T _{STG}	Storage temperature	-40 ~ +100	°C	
T _{SOL}	Soldering temperature (For 10 seconds)	260	°C	
Emitter				
I _F	LED forward current (50% duty, 1ms P.W)	50	mA	
I _{F(TRANS)}	LED forward current (pulsed) (≤1μs P.W,300pps)	1	A	
V _R	LED reverse voltage	5	V	
P _C	Power dissipation	85	mW	
T _j	Junction Temperature	115	°C	
Detector				
V _{OFF}	OFF-state output terminal Voltage	400	V	
I _{ON}	ON-state Current	CTR214	100	mA
		CTR214B	160	mA
P _O	Output Power dissipation	CTR214	500	mW
		CTR214B	384	mW
T _j	Junction Temperature	125	°C	
T _{jA}	Junction to Ambient Temperature	60	°C	

Recommended Operating Conditions

Symbol	Parameters	Min	Typ	Max	Units
V _{DD}	Supply Voltage	-	-	320	V
I _{FT}	Trigger LED Current	5	10	20	mA
T _{OPR}	Operating temperature	-40	-	60	°C



Electrical Characteristics $T_A = 25^\circ\text{C}$, unless otherwise specified

Emitter Characteristics

Symbol	Parameters	Test Conditions	Min	Typ	Max	Units	Notes
V_F	Forward voltage	$I_F = 10\text{mA}$	-	1.4	1.6	V	
I_R	Reverse Current	$V_R = 6\text{V}$	-	-	5	μA	
C_{IN}	Input Capacitance	$f = 1\text{MHz}$	-	30	-	pF	

Detector Characteristics

Symbol	Parameters	Test Conditions	Min	Typ	Max	Units	Notes
I_{OFF}	OFF-state Current	$V_{OFF} = 400\text{V}$	-	-	1	μA	
C_{OFF}	Output Capacitance	$V_O = 0\text{V}$, $f = 1\text{MHz}$	-	30	-	pF	

Transfer Characteristics

Symbol	Parameters	Test Conditions	Min	Typ	Max	Units	Notes
I_{FT}	Trigger LED Current	$I_{ON} = \text{Max}$	-	1.5	3	mA	
R_{ON}	ON-state resistance	CTR214-M4	-	-	50	Ω	1
		CTR214B-M4					

Switching Characteristics

Symbol	Parameters	Test Conditions	Min	Typ	Max	Units	Notes
T_{ON}	Turn-on Time	CTR214-M4	-	0.17	1	ms	
		CTR214B-M4		0.14			
T_{OFF}	Turn-off Time	CTR214-M4	-	0.18	1	ms	
		CTR214B-M4		0.24			



Typical Characteristic Curves $T_A = 25^\circ\text{C}$, unless otherwise specified

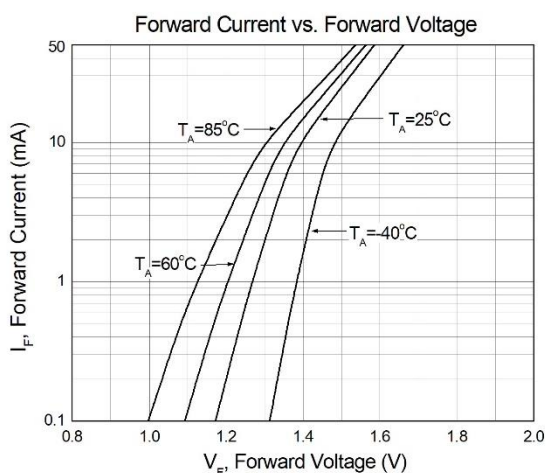

Figure 1

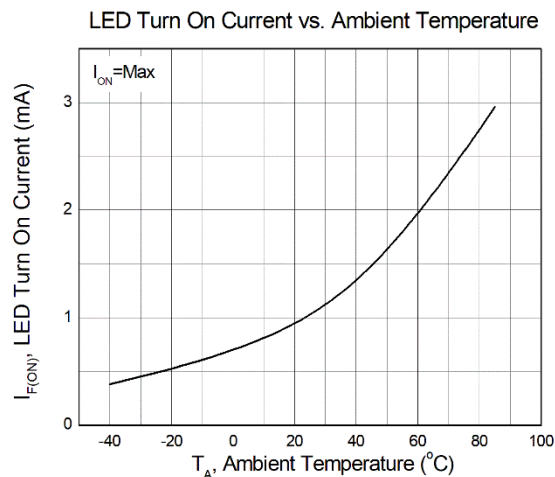

Figure 2

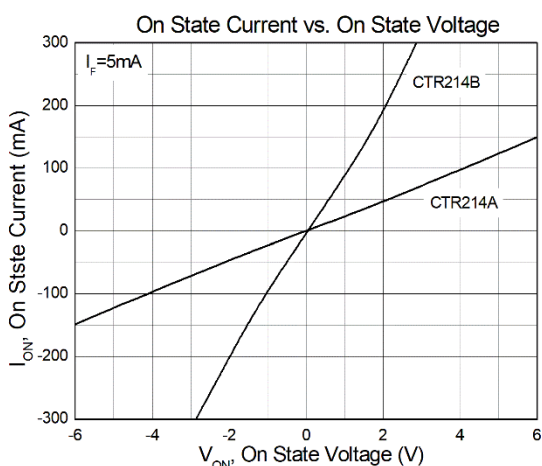

Figure 3

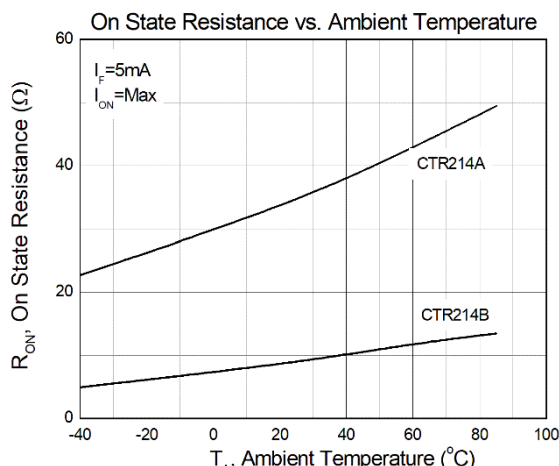

Figure 4

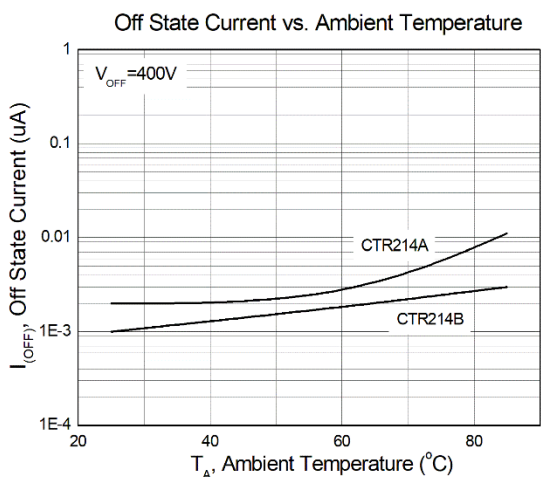

Figure 5

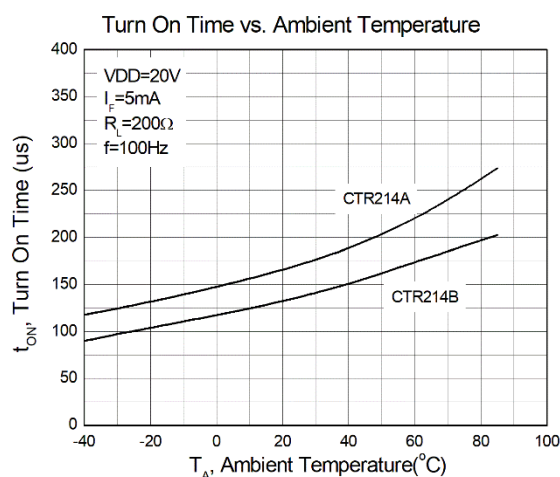

Figure 6



Typical Characteristic Curves $T_A = 25^\circ\text{C}$, unless otherwise specified

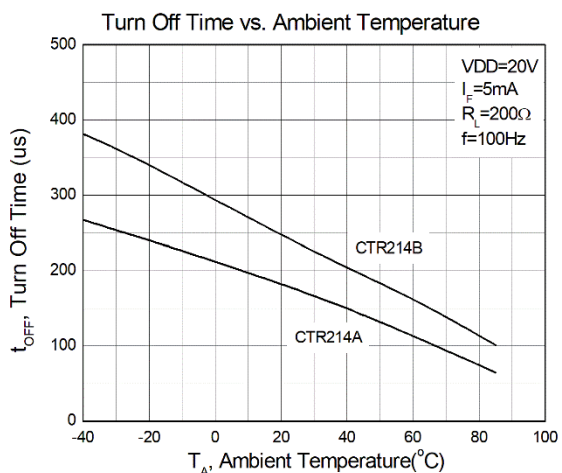

Figure 7

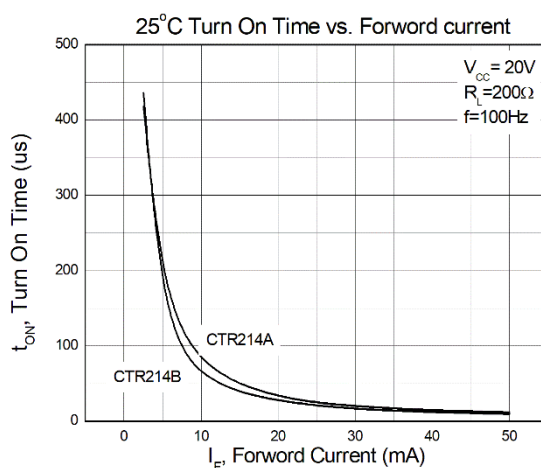

Figure 8

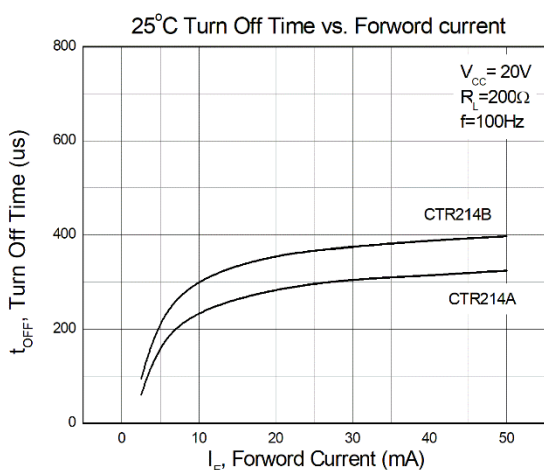

Figure 9



Test Circuit

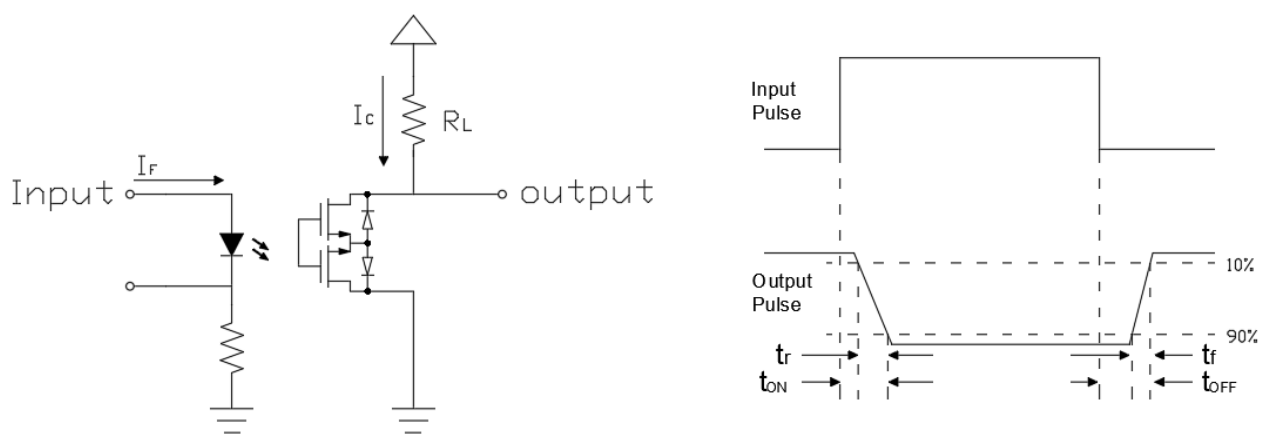
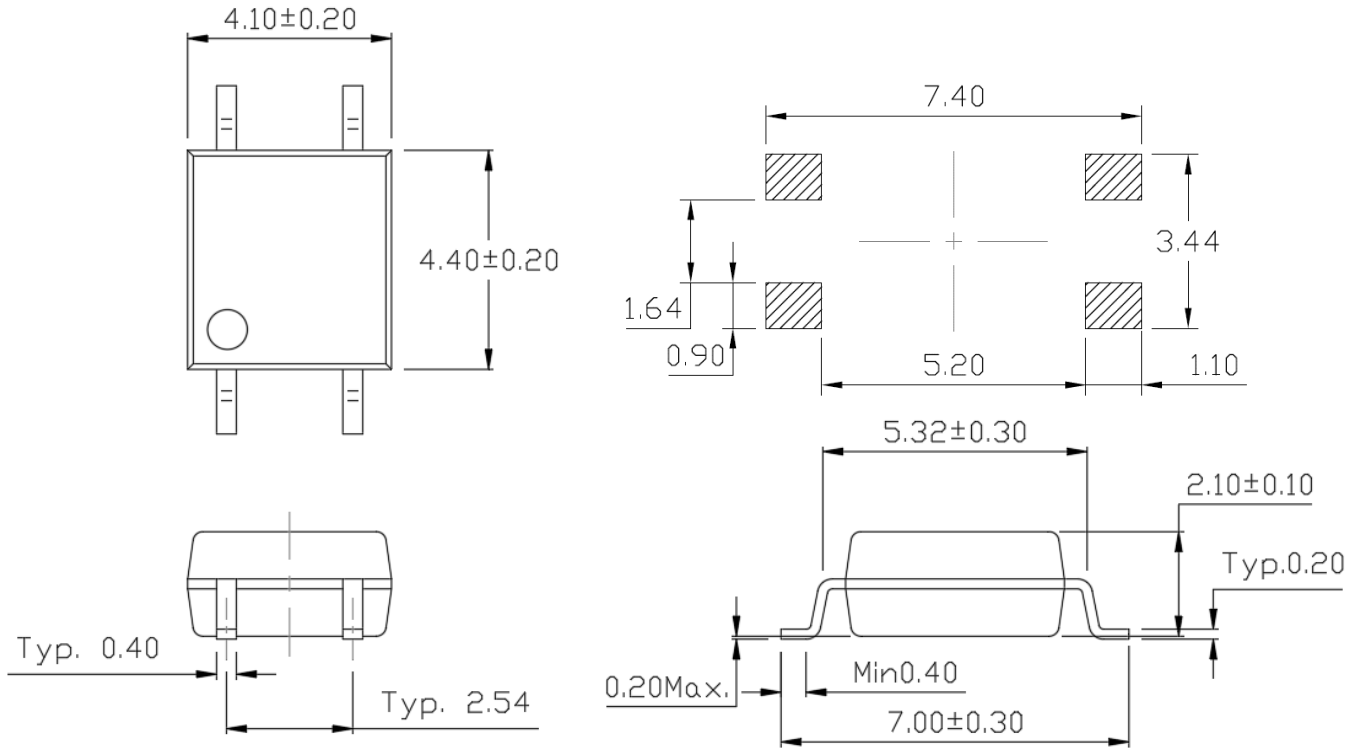

Figure 10: Switching Time Test Circuits



Package Dimension *Dimensions in mm unless otherwise stated*



Marking Information



Note:

- CT : Denotes "CT Micro"
- R214 : Part Number
- X : Option (Blank or B)
- V : VDE Safety Mark Option (Blank or V)
- Y : One Digit Year Code
- WW : Two Digit Work Week
- K : Manufacturing Code



www.ct-micro.com

CTR214-M4

4-Pin Mini-Flat DMC-Isolator®

PhotoMOS Relays

Ordering Information

CTR214(X)(V)(Z)-M4

- CT = Denotes "CT Micro"
- R214 = Part Number
- X = Option (Blank or B)
- V = VDE Safety Mark Option (Blank or V)
- Z = Tape and Reel Option (T1 or T2)
- M4 = MFP Package

Option	Description	Quantity
T1	Surface Mount Lead Forming – With Option 1 Tapping	3000 Units/Reel
T2	Surface Mount Lead Forming – With Option 2 Tapping	3000 Units/Reel

Reel Dimension *All dimensions are in mm, unless otherwise stated*

Option T1/T2

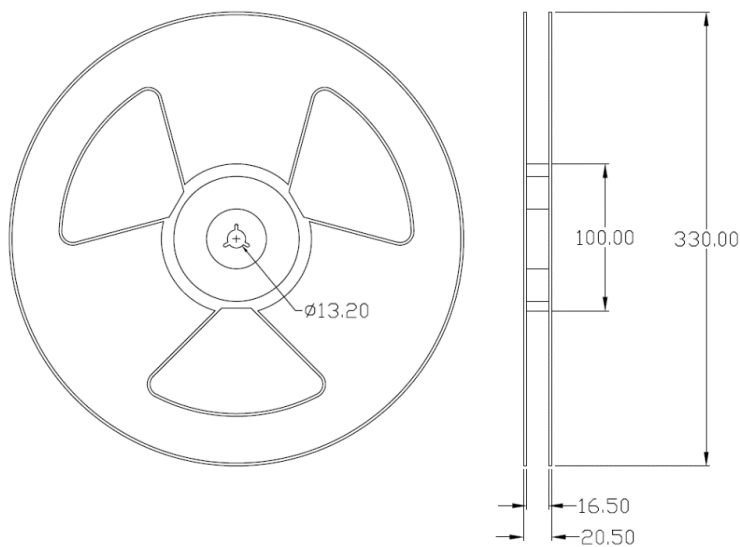



Carrier Tape Specifications *Dimensions in mm unless otherwise stated*

Option T1

Input Direction
→

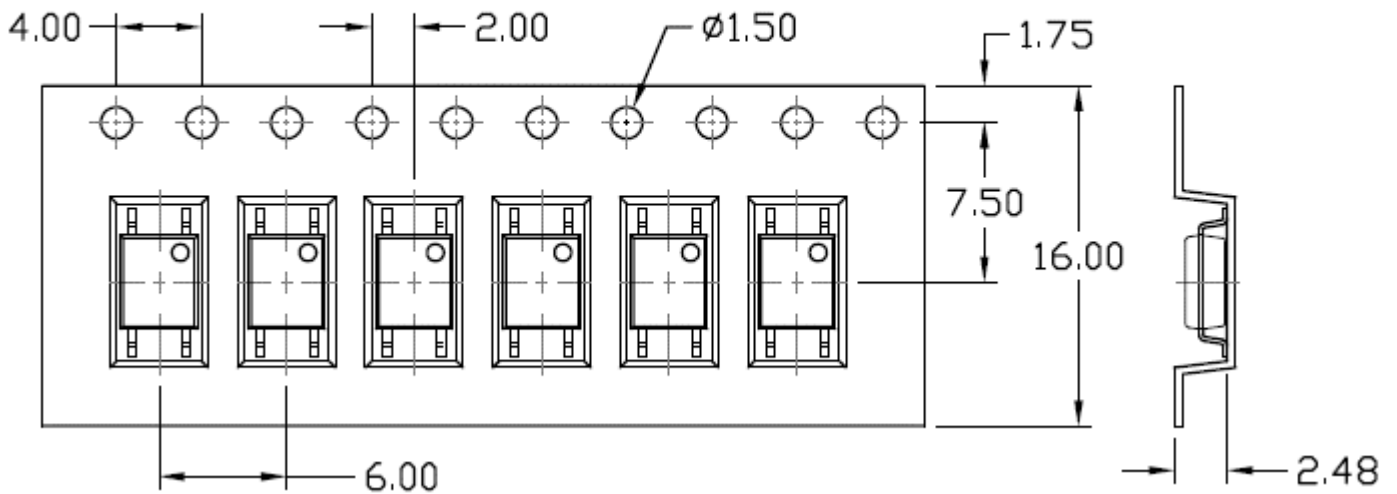

Option T2

Input Direction
→

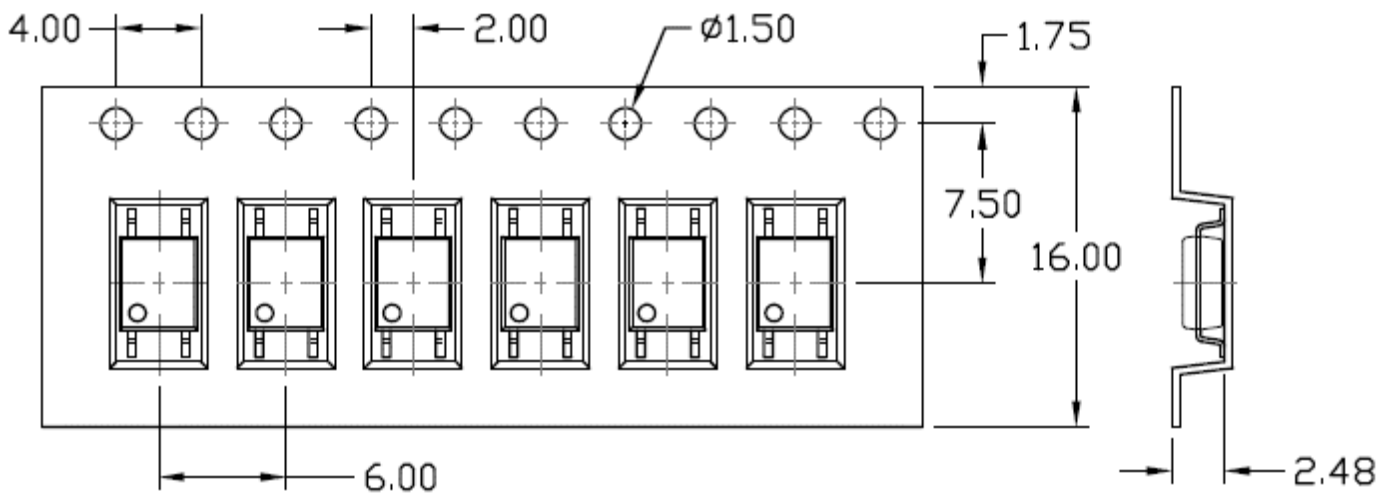



Solderability spec (Follow the JEDEC standard JESD22-B102)

Reflow Soldering: Immersed surface, other than the end of pin as cut-surface, must be covered by solder.

Solder-Bath: More than 95% of the electrode must be covered with solder.

Wave soldering (Follow the JEDEC standard JESD22-A111)

One time soldering is recommended within the condition of temperature.

Temperature: $260 \pm 0/-5^\circ\text{C}$.

Time: 10 sec.

Preheat temperature: 25 to 140°C .

Preheat time: 30 to 80 sec.

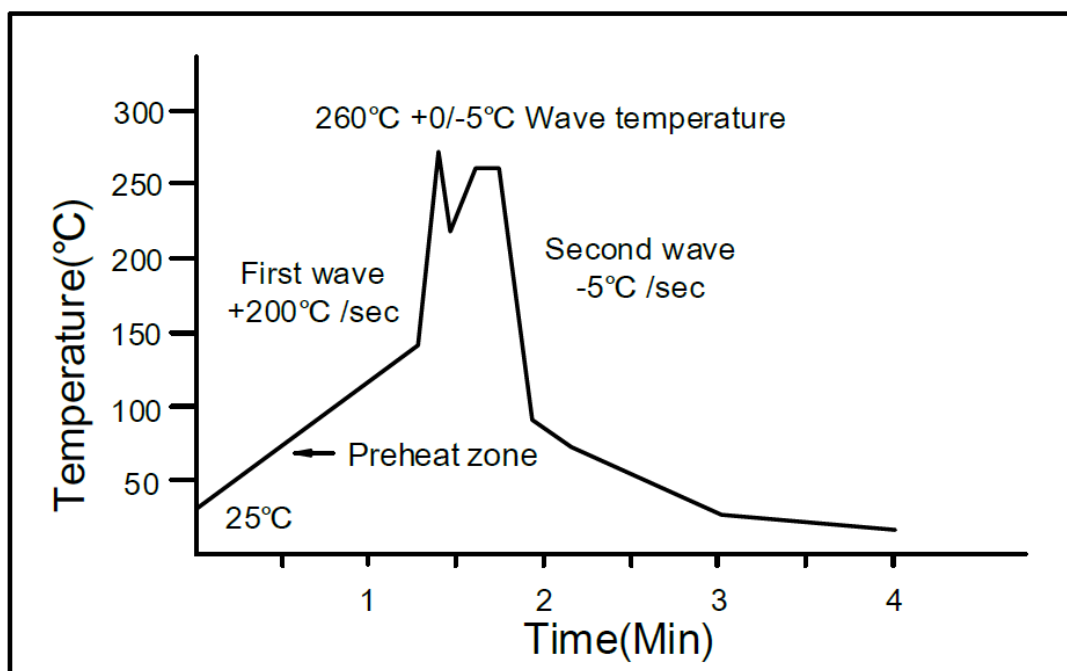

Iron soldering (Follow the standard MIL-STD 202G, Method 210F)

Allow single lead soldering in every single process.

One time soldering is recommended. Temperature: $350 \pm 10^\circ\text{C}$

Time: 5 sec max.



Reflow Profile (Follow the JEDEC standard J-STD-020)

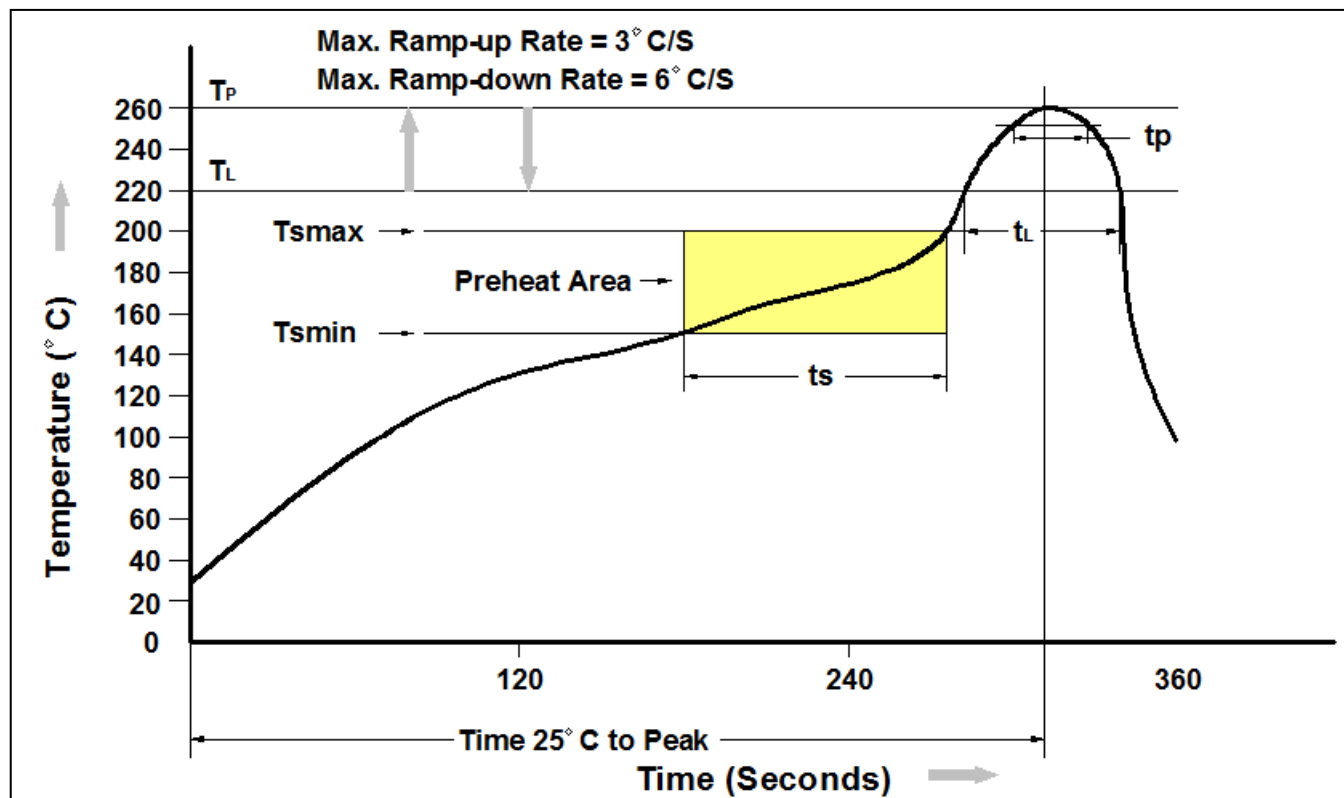

Profile Feature	Pb-Free Assembly Profile
Temperature Min. (Tsmmin)	150°C
Temperature Max. (Tsmmax)	200°C
Time (ts) from (Tsmmin to Tsmmax)	60-120 seconds
Ramp-up Rate (tL to tp)	3°C/second max.
Liquidous Temperature (TL)	217°C
Time (tL) Maintained Above (TL)	60 – 150 seconds
Peak Body Package Temperature	260°C +0°C / -5°C
Time (tp) within 5°C of 260°C	30 seconds
Ramp-down Rate (TP to TL)	6°C/second max
Time 25°C to Peak Temperature	8 minutes max.



DISCLAIMER

DMC-Isolator® IS A TRADEMARK OF CT MICRO INTERNATIONAL CORPORATION AND/OR ITS SUBSIDIARIES. CT MICRO OWNS THE RIGHTS TO A NUMBER OF PATENTS, TRADEMARKS, COPYRIGHTS AND OTHER INTELLECTUAL PROPERTY.

CT MICRO RESERVES THE RIGHT TO MAKE CHANGES WITHOUT FURTHER NOTICE TO ANY PRODUCTS HEREIN TO IMPROVE RELIABILITY, FUNCTION OR DESIGN. CT MICRO DOES NOT ASSUME ANY LIABILITY ARISING OUT OF THE APPLICATION OR USE OF ANY PRODUCT OR CIRCUIT DESCRIBED HEREIN; NEITHER DOES IT CONVEY ANY LICENSE UNDER ITS PATENT RIGHTS, NOR THE RIGHTS OF OTHERS.

DISCOLORATION MIGHT OCCUR ON THE PACKAGE SURFACE AFTER SOLDERING, REFLOW OR LONG TERM USE. THIS DOES NOT IMPACT THE PRODUCT PERFORMANCE NOR THE PRODUCT RELIABILITY.

CT MICRO ARE NOT AUTHORIZED FOR USE AS CRITICAL COMPONENTS IN LIFE SUPPORT DEVICES OR SYSTEMS WITHOUT EXPRESS WRITTEN APPROVAL OF CT MICRO INTERNATIONAL CORPORATION.

- 1. Life support devices or systems are devices or systems which, (a) are intended for surgical implant into the body, or (b) support or sustain life, or (c) whose failure to perform when properly used in accordance with instruction for use provided in the labelling, can be reasonably expected to result in significant injury to the user.*
- 2. A critical component is any component of a life support device or system whose failure to perform can be reasonably expected to cause the failure of the life support device or system, or to affect its safety or effectiveness.*

单击下面可查看定价，库存，交付和生命周期等信息

[>>CT-MICRO\(兆龙科技\)](#)