



CTM3031, CTM3032, CTM3033

CTM3041, CTM3042, CTM3043

250V/400V Zero Cross MFP-4L Phototriac Optocoupler

Features

- High isolation 5000 VRMS
- Peak Breakdown Voltage
 - 250V – CTM3031,3032,3033
 - 400V – CTM3041,3042,3043
- Temperature range - 55 °C to 100 °C
- Regulatory Approvals
 - UL - UL1577 (E364000)
 - VDE - EN60747-5-5(VDE0884-5)
 - CQC – GB4943.1, GB8898
 - IEC60065, IEC60950
- Green Package

Description

The CTM3031, CTM3032, CTM3033, CTM3041, CTM3042 and CTM3043 consists of a Zero Cross Photo Triac optically coupled to a gallium arsenide Infrared-emitting diode in a MFP-4L package.

Applications

- Motor Controls
- Lamp ballasts
- Static AC Power Switch
- Solenoid/ Valve Control

Package Outline

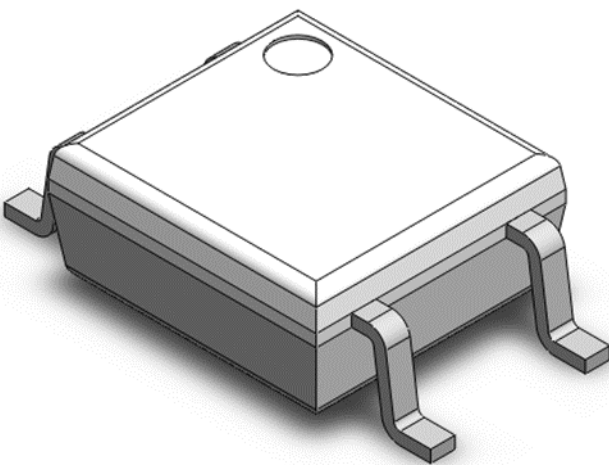

Schematic

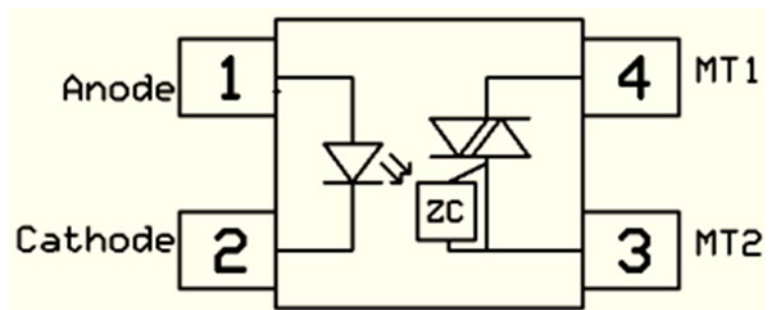

Note: Different lead forming options available. See package dimension.



CTM3031, CTM3032, CTM3033

CTM3041, CTM3042, CTM3043

250V/400V Zero Cross MFP-4L Phototriac Optocouple

Absolute Maximum Rating at 25°C

Symbol	Parameters	Ratings	Units	Notes
V _{ISO}	Isolation voltage	3750	V _{RMS}	
T _{OPR}	Operating temperature	-55 ~ +100	°C	
T _{STG}	Storage temperature	-55 ~ +150	°C	
T _{SOL}	Soldering temperature	260	°C	
Emitter				
I _F	Forward current	60	mA	
I _{F(TRANS)}	Peak transient current (≤1μs P.W,300pps)	1	A	
V _R	Reverse voltage	6	V	
P _D	Power dissipation	100	mW	
Detector				
P _D	Power dissipation	300	mW	
V _{DRM}	Off-State Output Terminal Voltage	CTM3031,3032,3033	250	V
		CTM3041,3042,3043	400	V
I _{TSM}	Peak Repetitive Surge Current	1	A	



CTM3031, CTM3032, CTM3033

CTM3041, CTM3042, CTM3043

250V/400V Zero Cross MFP-4L Phototriac Optocouple

Electrical Characteristics $T_A = 25^\circ\text{C}$ (unless otherwise specified)

Emitter Characteristics

Symbol	Parameters	Test Conditions	Min	Typ	Max	Units	Notes
V_F	Forward voltage	$I_F = 10\text{mA}$	-	-	1.5	V	
I_R	Reverse Current	$V_R = 6\text{V}$	-	-	5	μA	
C_{IN}	Input Capacitance	$f = 1\text{MHz}$	-	45	-	pF	

Detector Characteristics

Symbol	Parameters	Test Conditions	Min	Typ	Max	Units	Notes
I_{DRM1}	Peak Blocking Current	$I_F = 0\text{mA}$, $V_{DRM} = \text{Rated } V_{DRM}$	-	-	100	nA	
I_{DRM2}	Inhibit Leakage Current	$I_F = \text{Rated } I_{FT}$, $V_{DRM} = \text{Rated } V_{DRM}$	-	-	500	μA	
V_{INH}	Inhibit Voltage	$I_F = \text{Rated } I_{FT}$	-	-	20	V	
V_{TM}	Peak On-State Voltage	$I_F = \text{Rated } I_{FT}$, $I_{TM} = 100\text{mA}$	-	-	3	V	
dv/dt	Critical Rate of Rise off-State Voltage	$V_{PEAK} = \text{Rated } V_{DRM}$	1000	-	-	V/ μs	

Transfer Characteristics

Symbol	Parameters	Test Conditions	Min	Typ	Max	Units	Notes
I_{FT}	Input Trigger Current	Terminal Voltage = 3V $I_{TM} = 100\text{mA}$	-	-	15	mA	
					10		
					5		
I_H	Holding Current		-	270	-	μA	
R_{IO}	Isolation Resistance	$V_{IO} = 500\text{V}_{DC}$	1×10^{11}	-	-		
C_{IO}	Isolation Capacitance	$f = 1\text{MHz}$	-	0.25	-	pF	



Typical Characteristic Curve

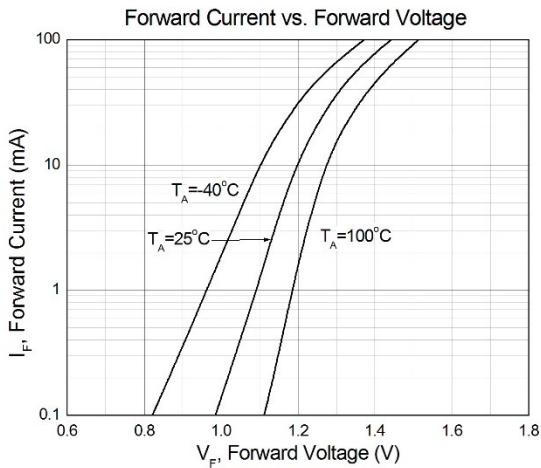

Figure 1

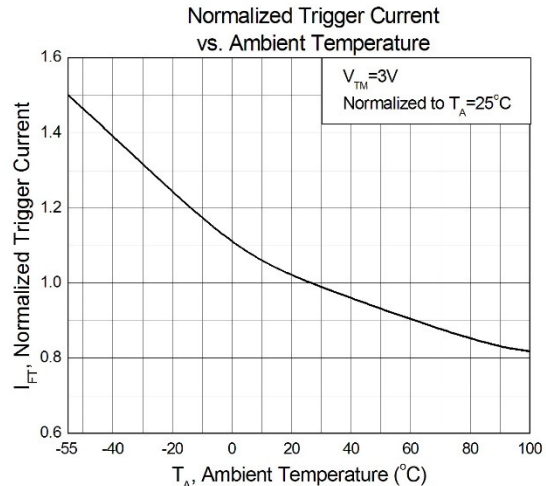

Figure 2

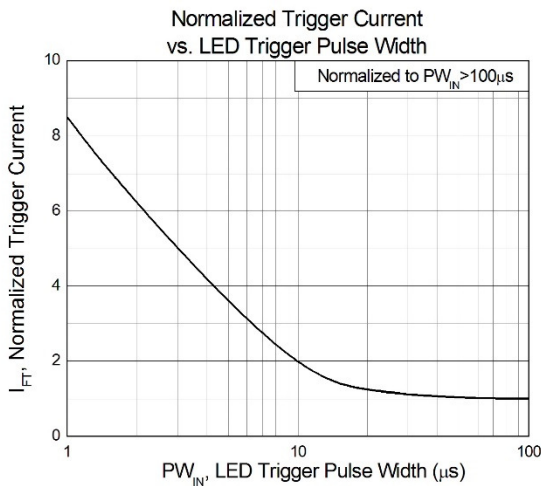

Figure 3

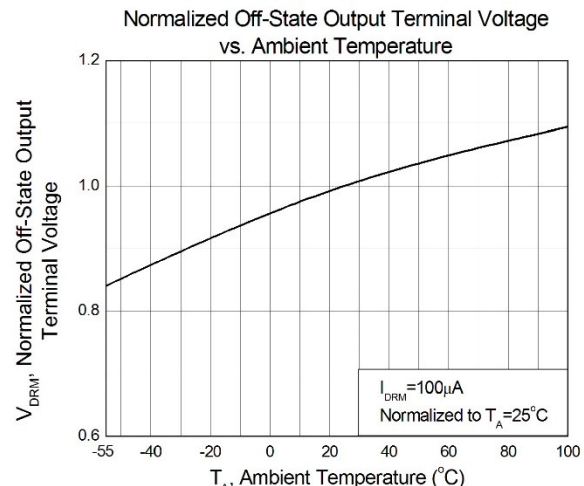

Figure 4

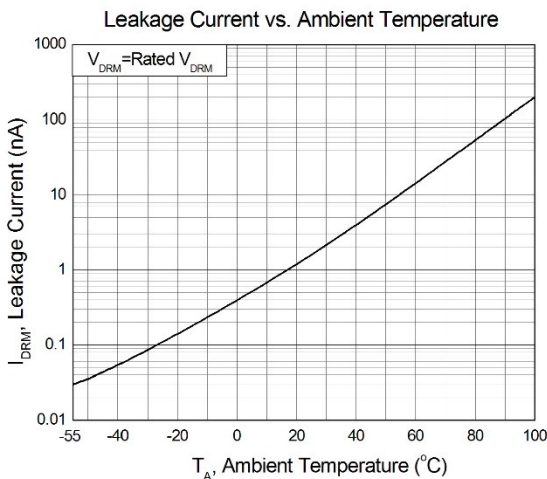

Figure 5

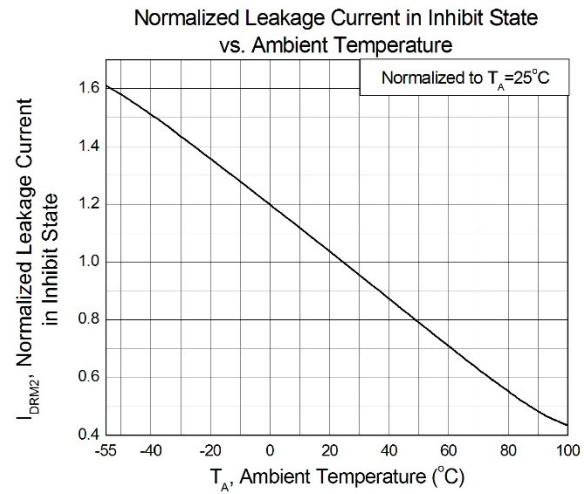

Figure 6



CTM3031, CTM3032, CTM3033

CTM3041, CTM3042, CTM3043

250V/400V Zero Cross MFP-4L Phototriac Optocouple

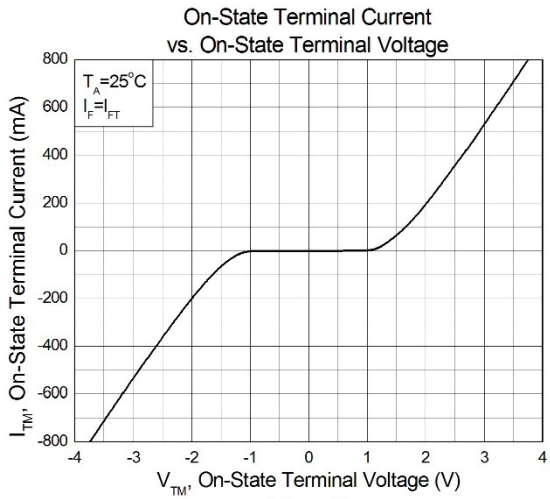

Figure 7

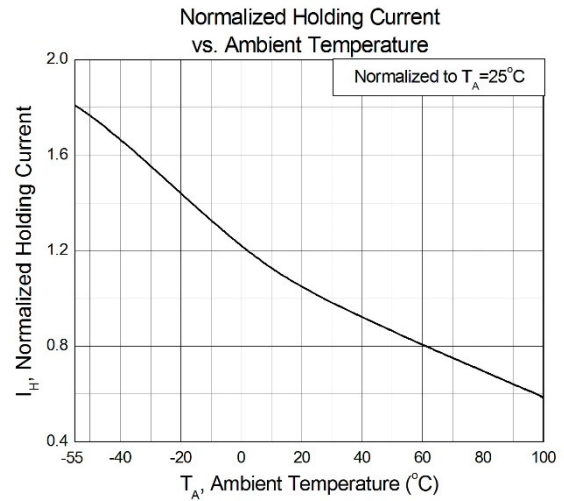

Figure 8

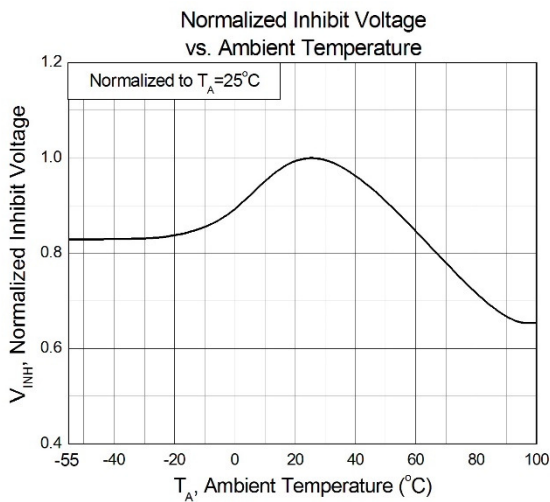

Figure 9



CTM3031, CTM3032, CTM3033

CTM3041, CTM3042, CTM3043

250V/400V Zero Cross MFP-4L Phototriac Optocoupler

Package Dimension *Dimensions in mm unless otherwise stated*

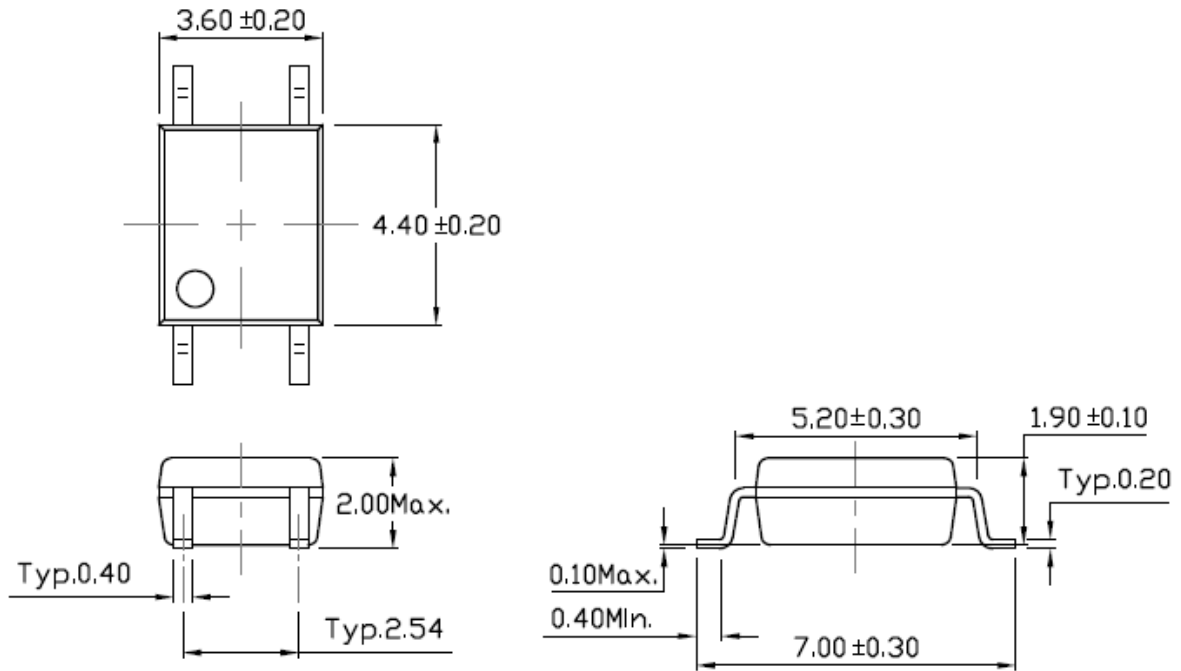

Recommended Solder Mask *Dimensions in mm unless otherwise stated*

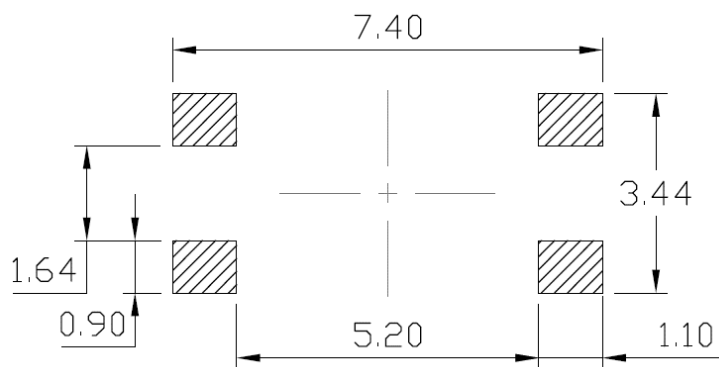



CTM3031, CTM3032, CTM3033

CTM3041, CTM3042, CTM3043

250V/400V Zero Cross MFP-4L Phototriac Optocouple

Marking Information



Note:

CT : Denotes "CT Micro"

3043 : Product Number

V : VDE Option

Y : Fiscal Year

WW : Work Week

K : Manufacturing Code

Ordering Information

CTM30XX(V)(Z)

XX = Part No. (XX=31, 32, 33, 41, 42 or 43)

V = VDE Option (V or None)

Z = Tape and reel option (T1 or T2)

Option	Description	Quantity
T1	Surface Mount Lead Forming – With Option 1 Taping	3000 Units/Reel
T2	Surface Mount Lead Forming – With Option 2 Taping	3000 Units/Reel



CTM3031, CTM3032, CTM3033

CTM3041, CTM3042, CTM3043

250V/400V Zero Cross MFP-4L Phototriac Optocoupler

Carrier Tape Specifications *Dimensions in mm unless otherwise stated*

Option T1

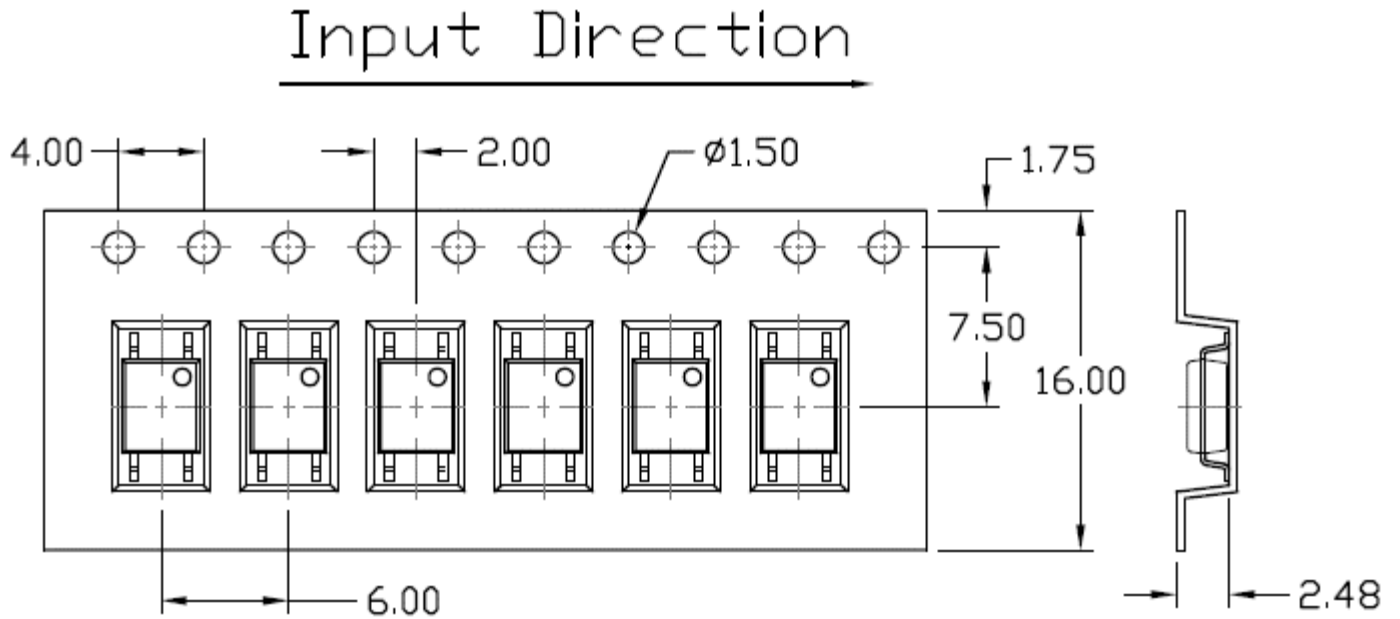

Option T2

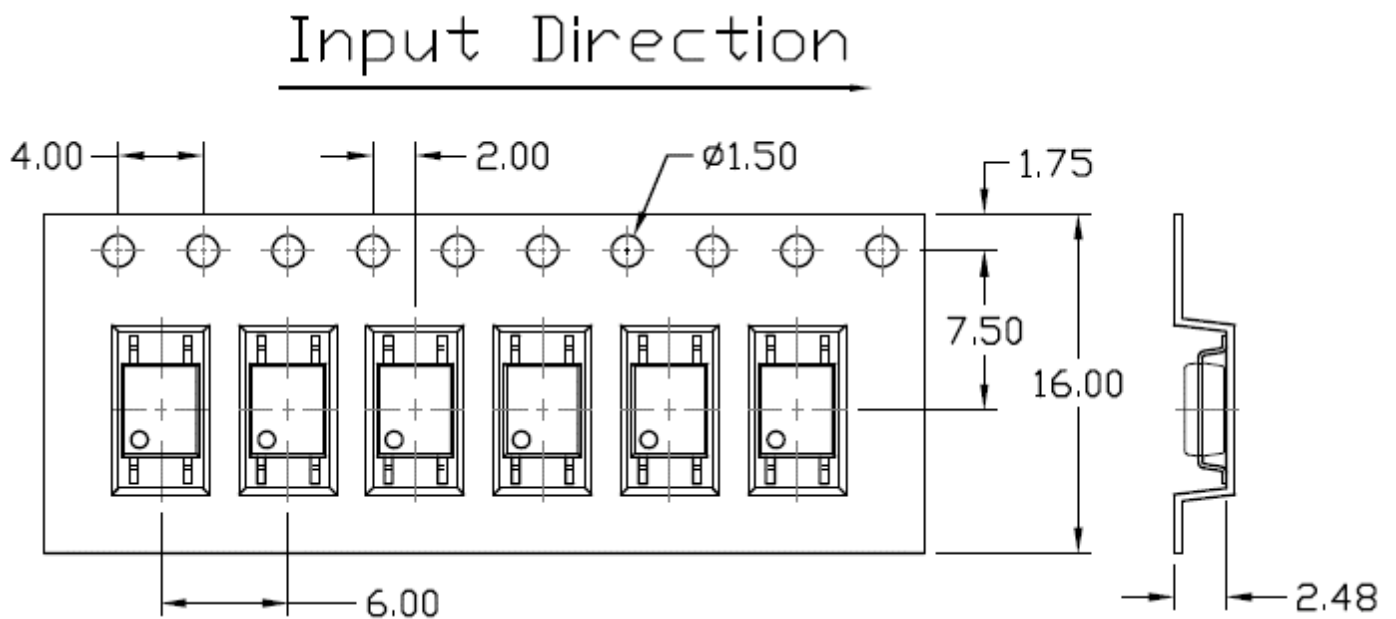



Reflow Profile

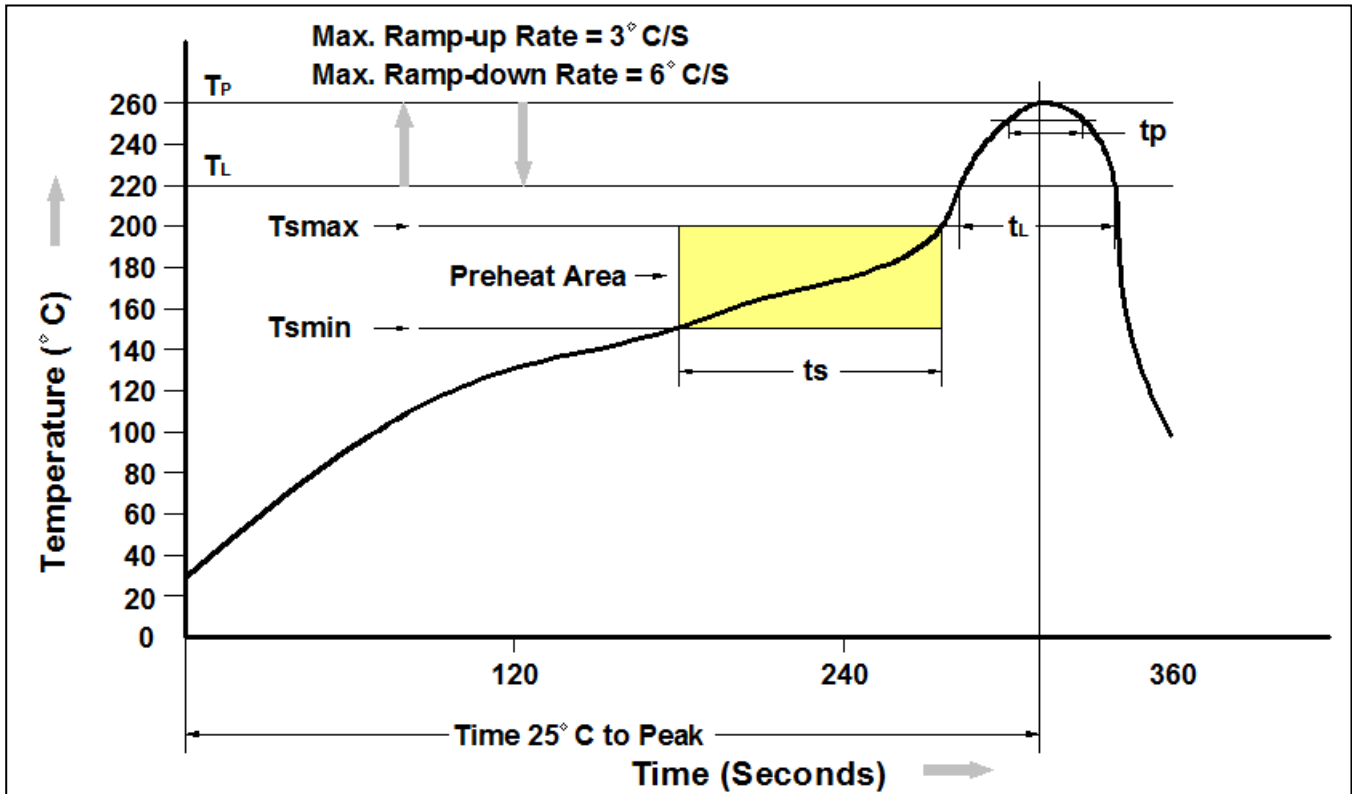

Profile Feature	Pb-Free Assembly Profile
Temperature Min. (T _{smin})	150 °C
Temperature Max. (T _{smax})	200 °C
Time (t _s) from (T _{smin} to T _{smax})	60-120 seconds
Ramp-up Rate (t _L to t _P)	3 °C/second max.
Liquidous Temperature (T _L)	217 °C
Time (t _L) Maintained Above (T _L)	60 – 150 seconds
Peak Body Package Temperature	260 °C +0 °C / -5 °C
Time (t _P) within 5 °C of 260 °C	30 seconds
Ramp-down Rate (T _P to T _L)	6 °C/second max
Time 25 °C to Peak Temperature	8 minutes max.



CTM3031, CTM3032, CTM3033

CTM3041, CTM3042, CTM3043

250V/400V Zero Cross MFP-4L Phototriac Optocouple

DISCLAIMER

CT MICRO RESERVES THE RIGHT TO MAKE CHANGES WITHOUT FURTHER NOTICE TO ANY PRODUCTS HEREIN TO IMPROVE RELIABILITY, FUNCTION OR DESIGN. CT MICRO DOES NOT ASSUME ANY LIABILITY ARISING OUT OF THE APPLICATION OR USE OF ANY PRODUCT OR CIRCUIT DESCRIBED HEREIN; NEITHER DOES IT CONVEY ANY LICENSE UNDER ITS PATENT RIGHTS, NOR THE RIGHTS OF OTHERS.

DISCOLORATION MIGHT OCCUR ON THE PACKAGE SURFACE AFTER SOLDERING, REFLOW OR LONG TERM USE. THIS DOES NOT IMPACT THE PRODUCT PERFORMANCE NOR THE PRODUCT RELIABILITY.

CT MICRO ARE NOT AUTHORIZED FOR USE AS CRITICAL COMPONENTS IN LIFE SUPPORT DEVICES OR SYSTEMS WITHOUT EXPRESS WRITTEN APPROVAL OF CT MICRO INTERNATIONAL CORPORATION.

- 1. Life support devices or systems are devices or systems which, (a) are intended for surgical implant into the body, or (b) support or sustain life, or (c) whose failure to perform when properly used in accordance with instruction for use provided in the labelling, can be reasonably expected to result in significant injury to the user.*
- 2. A critical component is any component of a life support device or system whose failure to perform can be reasonably expected to cause the failure of the life support device or system, or to affect its safety or effectiveness.*

单击下面可查看定价，库存，交付和生命周期等信息

[>>CT-MICRO\(兆龙科技\)](#)