

Description

The AH342 is a bipolar latching hall IC with a pair of complementary push/pull outputs. A dual hall element is used to offset stress induced noise and drift. The robust outputs are capable of sourcing up to 7.4mA and sinking up to 4.4mA. The device contains inherent reverse polarity protection up to the full power supply range.

Pin Assignments

(Top View)

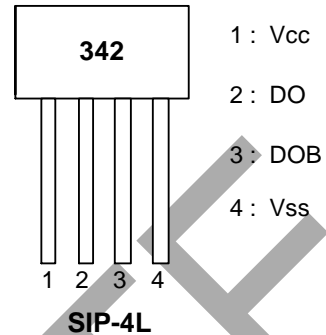

Features

- Digital Dual Complementary Sink/Source Outputs
- Reverse Voltage Polarity Protection for Full Supply Range
- High Output Current Capability
- Low Profile Packages: SIP-4L
- Package: SIP-4L
- **Lead-Free Finish; RoHS Compliant (Notes 1 & 2)**

Applications

- Conveyors
- Motor Control
- Power Sensing
- Linear or Rotary Motion Detection
- RPM Sensing

Notes: 1. EU Directive 2002/95/EC (RoHS), 2011/65/EU (RoHS 2) & 2015/863/EU (RoHS 3) compliant. All applicable RoHS exemptions applied.
 2. See http://www.diodes.com/quality/lead_free/ for more information about Diodes Incorporated's definitions of Halogen- and Antimony-free, "Green" and Lead-free.

Pin Descriptions

Pin Name	P/I/O	Pin #	Description
Vcc	P	1	Power Supply Input
DO	O	2	Output Pin
DOB	O	3	Output Pin
Vss	P	4	Ground

OBSOLETE - PART DISCONTINUED

Functional Block Diagram

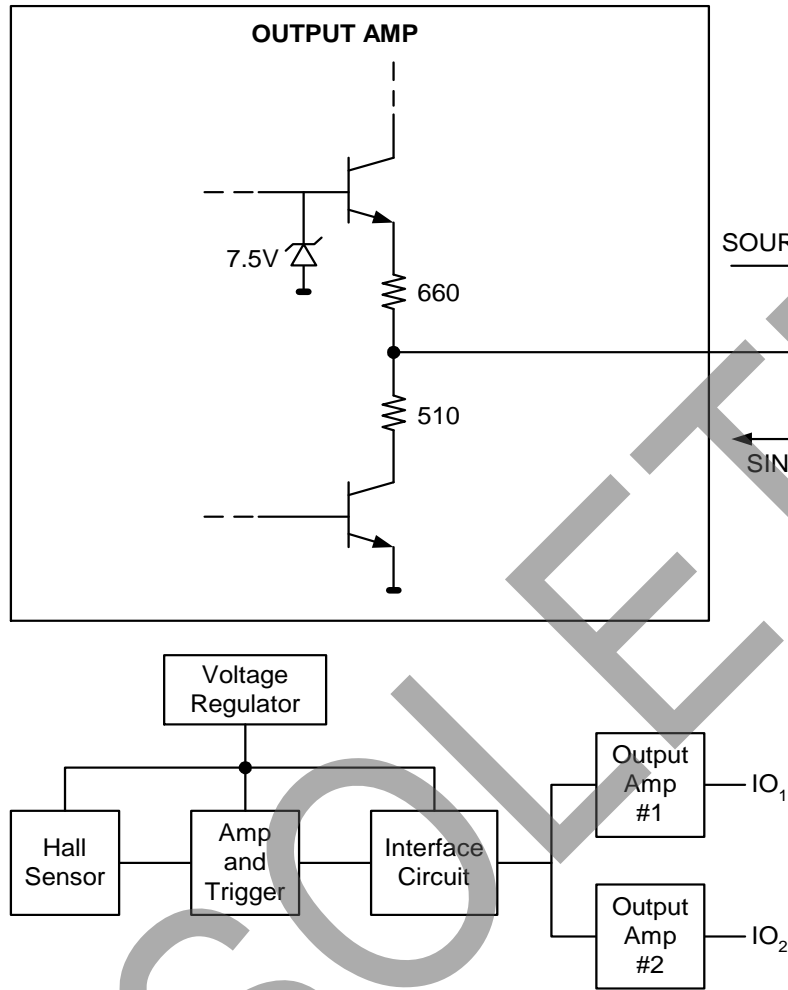

Absolute Maximum Ratings (@ $T_A = +25^\circ\text{C}$, unless otherwise specified.) (Note 3)

Symbol	Parameter	Rating	Unit
V_{CC}	Supply Voltage	± 28	V
V_{out}	Voltage Externally Applied to Output	-1.2 to +5	V
I_c	Output Current	± 10	mA
B	Magnetic Flux Density	Unlimited	Gauss
T_{ST}	Storage Temperature Range	-40 to +150	$^\circ\text{C}$

Note: 3. Absolute maximum ratings are the extreme limits that the device will withstand without damage to the device. However, the electrical and magnetic characteristics are not guaranteed as the maximum limits (above recommended operating conditions) are approached nor will the device necessarily operate at absolute maximum rating.

Recommended Operating Conditions (@ $T_A = +25^\circ\text{C}$, unless otherwise specified.)

Symbol	Characteristic	Conditions	Min	Max	Unit
V_{CC}	Supply Voltage	Operating	4.5	28	V
T_A	Operating Ambient Temperature (Note 4)	Operating	-40	+125	$^\circ\text{C}$

Note: 4. Shall not exceed P_D and Safety Operation Area.

OBSOLETE - PART DISCONTINUED

Electrical Characteristics (@T_A = +25°C, unless otherwise specified.) (Notes 5, 6)

Symbol	Characteristic	Conditions	24°C ± 2°C			-40°C to +125°C			Units
			Min	Typ	Max	Min	Typ	Max	
I _{CC}	Supply Current	28V±0.5% supply	4	4.5	6	2	4.5	7	mA
Output Voltage									
V _{OUT}	#1 Sourcing	Switch magnetically operated: No load 28V±0.5% supply.	6.0	7.0	7.5	-	-	-	V
	#2 Sinking	Switch magnetically released: No load 28V±0.5% supply.	0	0.1	0.2	-	-	-	
	#1 Sinking	Switch magnetically operated: No load 28V±0.5% supply.	0	0.1	0.2	-	-	-	
	#2 Sourcing	Switch magnetically released: No load 28V±0.5% supply.	6.0	7.0	7.5	-	-	-	
I _{Leak(sink)}	Leakage (sink)	Apply voltage 0.2V greater than measured output source voltage measure current, no load 28V±0.5% supply.	-	-	1.0	-	-	1.0	µA
Output Current									
I _{OUT}	#1 Sourcing	Apply 2V to output and measure current. Switch magnetically operated, no load 28V±0.5%.	5.5	7.4	8.0	5.0	7.4	8.5	mA
	#2 Sinking	Apply 2V to output and measure current. Switch magnetically released, no load 28V±0.5%.	2.8	3.4	4.7	2.4	3.4	5.0	
	#1 Sinking	Apply 2V to output and measure current. Switch magnetically operated, no load 28V±0.5%.	2.8	3.4	4.7	2.4	3.4	5.0	
	#2 Sourcing	Apply 2V to output and measure current. Switch magnetically released, no load 28V±0.5%.	5.5	7.4	8.0	5.0	7.4	8.5	
Output Switching Time									
t _f	Fall Time	90% to 10%; no load 28V±0.5% Supply	-	-	-	-	-	1.0	µs
t _r	Rise Time	10% to 90%; no load 28V±0.5% Supply	-	-	-	-	-	1.0	

Magnetic Characteristics

(1mT = 10 Gauss)

Symbol	Characteristic	24°C ± 2°C		-40°C to +125°C		Unit
		V _S = 12V _{DC} ± 0.5%V _{DC}		V _S = 4.5V _{DC} to 28V _{DC}		
		Min	Max	Min	Max	
B _{op}	Operate Point	40	120	30	150	Gauss
B _{rp}	Release Point	-120	-40	-150	-30	Gauss
B _{hy}	Hysteresis	120	200	120	200	Gauss

- Notes:
- All the parameters are tested under the 25°C only. The operation temperature (-40°C to 125°C) is guaranteed by design, it is typical value.
 - The magnetic field strength (gauss) required to cause the switch to change state (operate and release) will be as specified in the magnetic characteristics. To test the switch against the specified magnetic characteristics the switch must be placed in a uniform magnetic field.

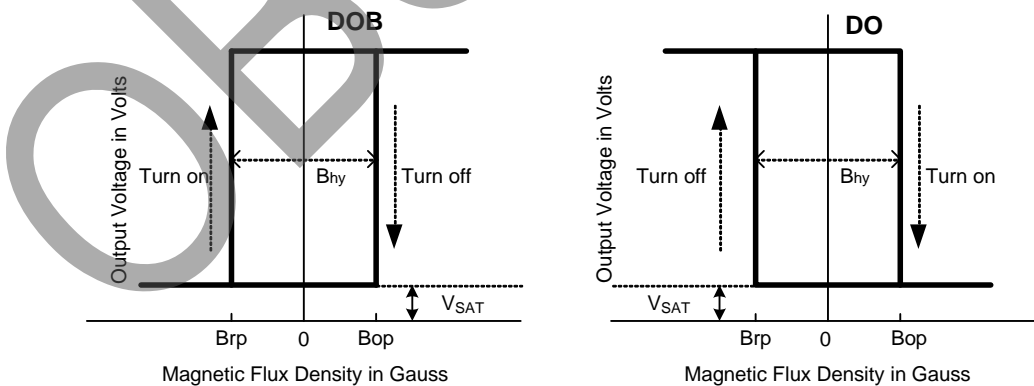

OBSOLETE - PART DISCONTINUED

Operation Characteristics

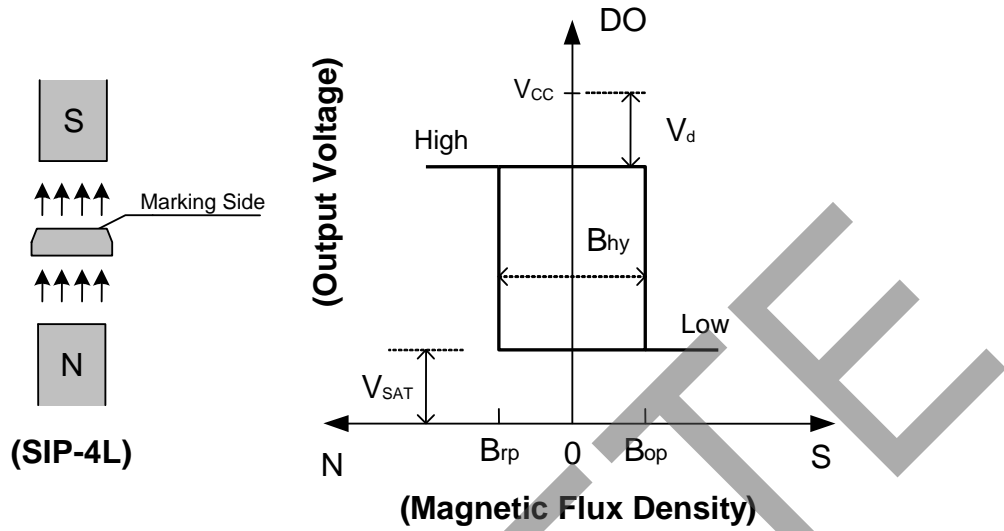

Performance Characteristics

T_A (°C)	25	50	60	70	80	85	90	95	100
P_D (mW)	550	440	396	352	308	286	264	242	220
T_A (°C)	105	110	115	120	125	130	135	140	150
P_D (mW)	198	176	154	132	110	88	66	44	0

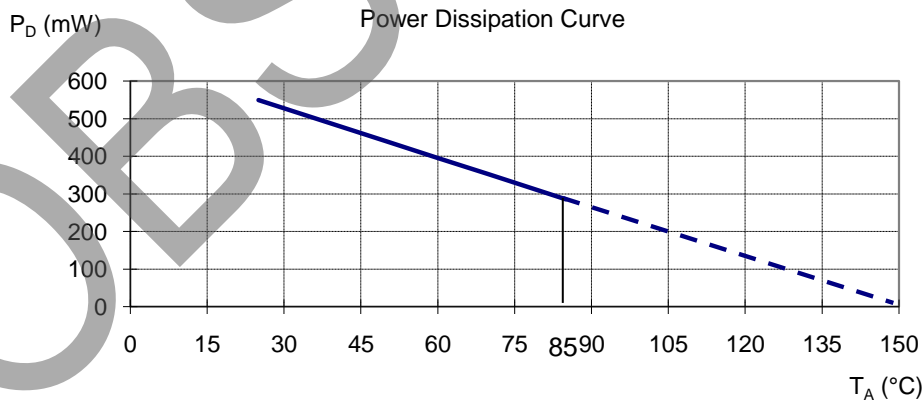

OBSOLETE - PART DISCONTINUED

Ordering Information (Note 7)

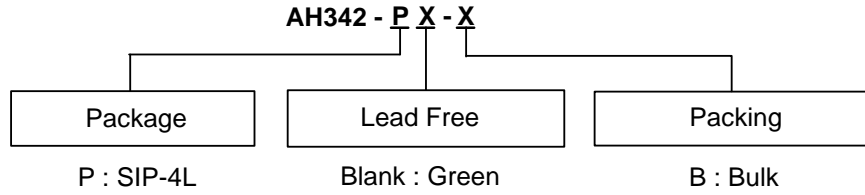

Part Number	Package Code	Packaging	Bulk	
			Quantity	Part Number Suffix
AH342-P-B	P	SIP-4	1000	-B

Note: 7. For packaging details, go to our website at <https://www.diodes.com/design/support/packaging/diodes-packaging/>.

Marking Information

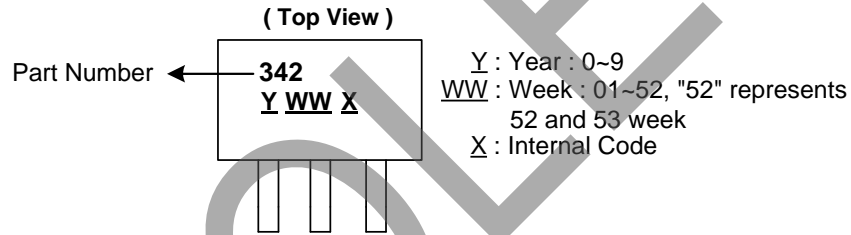

OBSOLETE

Package Outline Dimensions (All dimensions in mm.)

Please see <http://www.diodes.com/package-outlines.html> for the latest version.

(1) Package type: SIP-4L

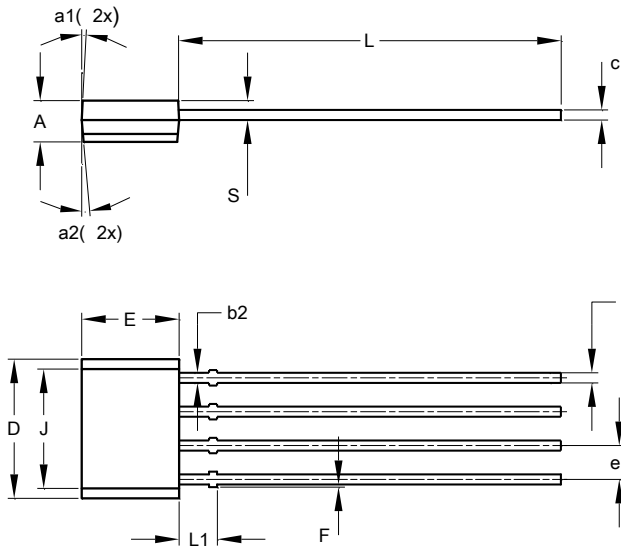

SIP-4L			
Dim	Min	Max	Typ
A	1.45	1.65	1.55
b1	0.38	0.44	0.40
b2	-	-	0.48
c	0.35	0.45	0.40
D	5.12	5.32	5.22
e1	1.24	1.30	1.27
E	3.55	3.75	3.65
F	0.00	0.20	-
J	4.10	4.30	4.20
L	14.00	14.60	14.30
L1	1.32	1.52	1.42
S	0.63	0.83	0.73
a1	-	5°	3°
a2	4°	7°	5°
a3	4°	7°	5°
a4	-	5°	3°

All Dimensions in mm

Min/Max (in mm)

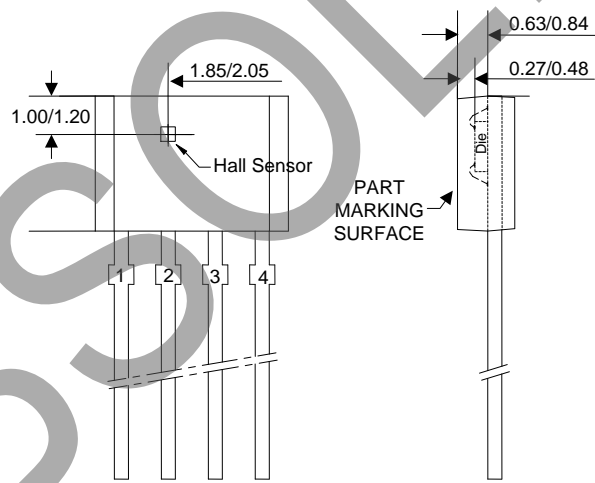

Sensor Location

OBSOLETE - PART DISCONTINUED

OBSOLETE

IMPORTANT NOTICE

DIODES INCORPORATED MAKES NO WARRANTY OF ANY KIND, EXPRESS OR IMPLIED, WITH REGARDS TO THIS DOCUMENT, INCLUDING, BUT NOT LIMITED TO, THE IMPLIED WARRANTIES OF MERCHANTABILITY AND FITNESS FOR A PARTICULAR PURPOSE (AND THEIR EQUIVALENTS UNDER THE LAWS OF ANY JURISDICTION).

Diodes Incorporated and its subsidiaries reserve the right to make modifications, enhancements, improvements, corrections or other changes without further notice to this document and any product described herein. Diodes Incorporated does not assume any liability arising out of the application or use of this document or any product described herein; neither does Diodes Incorporated convey any license under its patent or trademark rights, nor the rights of others. Any Customer or user of this document or products described herein in such applications shall assume all risks of such use and will agree to hold Diodes Incorporated and all the companies whose products are represented on Diodes Incorporated website, harmless against all damages.

Diodes Incorporated does not warrant or accept any liability whatsoever in respect of any products purchased through unauthorized sales channel. Should Customers purchase or use Diodes Incorporated products for any unintended or unauthorized application, Customers shall indemnify and hold Diodes Incorporated and its representatives harmless against all claims, damages, expenses, and attorney fees arising out of, directly or indirectly, any claim of personal injury or death associated with such unintended or unauthorized application.

Products described herein may be covered by one or more United States, international or foreign patents pending. Product names and markings noted herein may also be covered by one or more United States, international or foreign trademarks.

This document is written in English but may be translated into multiple languages for reference. Only the English version of this document is the final and determinative format released by Diodes Incorporated.

LIFE SUPPORT

Diodes Incorporated products are specifically not authorized for use as critical components in life support devices or systems without the express written approval of the Chief Executive Officer of Diodes Incorporated. As used herein:

A. Life support devices or systems are devices or systems which:

1. are intended to implant into the body, or
2. support or sustain life and whose failure to perform when properly used in accordance with instructions for use provided in the labeling can be reasonably expected to result in significant injury to the user.

B. A critical component is any component in a life support device or system whose failure to perform can be reasonably expected to cause the failure of the life support device or to affect its safety or effectiveness.

Customers represent that they have all necessary expertise in the safety and regulatory ramifications of their life support devices or systems, and acknowledge and agree that they are solely responsible for all legal, regulatory and safety-related requirements concerning their products and any use of Diodes Incorporated products in such safety-critical, life support devices or systems, notwithstanding any devices- or systems-related information or support that may be provided by Diodes Incorporated. Further, Customers must fully indemnify Diodes Incorporated and its representatives against any damages arising out of the use of Diodes Incorporated products in such safety-critical, life support devices or systems.

Copyright © 2018, Diodes Incorporated

www.diodes.com

单击下面可查看定价，库存，交付和生命周期等信息

[>>Diodes Incorporated\(达尔科技\)](#)