

Description

The AP43770 is a USB Type-C power delivery controller dedicated to power source applications with legacy capability. It is compliant with USB Type-C specification release 1.3 and USB power delivery (PD) specification Rev3.0 V1.2.

The AP43770 can support PPS APDO with 20mV/step resolution and 50mA/step current resolution for power management. In addition, it supports Qualcomm Quick Charge 4 for mobile market. What's more, cable-loss compensation and SOP⁺ command for e-Marker detection are embedded too.

In consideration of customer applications, the AP43770 supports options for non-PD protocols like BC 1.2, QC4/4+, QC3.0/QC2.0, and other legacy protocols with auto-detection. It maintains backwards compatibility with the existing environment. There are rich power-features embedded on the chip and they can be configured through CC channel.

Pin Assignments

(Top View)

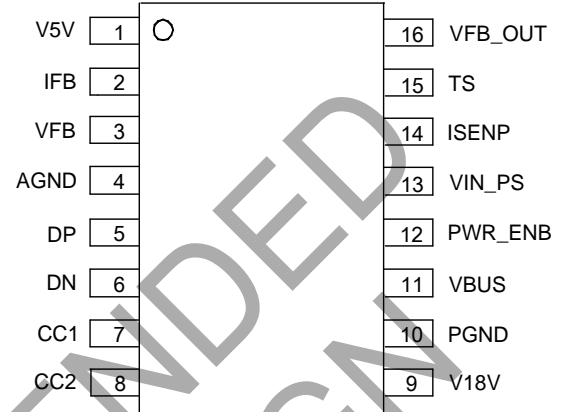

TSSOP-16

Features

- Compliant with USB PD Rev3.0 V1.2
- USB-IF PD3.0/PPS Certificated TID = 1090017
- Qualcomm QC4 and QC4+, QC3.0, QC2.0 Built-in
- Support V_{OUT} 20mV/Step from 3.3V to 20V
- Support Current Limit 50mA/Step up to 6A
- OTP(One-Time-Programmable) for Main Firmware
- MTP (Multi-Time-Programmable) for System Configuration
- USB PD Transceiver with High Noise Immunity
- Built-In CC/CV Controller
- Support e-Marker Cable Detection
- Built-In V_{CONN} Switch with OCP Protection
- Cable Compensation for Different Load Condition
- Programmable for Configuration through CC Line
- Support OCP/SCP/OTP/UVP with Auto-Restart
- Built-In 5V/1.8V LDO
- Low Standby Current : 550 μ A
- Maximum 32V Input Voltage Rating
- Support Non-USB PD Protocol Options
- BC 1.2 Legacy Built-In
- TID(11090017) for USB PD 3.0 PPS Compliance Test
- Package: TSSOP-16
- **Totally Lead-Free & Fully RoHS Compliant (Notes 1 & 2)**
- **Halogen- and Antimony-Free. "Green" Device (Note 3)**

Applications

- AC Adapters
- Car Chargers
- USB PD Converter
- Power Hubs
- Power Banks

Notes: 1. No purposely added lead. Fully EU Directive 2002/95/EC (RoHS), 2011/65/EU (RoHS 2) & 2015/863/EU (RoHS 3) compliant.
 2. See <https://www.diodes.com/quality/lead-free/> for more information about Diodes Incorporated's definitions of Halogen- and Antimony-free, "Green" and Lead-free.
 3. Halogen- and Antimony-free "Green" products are defined as those which contain <900ppm bromine, <900ppm chlorine (<1500ppm total Br + Cl) and <1000ppm antimony compounds.

Functional Block Diagram

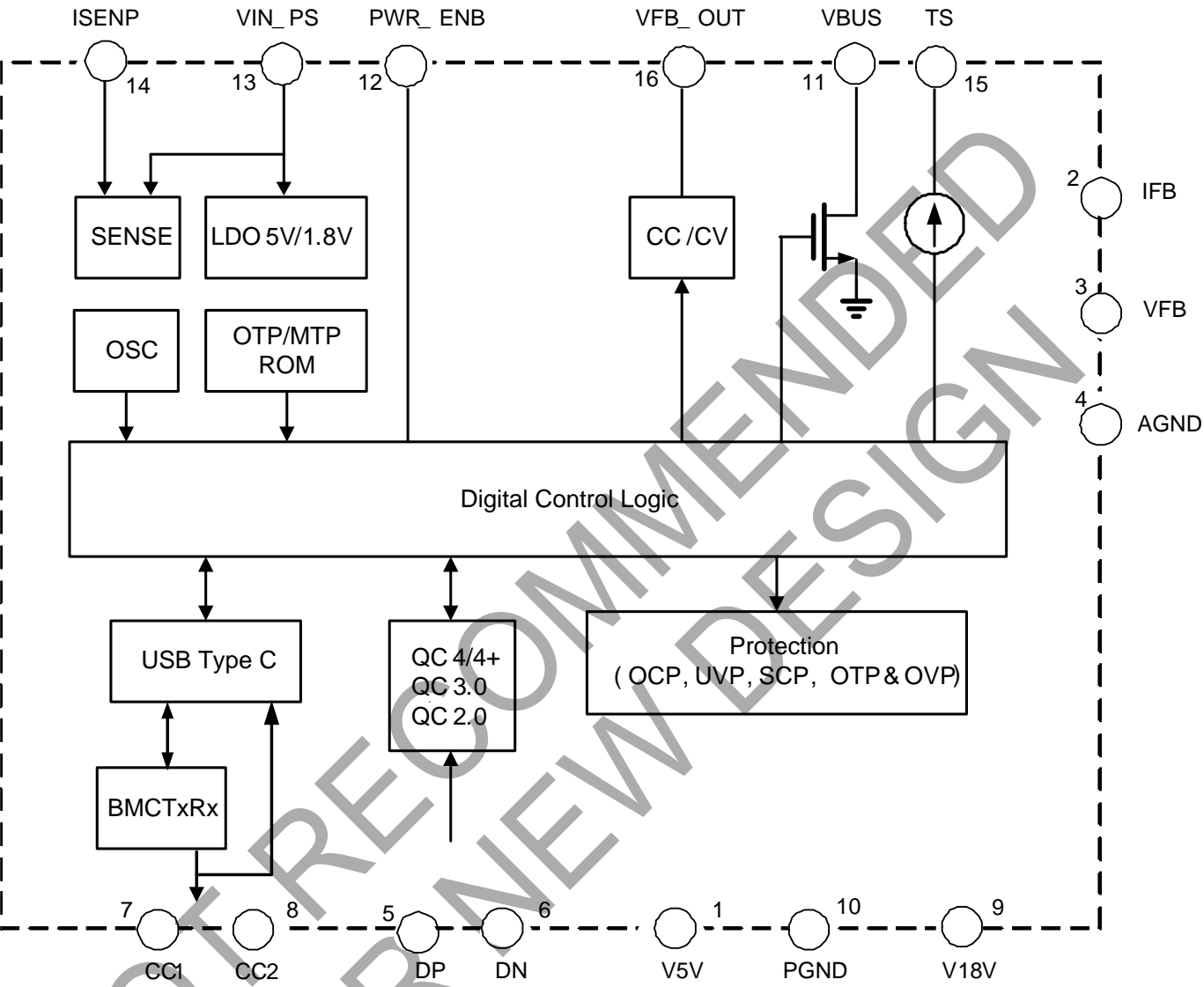

Absolute Maximum Ratings (@ $T_A = +25^\circ\text{C}$, unless otherwise specified.) (Note 4)

Parameter	Rating	Unit
VIN_PS, VBUS, ISEN, PWR_ENB, VFB_OUT, TS Voltage	-0.3 to 32	V
V5V, IFB, VFB, DP, DN, CC1, CC2 Voltage	-0.3 to 7	V
V18V Voltage	-0.3 to 3.6	V
ESD (Human Body Model) Voltage on DP, DN, CC1, CC2 Pins	4	kV
ESD (Human Body Model) Voltage on VIN_PS, VBUS, ISEN, PWR_ENB, VFB_OUT, TS, V5V, IFB, VFB, V18V Pins	2	kV
Maximum Junction-to-Ambient Thermal Resistance	113	$^\circ\text{C}/\text{W}$
Maximum Junction-to-Case Thermal Resistance	34	$^\circ\text{C}/\text{W}$
Operating Junction Temperature Range	-40 to +150	$^\circ\text{C}$
Storage Temperature Range	-40 to +150	$^\circ\text{C}$

Note: 4. Stresses greater than those listed under "Absolute Maximum Ratings" can cause permanent damage to the device. These are stress ratings only, and functional operation of the device at these or any other conditions beyond those indicated under "Recommended Operating Conditions" is not implied. Exposure to "Absolute Maximum Ratings" for extended periods can affect device reliability.

Recommended Operating Conditions (@ $T_A = +25^\circ\text{C}$, unless otherwise specified.)

Symbol	Parameter	Min	Max	Unit
VIN_PS	Power Supply Voltage	0	25	V
TOP	Operating Temperature Range	-40	+85	$^\circ\text{C}$

Electrical Characteristics (@ $T_A = +25^\circ\text{C}$, unless otherwise specified.)

Parameter	Test Conditions	Min	Typ	Max	Unit
UVLO Voltage	VIN_PS Rising	—	2.8	—	V
UVLO Hysteresis Voltage	VIN_PS Falling	—	2.7	—	V
V5V Voltage	VIN_PS = 6V	—	5	—	V
V5V Output Current Limit	—	—	70	—	mA
V18V Voltage	—	—	1.8	—	V
VIN_PS Current in Sleep Mode	CC1/2 Detach after 3s	—	550	—	μA
VIN_PS Current in Normal Mode	VIN_PS = 5V	—	4.5	—	mA
Internal CLK in Normal Mode	—	—	12	—	MHz
VIN_PS_OVP Voltage	—	110	120	130	$\%V_{IN_PS}$
VIN_PS_UVP Voltage	—	—	75	—	$\%V_{IN_PS}$
I _{OCP} Current	I _{MAX} = Setting Maximum Current	—	30	—	$\%I_{MAX}$
OCP Deglitch Time	—	90	—	110	ms
Internal OTP	—	—	+140	—	$^\circ\text{C}$
External OTP Current	—	—	100	—	μA

Performance Characteristics

The AP43770 includes a USB Type-C power delivery controller, which meets USB Power Delivery specification Rev3.0 v1.1. Because of its high voltage process, the AP43770 provides a cost-effective solution without requiring external discrete high voltage components, such as LDO, TL431, CC/CV, pre-driver for external PMOS power switch, buck or boost converter, etc. Meanwhile, it can provide robust protection scheme with built-in OVP/OCP/SCP/OTP features. What's more, it supports on-chip multi-time-programmable (MTP) for maximum four times during the configuration and ID data programming.

In consideration of the quick charge protocol migrating in portable device, the AP43770 supports options for QC4/4+, QC3.0/2.0 and BC 1.2. All of these protocols can be turned on or off and identified automatically. It can be configured with practical applications of users.

System Power-On Sequence

When the external power source is provided, the AP43770 wakes up after the power-on reset ($V_{RST} \sim 2.8V$), then the internal 5V_LDO and 1.8V_LDO are settled, and the USB PD controller and MCU would be initialized. All analog control blocks are ready and waiting for PD negotiation process. Meanwhile, the AP43770 monitors the voltage and current conditions to avoid abnormal conditions. Once any unacceptable conditions happen, the AP43770 goes into protection procedure according to the types of abnormal condition.

Voltage Transition

According to the USB PD's protocol, once the PD device requests different power profiles, the AP43770's power control block starts to change the voltage and current values. The AP43770 provides corresponding Over-Voltage Protection (OVP), Over-Current Protection (OCP) schemes, and maintains the feedback system stability to guarantee monotonic voltage transition and avoid violating the USB PD electrical specification.

The AP43770 provides zero-mismatch voltage methodology which is more flexible for system design requirements of customers. When UFP/DFP makes an acceptable power request deal, the AP43770 changes VFB voltage according to the USB PD command, which is around 1/10 of expected voltage. The voltage regulator control loop (AC/DC or DC/DC) regulates the required V_{BUS} voltage according to V_{FB} voltage. In addition, the shunt regulator is built in to minimize the total external components and the cost.

Protection

The AP43770 supports OVP/UVP/OCP/SCP/OTP and Constant Current (CC) functions. All of the protection thresholds would depend on the requested power profile and provide the most reliable protection scheme.

The AP43770 provides the OVP feature by turning off the power switch when V_{BUS} is 20% higher than the target voltage. Meanwhile, it provides internal discharge path to reduce the overvoltage duration, and terminates discharge current as soon as V_{BUS} reaches the target voltage. To avoid the V_{BUS} working abnormally, the AP43770 provides UVP function if the V_{BUS} is below 75% of the target voltage.

To ensure the USB PD safe operation, the AP43770 supports programmable OCP function to make sure output current would not be higher than the allowed maximum current. Once unacceptable conditions happen, the AP43770 would shut down the USB PD system and send "Hard Reset" to the UFP device.

CV/CC

The AP43770 supports Constant Voltage (CV) and Constant Current (CC) functions. The functions can control the output voltage and current by the control pin VFB_OUT and the feedback pins VFB and IFB. During the CV mode, the AP43770 operates in the fixed PDO, and the output voltage will be regulated to the request voltage if the output current is below the allowed maximum current. Once the sink device draws more than I_{OCP} , overcurrent protection occurs. When the CC mode function is enabled, the output voltage drops, and the source current is limited within 150mA of the requested current whenever output current exceeds the allowed maximum current. When the output voltage drops below UVP, constant current limit turns off V_{BUS} and starts error recovery procedure. The AP43770 will reset if the voltage continues dropping to power-on-reset (POR) threshold.

Performance Characteristics (continued)

Figure 1 and Figure 2 show V/I profile of this CC/CV functions.

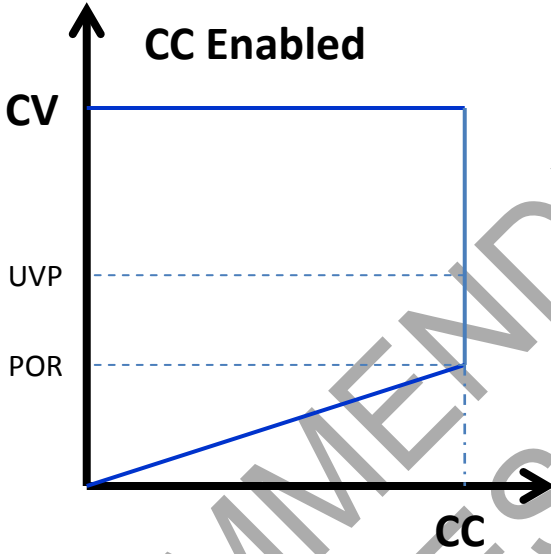

Figure 1. AP43770 V/I Profile When CC Enabled

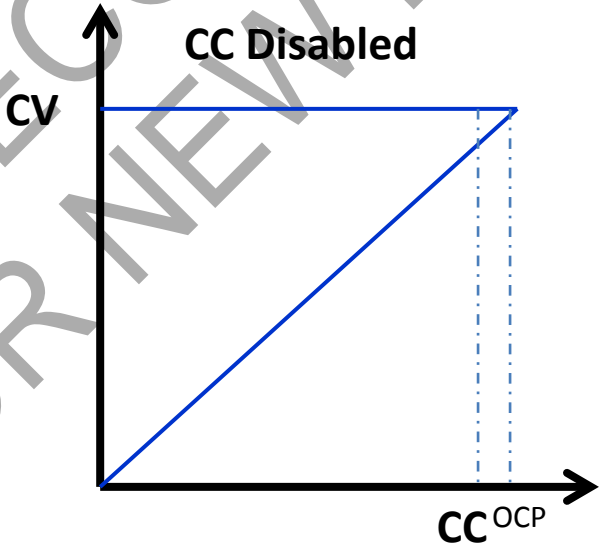
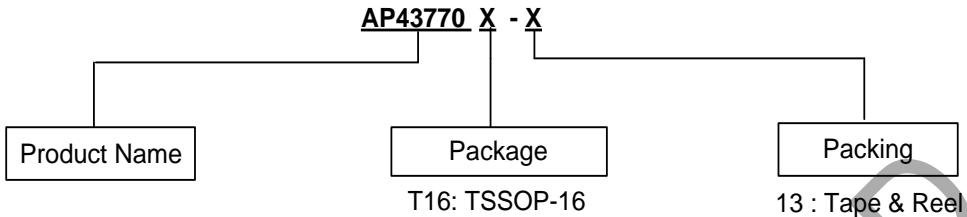

Figure 2. AP43770 V/I Profile When CC Disabled

Ordering Information



Part Number	Package	Marking ID	13" Tape and Reel	
			Quantity	Part Number Suffix
AP43770T16-13	TSSOP-16	AP43770	4000/Tape and Reel	-13

Marking Information

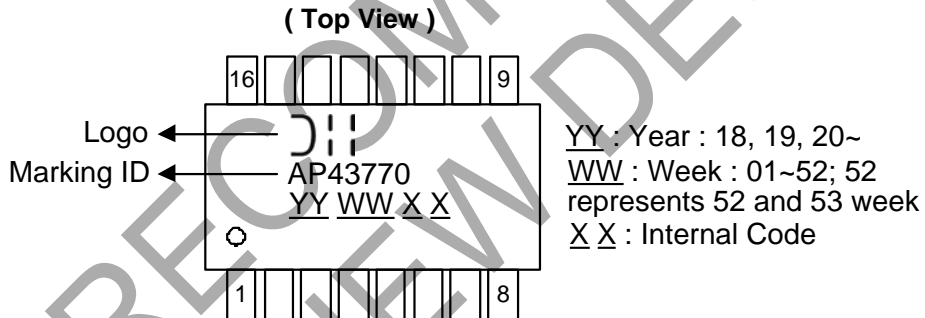

Package Outline Dimensions (All dimensions in mm.)

Please see <http://www.diodes.com/package-outlines.html> for the latest version.

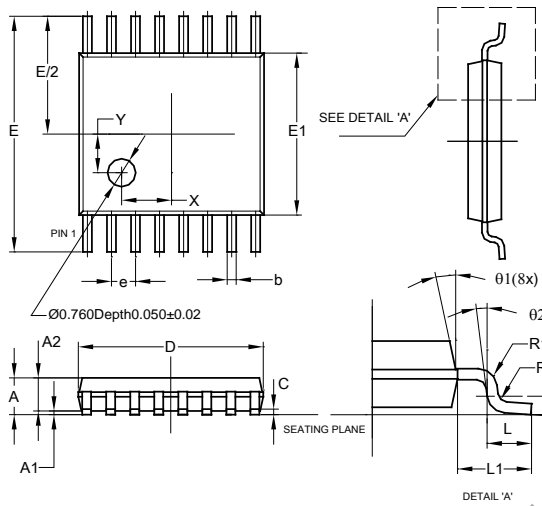

TSSOP-16			
Dim	Min	Max	Typ
A	—	1.20	—
A1	0.05	0.15	—
A2	0.80	1.05	—
b	0.19	0.30	—
c	0.09	0.20	—
D	4.90	5.10	—
E	6.40 BSC		
E1	4.30	4.50	—
e	0.65 BSC		
L	0.45	0.75	—
L1	1.00 REF		
L2	0.25 BSC		
R / R1	0.09	—	—
X	—	—	1.350
Y	—	—	1.050
theta	0°	8°	—
theta1	5°	15°	—
theta2	0°	—	—
All Dimensions in mm			

Suggested Pad Layout

Please see <http://www.diodes.com/package-outlines.html> for the latest version.

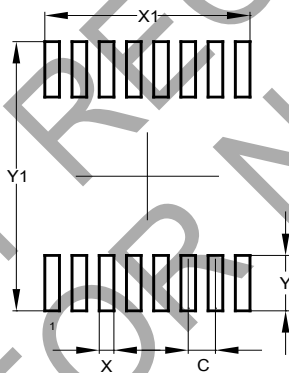

Dimensions	Value (in mm)
C	0.650
X	0.350
X1	4.900
Y	1.400
Y1	6.800

IMPORTANT NOTICE

DIODES INCORPORATED MAKES NO WARRANTY OF ANY KIND, EXPRESS OR IMPLIED, WITH REGARDS TO THIS DOCUMENT, INCLUDING, BUT NOT LIMITED TO, THE IMPLIED WARRANTIES OF MERCHANTABILITY AND FITNESS FOR A PARTICULAR PURPOSE (AND THEIR EQUIVALENTS UNDER THE LAWS OF ANY JURISDICTION).

Diodes Incorporated and its subsidiaries reserve the right to make modifications, enhancements, improvements, corrections or other changes without further notice to this document and any product described herein. Diodes Incorporated does not assume any liability arising out of the application or use of this document or any product described herein; neither does Diodes Incorporated convey any license under its patent or trademark rights, nor the rights of others. Any Customer or user of this document or products described herein in such applications shall assume all risks of such use and will agree to hold Diodes Incorporated and all the companies whose products are represented on Diodes Incorporated website, harmless against all damages.

Diodes Incorporated does not warrant or accept any liability whatsoever in respect of any products purchased through unauthorized sales channel. Should Customers purchase or use Diodes Incorporated products for any unintended or unauthorized application, Customers shall indemnify and hold Diodes Incorporated and its representatives harmless against all claims, damages, expenses, and attorney fees arising out of, directly or indirectly, any claim of personal injury or death associated with such unintended or unauthorized application.

Products described herein may be covered by one or more United States, international or foreign patents pending. Product names and markings noted herein may also be covered by one or more United States, international or foreign trademarks.

This document is written in English but may be translated into multiple languages for reference. Only the English version of this document is the final and determinative format released by Diodes Incorporated.

LIFE SUPPORT

Diodes Incorporated products are specifically not authorized for use as critical components in life support devices or systems without the express written approval of the Chief Executive Officer of Diodes Incorporated. As used herein:

A. Life support devices or systems are devices or systems which:

1. are intended to implant into the body, or
2. support or sustain life and whose failure to perform when properly used in accordance with instructions for use provided in the labeling can be reasonably expected to result in significant injury to the user.

B. A critical component is any component in a life support device or system whose failure to perform can be reasonably expected to cause the failure of the life support device or to affect its safety or effectiveness.

Customers represent that they have all necessary expertise in the safety and regulatory ramifications of their life support devices or systems, and acknowledge and agree that they are solely responsible for all legal, regulatory and safety-related requirements concerning their products and any use of Diodes Incorporated products in such safety-critical, life support devices or systems, notwithstanding any devices- or systems-related information or support that may be provided by Diodes Incorporated. Further, Customers must fully indemnify Diodes Incorporated and its representatives against any damages arising out of the use of Diodes Incorporated products in such safety-critical, life support devices or systems.

Copyright © 2020, Diodes Incorporated

www.diodes.com

单击下面可查看定价，库存，交付和生命周期等信息

[>>Diodes Incorporated\(达达科技\(美台\)\)](#)