

Description

The ZXGD3104 is intended to drive MOSFETs configured as ideal diode replacements. The device is comprised of a differential amplifier detector stage and high current driver. The detector monitors the reverse voltage of the MOSFET, such that if the body diode conduction occurs, a positive voltage is applied to the MOSFET's Gate Pin.

Once the positive voltage is applied to the Gate, the MOSFET switches on. The detector's output voltage is then proportional to the MOSFET Drain-Source voltage, and this is applied to the Gate via the driver. This action provides a rapid MOSFET turn-off at zero Drain current.

Applications

- Flyback Converters in:
 - ≥90W Laptop Adaptors

Features

- 5-25V V_{CC} Range
- Operating up to 250kHz
- Suitable for Discontinuous Conduction Mode (DCM), Critical Conduction Mode (CrCM), and Continuous Conduction Mode (CCM) Operation
- Turn-Off Propagation Delay 15ns and Turn-Off Time 20ns
- Proportional Gate Drive Control
- Detector Threshold Voltage -10mV
- Standby Current 5mA
- Totally Lead-Free & Fully RoHS Compliant (Notes 1 & 2)**
- Halogen and Antimony Free. "Green" Device (Note 3)**
- Qualified to AEC-Q101 Standards for High Reliability**

Mechanical Data

- Case: SO-8
- Case material: Molded Plastic. "Green" Molding Compound. UL Flammability Rating 94V-0
- Moisture Sensitivity: Level 1 per J-STD-020
- Terminals: Matte Tin Finish – Solderable per MIL-STD-202, Method 208 (E3)
- Weight: 0.074 grams (Approximate)

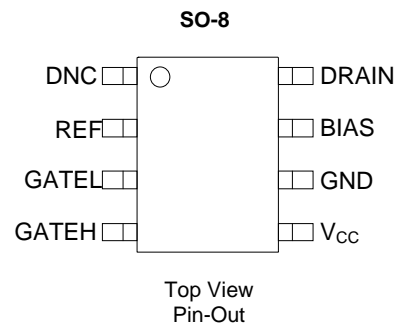
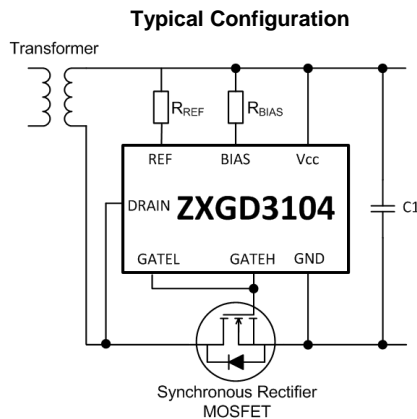

Ordering Information (Note 4)

Product	Marking	Reel Size (inches)	Tape Width (mm)	Quantity per Reel
ZXGD3104N8TC	ZXGD3104	13	12	2,500

- Notes:
- No purposely added lead. Fully EU Directive 2002/95/EC (RoHS) & 2011/65/EU (RoHS 2) compliant.
 - See http://www.diodes.com/quality/lead_free.html for more information about Diodes Incorporated's definitions of Halogen- and Antimony-free, "Green" and Lead-free.
 - Halogen- and Antimony-free "Green" products are defined as those which contain <900ppm bromine, <900ppm chlorine, <1500ppm total Br + Cl) and <1000ppm antimony compounds.
 - For packaging details, go to our website at <http://www.diodes.com/products/packages.html>.

Marking Information

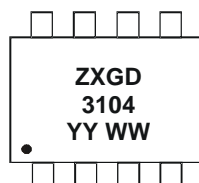

- ZXGD = Product Type Marking Code, Line 1
- 3104 = Product Type Marking Code, Line 2
- YY = Year (ex: 11 = 2011)
- WW = Week (01 - 53)

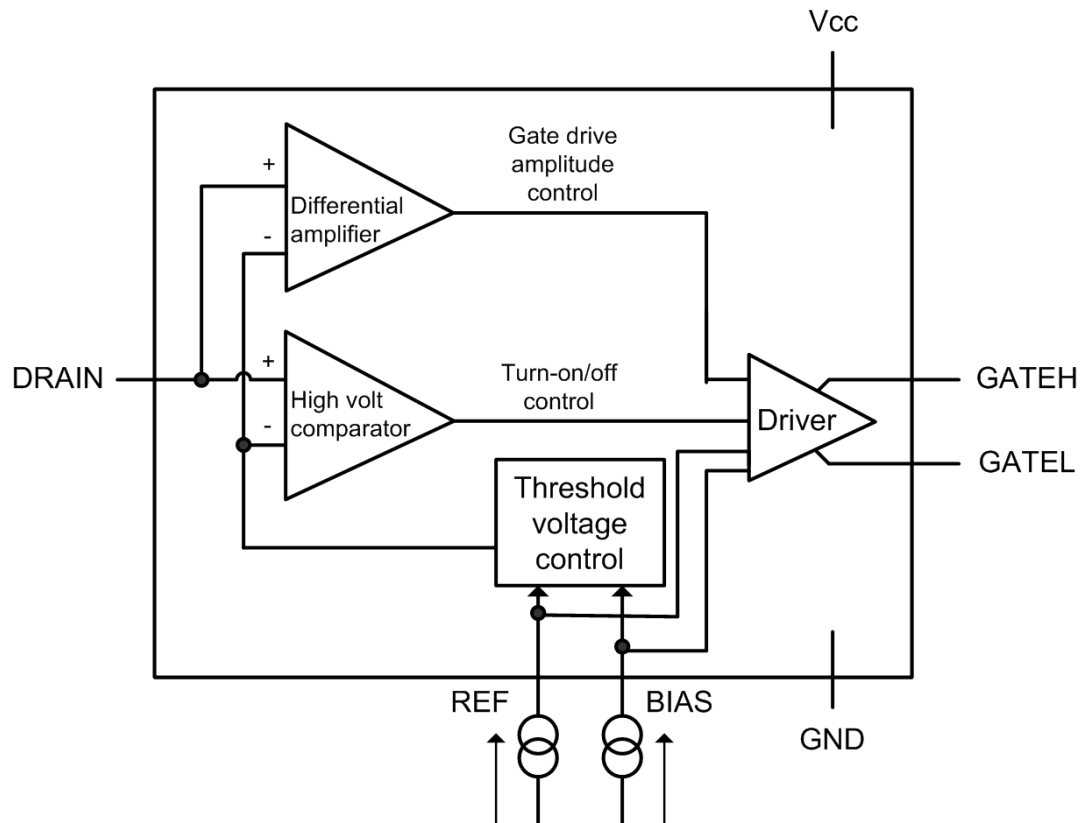
Functional Block Diagram

Pin Number	Name	Description and Function
1	DNC	Do Not Connect Leave pin floating.
2	REF	Reference This pin is connected to V_{CC} via resistor, R_{REF} . Select R_{REF} to source 2.16mA into this pin. Refer to Table 1 in Application Information section.
3	GATEL	Gate Turn-Off This pin sinks current, I_{SINK} , from the synchronous MOSFET Gate.
4	GATEH	Gate Turn-On This pin sources current, I_{SOURCE} , to the synchronous MOSFET Gate.
5	V_{CC}	Power Supply This is the supply pin. It is recommended to decouple this point to Ground closely with a ceramic capacitor.
6	GND	Ground This is the ground reference point. Connect to the synchronous MOSFET Source terminal.
7	BIAS	Bias This pin is connected to V_{CC} via resistor, R_{BIAS} . Select R_{BIAS} to Source 3mA into this pin. Refer to Table 1 in Application Information section.
8	DRAIN	Drain Connection This pin connects directly to the synchronous MOSFET Drain terminal.

Maximum Ratings (@T_A = +25°C, unless otherwise specified.)

Characteristic	Symbol	Value	Unit
Supply Voltage, Relative to GND	V _{CC}	25	V
Drain Pin Voltage	V _D	-3 to 180	V
Gate Output Voltage	V _G	-3 to V _{CC} +3	V
Gate Driver Peak Source Current	I _{SOURCE}	2.5	A
Gate Driver Peak Sink Current	I _{SINK}	7	A
Reference Voltage	V _{REF}	V _{CC}	V
Reference Current	I _{REF}	25	mA
Bias Voltage	V _{BIAS}	V _{CC}	V
Bias Current	I _{BIAS}	100	mA

Thermal Characteristics (@T_A = +25°C, unless otherwise specified.)

Characteristic	Symbol	Value	Unit	
Power Dissipation Linear Derating Factor	P _D	(Note 5)	490	mW mW/°C
		(Note 6)	3.92	
		(Note 7)	655	
		(Note 8)	5.24	
		(Note 8)	720	
Thermal Resistance, Junction to Ambient	R _{θJA}	(Note 5)	5.76	°C/W
		(Note 6)	785	
		(Note 7)	6.28	
		(Note 8)	255	
Thermal Resistance, Junction to Lead	R _{θJL}	135	°C/W	
Operating Temperature Range	T _J	-40 to +150	°C	
Storage Temperature Range	T _{STG}	-55 to +150		

- Notes:
5. For a device surface mounted on minimum recommended pad layout FR4 PCB with high coverage of single sided 1oz copper, in still air conditions; the device is measured when operating in a steady-state condition.
 6. Same as Note (5), except Pin 5 (V_{CC}) and Pin 6 (GND) are both connected to separate 5mm x 5mm 1oz copper heatsinks.
 7. Same as Note (6), except both heatsinks are 10mm x 10mm.
 8. Same as Note (6), except both heatsinks are 15mm x 15mm.
 9. Thermal resistance from junction to solder-point at the end of each lead on Pin 5 (V_{CC}) and Pin 6 (GND).

Thermal Derating Curve

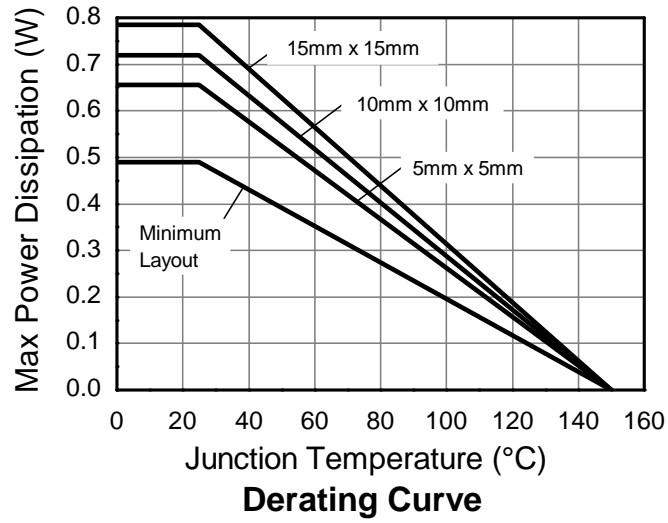

ESD Rating

Characteristic	Value	Unit
ESD for Human Body Model	2,000	V
ESD for Machine Model	300	

Electrical Characteristics (@ $T_A = +25^\circ\text{C}$, unless otherwise specified.)

 $V_{CC} = 19\text{V}$; $R_{BIAS} = 6.3\text{k}\Omega$; $R_{REF} = 8.5\text{k}\Omega$

Characteristic	Symbol	Min	Typ	Max	Unit	Test Condition	
Input and Supply							
Quiescent Current	I_Q	—	5.16	—	mA	$V_D \geq 0\text{V}$	
Gate Driver							
Turn-Off Threshold Voltage (Notes 10 & 11)	V_T	-16	-10	0	mV	$V_G = 1\text{V}$	
Gate Output Voltage	(Notes 10 & 11)	$V_{G(off)}$	0	0.73	1.0	V	$V_D \geq 1\text{V}$
	(Notes 10 & 12)	V_G	12.5	14	V_{CC}		$V_D = -50\text{mV}$
			17	18	V_{CC}		$V_D = -100\text{mV}$
Switching Performance for $Q_{G(tot)} = 124\text{nC}$ (Note 13)							
Turn-On Propagation Delay	$t_{d(rise)}$	175	250	325	ns	— Refer to Switching Waveforms in Fig. 1	
Turn-Off Propagation Delay	$t_{d(fall)}$	11	15	20			
Gate Rise Time	t_r	335	480	625			
		530	760	990			
Gate Fall Time	t_f	35	50	65	Continuous Conduction Mode		

Notes:

10. GATEH connected to GATEL
11. $R_H = 100\text{k}\Omega$, $R_L = \text{O/C}$
12. $R_L = 100\text{k}\Omega$, $R_H = \text{O/C}$
13. Refer to test circuit below.

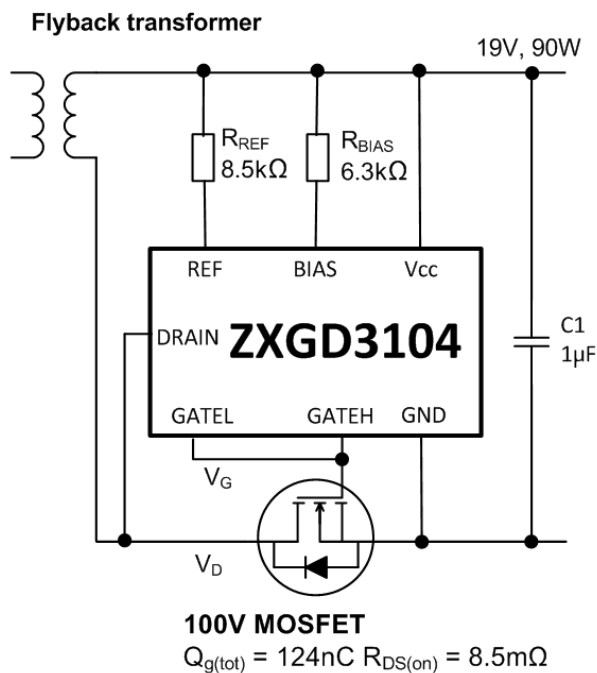
Test Circuit

Test conditions

Primary side input voltage = 400V
 Switching frequency = 65kHz
 Discontinuous conduction mode

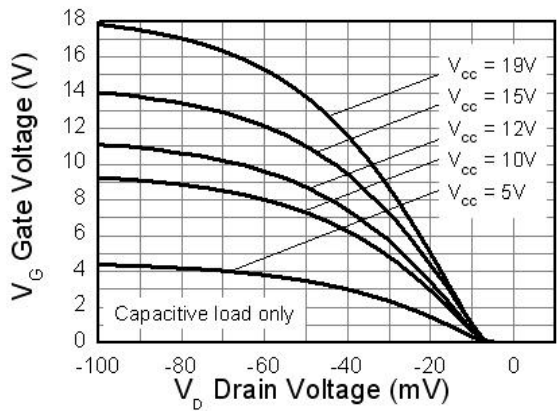
Typical Electrical Characteristics (@T_A = +25°C, unless otherwise specified.)

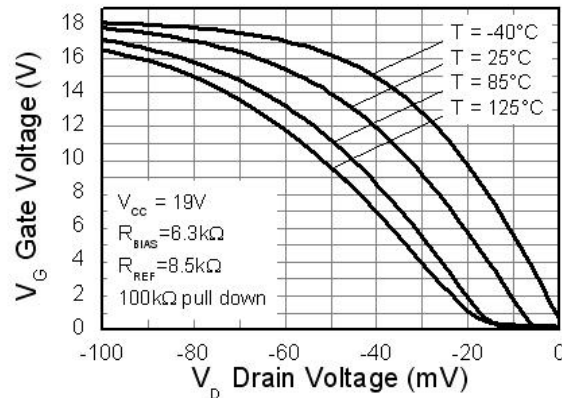

Transfer Characteristic



Transfer Characteristic

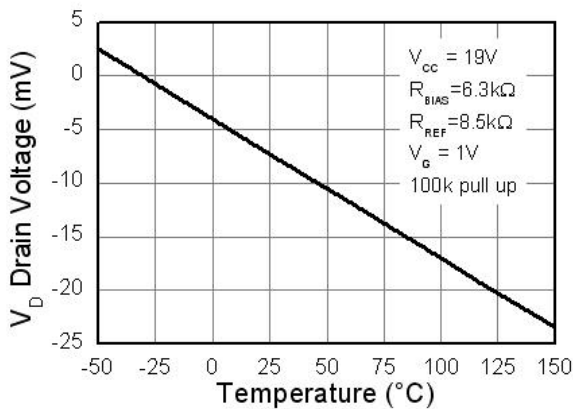

Drain Sense Voltage vs Temperature

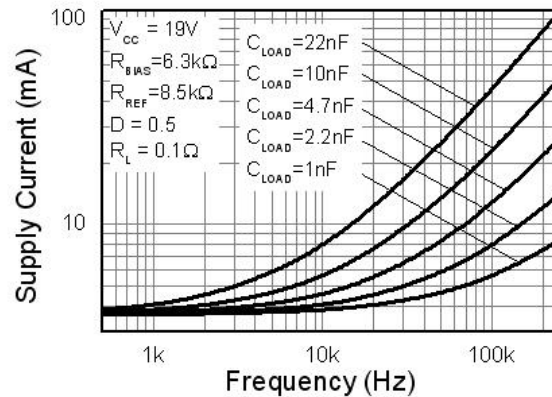

Supply Current vs Frequency

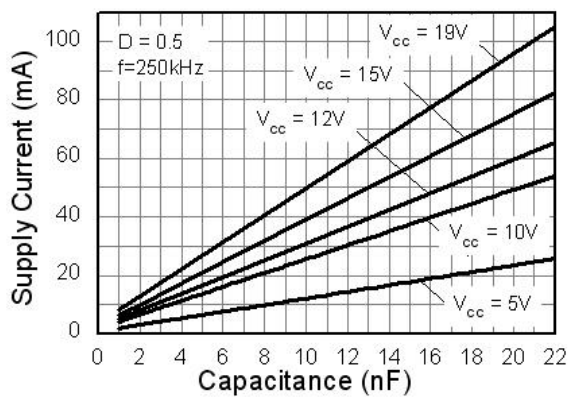

Supply Current vs Capacitive Load

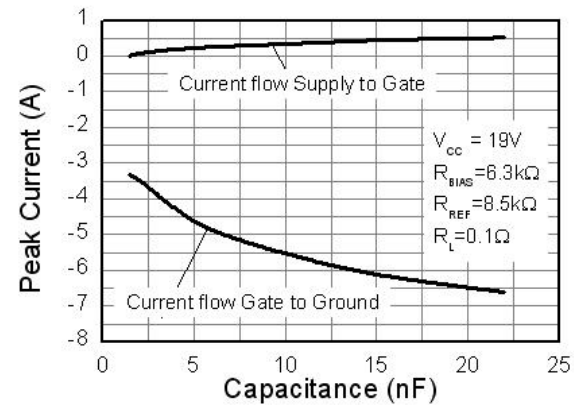

Gate Current vs Capacitive Load

Typical Electrical Characteristics (Continued) (@ $T_A = +25^\circ\text{C}$, unless otherwise specified.)

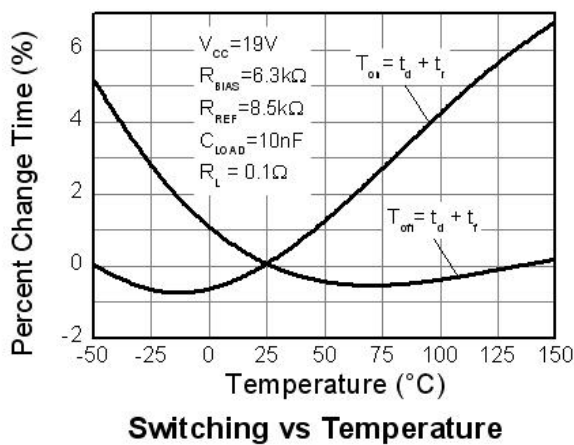
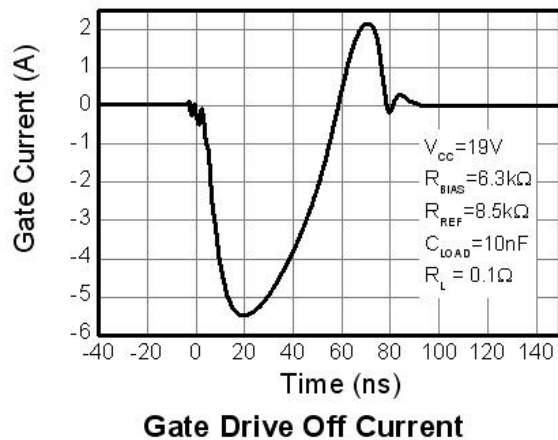
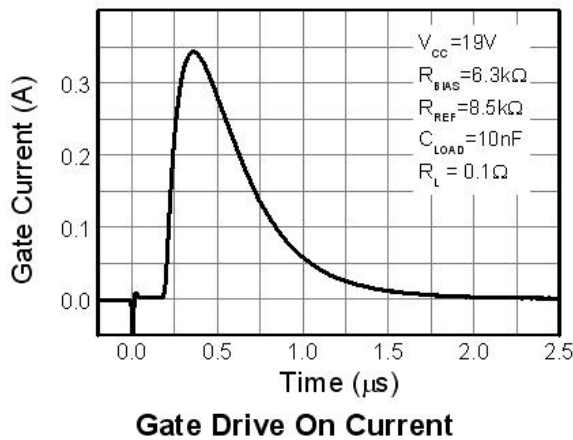
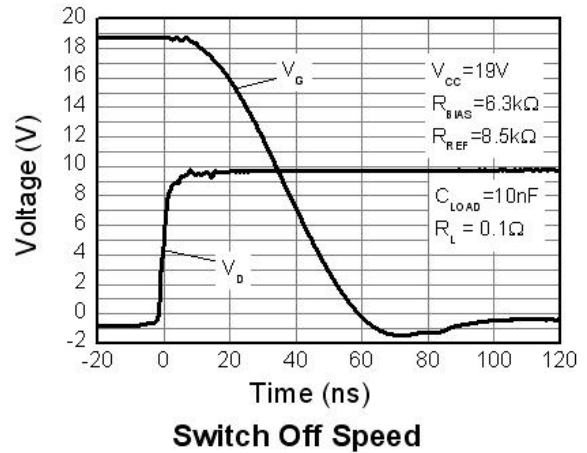
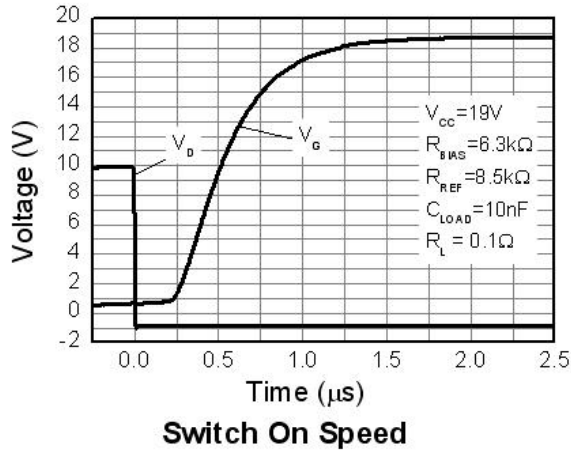

Application Information

Descriptions of the Normal Operation

The operation of the controller is described step-by-step with reference to the timing diagram in Figure 1.

1. The controller monitors the MOSFET Drain-Source voltage.
2. When the MOSFET body diode is forced to conduct, due to transformer action, there is approximately -0.8V on the Drain Pin.
3. The detector outputs a positive voltage with respect to Ground, this voltage is then fed to the MOSFET driver stage and current is sourced out of the Gate Pin.
4. The controller goes into proportional gate drive control – the Gate output voltage is proportional to the on-resistance-induced Drain-Source voltage drop across the MOSFET. Proportional gate drive ensures that MOSFET conducts for majority of the conduction cycle and minimizes body diode conduction time.
5. As the Drain current decays linearly toward zero, proportional gate drive control reduces the Gate voltage so the MOSFET can be turned off rapidly at zero current crossing. The Gate voltage is removed when the Drain-Source voltage crosses the detection threshold voltage to minimize reverse current flow.
6. At zero Drain current, the controller Gate output voltage is pulled low to $V_{G(off)}$ to ensure that the MOSFET is turned off.

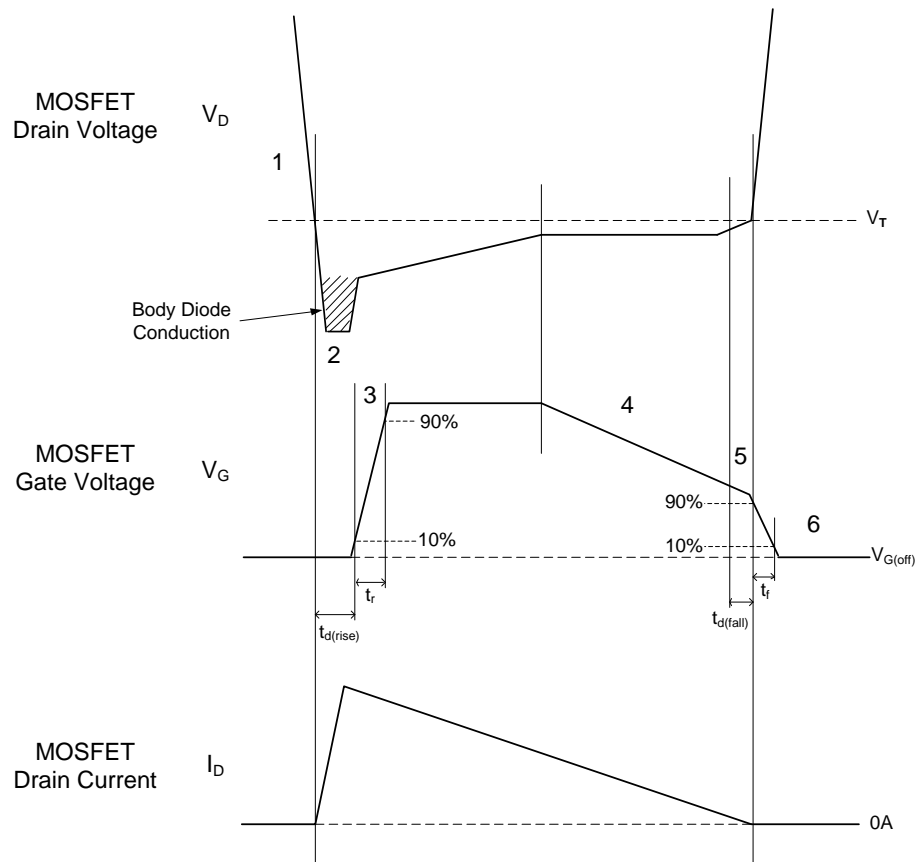

Figure 1: Timing Diagram for a Critical Conduction Mode Flyback Converter

Application Information (Continued)

The purpose of the ZXGD3104 is to drive a MOSFET as a low V_F Schottky diode replacement in offline power converters. When combined with a low $R_{DS(ON)}$ MOSFET, it can yield significant power efficiency improvement, while maintaining design simplicity and incurring minimal component count. Figure 2 shows the typical configuration of ZXGD3104 for synchronous rectification in a 19V output flyback adaptor.

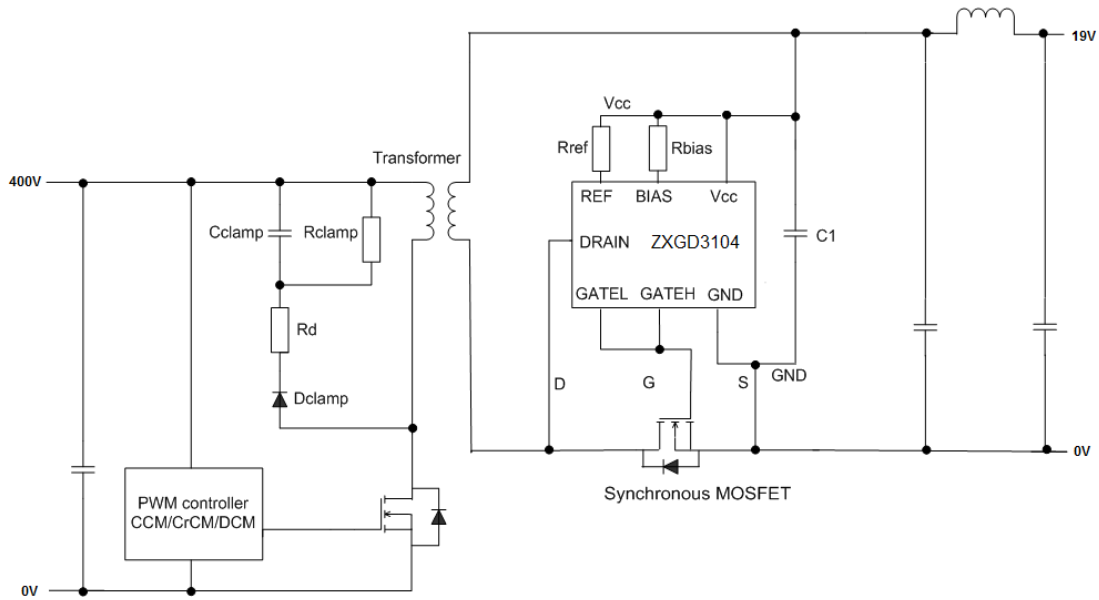

Figure 2: Example Connections in Flyback Power Supply

Application Information (Cont.)

Figure 3 shows operating waveforms for ZXGD3104 driving a MOSFET with $Q_{g(TOT)} = 124nC$ in a 19V output flyback converter operating in critical conduction mode.

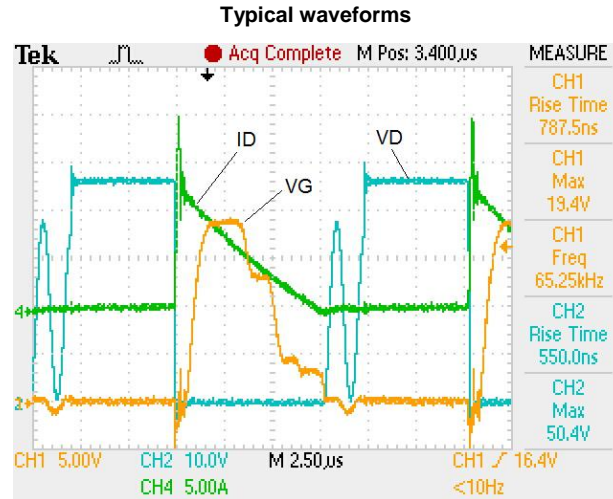

Fig 3a: Critical Conduction Mode, Operating for MOSFET with $Q_{g(TOT)} = 124nC$

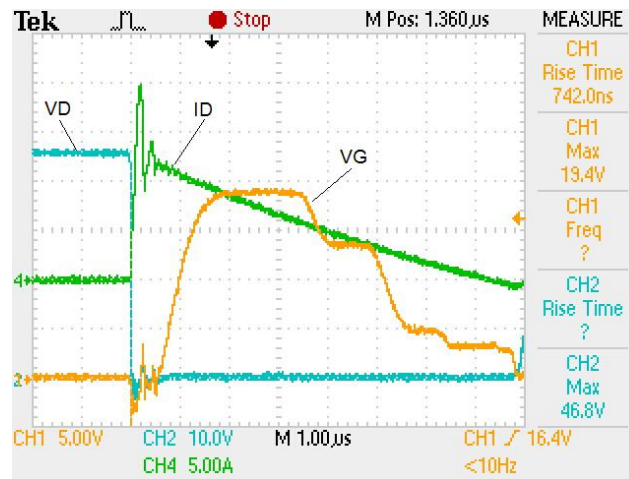

Fig 3b: Typical Switching Waveform

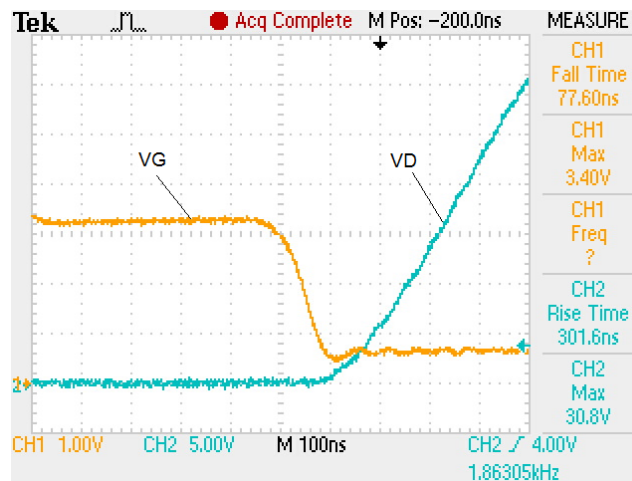

Figure 3c: Close-Up of Typical Turn-Off Waveform

Application Information (Cont.)

Design Considerations

It is advisable to decouple the ZXGD3104 closely to V_{CC} and ground due to the possibility of high peak gate currents with a $1\mu\text{F}$ X7R type ceramic capacitor C1 as shown in Figure 2. Also the Ground return loop should be as short as possible.

To minimize parasitic inductance-induced premature turn-off of the synchronous controller, always keep the PCB track length between ZXGD3104's Drain input and the MOSFET's Drain to less than 10mm. Low internal inductance SMD MOSFET packages are also recommended for high switching frequency power conversion to minimize MOSFET body diode conduction loss.

The Gate Pins should be as close to the MOSFET's gate as possible. External gate resistors are optional. They can be inserted to control the rise and fall time which may help with EMI issues.

The careful selection of external resistors R_{REF} and R_{BIAS} is important to the optimum device operation. Select a value for resistor R_{REF} and R_{BIAS} from Table 1 based on the desired V_{CC} value. This provides the typical ZXGD3104's detection threshold voltage of -10mV.

Table 1: Recommended Resistor Values for Various Supply Voltages

V_{CC}	R_{BIAS}	R_{REF}
5V	1.6k Ω	2k Ω
10V	3.3k Ω	4.3k Ω
12V	3.9k Ω	5.1k Ω
15V	5.1k Ω	6.8k Ω
19V	6.3k Ω	8.5k Ω

Package Outline Dimensions

Please see AP02001 at <http://www.diodes.com/datasheets/ap02001.pdf> for the latest version.

SO-8

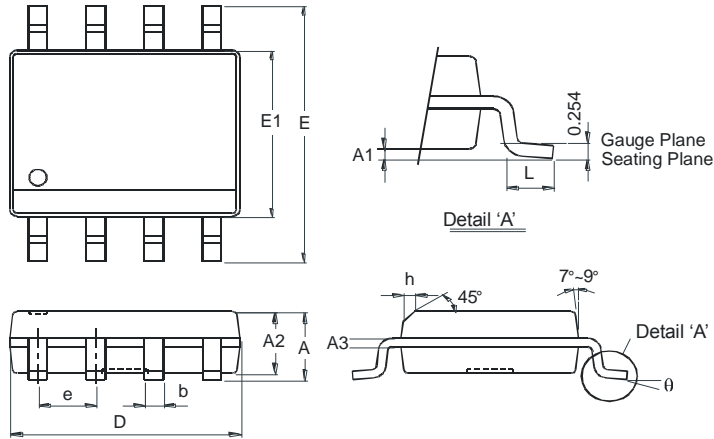

SO-8		
Dim	Min	Max
A	-	1.75
A1	0.10	0.20
A2	1.30	1.50
A3	0.15	0.25
b	0.3	0.5
D	4.85	4.95
E	5.90	6.10
E1	3.85	3.95
e	1.27 Typ	
h	-	0.35
L	0.62	0.82
θ	0°	8°
All Dimensions in mm		

Suggested Pad Layout

Please see AP02001 at <http://www.diodes.com/datasheets/ap02001.pdf> for the latest version.

SO-8

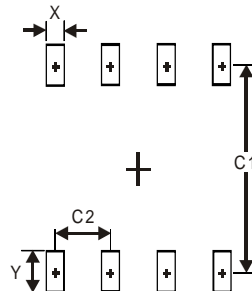

Dimensions	Value (in mm)
X	0.60
Y	1.55
C1	5.4
C2	1.27

Note: For high voltage applications, the appropriate industry sector guidelines should be considered with regards to creepage and clearance distances between device Terminals and PCB tracking.

IMPORTANT NOTICE

DIODES INCORPORATED MAKES NO WARRANTY OF ANY KIND, EXPRESS OR IMPLIED, WITH REGARDS TO THIS DOCUMENT, INCLUDING, BUT NOT LIMITED TO, THE IMPLIED WARRANTIES OF MERCHANTABILITY AND FITNESS FOR A PARTICULAR PURPOSE (AND THEIR EQUIVALENTS UNDER THE LAWS OF ANY JURISDICTION).

Diodes Incorporated and its subsidiaries reserve the right to make modifications, enhancements, improvements, corrections or other changes without further notice to this document and any product described herein. Diodes Incorporated does not assume any liability arising out of the application or use of this document or any product described herein; neither does Diodes Incorporated convey any license under its patent or trademark rights, nor the rights of others. Any Customer or user of this document or products described herein in such applications shall assume all risks of such use and will agree to hold Diodes Incorporated and all the companies whose products are represented on Diodes Incorporated website, harmless against all damages.

Diodes Incorporated does not warrant or accept any liability whatsoever in respect of any products purchased through unauthorized sales channel. Should Customers purchase or use Diodes Incorporated products for any unintended or unauthorized application, Customers shall indemnify and hold Diodes Incorporated and its representatives harmless against all claims, damages, expenses, and attorney fees arising out of, directly or indirectly, any claim of personal injury or death associated with such unintended or unauthorized application.

Products described herein may be covered by one or more United States, international or foreign patents pending. Product names and markings noted herein may also be covered by one or more United States, international or foreign trademarks.

This document is written in English but may be translated into multiple languages for reference. Only the English version of this document is the final and determinative format released by Diodes Incorporated.

LIFE SUPPORT

Diodes Incorporated products are specifically not authorized for use as critical components in life support devices or systems without the express written approval of the Chief Executive Officer of Diodes Incorporated. As used herein:

A. Life support devices or systems are devices or systems which:

1. are intended to implant into the body, or
2. support or sustain life and whose failure to perform when properly used in accordance with instructions for use provided in the labeling can be reasonably expected to result in significant injury to the user.

B. A critical component is any component in a life support device or system whose failure to perform can be reasonably expected to cause the failure of the life support device or to affect its safety or effectiveness.

Customers represent that they have all necessary expertise in the safety and regulatory ramifications of their life support devices or systems, and acknowledge and agree that they are solely responsible for all legal, regulatory and safety-related requirements concerning their products and any use of Diodes Incorporated products in such safety-critical, life support devices or systems, notwithstanding any devices- or systems-related information or support that may be provided by Diodes Incorporated. Further, Customers must fully indemnify Diodes Incorporated and its representatives against any damages arising out of the use of Diodes Incorporated products in such safety-critical, life support devices or systems.

Copyright © 2015, Diodes Incorporated

www.diodes.com

单击下面可查看定价，库存，交付和生命周期等信息

[>>Diodes Incorporated\(达尔科技\)](#)