

Description

The AP2126 series are positive voltage regulator ICs fabricated by CMOS process.

The AP2126 series have features of low dropout voltage, low noise, high output voltage accuracy, and low current consumption which make them ideal for use in various battery-powered devices.

The AP2126 is available in 1.25V to 5.5V adjustable voltage versions.

The AP2126 series are available in SOT-23-5 Package.

Features

- Wide Operating Voltage: 3.0V to 6V
- High Output Voltage Accuracy: $\pm 2\%$
- High Ripple Rejection: 68dB@ f = 1kHz, 54dB@ f = 10kHz
- Low Standby Current: 0.1 μ A
- Low Dropout Voltage: 170mV@300mA for $V_{OUT} = 3.3V$, 140mV@ 300mA for $V_{OUT} = 5.2V$
- Low Quiescent Current: 60 μ A Typical
- Low Output Noise: 80 μ Vrms@ $V_{OUT} = 1.25V$
- Short Current Limit: 50mA
- Over Temperature Protection
- Compatible with Low ESR Ceramic Capacitor: 1 μ F for C_{IN} and C_{OUT}
- Excellent Line/Load Regulation
- Soft Start Time: 50 μ s
- Auto Discharge Resistance: $R_{DS(ON)} = 60\Omega$
- **Totally Lead-free & Fully RoHS Compliant (Notes 1 & 2)**
- **Halogen & Antimony Free. "Green" Device (Note 3)**

- Notes:
1. No purposely added lead. Fully EU Directive 2002/95/EC (RoHS) & 2011/65/EU (RoHS 2) compliant.
 2. See http://www.diodes.com/quality/lead_free.html for more information about Diodes Incorporated's definitions of Halogen- and Antimony-free, "Green" and Lead-free.
 3. Halogen- and Antimony-free "Green" products are defined as those which contain <900ppm bromine, <900ppm chlorine (<1500ppm total Br + Cl) and <1000ppm antimony compounds.

Pin Assignments

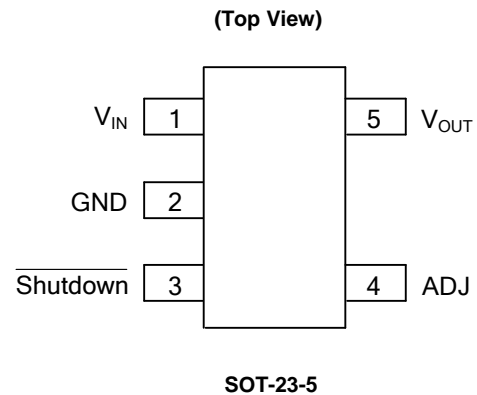

Applications

- Datacom
- Notebook Computers
- Mother Board

Typical Applications Circuit

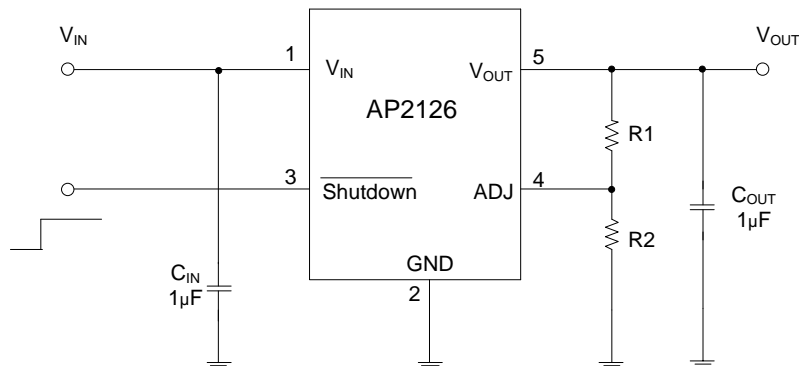

$$V_{OUT} = 1.25 \cdot (1 + R1/R2) \text{ V}$$

Functional Block Diagram

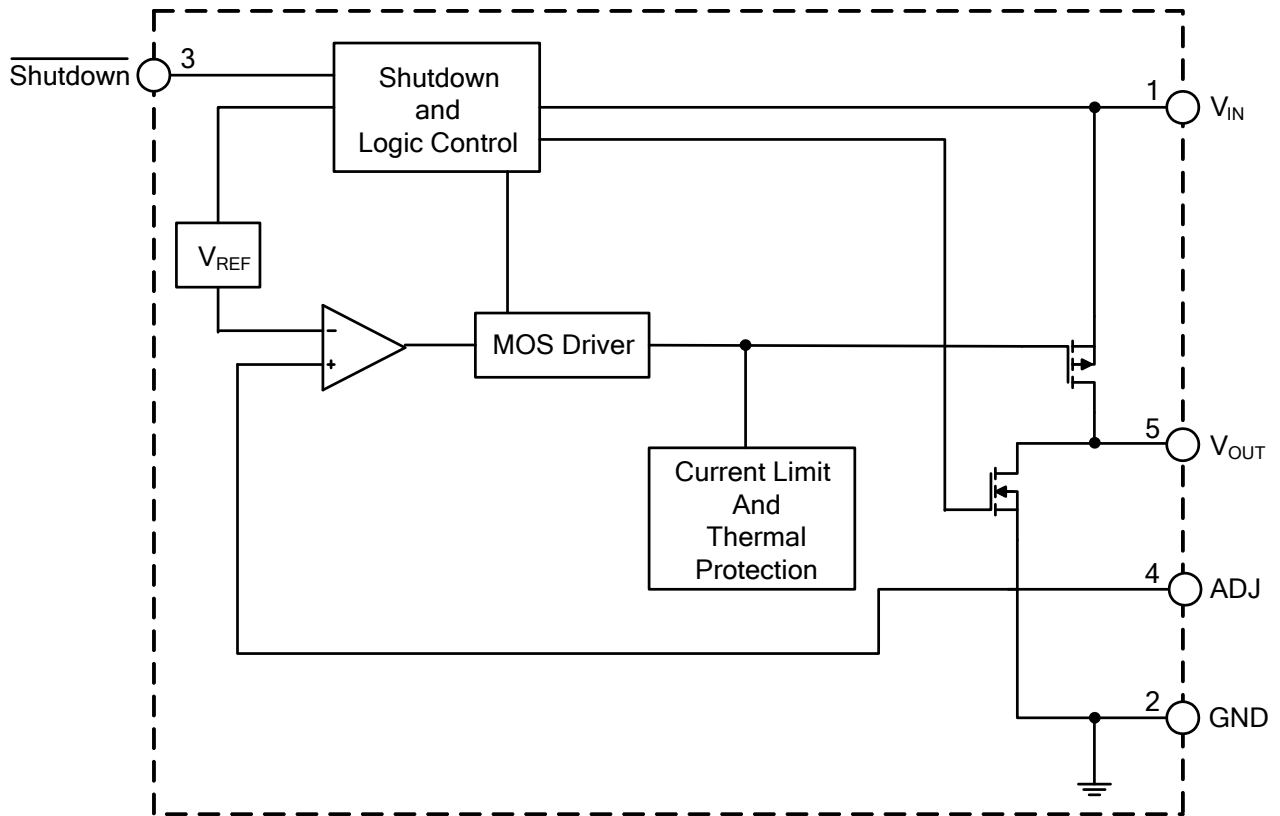

Absolute Maximum Ratings (Note 4)

Symbol	Parameter	Rating	Unit
V_{IN}	Input Voltage	6.5	V
V_{CE}	Shutdown Input Voltage	-0.3 to $V_{IN} + 0.3$	V
I_{OUT}	Output Current	450	mA
T_J	Junction Temperature	+150	°C
T_{STG}	Storage Temperature Range	-65 to +150	°C
T_{LEAD}	Lead Temperature (Soldering, 10sec)	+260	°C
θ_{JA}	Thermal Resistance (Junction to Ambient)	250	°C/W
ESD	ESD (Human Body Model)	6000	V
ESD	ESD (Machine Model)	250	V

Note 4: Stresses greater than those listed under "Absolute Maximum Ratings" may cause permanent damage to the device. These are stress ratings only, and functional operation of the device at these or any other conditions beyond those indicated under "Recommended Operating Conditions" is not implied. Exposure to "Absolute Maximum Ratings" for extended periods may affect device reliability.

Recommended Operating Conditions

Symbol	Parameter	Min	Max	Unit
V_{IN}	Input Voltage	3.0	6	V
T_A	Operating Ambient Temperature Range	-40	+85	°C

Electrical Characteristics (AP2126-ADJ, $V_{IN\ min} = 3.0V$, $C_{IN} = 1\mu F$, $C_{OUT} = 1\mu F$, unless otherwise specified.)

Symbol	Parameter	Conditions	Min	Typ	Max	Unit	
V_{REF}	Reference Voltage	$V_{IN} = 3.0V$, $1mA \leq I_{OUT} \leq 300mA$	1.225	1.25	1.275	V	
V_{IN}	Input Voltage	—	3.0	—	6	V	
$I_{OUT(MAX)}$	Maximum Output Current	$V_{IN} = 3.0V$, $V_{OUT} = 98\% \times V_{OUT}$	300	400	—	mA	
$\frac{\Delta V_{OUT}}{(\Delta I_{OUT} \times V_{OUT})}$	Load Regulation	$V_{IN} = 3.0V$, $1mA \leq I_{OUT} \leq 300mA$	—	—	0.6	%/A	
$\frac{\Delta V_{OUT}}{(\Delta V_{IN} \times V_{OUT})}$	Line Regulation	$V_{IN} = 3.0V$ to $6V$, $I_{OUT} = 30mA$	—	—	0.06	%/V	
I_Q	Quiescent Current	$V_{IN} = 3.0V$, $I_{OUT} = 0mA$	—	60	90	μA	
I_{STD}	Standby Current	$V_{IN} = 3.0V$, $V_{Shutdown}$ in Off Mode	—	0.1	1.0	μA	
PSRR	Power Supply Rejection Ratio	Ripple 1Vp-p $V_{IN} = 3.5V$	f = 100Hz	—	68	—	dB
			f = 1kHz	—	68	—	dB
			f = 10kHz	—	54	—	dB
$\frac{(\Delta V_{OUT}/V_{OUT})}{\Delta T}$	Output Voltage Temperature Coefficient	$I_{OUT} = 30mA$, $-40^\circ C \leq T_A \leq +85^\circ C$	—	± 100	—	ppm/°C	
I_{SHORT}	Short Current Limit	$V_{OUT} = 0V$	—	50	—	mA	
t_{UP}	Soft Start Time	—	—	50	—	μs	
V_{NOISE}	RMS Output Noise	$T_A = +25^\circ C$, $10Hz \leq f \leq 100kHz$, $V_{OUT} = 1.25V$	—	80	—	μV_{rms}	
—	Shutdown "High" Voltage	Shutdown Input Voltage "High"	1.5	—	6	V	
—	Shutdown "Low" Voltage	Shutdown Input Voltage "Low"	0	—	0.4	V	
—	V_{OUT} Discharge MOSFET $R_{DS(ON)}$	Shutdown Input Voltage "Low"	—	60	—	Ω	
—	Shutdown Pull Down Resistance	—	—	3	—	M Ω	
—	Thermal Shutdown	—	—	+165	—	°C	
—	Thermal Shutdown Hysteresis	—	—	+30	—	°C	
θ_{JC}	Thermal Resistance	SOT-23-5	—	150	—	°C/W	

Performance Characteristics

Output Voltage vs. Output Current

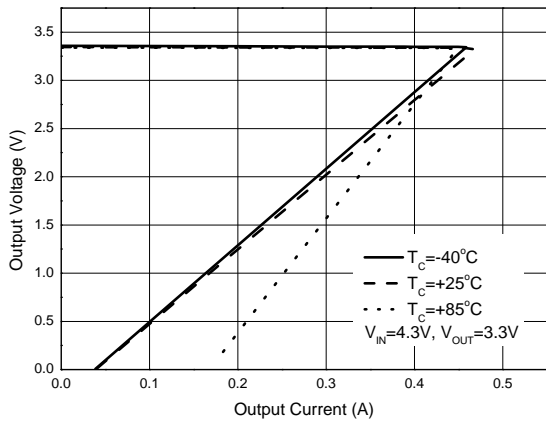

Output Voltage vs. Output Current

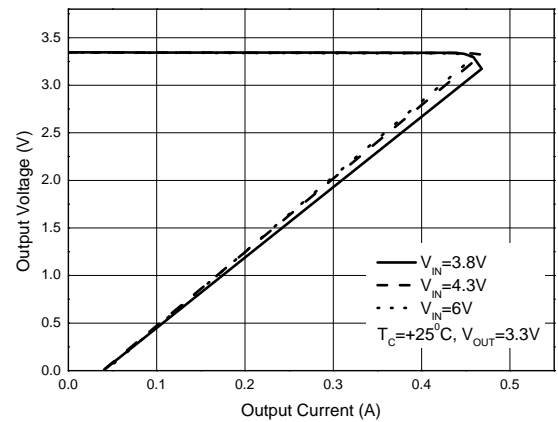

Dropout Voltage vs. Output Current

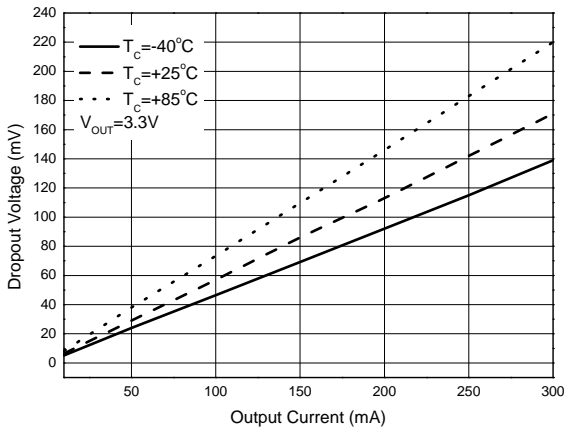

Dropout Voltage vs. Case Temperature

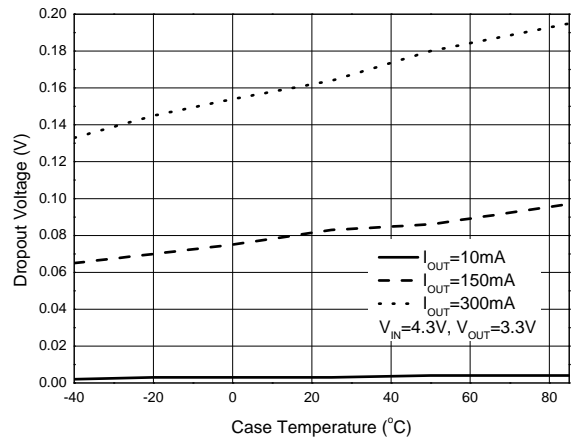

Quiescent Current vs. Output Current

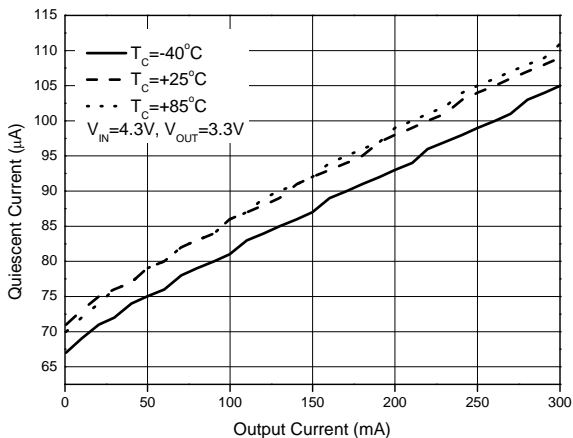

Quiescent Current vs. Case Temperature

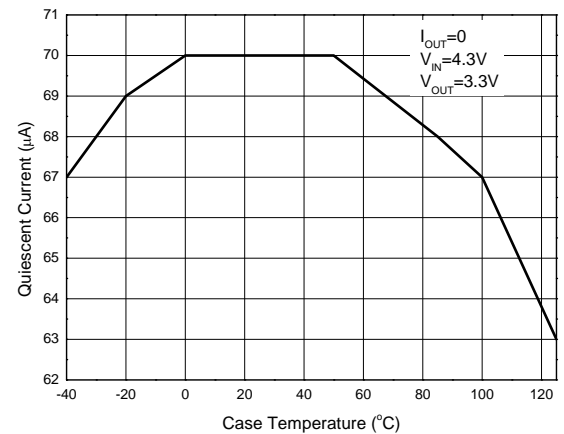

Performance Characteristics (Cont.)

Quiescent Current vs. Input Voltage

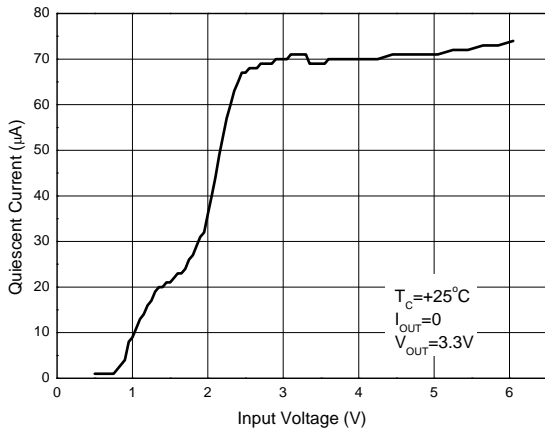

Output Voltage vs. Case Temperature

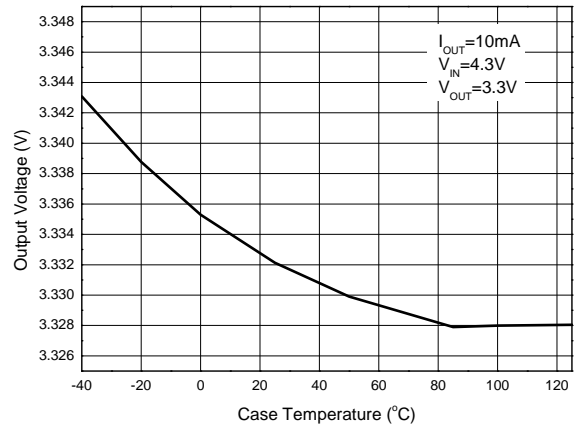

Output Voltage vs. Input Voltage

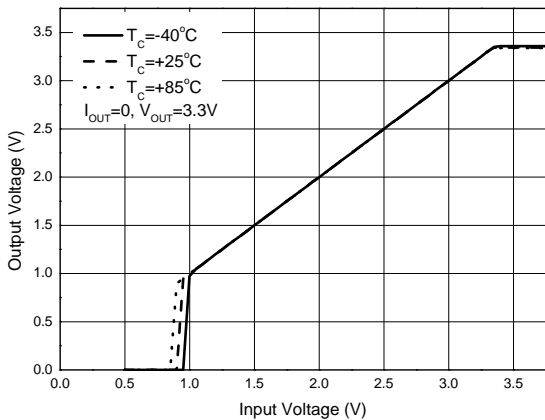

Load Transient
(Conditions: $C_{IN}=C_{OUT}=1\mu F$, $V_{IN}=4.4V$, $V_{OUT}=3.3V$, $I_{OUT}=10mA$ to $300mA$)

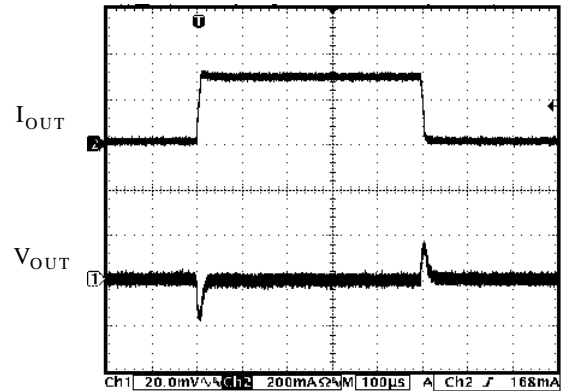

Line Transient
(Conditions: $I_{OUT}=30mA$, $C_{IN}=C_{OUT}=1\mu F$, $V_{IN}=4V$ to $5V$, $V_{OUT}=3.3V$)

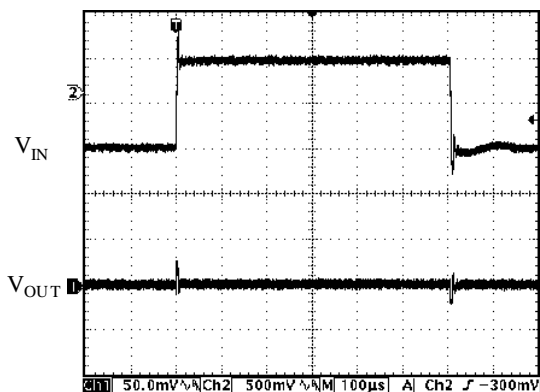

Soft Start Time
(Conditions: $I_{OUT}=0mA$, $C_{IN}=C_{OUT}=1\mu F$, $V_{Shutdown}=0$ to $2V$, $V_{OUT}=3.3V$)

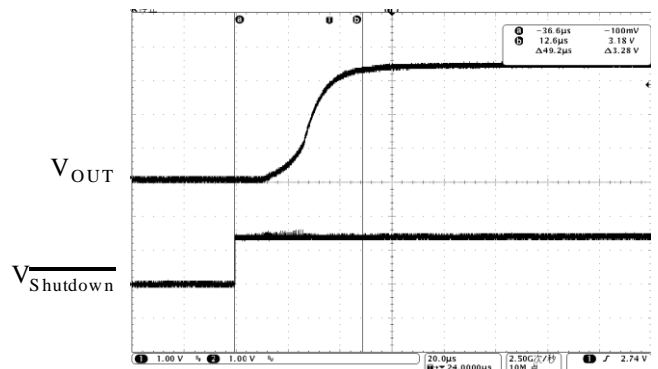

Performance Characteristics (Cont.)

PSRR vs. Frequency

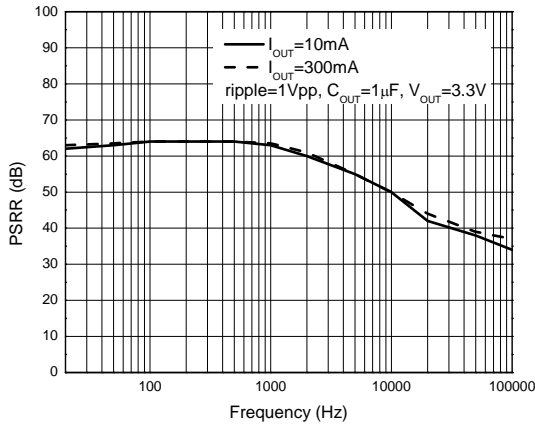

Ordering Information

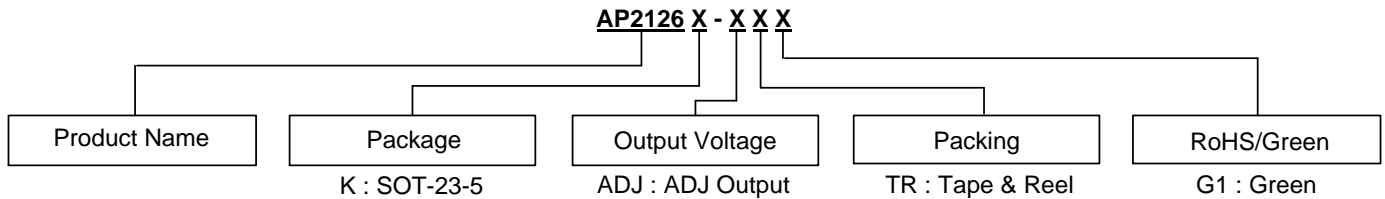

Package	Temperature Range	Part Number	Marking ID	Packing
SOT-23-5	-40 to +85°C	AP2126K-ADJTRG1	GHH	3000/Tape & Reel

Marking Information

(1) SOT-23-5

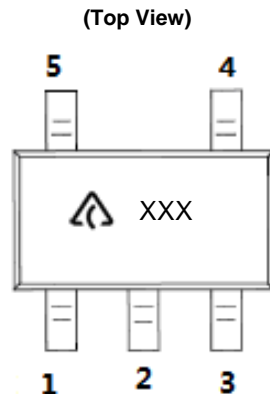

: Logo
 XXX: Marking ID
 (See Ordering Information)

Package Outline Dimensions (All dimensions in mm(inch).)

(1) Package Type: SOT-23-5

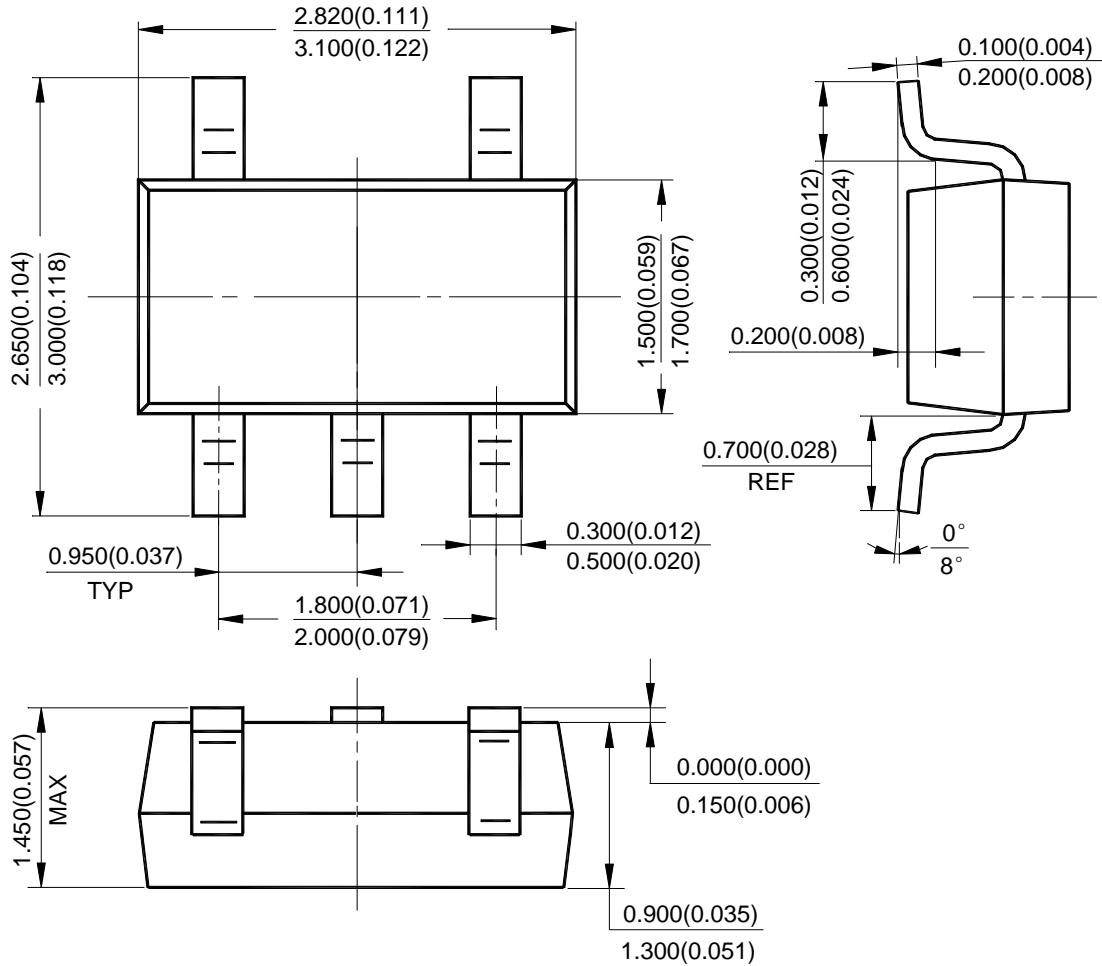

Suggested Pad Layout

(1) Package Type: SOT-23-5

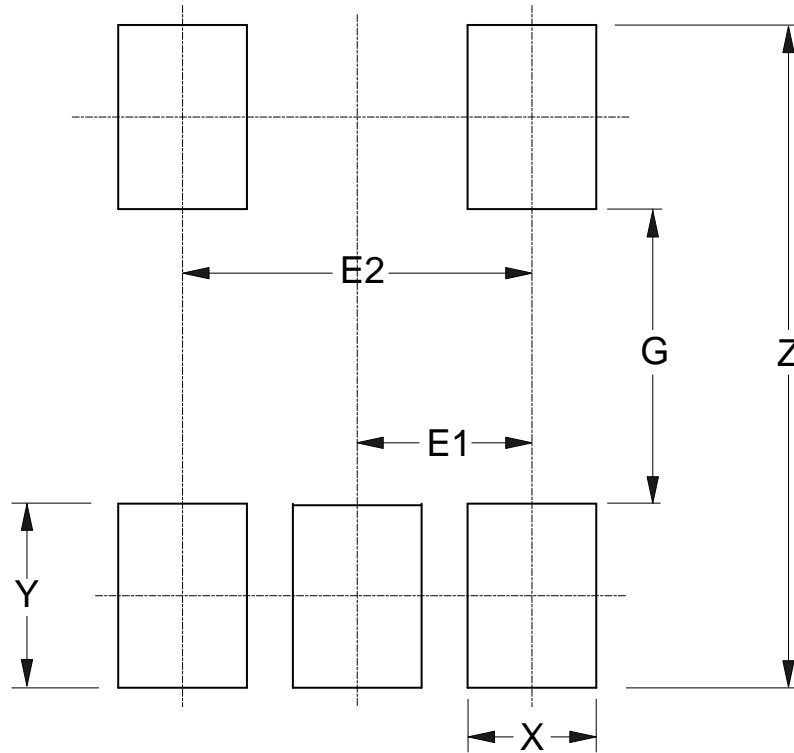

Dimensions	Z (mm)/(inch)	G (mm)/(inch)	X (mm)/(inch)	Y (mm)/(inch)	E1 (mm)/(inch)	E2 (mm)/(inch)
Value	3.600/0.142	1.600/0.063	0.700/0.028	1.000/0.039	0.950/0.037	1.900/0.075

IMPORTANT NOTICE

DIODES INCORPORATED MAKES NO WARRANTY OF ANY KIND, EXPRESS OR IMPLIED, WITH REGARDS TO THIS DOCUMENT, INCLUDING, BUT NOT LIMITED TO, THE IMPLIED WARRANTIES OF MERCHANTABILITY AND FITNESS FOR A PARTICULAR PURPOSE (AND THEIR EQUIVALENTS UNDER THE LAWS OF ANY JURISDICTION).

Diodes Incorporated and its subsidiaries reserve the right to make modifications, enhancements, improvements, corrections or other changes without further notice to this document and any product described herein. Diodes Incorporated does not assume any liability arising out of the application or use of this document or any product described herein; neither does Diodes Incorporated convey any license under its patent or trademark rights, nor the rights of others. Any Customer or user of this document or products described herein in such applications shall assume all risks of such use and will agree to hold Diodes Incorporated and all the companies whose products are represented on Diodes Incorporated website, harmless against all damages.

Diodes Incorporated does not warrant or accept any liability whatsoever in respect of any products purchased through unauthorized sales channel. Should Customers purchase or use Diodes Incorporated products for any unintended or unauthorized application, Customers shall indemnify and hold Diodes Incorporated and its representatives harmless against all claims, damages, expenses, and attorney fees arising out of, directly or indirectly, any claim of personal injury or death associated with such unintended or unauthorized application.

Products described herein may be covered by one or more United States, international or foreign patents pending. Product names and markings noted herein may also be covered by one or more United States, international or foreign trademarks.

This document is written in English but may be translated into multiple languages for reference. Only the English version of this document is the final and determinative format released by Diodes Incorporated.

LIFE SUPPORT

Diodes Incorporated products are specifically not authorized for use as critical components in life support devices or systems without the express written approval of the Chief Executive Officer of Diodes Incorporated. As used herein:

A. Life support devices or systems are devices or systems which:

1. are intended to implant into the body, or
2. support or sustain life and whose failure to perform when properly used in accordance with instructions for use provided in the labeling can be reasonably expected to result in significant injury to the user.

B. A critical component is any component in a life support device or system whose failure to perform can be reasonably expected to cause the failure of the life support device or to affect its safety or effectiveness.

Customers represent that they have all necessary expertise in the safety and regulatory ramifications of their life support devices or systems, and acknowledge and agree that they are solely responsible for all legal, regulatory and safety-related requirements concerning their products and any use of Diodes Incorporated products in such safety-critical, life support devices or systems, notwithstanding any devices- or systems-related information or support that may be provided by Diodes Incorporated. Further, Customers must fully indemnify Diodes Incorporated and its representatives against any damages arising out of the use of Diodes Incorporated products in such safety-critical, life support devices or systems.

Copyright © 2017, Diodes Incorporated

www.diodes.com

单击下面可查看定价，库存，交付和生命周期等信息

[>>Diodes Incorporated\(达尔科技\)](#)