



# **PI7C9X2G808PR**

## **PCI EXPRESS GEN 2 PACKET SWITCH 2/ 5/ 8-Port/ 8-Lane PCI Express Gen 2 Switch Green Package Family**

*Datasheet*  
REVISION 8  
December 2020



A Product Line of  
Diodes Incorporated



1545 Barber Lane Milpitas, CA 95035  
Telephone: 408-232-9100  
FAX: 408-434-1040  
Internet: <http://www.diodes.com>

**IMPORTANT NOTICE**

1. DIODES INCORPORATED AND ITS SUBSIDIARIES (“DIODES”) MAKE NO WARRANTY OF ANY KIND, EXPRESS OR IMPLIED, WITH REGARDS TO ANY INFORMATION CONTAINED IN THIS DOCUMENT, INCLUDING, BUT NOT LIMITED TO, THE IMPLIED WARRANTIES OF MERCHANTABILITY, FITNESS FOR A PARTICULAR PURPOSE OR NON-INFRINGEMENT OF THIRD PARTY INTELLECTUAL PROPERTY RIGHTS (AND THEIR EQUIVALENTS UNDER THE LAWS OF ANY JURISDICTION).

2. The Information contained herein is for informational purpose only and is provided only to illustrate the operation of Diodes products described herein and application examples. Diodes does not assume any liability arising out of the application or use of this document or any product described herein. This document is intended for skilled and technically trained engineering customers and users who design with Diodes products. Diodes products may be used to facilitate safety-related applications; however, in all instances customers and users are responsible for (a) selecting the appropriate Diodes products for their applications, (b) evaluating the suitability of the Diodes products for their intended applications, (c) ensuring their applications, which incorporate Diodes products, comply the applicable legal and regulatory requirements as well as safety and functional-safety related standards, and (d) ensuring they design with appropriate safeguards (including testing, validation, quality control techniques, redundancy, malfunction prevention, and appropriate treatment for aging degradation) to minimize the risks associated with their applications.

3. Diodes assumes no liability for any application-related information, support, assistance or feedback that may be provided by Diodes from time to time. Any customer or user of this document or products described herein will assume all risks and liabilities associated with such use, and will hold Diodes and all companies whose products are represented herein or on Diodes’ websites, harmless against all damages and liabilities.

4. Products described herein may be covered by one or more United States, international or foreign patents and pending patent applications. Product names and markings noted herein may also be covered by one or more United States, international or foreign trademarks and trademark applications. Diodes does not convey any license under any of its intellectual property rights or the rights of any third parties (including third parties whose products and services may be described in this document or on Diodes’ website) under this document.

5. Diodes products are provided subject to Diodes’ Standard Terms and Conditions of Sale (<https://www.diodes.com/about/company/terms-and-conditions/terms-and-conditions-of-sales/>) or other applicable terms. This document does not alter or expand the applicable warranties provided by Diodes. Diodes does not warrant or accept any liability whatsoever in respect of any products purchased through unauthorized sales channel.

6. Diodes products and technology may not be used for or incorporated into any products or systems whose manufacture, use or sale is prohibited under any applicable laws and regulations. Should customers or users use Diodes products in contravention of any applicable laws or regulations, or for any unintended or unauthorized application, customers and users will (a) be solely responsible for any damages, losses or penalties arising in connection therewith or as a result thereof, and (b) indemnify and hold Diodes and its representatives and agents harmless against any and all claims, damages, expenses, and attorney fees arising out of, directly or indirectly, any claim relating to any noncompliance with the applicable laws and regulations, as well as any unintended or unauthorized application.

7. While efforts have been made to ensure the information contained in this document is accurate, complete and current, it may contain technical inaccuracies, omissions and typographical errors. Diodes does not warrant that information contained in this document is error-free and Diodes is under no obligation to update or otherwise correct this information. Notwithstanding the foregoing, Diodes reserves the right to make modifications, enhancements, improvements, corrections or other changes without further notice to this document and any product described herein. This document is written in English but may be translated into multiple languages for reference. Only the English version of this document is the final and determinative format released by Diodes.

8. Any unauthorized copying, modification, distribution, transmission, display or other use of this document (or any portion hereof) is prohibited. Diodes assumes no responsibility for any losses incurred by the customers or users or any third parties arising from any such unauthorized use.

Copyright © 2020 Diodes Incorporated

[www.diodes.com](http://www.diodes.com)

## REVISION HISTORY

Date	Revision Number	Description
06/24/2015	0.1	Preliminary Datasheet (Short-Form)
11/24/2015	0.2	Updated Section 3 Pin Description Updated Section 5.3 Port-Lane Mapping Updated Section 6.1 Physical Layer Circuit Updated Section 6.13 Non-Transparent Bridging Updated Figure 4-1 PI7C9X2G808PR Ball Assignment
12/23/2015	0.3	Updated Section 3 Pin Description Updated Section 6 Functional Description Updated Section 7 EEPROM Interface and System Management/I2C Bus Updated Section 8 Register Description Updated Section 9 Clock Scheme Updated Section 10 Power Management Updated Section 11 IEEE 1149.1 Compatible JTAG Controller Updated Section 12 Electrical and Timing Specifications
01/22/2016	0.4	Removed Section 8.4.76 EEPROM_Scratchpad Updated Section 12.2 DC Specifications Updated Section 8.2.142 Non Transfer Mode Register Updated Section 8.3.111 Non Transfer Mode Register
03/29/2016	0.5	Updated Section 3.4 Miscellaneous Signals (42 BALLS) Updated Figure 6-2 Intelligent Adaptor Architecture Updated Section 8.2.87 NT-UP Port Selection Register Update Section 8.2.88 Hot Plug Configuration Register Updated Section 8.2.142 Non Transfer Mode Register Removed Section 8.2.182 Clock Buffer Control Register Removed Section 8.2.183 Clock Buffer Port Select Register Updated Section 8.3.74 NT-UP Port Selection Register Update Section 8.3.75 Hot Plug Configuration Register Updated Section 8.3.111 NON Transfer Mode Register Removed Section 8.3.161 Clock Buffer Control Register Removed Section 8.3.162 Clock Buffer Port Select Register Updated Section 8.4.36 Link Control 2 Register Added Section 11 Power Sequence
12/23/2016	0.6	Updated Section 8 Register Description Updated Table 13-2 DC Electrical Characteristics
01/26/2017	1.0	Remove "Preliminary" Updated Section 1 Features Updated Section 3.6 Power Pins (75 Balls) Updated Section 8.2 Transparent Mode Configuration Registers Updated Section 13.1 Absolute Maximum Ratings Updated Section 13.2 DC Specifications Added Section 13.4 Operating Ambient Temperature
02/13/2017	1.1	Updated Section 3.1 PCI Express Interface Signals (40 BALLS) Updated Section 3.4 Miscellaneous Signals (45 BALLS) Updated Section 15 Ordering Information Updated Section 13.1 Absolute Maximum Ratings
10/13/2017	2	Updated Section 7 EEPROM Interface and System Management/I2C Bus Updated Section 8 Register Description Updated Table 13.2 DC Electrical Characteristics Added Table 13-8 Power Consumption Added Section 14 Thermal Data Updated Section 16 Ordering Information Revision numbering system changed to whole number
11/16/2017	3	Updated Section 3.6 Power Pins (75 Balls) Updated Section 3.2 Port Specific Signals (21 Balls) Updated Table 13-1 Absolute Maximum Ratings
01/17/2018	4	Updated Section 1 Features

		Updated Section 8.2.117 PHY PARAMETER 2 REGISTER Updated Section 8.2.118 PHY PARAMETER 3 REGISTER Updated Section 8.2.136 PORT MISC 0 REGISTER Updated Table 12-3 JTAG Boundary Scan Register Definition Updated Table 13-8 Power Consumption Added Figure 15-2 Part Marking Updated Section 16 Ordering Information
05/15/2019	5	Updated Section 1 Features Updated Section 3.1 PCI Express Interface Signals (40 Balls) Updated Section 7 EEPROM Interface And System Management/I2c Bus 8.2.114 Switch Operation Mode Register – Offset 850h (Upstream Port Only)
8/13/2019	6	Updated 8.2.53 Link Control Register 2 Updated Section 13.1 Absolute Maximum Ratings Update Figure 15-2 Part Marking
05/14/2020	7	Updated Section 1 Features Updated Section 3.2 Port Specific Signals (21 Balls) Updated Section 6.1 Physical Layer Circuit Updated Section 8.2.126 EEPROM Control Register Updated Section 16 Ordering Information
12/15/2020	8	For Datasheet Status Change

## TABLE OF CONTENTS

<b>1</b>	<b>FEATURES.....</b>	<b>16</b>
<b>2</b>	<b>GENERAL DESCRIPTION.....</b>	<b>17</b>
<b>3</b>	<b>PIN DESCRIPTION.....</b>	<b>19</b>
3.1	PCI EXPRESS INTERFACE SIGNALS (40 BALLS) .....	19
3.2	PORT SPECIFIC SIGNALS (21 BALLS).....	19
3.3	EEPROM AND SMBUS/I2C SIGNALS (10 BALLS).....	20
3.4	MISCELLANEOUS SIGNALS (45 BALLS).....	21
3.5	JTAG BOUNDARY SCAN SIGNALS (5 BALLS).....	21
3.6	POWER PINS (75 BALLS).....	22
<b>4</b>	<b>PIN DESCRIPTION.....</b>	<b>23</b>
4.1	PIN LIST OF 196-BALL LBGA.....	23
<b>5</b>	<b>MODE SELECTION AND PORT-LANE MAPPING.....</b>	<b>25</b>
5.1	MODE SELECTION .....	25
5.2	LANE MAPPING.....	25
5.3	PORT-LANE MAPPING.....	25
<b>6</b>	<b>FUNCTIONAL DESCRIPTION.....</b>	<b>27</b>
6.1	PHYSICAL LAYER CIRCUIT .....	27
6.1.1	RECEIVER DETECTION.....	27
6.1.2	RECEIVER SIGNAL DETECTION.....	28
6.1.3	RECEIVER EQUALIZATION.....	28
6.1.4	TRANSMITTER SWING.....	28
6.1.5	DRIVE AMPLITUDE AND DE-EMPHASIS SETTINGS.....	28
6.1.6	DRIVE AMPLITUDE.....	29
6.1.7	DRIVE DE-EMPHASIS.....	30
6.1.8	TRANSMITTER ELECTRICAL IDLE LATENCY.....	30
6.2	DATA LINK LAYER (DLL).....	30
6.3	TRANSACTION LAYER RECEIVE BLOCK (TLP DECAPSULATION) .....	31
6.4	ROUTING .....	31
6.5	TC/VC MAPPING.....	31
6.6	QUEUE.....	32
6.6.1	PH.....	32
6.6.2	PD.....	32
6.6.3	NPHD .....	32
6.6.4	CPLH.....	32
6.6.5	CPLD.....	32
6.7	TRANSACTION ORDERING.....	33
6.8	PORT ARBITRATION .....	33
6.9	VC ARBITRATION .....	34
6.10	FLOW CONTROL .....	34
6.11	TRANSACTION LAYER TRANSMIT BLOCK (TLP ENCAPSULATION) .....	34
6.12	ACCESS CONTROL SERVICE.....	34
6.13	NON-TRANSPARENT BRIDGING (NT MODE ONLY).....	34
6.13.1	Device Type Identification .....	35
6.13.2	Intelligent Adaptor.....	35
6.13.3	Interrupts Request (IRQ) Registers.....	36
6.13.4	Scratchpad Registers .....	36

6.13.5	NT Base Address Registers .....	37
6.13.6	Routing ID Translation .....	37
<b>7</b>	<b>EEPROM INTERFACE AND SYSTEM MANAGEMENT/I2C BUS .....</b>	<b>38</b>
7.1	EEPROM INTERFACE .....	38
7.1.1	AUTO MODE EEPROM ACCESS .....	38
7.1.2	EEPROM MODE AT RESET .....	38
7.1.3	EEPROM SPACE ADDRESS MAP .....	38
7.2	SMBUS INTERFACE .....	39
7.2.1	SMBUS BLOCK WRITE .....	40
7.2.2	SMBUS BLOCK READ .....	41
7.2.3	CSR READ, USING SMBUS BLOCK READ – BLOCK WRITE PROCESS CALL .....	44
7.3	I <sup>2</sup> C SLAVE INTERFACE .....	45
7.3.1	I <sup>2</sup> C REGISTER WRITE ACCESS .....	46
7.3.2	I <sup>2</sup> C REGISTER READ ACCESS .....	48
<b>8</b>	<b>REGISTER DESCRIPTION .....</b>	<b>51</b>
8.1	REGISTER TYPES .....	51
8.2	TRANSPARENT MODE CONFIGURATION REGISTERS .....	51
8.2.1	VENDOR ID REGISTER – OFFSET 00h .....	54
8.2.2	DEVICE ID REGISTER – OFFSET 00h .....	54
8.2.3	COMMAND REGISTER – OFFSET 04h .....	54
8.2.4	PRIMARY STATUS REGISTER – OFFSET 04h .....	55
8.2.5	REVISION ID REGISTER – OFFSET 08h .....	56
8.2.6	CLASS REGISTER – OFFSET 08h .....	56
8.2.7	CACHE LINE REGISTER – OFFSET 0Ch .....	56
8.2.8	PRIMARY LATENCY TIMER REGISTER – OFFSET 0Ch .....	56
8.2.9	HEADER TYPE REGISTER – OFFSET 0Ch .....	56
8.2.10	BASE ADDRESS 0 REGISTER – OFFSET 10h (Upstream Port Only) .....	56
8.2.11	BASE ADDRESS 1 REGISTER – OFFSET 14h (Upstream Port Only) .....	57
8.2.12	PRIMARY BUS NUMBER REGISTER – OFFSET 18h .....	57
8.2.13	SECONDARY BUS NUMBER REGISTER – OFFSET 18h .....	57
8.2.14	SUBORDINATE BUS NUMBER REGISTER – OFFSET 18h .....	57
8.2.15	SECONDARY LATENCY TIMER REGISTER – OFFSET 18h .....	57
8.2.16	I/O BASE ADDRESS REGISTER – OFFSET 1Ch .....	57
8.2.17	I/O LIMIT ADDRESS REGISTER – OFFSET 1Ch .....	58
8.2.18	SECONDARY STATUS REGISTER – OFFSET 1Ch .....	58
8.2.19	MEMORY BASE ADDRESS REGISTER – OFFSET 20h .....	58
8.2.20	MEMORY LIMIT ADDRESS REGISTER – OFFSET 20h .....	58
8.2.21	PREFETCHABLE MEMORY BASE ADDRESS REGISTER – OFFSET 24h .....	59
8.2.22	PREFETCHABLE MEMORY LIMIT ADDRESS REGISTER – OFFSET 24h .....	59
8.2.23	PREFETCHABLE MEMORY BASE ADDRESS UPPER 32-BITS REGISTER – OFFSET 28h .....	59
8.2.24	PREFETCHABLE MEMORY LIMIT ADDRESS UPPER 32-BITS REGISTER – OFFSET 2Ch .....	59
8.2.25	I/O BASE ADDRESS UPPER 16-BITS REGISTER – OFFSET 30h .....	59
8.2.26	I/O LIMIT ADDRESS UPPER 16-BITS REGISTER – OFFSET 30h .....	60
8.2.27	CAPABILITY POINTER REGISTER – OFFSET 34h .....	60
8.2.28	INTERRUPT LINE REGISTER – OFFSET 3Ch .....	60
8.2.29	INTERRUPT PIN REGISTER – OFFSET 3Ch .....	60
8.2.30	BRIDGE CONTROL REGISTER – OFFSET 3Ch .....	60
8.2.31	POWER MANAGEMENT CAPABILITIES REGISTER – OFFSET 40h .....	61
8.2.32	POWER MANAGEMENT DATA REGISTER – OFFSET 44h .....	61
8.2.33	PPB SUPPORT EXTENSIONS REGISTER – OFFSET 44h .....	62
8.2.34	DATA REGISTER – OFFSET 44h .....	62
8.2.35	MSI CAPABILITIES REGISTER – OFFSET 48h .....	62

8.2.36	MESSAGE ADDRESS REGISTER – OFFSET 4Ch	62
8.2.37	MESSAGE UPPER ADDRESS REGISTER – OFFSET 50h	63
8.2.38	MESSAGE DATA REGISTER – OFFSET 54h	63
8.2.39	PCI EXPRESS CAPABILITIES REGISTER – OFFSET 68h	63
8.2.40	DEVICE CAPABILITIES REGISTER – OFFSET 6Ch	63
8.2.41	DEVICE CONTROL REGISTER – OFFSET 70h	64
8.2.42	DEVICE STATUS REGISTER – OFFSET 70h	65
8.2.43	LINK CAPABILITIES REGISTER – OFFSET 74h	65
8.2.44	LINK CONTROL REGISTER – OFFSET 78h	66
8.2.45	LINK STATUS REGISTER – OFFSET 78h	66
8.2.46	SLOT CAPABILITIES REGISTER – OFFSET 7Ch (Downstream Port Only)	67
8.2.47	SLOT CONTROL REGISTER – OFFSET 80h (Downstream Port Only)	68
8.2.48	SLOT STATUS REGISTER – OFFSET 80h (Downstream Port Only)	68
8.2.49	DEVICE CAPABILITIES REGISTER 2 – OFFSET 8Ch	69
8.2.50	DEVICE CONTROL REGISTER 2 – OFFSET 90h	69
8.2.51	DEVICE STATUS REGISTER 2 – OFFSET 90h	69
8.2.52	LINK CAPABILITIES REGISTER 2 – OFFSET 94h	69
8.2.53	LINK CONTROL REGISTER 2 – OFFSET 98h	70
8.2.54	LINK STATUS REGISTER 2 – OFFSET 98h	70
8.2.55	SLOT CAPABILITIES REGISTER 2 – OFFSET 9Ch	70
8.2.56	SLOT CONTROL REGISTER 2 – OFFSET A0h	70
8.2.57	SLOT STATUS REGISTER 2 – OFFSET A0h	70
8.2.58	SSID/SSVID CAPABILITIES REGISTER – OFFSET A4h	70
8.2.59	SUBSYSTEM VENDOR ID REGISTER – OFFSET A8h	71
8.2.60	SUBSYSTEM ID REGISTER – OFFSET A8h	71
8.2.61	BAR 0-1 CONFIGURATION REGISTER – OFFSET E4h (Upstream Port Only)	71
8.2.62	DEVICE SERIAL NUMBER ENHANCED CAPABILITY HEADER REGISTER – OFFSET 100h	71
8.2.63	DEVICE SERIAL NUMBER LOWER DW REGISTER – OFFSET 104h	71
8.2.64	DEVICE SERIAL NUMBER HIGHER DW REGISTER – OFFSET 108h	72
8.2.65	PCI EXPRESS POWER BUDGETING ENHANCED CAPABILITY HEADER REGISTER – OFFSET 138h (Upstream Port Only)	72
8.2.66	DATA SELECT REGISTER – OFFSET 13Ch (Upstream Port Only)	72
8.2.67	POWER BUDGETING DATA REGISTER – OFFSET 140h (Upstream Port Only)	72
8.2.68	POWER BUDGET CAPABILITY REGISTER – OFFSET 144h (Upstream Port Only)	73
8.2.69	PCI EXPRESS VIRTUAL CHANNEL ENHANCED CAPABILITY HEADER REGISTER – OFFSET 148h	73
8.2.70	PORT VC CAPABILITY REGISTER 1 – OFFSET 14Ch	73
8.2.71	PORT VC CAPABILITY REGISTER 2 – OFFSET 150h	73
8.2.72	PORT VC CONTROL REGISTER – OFFSET 154h	74
8.2.73	PORT VC STATUS REGISTER – OFFSET 154h	74
8.2.74	VC RESOURCE CAPABILITY REGISTER (0) – OFFSET 158h	74
8.2.75	VC RESOURCE CONTROL REGISTER (0) – OFFSET 15Ch	74
8.2.76	VC RESOURCE STATUS REGISTER (0) – OFFSET 160h	75
8.2.77	VC RESOURCE CAPABILITY REGISTER (1) – OFFSET 164h	75
8.2.78	VC RESOURCE CONTROL REGISTER (1) – OFFSET 168h	75
8.2.79	VC RESOURCE STATUS REGISTER (1) – OFFSET 16Ch	76
8.2.80	VC ARBITRATION TABLE REGISTER – OFFSET 188h	76
8.2.81	PORT ARBITRATION TABLE REGISTER (0) and (1) – OFFSET 198h and 1A8h	76
8.2.82	ECC ERROR CHECK DISABLE REGISTER – OFFSET 1C8h (Global)	77
8.2.83	NT-UP PORT SELECTION REGISTER – OFFSET 1DCh (Global)	77
8.2.84	HOT PLUG CONFIGURATION REGISTER – OFFSET 1E0h	77
8.2.85	SOFTWARE LANE STATUS REGISTER – OFFSET 1F4h (Global)	78
8.2.86	DE-EMPHASIS AND RATE CONTROL REGISTER – OFFSET 208h (Upstream Port Only)	78
8.2.87	COMPLIANCE MODE CONTROL REGISTER – OFFSET 20Ch	79

8.2.88	<i>EVEN PORT PHYSICAL LAYER COMMAND AND STATUS REGISTER – OFFSET 220h (Global)</i>	79
8.2.89	<i>ODD PORT PHYSICAL LAYER COMMAND AND STATUS REGISTER – OFFSET 224h (Global)</i>	79
8.2.90	<i>EVEN PORT DISABLE/QUIET/TEST PATTERN RATE REGISTER – OFFSET 230h (Global)</i>	80
8.2.91	<i>ODD PORT DISABLE/QUIET/TEST PATTERN RATE REGISTER – OFFSET 234h (Global)</i>	81
8.2.92	<i>L1 PM SUBSTATES ENHANCED CAPABILITY HEADER – OFFSET 270h</i>	81
8.2.93	<i>L1 PM SUBSTATES CAPABILITY REGISTER – OFFSET 274h</i>	81
8.2.94	<i>L1 PM SUBSTATES CONTROL 1 REGISTER – OFFSET 278h</i>	81
8.2.95	<i>L1 PM SUBSTATES CONTROL 2 REGISTER – OFFSET 27Ch</i>	82
8.2.96	<i>SMBUS CONTROL AND STATUS REGISTER – OFFSET 344h (Upstream Port Only)</i>	82
8.2.97	<i>DISABLE DOWNSTREAM PORT HOT RESET REGISTER – OFFSET 34Ch (Upstream Port Only)</i>	82
8.2.98	<i>ACS ENHANCED CAPABILITY HEADER REGISTER – OFFSET 520h (Downstream Port Only)</i>	82
8.2.99	<i>ACS CAPABILITY REGISTER – OFFSET 524h (Downstream Port Only)</i>	83
8.2.100	<i>EGRESS CONTROL VECTOR REGISTER – OFFSET 528h (Downstream Port Only)</i>	83
8.2.101	<i>GPIO 0-15 DIRECTION CONTROL REGISTER – OFFSET 62Ch (Upstream Port Only)</i>	84
8.2.102	<i>GPIO 16-31 DIRECTION CONTROL REGISTER – OFFSET 630h (Upstream Port Only)</i>	86
8.2.103	<i>GPIO INPUT DE-BOUNCE REGISTER – OFFSET 638h (Upstream Port Only)</i>	88
8.2.104	<i>GPIO 0-15 INPUT DATA REGISTER – OFFSET 63Ch (Global)</i>	88
8.2.105	<i>GPIO 16-31 INPUT DATA REGISTER – OFFSET 640h (Global)</i>	89
8.2.106	<i>GPIO 0-15 OUTPUT DATA REGISTER – OFFSET 644h (Upstream Port Only)</i>	90
8.2.107	<i>GPIO 16-31 OUTPUT DATA REGISTER – OFFSET 648h (Upstream Port Only)</i>	91
8.2.108	<i>GPIO 0-31 INTERRUPT POLARITY REGISTER – OFFSET 64Ch (Upstream Port Only)</i>	92
8.2.109	<i>GPIO 0-31 INTERRUPT STATUS REGISTER – OFFSET 650h (Global)</i>	92
8.2.110	<i>GPIO 0-31 INTERRUPT MASK REGISTER – OFFSET 654h (Upstream Port Only)</i>	93
8.2.111	<i>XPIP_CSR 0 REGISTER – OFFSET 844h</i>	93
8.2.112	<i>XPIP_CSR 1 REGISTER – OFFSET 848h</i>	93
8.2.113	<i>DECODE VGA REGISTER – OFFSET 84Ch</i>	93
8.2.114	<i>SWITCH OPERATION MODE REGISTER – OFFSET 850h (Upstream Port Only)</i>	93
8.2.115	<i>XPIP_CSR 2 REGISTER – OFFSET 854h</i>	94
8.2.116	<i>PHY PARAMETER 1 REGISTER – OFFSET 854h (Upstream Port Only)</i>	94
8.2.117	<i>PHY PARAMETER 2 REGISTER – OFFSET 858h</i>	95
8.2.118	<i>PHY PARAMETER 3 REGISTER – OFFSET 85Ch</i>	95
8.2.119	<i>PHY PARAMETER 4 REGISTER – OFFSET 860h (Upstream Port Only)</i>	95
8.2.120	<i>XPIP_CSR 3 REGISTER – OFFSET 864h</i>	96
8.2.121	<i>XPIP_CSR 4 REGISTER – OFFSET 868h (Upstream Port Only)</i>	96
8.2.122	<i>XPIP_CSR 5 REGISTER – OFFSET 86Ch</i>	96
8.2.123	<i>NON TRANSFER MODE REGISTER – OFFSET 870h (Upstream Port Only)</i>	96
8.2.124	<i>OPERATION MODE REGISTER – OFFSET 874h</i>	97
8.2.125	<i>DEVICE SPECIFIC POWER MANAGEMENT EVENT – OFFSET 878h (Downstream Port Only)</i>	97
8.2.126	<i>EEPROM CONTROL REGISTER – OFFSET 87Ch (Upstream Port Only)</i>	97
8.2.127	<i>EEPROM ADDRESS AND DATA REGISTER – OFFSET 880h (Upstream Port Only)</i>	98
8.2.128	<i>DEBUGOUT CONTROL REGISTER – OFFSET 884h (Upstream Port Only)</i>	98
8.2.129	<i>DEBUGOUT DATA REGISTER – OFFSET 888h (Upstream Port Only)</i>	98
8.2.130	<i>LTSSM_CSR REGISTER – OFFSET 88Ch (Downstream Port Only)</i>	98
8.2.131	<i>MAC_CSR REGISTER – OFFSET 890h</i>	99
8.2.132	<i>POWER SAVING DISABLE REGISTER – OFFSET 8A4h</i>	99
8.2.133	<i>TRANSACTION LAYER CSR REGISTER – OFFSET 8A8h</i>	99
8.2.134	<i>REPLAY TIME-OUT COUNTER REGISTER – OFFSET 8ACh</i>	99
8.2.135	<i>ACKNOWLEDGE LATENCY TIMER REGISTER – OFFSET 8ACh</i>	99
8.2.136	<i>PORT MISC 0 REGISTER – OFFSET 8B0h</i>	100
8.2.137	<i>PHY PARAMETER 0 REGISTER – OFFSET 8B0h (Upstream Port Only)</i>	100
8.2.138	<i>PORT MISC 1 REGISTER – OFFSET 8B4h</i>	100



8.2.139	XPIP_CSR 6 REGISTER – OFFSET 8B4h.....	100
8.2.140	XPIP_CSR 7 REGISTER – OFFSET 8B4h.....	100
8.2.141	PORT MISC 2 REGISTER – OFFSET 8B8h.....	101
8.2.142	LED DISPLAY CSR REGISTER – OFFSET 8BCh (Global).....	101
8.2.143	MULTI-CAST ENHANCED CAPABILITY HEADER REGISTER – OFFSET 900h.....	101
8.2.144	MULTI-CAST CAPABILITY REGISTER – OFFSET 904h.....	101
8.2.145	MULTI-CAST CONTROL REGISTER – OFFSET 904h.....	102
8.2.146	MULTI-CAST BASE ADDRESS 0 REGISTER – OFFSET 908h.....	102
8.2.147	MULTI-CAST BASE ADDRESS 1 REGISTER – OFFSET 90Ch.....	102
8.2.148	MULTI-CAST RECEIVER REGISTER – OFFSET 910h.....	102
8.2.149	MULTI-CAST BLOCK ALL REGISTER – OFFSET 918h.....	102
8.2.150	MULTI-CAST BLOCK UNTRANSLATED REGISTER – OFFSET 920h.....	102
8.2.151	EEPROM_SCRATCHPAD REGISTER - OFFSET FB0h.....	103
8.2.152	PCI EXPRESS ADVANCED ERROR REPORTING ENHANCED CAPABILITY HEADER REGISTER – OFFSET FB4h.....	103
8.2.153	UNCORRECTABLE ERROR STATUS REGISTER – OFFSET FB8h.....	103
8.2.154	UNCORRECTABLE ERROR MASK REGISTER – OFFSET FBCh.....	104
8.2.155	UNCORRECTABLE ERROR SEVERITY REGISTER – OFFSET FC0h.....	104
8.2.156	CORRECTABLE ERROR STATUS REGISTER – OFFSET FC4h.....	105
8.2.157	CORRECTABLE ERROR MASK REGISTER – OFFSET FC8h.....	105
8.2.158	ADVANCE ERROR CAPABILITIES AND CONTROL REGISTER – OFFSET FCCCh.....	106
8.2.159	HEADER LOG REGISTER – OFFSET From FD0h to FDCh.....	106
8.3	NON TRANSPARENT PORT LINK INTERFACE CONFIGURATION REGISTERS – NT MODE ONLY	107
8.3.1	VENDOR ID REGISTER – OFFSET 00h.....	110
8.3.2	DEVICE ID REGISTER – OFFSET 00h.....	110
8.3.3	COMMAND REGISTER – OFFSET 04h.....	110
8.3.4	PRIMARY STATUS REGISTER – OFFSET 04h.....	111
8.3.5	REVISION ID REGISTER – OFFSET 08h.....	111
8.3.6	CLASS CODE REGISTER – OFFSET 08h.....	111
8.3.7	CACHE LINE REGISTER – OFFSET 0Ch.....	111
8.3.8	PRIMARY LATENCY TIMER REGISTER – OFFSET 0Ch.....	112
8.3.9	HEADER TYPE REGISTER – OFFSET 0Ch.....	112
8.3.10	BAR 0 REGISTER – OFFSET 10h.....	112
8.3.11	BAR 1 REGISTER – OFFSET 14h.....	112
8.3.12	BAR 2 REGISTER – OFFSET 18h.....	112
8.3.13	BAR 3 REGISTER – OFFSET 1Ch.....	113
8.3.14	BAR 4 REGISTER – OFFSET 20h.....	113
8.3.15	BAR 5 REGISTER – OFFSET 24h.....	113
8.3.16	SUBSYSTEM VENDOR ID REGISTER – OFFSET 2Ch.....	113
8.3.17	SUBSYSTEM ID REGISTER – OFFSET 2Ch.....	114
8.3.18	CAPABILITY POINTER REGISTER – OFFSET 34h.....	114
8.3.19	INTERRUPT LINE REGISTER – OFFSET 3Ch.....	114
8.3.20	INTERRUPT PIN REGISTER – OFFSET 3Ch.....	114
8.3.21	POWER MANAGEMENT CAPABILITIES REGISTER – OFFSET 40h.....	114
8.3.22	POWER MANAGEMENT DATA REGISTER – OFFSET 44h.....	115
8.3.23	PPB SUPPORT EXTENSIONS – OFFSET 44h.....	115
8.3.24	DATA REGISTER – OFFSET 44h.....	115
8.3.25	MSI CAPABILITIES REGISTER – OFFSET 48h.....	115
8.3.26	MESSAGE ADDRESS REGISTER – OFFSET 4Ch.....	116
8.3.27	MESSAGE UPPER ADDRESS REGISTER – OFFSET 50h.....	116
8.3.28	MESSAGE DATA REGISTER – OFFSET 54h.....	116
8.3.29	PCI EXPRESS CAPABILITIES REGISTER – OFFSET 68h.....	116
8.3.30	DEVICE CAPABILITIES REGISTER – OFFSET 6Ch.....	116

8.3.31	DEVICE CONTROL REGISTER – OFFSET 70h.....	117
8.3.32	DEVICE STATUS REGISTER – OFFSET 70h.....	117
8.3.33	LINK CAPABILITIES REGISTER – OFFSET 74h.....	118
8.3.34	LINK CONTROL REGISTER – OFFSET 78h.....	119
8.3.35	LINK STATUS REGISTER – OFFSET 78h.....	119
8.3.36	LINK CONTROL REGISTER 2 – OFFSET 94h.....	120
8.3.37	LINK CONTROL REGISTER 2 – OFFSET 98h.....	120
8.3.38	LINK STATUS REGISTER 2 – OFFSET 98h.....	120
8.3.39	SSID/SSVID CAPABILITIES REGISTER – OFFSET A4h.....	120
8.3.40	SUBSYSTEM VENDOR ID REGISTER – OFFSET A8h.....	120
8.3.41	SUBSYSTEM ID REGISTER – OFFSET A8h.....	121
8.3.42	VENDOR SPECIFIC CAPABILITIES REGISTER – OFFSET C8h.....	121
8.3.43	VENDOR SPECIFIC HEADER REGISTER – OFFSET CCh.....	121
8.3.44	NT PORT LINK INTERFACE BAR 0-1 CONFIGURATION REGISTER – OFFSET E4h.....	121
8.3.45	NT PORT LINK INTERFACE BAR 2 CONFIGURATION REGISTER – OFFSET E8h.....	121
8.3.46	NT PORT LINK INTERFACE BAR 2-3 CONFIGURATION REGISTER – OFFSET ECh.....	122
8.3.47	NT PORT LINK INTERFACE BAR 4 CONFIGURATION REGISTER – OFFSET F0h.....	122
8.3.48	NT PORT LINK INTERFACE BAR 4-5 CONFIGURATION REGISTER – OFFSET F4h.....	123
8.3.49	DEVICE SERIAL NUMBER ENHANCED CAPABILITY HEADER REGISTER – OFFSET 100h..	123
8.3.50	DEVICE SERIAL NUMBER LOWER DW REGISTER – OFFSET 104h.....	123
8.3.51	DEVICE SERIAL NUMBER HIGHTER DW REGISTER – OFFSET 108h.....	123
8.3.52	PCI EXPRESS POWER BUDGETING ENHANCED CAPABILITY HEADER REGISTER – OFFSET 138h	124
8.3.53	DATA SELECT REGISTER – OFFSET 13Ch.....	124
8.3.54	POWER BUDGETING DATA REGISTER – OFFSET 140h.....	124
8.3.55	POWER BUDGET CAPABILITY REGISTER – OFFSET 144h.....	124
8.3.56	PCI EXPRESS VIRTUAL CHANNEL ENHANCED CAPABILITY HEADER REGISTER – OFFSET 148h	125
8.3.57	PORT VC CAPABILITY REGISTER 1 – OFFSET 14Ch.....	125
8.3.58	PORT VC CAPABILITY REGISTER 2 – OFFSET 150h.....	125
8.3.59	PORT VC CONTROL REGISTER – OFFSET 154h.....	125
8.3.60	VC STATUS REGISTER – OFFSET 154h.....	126
8.3.61	VC RESOURCE CAPABILITY REGISTER (0) – OFFSET 158h.....	126
8.3.62	VC RESOURCE CONTROL REGISTER (0) – OFFSET 15Ch.....	126
8.3.63	VC RESOURCE STATUS REGISTER (0) – OFFSET 160h.....	127
8.3.64	VC RESOURCE CAPABILITY REGISTER (1) – OFFSET 164h.....	127
8.3.65	VC RESOURCE CONTROL REGISTER (1) – OFFSET 168h.....	127
8.3.66	VC RESOURCE STATUS REGISTER (1) – OFFSET 16Ch.....	128
8.3.67	VC ARBITRATION TABLE REGISTER – OFFSET 188h.....	128
8.3.69	XPIP_CSR 0 REGISTER – OFFSET 844h.....	129
8.3.70	XPIP_CSR 1 REGISTER – OFFSET 848h.....	129
8.3.71	DECODE VGA REGISTER – OFFSET 84Ch.....	129
8.3.72	XPIP_CSR 2 REGISTER – OFFSET 854h.....	129
8.3.73	PHY PARAMETER 2 REGISTER – OFFSET 858h.....	129
8.3.74	PHY PARAMETER 3 REGISTER – OFFSET 85Ch.....	130
8.3.75	XPIP_CSR 3 REGISTER – OFFSET 864h.....	130
8.3.76	XPIP_CSR 5 REGISTER – OFFSET 86Ch.....	130
8.3.77	OPERATION MODE REGISTER – OFFSET 874h (Global).....	131
8.3.78	MAC_CSR REGISTER – OFFSET 890h.....	131
8.3.79	POWER SAVING DISABLE REGISTER – OFFSET 8A4h.....	131
8.3.80	TRANSACTION LAYER CSR REGISTER – OFFSET 8A8h.....	131
8.3.81	REPLAY TIME-OUT COUNTER REGISTER – OFFSET 8ACh.....	132
8.3.82	ACKNOWLEDGE LATENCY TIMER REGISTER – OFFSET 8ACh.....	132
8.3.83	PORT MISC 0 REGISTER – OFFSET 8B0h.....	132

8.3.84	PORT MISC 1 REGISTER – OFFSET 8B4h .....	132
8.3.85	XPIP_CSR 6 REGISTER – OFFSET 8B4h.....	133
8.3.86	XPIP_CSR 7 REGISTER – OFFSET 8B4h.....	133
8.3.87	PORT MISC 2 REGISTER – OFFSET 8B8h .....	133
8.3.88	VENDOR SPECIFIC CAPABILITIES HEADER REGISTER – OFFSET C34h.....	133
8.3.89	VENDOR SPECIFIC HEADER REGISTER – OFFSET C38h.....	133
8.3.90	MEMORY BAR 2 ADDRESS TRANSLATION REGISTER – OFFSET C3Ch.....	134
8.3.91	MEMORY BAR 3 ADDRESS TRANSLATION REGISTER – OFFSET C40h.....	134
8.3.92	MEMORY BAR4 ADDRESS TRANSLATION REGISTER – OFFSET C44h.....	134
8.3.93	MEMORY BAR 5 ADDRESS TRANSLATION REGISTER – OFFSET C48h.....	134
8.3.94	VIRTUAL IF IRQ SET REGISTER – OFFSET C4Ch.....	134
8.3.95	VIRTUAL IF IRQ CLEAR REGISTER – OFFSET C50h.....	134
8.3.96	VIRTUAL IF IRQ MASK SET REGISTER – OFFSET C54h.....	135
8.3.97	VIRTUAL IF IRQ MASK CLEAR REGISTER – OFFSET C58h.....	135
8.3.98	LINK IF IRQ SET REGISTER – OFFSET C5Ch.....	135
8.3.99	LINK IF IRQ CLEAR REGISTER – OFFSET C60h.....	135
8.3.100	LINK IF IRQ MASK SET REGISTER – OFFST C64h.....	135
8.3.101	LINK IF IRQ MASK CLEAR REGISTER – OFFSET C68h.....	135
8.3.102	SCRATCHPAD 0 REGISTER – OFFSET C6Ch.....	135
8.3.103	SCRATCHPAD 1 REGISTER – OFFSET C70h .....	136
8.3.104	SCRATHPAD 2 REGISTER – OFFSET C74h.....	136
8.3.105	SCRATCHPAD 3 REGISTER – OFFSET C78h .....	136
8.3.106	SCRATHPAD 4 REGISTER – OFFSET C7Ch .....	136
8.3.107	SCRATCHPAD 5 REGISTER – OFFSET C80h .....	136
8.3.108	SCRATCHPAD 6 REGISTER – OFFSET C84h .....	136
8.3.109	SCRATCHPAD 7 REGISTER – OFFSTE C88h .....	136
8.3.110	VIRTUAL PORT 32-BITS LTT ENTRY 0-7 – OFFSET D94h to DB0h.....	137
8.3.111	LINK PORT 16-BITS LTT ENTRY 0-31 REGISTER – OFFSET DB4h – DF4h.....	137
8.3.112	FAIL-OVER CSR REGISTER – OFFSET DF4h.....	138
8.3.113	EEPROM_SCRATCHPAD REGISTER – OFFSET FB0h .....	138
8.3.114	PCI EXPRESS ADVANCED ERROR REPORTING ENHANCED CAPABILITY HEADER REGISTER – OFFSET FB4h.....	138
8.3.115	UNCORRECTABLE ERROR STATUS REGISTER – OFFSET FB8h .....	138
8.3.116	UNCORRECTABLE ERROR MASK REGISTER – OFFSET FBCh.....	139
8.3.117	UNCORRECTABLE ERROR SEVERITY REGISTER – OFFSET FC0h .....	139
8.3.118	CORRECTABLE ERROR STATUS REGISTER – OFFSET FC4 h.....	140
8.3.119	CORRECTABLE ERROR MASK REGISTER – OFFSET FC8 h.....	140
8.3.120	ADVANCE ERROR CAPABILITIES AND CONTROL REGISTER – OFFSET FCCh.....	141
8.3.121	HEADER LOG REGISTER – OFFSET From FD0h to FDCh.....	141
8.4	NON TRANSPARENT PORT VIRTUAL INTERFACE CONFIGURATION REGISTERS – NT MODE ONLY 142	
8.4.1	VENDOR ID REGISTER – OFFSET 00h.....	144
8.4.2	DEVICE ID REGISTER – OFFSET 00h.....	144
8.4.3	COMMAND REGISTER – OFFSET 04h.....	144
8.4.5	REVISION ID REGISTER – OFFSET 08h .....	145
8.4.6	CLASS CODE REGISTER – OFFSET 08h.....	145
8.4.7	CACHE LINE REGISTER – OFFSET 0Ch.....	145
8.4.8	PRIMARY LATENCY TIMER REGISTER – OFFSET 0Ch .....	145
8.4.9	HEADER TYPE REGISTER – OFFSET 0Ch.....	146
8.4.10	BAR 0 REGISTER – OFFSET 10h.....	146
8.4.11	BAR 1 REGISTER – OFFSET 14h.....	146
8.4.12	BAR 2 REGISTER – OFFSET 18h.....	146
8.4.13	BAR 3 REGISTER – OFFSET 1Ch.....	146
8.4.14	BAR 4 REGISTER – OFFSET 20h.....	147

8.4.15	BAR 5 REGISTER – OFFSET 24h.....	147
8.4.16	SUBSYSTEM VENDOR ID REGISTER – OFFSET 2Ch.....	147
8.4.17	SUBSYSTEM ID REGISTER – OFFSET 2Ch.....	147
8.4.18	CAPABILITY POINTER REGISTER – OFFSET 34h.....	148
8.4.19	INTERRUPT LINE REGISTER – OFFSET 3Ch.....	148
8.4.20	INTERRUPT PIN REGISTER – OFFSET 3Ch.....	148
8.4.21	POWER MANAGEMENT CAPABILITIES REGISTER – OFFSET 40h.....	148
8.4.22	POWER MANAGEMENT DATA REGISTER – OFFSET 44h.....	148
8.4.23	PPB SUPPORT EXTENSIONS – OFFSET 44h.....	149
8.4.24	DATA REGISTER – OFFSET 44h.....	149
8.4.25	MSI CAPABILITIES REGISTER – OFFSET 48h.....	149
8.4.26	MESSAGE ADDRESS REGISTER – OFFSET 4Ch.....	149
8.4.27	MESSAGE UPPER ADDRESS REGISTER – OFFSET 50h.....	150
8.4.28	MESSAGE DATA REGISTER – OFFSET 54h.....	150
8.4.29	PCI EXPRESS CAPABILITIES REGISTER – OFFSET 68h.....	150
8.4.30	DEVICE CAPABILITIES REGISTER – OFFSET 6Ch.....	150
8.4.31	DEVICE CONTROL REGISTER – OFFSET 70h.....	151
8.4.32	DEVICE STATUS REGISTER – OFFSET 70h.....	151
8.4.33	LINK CAPABILITIES REGISTER – OFFSET 74h.....	152
8.4.34	LINK CONTROL REGISTER – OFFSET 78h.....	152
8.4.35	LINK STATUS REGISTER – OFFSET 78h.....	153
8.4.36	LINK CONTROL REGISTER 2 – OFFSET 98h.....	153
8.4.37	LINK STATUS REGISTER 2 – OFFSET 98h.....	154
8.4.38	SSID/SSVID CAPABILITIES REGISTER – OFFSET A4h.....	154
8.4.39	SUBSYSTEM VENDOR ID REGISTER – OFFSET A8h.....	154
8.4.40	SUBSYSTEM ID REGISTER – OFFSET A8h.....	154
8.4.41	VENDOR SPECIFIC CAPABILITIES REGISTER – OFFSET C8h.....	154
8.4.42	VENDOR SPECIFIC HEADER REGISTER – OFFSET CCh.....	154
8.4.43	NT PORT VIRTUAL INTERFACE BAR 0-1 CONFIGURATION REGISTER – OFFSET D0h.....	155
8.4.44	NT PORT VIRTUAL INTERFACE BAR 2 CONFIGURATION REGISTER – OFFSET D4h.....	155
8.4.45	NT PORT VIRTUAL INTERFACE BAR 2-3 CONFIGURATION REGISTER – OFFSET D8h.....	155
8.4.46	NT PORT VIRTUAL INTERFACE BAR 4 CONFIGURATION REGISTER – OFFSET DCh.....	156
8.4.47	NT PORT VIRTUAL INTERFACE BAR 4/5 CONFIGURATION REGISTER – OFFSET E0h.....	156
8.4.48	DEVICE SERIAL NUMBER ENHANCED CAPABILITY HEADER REGISTER – OFFSET 100h.....	156
8.4.49	DEVICE SERIAL NUMBER LOWER DW REGISTER – OFFSET 104h.....	157
8.4.50	DEVICE SERIAL NUMBER HIGHER DW REGISTER – OFFSET 108h.....	157
8.4.51	VENDOR SPECIFIC ENHANCED CAPABILITY HEADER REGISTER – OFFSET C34h.....	157
8.4.52	VENDOR SPECIFIC HEADER REGISTER – OFFSET C38h.....	157
8.4.53	MEMORY BAR 2 ADDRESS TRANSLATION REGISTER – OFFSET C3Ch.....	157
8.4.54	MEMORY BAR 3 ADDRESS TRANSLATION REGISTER – OFFSET C40h.....	157
8.4.55	MEMORY BAR 4 ADDRESS TRANSLATION REGISTER – OFFSET C44h.....	158
8.4.56	MEMORY BAR 5 ADDRESS TRANSLATION REGISTER – OFFSET C48h.....	158
8.4.57	VIRTUAL IF IRQ SET REGISTER – OFFSET C4Ch.....	158
8.4.58	VIRTUAL IF IRQ CLEAR REGISTER – OFFSET C50h.....	158
8.4.59	VIRTUAL IF IRQ MASK SET REGISTER – OFFSET C54h.....	158
8.4.60	VIRTUAL IF IRQ MASK CLEAR REGISTER – OFFSET C58h.....	158
8.4.61	LINK IF IRQ SET REGISTER – OFFSET C5Ch.....	158
8.4.62	LINK IF IRQ CLEAR REGISTER – OFFSET C60h.....	159
8.4.63	LINK IF IRQ MASK SET REGISTER – OFFSET C64h.....	159
8.4.64	LINK IF IRQ MASK CLEAR REGISTER – OFFSET C68h.....	159
8.4.65	SCRATCHPAD 0 REGISTER – OFFSET C6Ch.....	159
8.4.66	SCRATCHPAD 1 REGISTER – OFFSET C70h.....	159
8.4.67	SCRATCHPAD 2 REGISTER – OFFSET C74h.....	159
8.4.68	SCRATCHPAD 3 REGISTER – OFFSET C78h.....	159

8.4.69	SCRATCHPAD 4 REGISTER – OFFSET C7Ch .....	160
8.4.70	SCRATCHPAD 5 REGISTER – OFFSET C80h .....	160
8.4.71	SCRATCHPAD 6 REGISTER – OFFSET C84h .....	160
8.4.72	SCRATCHPAD 7 REGISTER – OFFSET C88h .....	160
8.4.73	VIRTUAL PORT 32-BITS LTT ENTRY 0-7 – OFFSET D94h to DB0h .....	160
8.4.74	LINK PORT 16-BITS LTT ENTRY 0-31 REGISTER – OFFSET DB4h – DF4h.....	161
8.4.75	FAIL-OVER CSR REGISTER – OFFSET DF4h.....	161
<b>9</b>	<b>CLOCK SCHEME .....</b>	<b>162</b>
<b>10</b>	<b>POWER MANAGEMENT .....</b>	<b>163</b>
<b>11</b>	<b>POWER SEQUENCE .....</b>	<b>164</b>
<b>12</b>	<b>IEEE 1149.1 COMPATIBLE JTAG CONTROLLER.....</b>	<b>165</b>
12.1	INSTRUCTION REGISTER.....	165
12.2	BYPASS REGISTER .....	165
12.3	DEVICE ID REGISTER.....	165
12.4	BOUNDARY SCAN REGISTER.....	166
12.5	JTAG BOUNDARY SCAN REGISTER ORDER.....	166
<b>13</b>	<b>ELECTRICAL AND TIMING SPECIFICATIONS.....</b>	<b>171</b>
13.1	ABSOLUTE MAXIMUM RATINGS .....	171
13.2	DC SPECIFICATIONS .....	171
13.3	AC SPECIFICATIONS .....	171
13.4	OPERATING AMBIENT TEMPERATURE .....	173
13.5	POWER CONSUMPTION.....	173
<b>14</b>	<b>THERMAL DATA .....</b>	<b>174</b>
<b>15</b>	<b>PACKAGE INFORMATION.....</b>	<b>175</b>
<b>16</b>	<b>ORDERING INFORMATION.....</b>	<b>176</b>

## TABLE OF FIGURES

FIGURE 4-1 PI7C9X2G808PR BALL ASSIGNMENT .....	24
FIGURE 6-1 DRIVER OUTPUT WAVEFORM .....	29
FIGURE 6-2 INTELLIGENT ADAPTOR ARCHITECTURE.....	36
FIGURE 7-1 SMBUS ARCHITECTURE IMPLEMENTATION .....	39
FIGURE 7-2 SMBUS BLOCK WRITE COMMAND FORMAT, TO WRITE TO A PI7C9X2G808PR REGISTER WITHOUT PEC .....	40
FIGURE 7-3 SMBUS BLOCK WRITE COMMAND FORMAT, TO WRITE TO A PI7C9X2G808PR REGISTER WITH PEC....	40
FIGURE 7-4 SMBUS BLOCK WRITE TO SET UP READ, AND RESULTING READ THAT RETURNS CFG REGISTER VALUE .....	42
FIGURE 7-5 CSR READ OPERATION USING SMBUS BLOCK READ – BLOCK WRITE PROCESS CALL .....	44
FIGURE 7-6 CSR READ OPERATION USING SMBUS BLOCK READ – BLOCK WRITE PROCESS CALL WITH PEC .....	44
FIGURE 7-7 STANDARD DEVICES TO I <sup>2</sup> C BUS CONNECTION BLOCK DIAGRAM.....	45
FIGURE 7-8 I <sup>2</sup> C WRITE PACKET .....	47
FIGURE 7-9 I <sup>2</sup> C REGISTER WRITE ACCESS EXAMPLE .....	47
FIGURE 7-10 I <sup>2</sup> C WRITE COMMAND PACKET EXAMPLE .....	48
FIGURE 7-11 I <sup>2</sup> C READ COMMAND PACKET .....	49
FIGURE 7-12 I <sup>2</sup> C REGISTER READ ACCESS EXAMPLE .....	50
FIGURE 7-13 I <sup>2</sup> C READ COMMAND PACKET .....	50
FIGURE 11-1 INITIAL POWER-UP SEQUENCE .....	164
FIGURE 15-1 PACKAGE OUTLINE DRAWING .....	175
FIGURE 15-2 PART MARKING .....	175

## LIST OF TABLES

TABLE 6-1 RECEIVER DETECTION THRESHOLD SETTINGS .....	27
TABLE 6-2 RECEIVER SIGNAL DETECT THRESHOLD .....	28
TABLE 6-3 RECEIVER EQUALIZATION SETTINGS .....	28
TABLE 6-4 TRANSMITTER SWING SETTINGS .....	28
TABLE 6-5 DRIVE AMPLITUDE BASE LEVEL REGISTERS .....	29
TABLE 6-6 DRIVE AMPLITUDE BASE LEVEL SETTINGS .....	29
TABLE 6-7 DRIVE DE-EMPHASIS BASE LEVEL REGISTER .....	30
TABLE 6-8 DRIVE DE-EMPHASIS BASE LEVEL SETTINGS .....	30
TABLE 6-9 SUMMARY OF PCI EXPRESS ORDERING RULES .....	33
TABLE 7-1 SMBUS ADDRESS PIN CONFIGURATION .....	39
TABLE 7-2 BYTES FOR SMBUS BLOCK WRITE .....	40
TABLE 7-3 SAMPLE SMBUS BLOCK WRITE BYTE SEQUENCE .....	41
TABLE 7-4 BYTES FOR SMBUS BLOCK READ .....	42
TABLE 7-5 SMBUS BLOCK WRITE PORTION .....	43
TABLE 7-6 SMBUS BLOCK READ PORTION .....	43
TABLE 7-7 SMBUS READ COMMAND FOLLOWING REPEAT START FROM MASTER .....	43
TABLE 7-8 SMBUS RETURN BYTES .....	43
TABLE 7-9 COMMAND FORMAT FOR SMBUS BLOCK READ .....	44
TABLE 7-10 I <sup>2</sup> C ADDRESS PIN CONFIGURATION .....	45
TABLE 7-11 I <sup>2</sup> C REGISTER WRITE ACCESS .....	46
TABLE 7-12 I <sup>2</sup> C COMMAND FORMAT FOR WRITE ACCESS .....	46
TABLE 7-13 I <sup>2</sup> C COMMAND FORMAT FOR READ ACCESS .....	48
TABLE 8-1 REGISTER TYPES .....	51
TABLE 8-2 REGISTER ARRAY LAYOUT FOR VC ARBITRATION .....	76
TABLE 8-3 TABLE ENTRY SIZE IN 4 BITS .....	77
TABLE 8-4 REGISTER ARRAY LAYOUT FOR VC ARBITRATION .....	128
TABLE 8-5 TABLE ENTRY SIZE IN 4 BITS .....	128
TABLE 8-6 VIRTUAL PORT 32-BITS LTT ENTRY 0-7 REGISTER LOCATIONS .....	137
TABLE 8-7 VIRTUAL PORT 32-BITS LTT ENTRY <sub>N</sub> (N=0 THROUGH 7) .....	137
TABLE 8-8 LINK PORT 16-BITS LTT ENTRY 0-31 REGISTER LOCATIONS .....	137
TABLE 8-9 LINK PORT 16-BITS LTT ENTRY <sub>N_M</sub> (N_M 0-1 TO 30-31) .....	137
TABLE 8-10 VIRTUAL PORT 32-BITS LTT ENTRY 0-7 REGISTER LOCATIONS .....	160
TABLE 8-11 VIRTUAL PORT 32-BITS LTT ENTRY <sub>N</sub> (N=0 THROUGH 7) .....	160
TABLE 8-12 LINK PORT 16-BITS LTT ENTRY 0-31 REGISTER LOCATIONS .....	161
TABLE 8-13 LINK PORT 16-BITS LTT ENTRY <sub>N_M</sub> (N_M 0-1 TO 30-31) .....	161
TABLE 9-1 DC ELECTRICAL CHARACTERISTICS .....	162
TABLE 12-1 INSTRUCTION REGISTER CODES .....	165
TABLE 12-2 JTAG DEVICE ID REGISTER .....	165
TABLE 12-3 JTAG BOUNDARY SCAN REGISTER DEFINITION .....	166
TABLE 13-1 ABSOLUTE MAXIMUM RATINGS .....	171
TABLE 13-2 DC ELECTRICAL CHARACTERISTICS .....	171
TABLE 13-3 PCI EXPRESS INTERFACE - DIFFERENTIAL TRANSMITTER (TX) OUTPUT (5.0 GBPS) CHARACTERISTICS .....	171
TABLE 13-4 PCI EXPRESS INTERFACE - DIFFERENTIAL TRANSMITTER (TX) OUTPUT (2.5 GBPS) CHARACTERISTICS .....	172
TABLE 13-5 PCI EXPRESS INTERFACE - DIFFERENTIAL RECEIVER (RX) INPUT (5.0 GBPS) CHARACTERISTICS .....	172
TABLE 13-6 PCI EXPRESS INTERFACE - DIFFERENTIAL RECEIVER (RX) INPUT (2.5 GBPS) CHARACTERISTICS .....	173
TABLE 13-7 OPERATING AMBIENT TEMPERATURE .....	173
TABLE 13-8 POWER CONSUMPTION .....	173
TABLE 14-1 THERMAL DATA .....	174

## 1 FEATURES

- 8-lane PCI Express Gen 2 Switch with 8 PCI Express ports
- Supports “Cut-through”(Default) as well as “Store and Forward” mode for packet switching
- 150 ns typical latency for packet routed through Switch without blocking
- Supports Transparent and Non-Transparent Modes
- Strapped pins configurable with optional EEPROM, SMBus or I2C Bus
- SMBus interface support
- I2C Slave interface support
- Compliant with System Management (SM) Bus, Version 2.0
- Compliant with I2C Bus Specification, Version 2.1
- Compliant with *PCI Express Base Specification Revision 2.1*
- Compliant with *PCI Express CEM Specification Revision 2.0*
- Compliant with *PCI-to-PCI Bridge Architecture Specification Revision 1.2*
- Compliant with *Advanced Configuration Power Interface (ACPI) Specification*
- Reliability, Availability and Serviceability
  - Supports Data Poisoning and End-to-End CRC
  - Advanced Error Reporting and Logging
- Advanced Power Saving
  - Empty downstream ports are set to idle state to minimize power consumption
- Link Power Management
  - Supports L0, L0s, L1, L2, L2/L3<sub>Ready</sub> and L3 link power states
  - Active state power management for L0s and L1 states
- Device State Power Management
  - Supports D0, D3<sub>Hot</sub> and D3<sub>Cold</sub> device power states
- Port Arbitration: Round Robin (RR), Weighted RR and Time-based Weighted RR
- Extended Virtual Channel capability
  - Two Virtual Channels (VC) and Eight Traffic Class (TC) support
  - Disabled VCs’ buffer is assigned to enabled VCs for resource sharing
  - Independent TC/VC mapping for each port
  - Provides VC arbitration selections: Strict Priority, Round Robin (RR) and Programmable Weighted RR
- Supports Isochronous Traffic
  - Isochronous traffic class mapped to VC1 only
  - Strict time based credit policing
- Supports up to 512-byte maximum payload size
- Programmable driver current and de-emphasis level at each individual port
- Support Access Control Service (ACS)
- Support Address Translation (AT) packet for SR-IOV application
- Support Alternative Routing ID Interpretation (ARI)
- Support Multicast
- Support Serial Hot Plug Controller
- Low Power Dissipation: 1.23W typical in L0 normal mode
- Industrial Temperature Range -40° to 85°C
- Totally Lead-Free & Fully RoHS Compliant (Notes 1 & 2)
- Halogen and Antimony Free. “Green” Device (Note 3)
- For automotive applications requiring specific change control (i.e. parts qualified to AEC-Q100/101/200, PPAP capable, and manufactured in IATF 16949 certified facilities), please [contact us](#) or your local Diodes representative.
- <https://www.diodes.com/quality/product-definitions/>
- 196-pin LBGA 15mm x 15mm package (ULA)

### Notes:

1. No purposely added lead. Fully EU Directive 2002/95/EC (RoHS), 2011/65/EU (RoHS 2) & 2015/863/EU (RoHS 3) compliant.
2. See <https://www.diodes.com/quality/lead-free/> for more information about Diodes Incorporated’s definitions of Halogen- and Antimony-free, “Green” and Lead-free.
3. Halogen- and Antimony-free “Green” products are defined as those which contain <900ppm bromine, <900ppm chlorine (<1500ppm total Br + Cl) and <1000ppm antimony compounds.



## 2 GENERAL DESCRIPTION

Similar to the role of PCI/PCIX Bridge in PCI/PCIX bus architecture, the function of PCI Express (PCIE) Switch is to expand the connectivity to allow more end devices to be reached by host controllers in PCIE serial interconnect architecture. The 8-lane PCIE Switch is in 8-port type configuration. It provides users the flexibility to expand or fan-out the PCI Express lanes based on their application needs.

In the PCI Express Architecture, the PCIE Switch forwards posted and non-posted requests, and completion packets in either downstream or upstream direction concurrently as if a virtual PCI Bridge is in operation on each port. By visualizing the port as a virtual Bridge, the Switch can be logically viewed as two-level cascaded multiple virtual PCI-to-PCI Bridges, where one upstream-port Bridge sits on all downstream-port Bridges. Similar to a PCI Bridge during enumeration, each port is given a unique bus number, device number, and function number by the initiating software. The bus number, device number, and function number are combined to form a destination ID for each specific port. In addition to that, the memory-map and IO address ranges are exclusively allocated to each port as well. After the software enumeration is finished, the packets are routed to the dedicated port based on the embedded address or destination ID. To ensure the packet integrity during forwarding, the Switch is not allowed to split the packets to multiple small packets or merge the received packets into a large transmit packet. Also, the IDs of the requesters and completers are kept unchanged along the path between ingress and egress port.

The Switch employs the architecture of Combined Input and Output Queue (CIOQ) in implementation. The main reason for choosing CIOQ is that the required memory bandwidth of input queue equals to the bandwidth of ingress port rather than increasing proportionally with port numbers as an output queue Switch does. The CIOQ at each ingress port contains separate dedicated queues to store packets. The packets are arbitrated to the egress port based on the PCIe transaction-ordering rule. For the packets without ordering information, they are permitted to pass over each other in case that the addressed egress port is available to accept them. As to the packets required to follow the ordering rule, the Head-Of-Line (HOL) issue becomes unavoidable for packets destined to different egress ports since the operation of producer-consumer model has to be retained; otherwise the system might occur hang-up problem. On the other hand, the Switch places replay buffer at each egress port to defer the packets before sending it out. This can assure the maximum throughput being achieved and therefore the Switch works efficiently. Another advantage of implementing CIOQ in PCIE Switch is that the credit announcement to the counterpart is simplified and streamlined because of the credit-based flow control protocol. The protocol requires that each ingress port maintains the credits independently without checking other ports' credit availability, which is otherwise required by pure output queue architecture.

The Switch supports two virtual channels (VC0, VC1) and eight traffic classes (TC0 ~ TC7) at each port. The ingress port independently assigns packets into the preferred virtual channel while the egress port outputs the packet based on the predefined port and VC arbitration algorithm. For instance, the isochronous packet is given a special traffic class number other than TC0 and mapped into VC1 accordingly. By employing the strict time based credit policy for port arbitration and assigning higher priority to VC1 than VC0, the Switch can therefore guarantee the time-sensitive packet is not blocked by regular traffic to assure the quality of service. In addition, some data-centric applications only carry TC0/VC0 traffic. As a result, there are no packets that would consume VC1 bandwidth. In order to improve the efficiency of buffer usage, the unused VC1 queues can be reassigned to VC0 and enable each of the ingress ports to handle more data traffic bursts. This virtual channel resource relocation feature enhances the performance of the PCIE Switch further.

The Switch provides the advanced feature of Access Control Service (ACS). This feature regulates which components are allowed to communicate with each other within the PCIe multiple-point fabric, and allows the system to have more control over packet routing in the Switch. As a result, peer-to-peer traffic can be facilitated more accurately and efficiently. When the system also implements Address Translation Service (ATS), the peer-to-peer requests with translated address can be routed directly by enabling the corresponding option in ACS to avoid possible performance bottleneck associated with re-direction, which introduces extra latency and may increase link and RC congestion.

Non-Transparent (NT) Bridging is supported by the packet switch. The NT bridge allows two separate Hosts to be connected together. One single port of the packet switch can be configured to operate in NT mode. While the port is in NT mode, the packet switch allows the isolation of address spaces, and the packet switch acts as an endpoint to the Host to allow inter-processor communication. NT mode is enabled and disabled by toggling the NT\_EN\_L strapping pin.

### 3 PIN DESCRIPTION

#### 3.1 PCI EXPRESS INTERFACE SIGNALS (40 BALLS)

NAME	PIN	TYPE	DESCRIPTION
REFCLKP REFCLKN	N8 P8	I	<b>Reference Clock Input Pairs:</b> Connect to 100MHz differential clock.  The input clock signals must be delivered to the clock buffer cell through an AC-coupled interface so that only the AC information of the clock is received, converted, and buffered. It is recommended that a 0.1uF be used in the AC-coupling.
PERP[7:0]	A3,A5,A10,A12, P12,P10,P5,P3	I	<b>PCI Express Data Serial Input Pairs:</b> Differential data receive signals in eight ports.  Please refer to Section 5 for Mapping of the Lanes to transmission and receive pairs and configuration of Port-Lane.
PERN[7:0]	B3,B5,B10,B12, N12,N10,N5,N3	I	
PETP[7:0]	A4,A6,A9,A11, P11,P9,P6,P4	O	<b>PCI Express Data Serial Output Pairs:</b> Differential data transmit signals in eight ports.  Please refer to Section 5 for Mapping of the Lanes to transmission and receive pairs and configuration of Port-Lane.
PETN[7:0]	B4,B6,B9,B11, N11,N9,N6,N4	O	
PERST_L	H13	I	<b>System Reset (Active LOW):</b> When PERST_L is asserted, the internal states of whole chip except sticky logics are initialized.  Please refer to Table 11-2 for PERST_L Spec.
REXT[1:0]	B8,P7	I	<b>External Reference Resistor:</b> Connect an external resistor (1.43K Ohm +/- 1%) to REXT_GND to provide a reference to both the bias currents and impedance calibration circuitry.
REXT_GND[1:0]	A8,N7	I	<b>External Reference Resistor Ground:</b> Connect to an external resistor to REXT.
NT_RESET_L	L13	O	<b>Propagate Reset in NT mode:</b> Pulse width is 1us.

#### 3.2 PORT SPECIFIC SIGNALS (21 BALLS)

NAME	PIN	TYPE	DESCRIPTION
LNKSTS[7:0]	C2,A14,B14,B1, L12,L14, M13,P14	O	<b>Link Status:</b> These signals indicate the link status of each lane. When continuously deasserts, the device is in the condition of link down. When continuously asserts, the link is up and operates at 5GT/s. When blinking, asserts and deasserts with 0.5-second intervals, the link is up and operates at 2.5GT/s.  LNKSTS[x] is correspondent to Lane x, where x=0-7.  Note: In the case where the downstream port or upstream port is configured to more than x1 lane, all associated lanes' LINKSTS signals of the port behave identically regardless of the actual link mode. For example, if the port is configured as a x4 link width. All four LINKSTS of the lanes used by the port turn on/off or flash synchronously even if the port is currently operating in x1, x2 or x4 link state.
UPS_PORTSEL[3:0]	G2,H2,F1,F3	I	<b>Upstream Port Selection:</b> These signals decide which port will be the upstream port. These pins must be pull-up or pull-down by external resistors.  Please refer to Section 5 for Port-Lane Mapping.  These strapping pins have no built-in internal resistors and can not be left NC. These pins require the external 5.1K-ohm pull-up resistors or 330-ohm pull-down resistors.

NAME	PIN	TYPE	DESCRIPTION
PORTCFG[1:0]	B2,A1	I	<p><b>Port-Lane Configuration:</b> These signals decide Port-Lane configuration.</p> <p>Please refer to Section 5 for Port-Lane Mapping.</p> <p>These strapping pins have no built-in internal resistors and can not be left NC. These pins require the external 5.1K-ohm pull-up resistors or 330-ohm pull-down resistors.</p>
NT_EN_L	H12	I	<p><b>NT Mode Enable:</b> When tied low, NT mode is enabled. When tied high, NT mode is disabled. This strapping pin has no built-in internal resistor and cannot be left NC. The pin requires an external 5.1K-ohm pull-up resistor or 330-ohm pull-down resistor.</p>
NT_P2P_EN_L	G1	I	<p><b>NT PCI-to-PCI Bridge Mode Enable:</b> When tied low, NT PCI-to-PCI bridge mode is enabled. When tied high, NT PCI-to-PCI bridge mode is disabled. This pin has internal pull-up. If no board trace is connected to this pin, the internal pull-up resistor of this pin is enough. However, if pin is connected to a board trace and not driven, it is recommended that an external 5.1K-ohm pull-up resistor be used.</p>
NT_PORTSEL[3:0]	M3,K3,J2,J3	I	<p><b>Upstream NT Port Selection:</b> These signals decide which port will be the upstream NT port. These pins must be pull-up or pull-down by external resistors.</p> <p>Please refer to Section 5 for Port-Lane Mapping.</p> <p>These strapping pins have no built-in internal resistors and can not be left NC. These pins require the external 5.1K-ohm pull-up resistors or 330-ohm pull-down resistors.</p>
CFG_TIMER_EN_L	C1	I	<p><b>CFG Timer Enable:</b> When tied high, TS pkts always advertises support for GENII data rate and autonomous change. When tied low, if the LTSSM fails during the Configuration state, TS pkts only advertises GENI data rate and no autonomous change support in next time the LTSSM exists the Detect state. If the LTSSM fails continuously in Configuration state, the LTSSM continues to alternate between GENI and GENII advertisement every time it exists the Detect state.</p> <p>This pin has internal pull-up. If no board trace is connected to this pin, the internal pull-up resistor of this pin is enough. However, if pin is connected to a board trace and not driven, it is recommended that an external 5.1K-ohm pull-up resistor be used.</p>

### 3.3 EEPROM and SMBUS/I2C SIGNALS (10 BALLS)

NAME	PIN	TYPE	DESCRIPTION
EECK	J14	I/O	<b>EEPROM Clock:</b> Clock signal to 4-wire EEPROM interface.
EEDI	K14	O	<b>EEPROM Data Input:</b> Pericom 2G808PR outputs data to the Data Input pin of Serial EEPROM.
EEDO	H14	I	<b>EEPROM Data Output:</b> Pericom 2G808PR inputs data from the Data Output pin of Serial EEPROM.
EECS_L	J13	I/O	<p><b>EEPROM Chip Select (Active Low):</b> Pericom 2G808PR asserts this signal to enable Serial EEPROM.</p> <p><b>EEPROM Bypass Mode (EEPROM_BYPASS):</b> During system initialization, EECS_L acts as the EEPROM_BYPASS pin. When tied high, eeprom function is disabled. When tied low, eeprom function is enabled. This pin has internal pull-up resistor. If no board trace is connected to this pin, the internal pull-up resistor of this pin is enough. However, if pin is connected to a board trace and not driven, it is recommended that an external 5.1K-ohm pull-up resistor be used.</p>
SCL_I2C	F14	OD	<b>SMBUS/I2C Serial Clock:</b> System management or I2C Bus Clock. This pin requires an external pull-up resistor.
SDA_I2C	F12	OD	<b>SMBUS/I2C Serial Data:</b> Bi-Directional System Management or I2C Bus Data. This pin requires an external pull-up resistor.

NAME	PIN	TYPE	DESCRIPTION
I2C_ADDR[2:0]	G14,F11,G13	I	<b>SMBUS/I2C Slave Address Bit [2:0]:</b> These pins are used to configure the value of the three least significant bits of the PI7C2G808PR 7-bit Slave address. These pins require the external 5.1K-ohm pull-up resistors or 330-ohm pull-down resistors.
SMBUS_EN_L	L1	I	<b>System Manage Bus Enable:</b> Select either SMBUS or I2C protocol. When tied high, I2C protocol is selected. When tied low, SMBUS protocol is chosen. This pin has internal pull-up resistor. If no board trace is connected to this pin, the internal pull-up resistor of this pin is enough. However, if pin is connected to a board trace and not driven, it is recommended that an external 5.1K-ohm pull-up resistor be used.

### 3.4 MISCELLANEOUS SIGNALS (45 BALLS)

NAME	PIN	TYPE	DESCRIPTION
SHCL_I2C	F13	OD	<b>I2C Clock Signal of Serial Hot Plug Controller:</b> It is connected to SCL pin of all I2C IO expanders. This pin requires an external 5.1K-ohm pull-up resistor.
SHDA_I2C	E14	OD	<b>I2C Data Signal of Serial Hot Plug Controller:</b> It is connected to SDA pin of all I2C IO expanders. This pin requires an external 5.1K-ohm pull-up resistor.
SHPCINT_L	C14	I	<b>Interrupt Input (Active Low) of Serial Hot Plug Controller:</b> It is connected to INT# output pin of all I2C IO expanders. When asserted, it notifies Hot Plug Controller to access the port registers of all I/O expanders for touching changed status to de-assert INT#. This pin is set to '1' by default.
GPIO[30,29,16:0]	A2,D3,K12,N2, M2,L3,P1,P2,M1, K1,H1,J1,J4,F2, E1,E2, E3,D1,D2	I/O	<b>General Purpose Input and Output:</b> These nineteen general-purpose pins are programmed as either input-only or bi-directional pins by writing the GPIO output enable control register.
FATAL_ERR_L	B13	O	<b>Fatal Error Output:</b> It is asserted low when a Fatal error is detected.
INTA_L	J12	OD	<b>Interrupt Output Enable:</b> When tied low, it indicates that one or more of the following events/errors are detected: Hot Plug events, Link State events, General-Purpose Input Interrupt events, Device-Specific errors, Device-Specific NT Port Link Interface errors and events, NT-Virtual Doorbell events or NT-Link Doorbell events.
DEBUG_SEL[1:0]	L2,J11	I	<b>Test Only</b> Must be pulled up by an external 5.1K-ohm resistor.
FAST_MODE_L	C3	I	<b>Test Only</b> Must be pulled up by an external 5.1K-ohm resistor.
PROBE_MODE_L	K13	I	<b>Test Only</b> Must be pulled up by an external 5.1K-ohm resistor.
SERDES_MODE_EN_L	C4	I	<b>Test Only</b> Must be pulled up by an external 5.1K-ohm resistor.
TESTMODE[3:0]	N13,M14,N14, P13	I	<b>Test Only</b> Must be pulled up by an external 5.1K-ohm resistor.
PLL_BYPASS_L	M12	I	<b>Test Only</b> Must be pulled up by an external 5.1K-ohm resistor.
TEST	M4	I	<b>Test Only</b> Must be pulled up by an external 5.1K-ohm resistor.
NC	A7,A13,B7,C7, C12,D13,F4,K2, M8,N1		<b>No Connection:</b> leaves these pins floating.

### 3.5 JTAG BOUNDARY SCAN SIGNALS (5 Balls)

NAME	PIN	TYPE	DESCRIPTION
TCK	E13	I	<b>Test Clock:</b> Used to clock state information and data into and out of the chip during boundary scan. When JTAG boundary scan function is not implemented, this pin should be left open (NC).

NAME	PIN	TYPE	DESCRIPTION
TMS	D14	I	<b>Test Mode Select:</b> Used to control the state of the Test Access Port controller. When JTAG boundary scan function is not implemented, this pin should be pulled low through a 330-Ohm pull-down resistor.
TDO	E12	O	<b>Test Data Output:</b> Used (in conjunction with TCK) to shift data out of the Test Access Port (TAP) in a serial bit stream. When JTAG boundary scan function is not implemented, this pin should be left open (NC).
TDI	D12	I	<b>Test Data Input:</b> Used (in conjunction with TCK) to shift data and instructions into the TAP in a serial bit stream. When JTAG boundary scan function is not implemented, this pin should be left open (NC).
TRST_L	C13	I	<b>Test Reset (Active LOW):</b> Active LOW signal to reset the TAP controller into an initialized state. When JTAG boundary scan function is not implemented, this pin should be pulled low through a 330-Ohm pull-down resistor.

### 3.6 POWER PINS (75 BALLS)

NAME	PIN	TYPE	DESCRIPTION
VDDC	D5,D6,D9,D10,E4,E11,G4,G11,H4,H11,K4,K11,L5,L6,L9,L10	P	<b>VDDC Supply (1.0V):</b> Used as digital core power pins.
VDDR	D4,D11,L4,L11	P	<b>VDDR Supply (2.5V):</b> Used as digital I/O power pins.
AVDD	D7,D8,L7,L8	P	<b>AVDD Supply (1.0V):</b> Used as PCI Express analog power pins.
AVDDH	C8,G3,G12,M7	P	<b>AVDDH Supply (2.5V):</b> Used as PCI Express analog high voltage power pins.
VSS	C5,C6,C9,C10,C11,E5,E6,E7,E8,E9,E10,F5,F6,F7,F8,F9,F10,G5,G6,G7,G8,G9,G10,H3,H5,H6,H7,H8,H9,H10,J5,J6,J7,J8,J9,J10,K5,K6,K7,K8,K9,K10,M5,M6,M9,M10,M11	P	<b>Ground:</b> Used as ground pins.

## 4 PIN DESCRIPTION

### 4.1 PIN LIST of 196-BALL LPGA

PIN	NAME	PIN	NAME	PIN	NAME	PIN	NAME
A1	PORTCFG[0]	D8	AVDD	H1	GPIO[8]	L8	AVDD
A2	GPIO[30]	D9	VDDC	H2	UPS_PORTSEL[2]	L9	VDDC
A3	PERP[7]	D10	VDDC	H3	VSS	L10	VDDC
A4	PETP[7]	D11	VDDR	H4	VDDC	L11	VDDR
A5	PERP[6]	D12	TDI	H5	VSS	L12	LNKSTS[3]
A6	PETP[6]	D13	NC	H6	VSS	L13	NT_PERST L
A7	NC	D14	TMS	H7	VSS	L14	LNKSTS[2]
A8	REXT_GND[1]	E1	GPIO[4]	H8	VSS	M1	GPIO[10]
A9	PETP[5]	E2	GPIO[3]	H9	VSS	M2	GPIO[14]
A10	PERP[5]	E3	GPIO[2]	H10	VSS	M3	NT_PORTSEL[3]
A11	PETP[4]	E4	VDDC	H11	VDDC	M4	TEST
A12	PERP[4]	E5	VSS	H12	NT_EN L	M5	VSS
A13	NC	E6	VSS	H13	PERST L	M6	VSS
A14	LNKSTS[6]	E7	VSS	H14	EEDO	M7	AVDDH
B1	LNKSTS[4]	E8	VSS	J1	GPIO[7]	M8	NC
B2	PORTCFG[1]	E9	VSS	J2	NT_PORTSEL[1]	M9	VSS
B3	PERN[7]	E10	VSS	J3	NT_PORTSEL[0]	M10	VSS
B4	PETN[7]	E11	VDDC	J4	GPIO[6]	M11	VSS
B5	PERN[6]	E12	TDO	J5	VSS	M12	PLL_BYPASS L
B6	PETN[6]	E13	TCK	J6	VSS	M13	LNKSTS[1]
B7	NC	E14	SHDA I2C	J7	VSS	M14	TESTMODE[2]
B8	REXT[1]	F1	UPS_PORTSEL[1]	J8	VSS	N1	NC
B9	PETN[5]	F2	GPIO[5]	J9	VSS	N2	GPIO[15]
B10	PERN[5]	F3	UPS_PORTSEL[0]	J10	VSS	N3	PERN[0]
B11	PETN[4]	F4	NC	J11	DEBUG_SEL[0]	N4	PETN[0]
B12	PERN[4]	F5	VSS	J12	INTA L	N5	PERN[1]
B13	FATAL_ERR L	F6	VSS	J13	EECS L	N6	PETN[1]
B14	LNKSTS[5]	F7	VSS	J14	EECK	N7	REXT_GND[0]
C1	CFG_TIMER_EN L	F8	VSS	K1	GPIO[9]	N8	REFCLKP
C2	LNKSTS[7]	F9	VSS	K2	NC	N9	PETN[2]
C3	FAST_MODE L	F10	VSS	K3	NT_PORTSEL[2]	N10	PERN[2]
C4	SERDES_MODE_EN L	F11	I2C_ADDR[1]	K4	VDDC	N11	PETN[3]
C5	VSS	F12	SDA I2C	K5	VSS	N12	PERN[3]
C6	VSS	F13	SHCL I2C	K6	VSS	N13	TESTMODE[3]
C7	NC	F14	SCL I2C	K7	VSS	N14	TESTMODE[1]
C8	AVDDH	G1	NT_P2P_EN L	K8	VSS	P1	GPIO[12]
C9	VSS	G2	UPS_PORTSEL[3]	K9	VSS	P2	GPIO[11]
C10	VSS	G3	AVDDH	K10	VSS	P3	PERP[0]
C11	VSS	G4	VDDC	K11	VDDC	P4	PETP[0]
C12	NC	G5	VSS	K12	GPIO[16]	P5	PERP[1]
C13	TRST L	G6	VSS	K13	PROBE_MODE L	P6	PETP[1]
C14	SHPCINT L	G7	VSS	K14	EEDI	P7	REXT[0]
D1	GPIO[1]	G8	VSS	L1	SMBUS_EN L	P8	REFCLKN
D2	GPIO[0]	G9	VSS	L2	DEBUG_SEL[1]	P9	PETP[2]
D3	GPIO[29]	G10	VSS	L3	GPIO[13]	P10	PERP[2]
D4	VDDR	G11	VDDC	L4	VDDR	P11	PETP[3]
D5	VDDC	G12	AVDDH	L5	VDDC	P12	PERP[3]
D6	VDDC	G13	I2C_ADDR[0]	L6	VDDC	P13	TESTMODE[0]
D7	AVDD	G14	I2C_ADDR[2]	L7	AVDD	P14	LNKSTS[0]

	1	2	3	4	5	6	7	8	9	10	11	12	13	14	
A	PORTCFG[0]	GPIO[30]	PERP[7]	PETP[7]	PERP[6]	PETP[6]	NC	REXT_GND[1]	PETP[5]	PERP[5]	PETP[4]	PERP[4]	NC	LNKSTS[6]	A
B	LNKSTS[4]	PORTCFG[1]	PERN[7]	PETN[7]	PERN[6]	PETN[6]	NC	REXT[1]	PETN[5]	PERN[5]	PETN[4]	PERN[4]	FATAL_ERR_L	LNKSTS[5]	B
C	CFG_TIMER_EN_L	LNKSTS[7]	FAST_MODE_L	SERDES_MODE_EN_L	VSS	VSS	NC	AVDDH	VSS	VSS	VSS	NC	TRST_L	SHPCINT_L	C
D	GPIO[1]	GPIO[0]	GPIO[29]	VDDR	VDDC	VDDC	AVDD	AVDD	VDDC	VDDC	VDDR	TDI	NC	TMS	D
E	GPIO[4]	GPIO[3]	GPIO[2]	VDDC	VSS	VSS	VSS	VSS	VSS	VSS	VDDC	TDO	TCK	SHDA_I2C	E
F	UPS_PORTSEL[1]	GPIO[5]	UPS_PORTSEL[0]	NC	VSS	VSS	VSS	VSS	VSS	VSS	I2C_ADDR[1]	SDA_I2C	SHCL_I2C	SCL_I2C	F
G	NT_P2PEN_L	UPS_PORTSEL[3]	AVDDH	VDDC	VSS	VSS	VSS	VSS	VSS	VSS	VDDC	AVDDH	I2C_ADDR[0]	I2C_ADDR[2]	G
H	GPIO[8]	UPS_PORTSEL[2]	VSS	VDDC	VSS	VSS	VSS	VSS	VSS	VSS	VDDC	NT_EN_L	PERST_L	EEDO	H
J	GPIO[7]	NT_PORTSEL[1]	NT_PORTSEL[0]	GPIO[6]	VSS	VSS	VSS	VSS	VSS	VSS	DEBUG_SEL[0]	INTA_L	EECS_L	EECK	J
K	GPIO[9]	NC	NT_PORTSEL[2]	VDDC	VSS	VSS	VSS	VSS	VSS	VSS	VDDC	GPIO[16]	PROBE_MODE_L	EEDI	K
L	SMBUS_EN_L	DEBUG_SEL[1]	GPIO[13]	VDDR	VDDC	VDDC	AVDD	AVDD	VDDC	VDDC	VDDR	LNKSTS[3]	NT_RES_ET_L	LNKSTS[2]	L
M	GPIO[10]	GPIO[14]	NT_PORTSEL[3]	TEST	VSS	VSS	AVDDH	NC	VSS	VSS	VSS	PLL_BY_PASS_L	LNKSTS[1]	TESTMODE[2]	M
N	NC	GPIO[15]	PERN[0]	PETN[0]	PERN[1]	PETN[1]	REXT_GND[0]	REFCLK_P	PETN[2]	PERN[2]	PETN[3]	PERN[3]	TESTMODE[3]	TESTMODE[1]	N
P	GPIO[12]	GPIO[11]	PERP[0]	PETP[0]	PERP[1]	PETP[1]	REXT[0]	REFCLK_N	PETP[2]	PERP[2]	PETP[3]	PERP[3]	TESTMODE[0]	LNKSTS[0]	P

**Figure 4-1 PI7C9X2G808PR Ball Assignment**



## 5 MODE SELECTION AND PORT-LANE MAPPING

### 5.1 MODE SELECTION

PI7C9X2G808PR can be configured into 8 Port-8 Lane, 5 Port-8 Lane and 2 Port-8 Lane modes by setting PORTCFG[1:0] pins.

PORTCFG[1]	PORTCFG[0]	Functional Mode
0	0	8Port-8Lane Configuration
0	1	5Port-8Lane Configuration
1	0	2Port-8Lane Configuration
1	1	Reserved

### 5.2 LANE MAPPING

The table below shows the mapping of the lanes to the transmission and receives pairs.

Lane	TX Pair	RX Pair
Lane 0	PETP[0]PETN[0]	PERP[0]PERN[0]
Lane 1	PETP[1]PETN[1]	PERP[1]PERN[1]
Lane 2	PTTP[2]PETN[2]	PERP[2]PERN[2]
Lane 3	PETP[3]PETN[3]	PERP[3]PERN[3]
Lane 4	PETP[4]PETN[4]	PERP[4]PERN[4]
Lane 5	PTTP[5]PETN[5]	PERP[5]PERN[5]
Lane 6	PETP[6]PETN[6]	PERP[6]PERN[6]
Lane 7	PETP[7]PETN[7]	PERP[7]PERN[7]

### 5.3 PORT-LANE MAPPING

The table below shows the mapping of the lanes to ports in different functional modes via UPS\_PORTSEL[3:0] settings.

UPS_PORTSEL[3:0] = 0	Functional Mode		
	808	508	208
Lane 0	P0	P0	P0
Lane 1	P4	P0	P0
Lane 2	P6	P0	P0
Lane 3	P8	P0	P0
Lane 4	P1	P1	P1
Lane 5	P5	P5	P1
Lane 6	P7	P7	P1
Lane 7	P9	P9	P1

Notes:

P0: upstream port

1) P1, P4~P9: downstream ports

The table below shows all acceptable values of UPS\_PORTSEL[3:0] and NT\_PORTSEL[3:0] in different functional mode.

Acceptable Values	UPS_PORTSEL[3:0]	NT_PORTSEL[3:0]
808 Mode	0~1 and 4~9 are allowed	0~1 and 4~9 are allowed
508 Mode	0 is allowed	1,5,7,9 are allowed
208 Mode	0 and 1 are allowed	0 and 1 are allowed

Notes:

- 2) By default, Upstream port is on P0, and NT port is on P1 if NT mode is enabled.
- 3) It is forbidden that NT\_PORTSEL[3:0] and UPS\_PORTSEL[3:0] have the same values.
- 4) For example, in 808 mode, by default, Port 0 is mapped to Lane 0 and Port 4 is mapped to Lane 1.  
When UPS\_PORTSEL[3:0] is set to 4, Port 0 will be changed to map to Lane 1 and Port 4 be changed to map to Lane 0.
- 5) For example, in 808 mode, by default, Port 1 is NT port and mapped to Lane 4 if NT mode is enabled, and Port 8 is mapped to Lane 3.  
When UPS\_PORTSEL is set to 4 and NT\_PORTSEL is set to 8,  
Port 0 will be changed to map to Lane 1 (Up port)  
Port 4 will be changed to map to Lane 0  
Port 1 will be changed to map to Lane 3 (NT port)  
Port 8 will be changed to map to Lane 4

## 6 FUNCTIONAL DESCRIPTION

Multiple virtual PCI-to-PCI Bridges (VPPB), connected by a virtual PCI bus, reside in the Switch. Each VPPB contains the complete PCIe architecture layers that consist of the physical, data link, and transaction layer. The packets entering the Switch via one of VPPBs are first converted from serial bit-stream into parallel bus signals in physical layer, stripped off the link-related header by data link layer, and then relayed up to the transaction layer to extract out the transaction header. According to the address or ID embedded in the transaction header, the entire transaction packets are forwarded to the destination VPPB for formatting as a serial-type PCIe packet through the transmit circuits in the data link layer and physical layer. The following sections describe these function elements for processing PCIe packets within the Switch.

### 6.1 PHYSICAL LAYER CIRCUIT

The physical layer circuit design is based on the PHY Interface for PCI Express Architecture (PIPE). It contains Physical Media Attachment (PMA) and Physical Coding Sub-layer (PCS) blocks. PMA includes Serializer/Deserializer (SERDES), PLL<sup>1</sup>, Clock Recovery module, receiver detection circuits, beacon transmitter, electrical idle detector, and input/output buffers. PCS consists of framer, 8B/10B encoder/decoder, receiver elastic buffer, and PIPE PHY control/status circuitries. To provide the flexibility for port configuration, each lane has its own control and status signals for MAC to access individually. The main functions of physical layer circuits include the conversion between serial-link and parallel bus, provision of clock source for the Switch, resolving clock difference in receiver end, and detection of physical layer errors.

In order to meet the needs of different application, the drive amplitude, de-emphasis and equalization of each transmitting channels can be adjusted using EEPROM, SMBUS or I2C individually. De-emphasis of -3.5 db is implemented by the transmitters when full swing signaling is used, while an offset can be individually applied to each channel.

#### 6.1.1 RECEIVER DETECTION

The physical layer circuits implement receiver detection, which detects the presence of an attached 50 ohm to ground termination as per PCI Express Specification. The detect circuits determine if the voltage levels of the receiver have crossed the internal threshold after a configurable time determined by the Receiver Detection Threshold field in the PHY Parameter 2 Register (offset 858h, bit[6:4]) as listed in Table 6-1, which can be configured by EEPROM, SMBUS or I2C settings.

**Table 6-1 Receiver Detection Threshold Settings**

Receiver Detection Threshold	Threshold
000	1.0 us
001	2.0 us
010	4.0 us (Recommended)
011	5.0 us
100	7.0 us
101	Reserved
110	Reserved
111	Reserved

<sup>1</sup> Multiple lanes could share the PLL.

## 6.1.2 RECEIVER SIGNAL DETECTION

Receiver signal idling is detected with levels above a programmable threshold specified by Receiver Signal Detect field in the PHY Parameter 2 Register (offset 858h, bit[21:20]) as listed in Table 6-3, and can be configured on a per-port basis via EEPROM, SMBUS or I2C settings.

**Table 6-2 Receiver Signal Detect Threshold**

Receiver Signal Detect	Min (mV ppd)	Max (mV ppd)
00	50	150
01 (Recommended)	65	175
10	75	200
11	120	240

## 6.1.3 RECEIVER EQUALIZATION

The receiver implements programmable equalizer via the Receiver Equalization field in the PHY Parameter 2 Register (offset 858h, bit[25:22] and bit[29:26]) as listed in Table 6-5, which can be configured on a per-port basis via EEPROM, SMBUS or I2C settings.

**Table 6-3 Receiver Equalization Settings**

Receiver Equalization	Equalization
0000 (Recommended)	Off
0010	Low
0110	Medium
1110	High

## 6.1.4 TRANSMITTER SWING

The PCI Express transmitters support implementations of both full voltage swing and half (low) voltage swing. In full swing signaling mode, the transmitters implement de-emphasis, while in half swing mode, the transmitters do not. The Transmitter Swing field in the PHY Parameter 2 Register (offset 858h, bit[30]) is used for the selection of full swing signaling or half swing signaling, which can be configured on a per-port basis via EEPROM, SMBUS or I2C settings.

**Table 6-4 Transmitter Swing Settings**

Transmitter Swing	Mode	De-emphasis
0	Full Voltage Swing	Implemented
1	Half Voltage Swing	Not implemented

## 6.1.5 DRIVE AMPLITUDE AND DE-EMPHASIS SETTINGS

Depending on the operation condition (voltage swing and de-emphasis condition), one of the Drive Amplitude Base Level fields in the PHY Parameter 0 Register (offset 8B0h) and one of the Drive De-Emphasis Base Level fields in the PHY Parameter 1 Register (offset 854h) are active for configuration of the amplitude and de-emphasis.

In addition, optional offset values can be added to the drive amplitude and drive de-emphasis on a per-port basis via EEPROM settings. The final drive amplitude and drive de-emphasis are the summation of the base level value and the offset value. The offset value for drive amplitude is 25 mV pd, and 6.25 mV pd for drive de-emphasis.

The driver output waveform is the synthesis of amplitude and de-emphasis as shown in Figure 6-1. The driver amplitude without de-emphasis is specified as a peak differential voltage level (mVpd), and the driver de-emphasis modifies the driver amplitude.

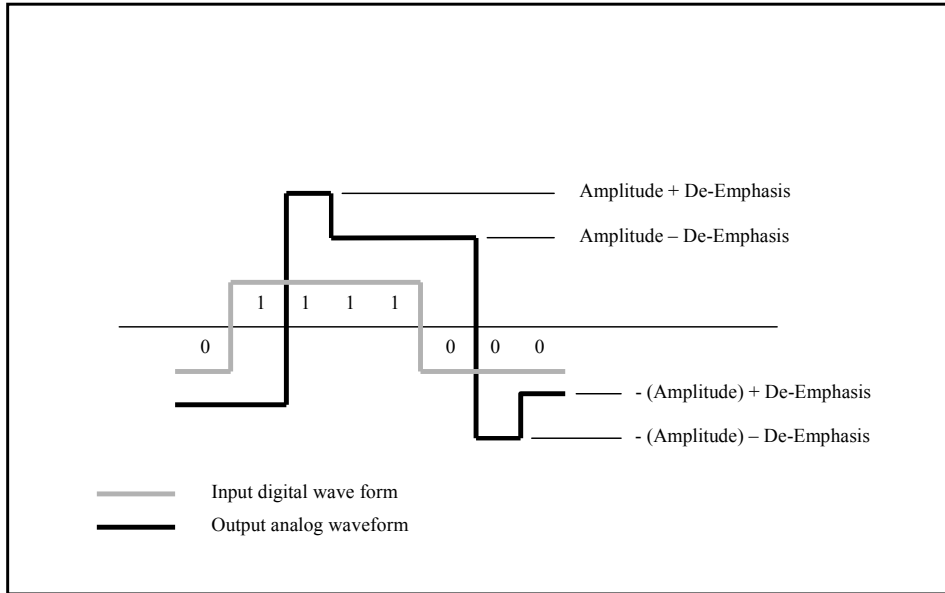

**Figure 6-1 Driver Output Waveform**

### 6.1.6 DRIVE AMPLITUDE

Only one of the Drive Amplitude Level field in the PHY Parameter 0 Register (offset 8B0h, bit[20:16], bit[25:21] and bit[30:26]) listed in Table 6-8 is active depending on the de-emphasis and swing condition. The settings and the corresponding values of the amplitude level are listed in Table 6-9, which can be configured by EEPROM, SMBUS or I2C settings.

**Table 6-5 Drive Amplitude Base Level Registers**

Active Register	De-Emphasis Condition	Swing Condition
Drive Amplitude Level (3P5 Nom)	-3.5 db	Full
Drive Amplitude Level (6P0 Nom)	-6.0 db	Full
Drive Amplitude Level (Half)	N/A	Half

**Table 6-6 Drive Amplitude Base Level Settings**

Setting	Amplitude (mV pd)	Setting	Amplitude (mV pd)	Setting	Amplitude (mV pd)
00000	0	00111	175	01110	350
00001	25	01000	200	01111	375
00010	50	01001	225	10000	400
00011	75	01010	250	10001	425
00100	100	01011	275	10010	450
00101	125	01100	300	10011	475
00110	150	01101	325	Others	Reserved

**Note:**

1. Nominal levels. Actual levels will vary with temperature, voltage and board effects.

2. The maximum nominal amplitude of the output driver is 475 mV pd. Combined values of driver amplitude and de-emphasis greater than 475 mV pd should be avoided.
3. At higher amplitudes, actual swings will be less than the theoretical value due to process variations and environment factors, such as voltage overhead compression, package losses, board losses, and other effects.

### 6.1.7 DRIVE DE-EMPHASIS

The Drive De-Emphasis Level field in the PHY Parameter 1 Register (offset 854h, bit[20:16], bit[25:21] and bit[30:26]) listed in Table 6-12 controls the de-emphasis base level. The settings and the corresponding values of the de-emphasis level are listed in Table 6-13, which can be configured by EEPROM, SMBUS or I2C settings.

**Table 6-7 Drive De-Emphasis Base Level Register**

Register	De-Emphasis Condition
C_EMP_POST_GEN1_3P5_NOM	-3.5 db
C_EMP_POST_GEN2_3P5_NOM	-3.5 db
C_EMP_POST_GEN2_6P0_NOM	-6.0 db

**Table 6-8 Drive De-Emphasis Base Level Settings**

Setting	De-Emphasis (mV pd)	Setting	De-Emphasis (mV pd)	Setting	De-Emphasis (mV pd)
00000	0.0	01011	68.75	10110	137.5
00001	6.25	01100	75.0	10111	143.75
00010	12.5	01101	81.25	11000	150.0
00011	18.75	01110	87.5	11001	156.25
00100	25.0	01111	93.75	11010	162.5
00101	31.25	10000	100.0	11011	168.75
00110	37.5	10001	106.25	11100	175.0
00111	43.75	10010	112.5	11101	181.25
01000	50.0	10011	118.75	11110	187.5
01001	56.25	10100	125.0	11111	194.75
01010	62.5	10101	131.25	-	-

**Note:**

1. Nominal levels. Actual levels will vary with temperature, voltage and board effects.
2. The maximum nominal amplitude of the output driver is 475 mV pd. Combined values of driver amplitude and de-emphasis greater than 475 mV pd should be avoided.
3. At higher amplitudes, actual swings will be less than the theoretical value due to process variations and environment factors, such as voltage overhead compression, package losses, board losses, and other effects.

### 6.1.8 TRANSMITTER ELECTRICAL IDLE LATENCY

After the last character of the PCI Express transmission, the output current is reduced, and a differential voltage of less than 20 mV with common mode of VTX-CM-DC is established within 20 UI. This delay time is programmable via Transmitter PHY Latency field in the PHY Parameter 2 Register (offset 858h, bit[3:0]), which can be configured by EEPROM, SMBUS or I2C settings.

## 6.2 DATA LINK LAYER (DLL)

The Data Link Layer (DLL) provides a reliable data transmission between two PCI Express points. An ACK/NACK protocol is employed to guarantee the integrity of the packets delivered. Each Transaction Layer Packet (TLP) is protected by a 32-bit LCRC for error detection. The DLL receiver performs LCRC calculation to determine if the incoming packet is corrupted in the serial link. If an LCRC error is found, the DLL transmitter would issue a NACK

data link layer packet (DLLP) to the opposite end to request a re-transmission, otherwise an ACK DLLP would be sent out to acknowledge on reception of a good TLP.

In the transmitter, a retry buffer is implemented to store the transmitted TLPs whose corresponding ACK/NACK DLLP have not been received yet. When an ACK is received, the TLPs with sequence number equals to and smaller than that carried in the ACK would be flushed out from the buffer. If a NACK is received or no ACK/NACK is returned from the link partner after the replay timer expires, then a replay mechanism built in DLL transmitter is triggered to re-transmit the corresponding packet that receives NACK or time-out and any other TLP transmitted after that packet.

Meanwhile, the DLL is also responsible for the initialization, updating, and monitoring of the flow-control credit. All of the flow control information is carried by DLLP to the other end of the link. Unlike TLP, DLLP is guarded by 16-bit CRC to detect if data corruption occurs.

In addition, the Media Access Control (MAC) block, which is consisted of LTSSM, multiple lanes de-skew, scrambler/de-scrambler, clock correction from inserting skip order-set, and PIPE-related control/status circuits, is implemented to interface physical layer with data link layer.

### **6.3 TRANSACTION LAYER RECEIVE BLOCK (TLP DECAPSULATION)**

The receiving end of the transaction layer performs header information retrieval and TC/VC mapping (see section 5.5), and it validates the correctness of the transaction type and format. If the TLP is found to contain an illegal header or the indicated packet length mismatches with the actual packet length, then a Malformed TLP is reported as an error associated with the receiving port. To ensure end-to-end data integrity, a 32-bit ECRC is checked against the TLP at the receiver if the digest bit is set in header.

### **6.4 ROUTING**

The transaction layer implements three types of routing protocols: ID-based, address-based, and implicit routing. For configuration reads, configuration writes, transaction completion, and user-defined messages, the packets are routed by their destination ID constituted of bus number, device number, and function number. Address routing is employed to forward I/O or memory transactions to the destination port, which is located within the address range indicated by the address field carried in the packet header. The packet header indicates the packet types including memory read, memory write, IO read, IO write, Message Signaling Interrupt (MSI) and user-defined message. Implicit routing is mainly used to forward system message transactions such as virtual interrupt line, power management, and so on. The message type embedded in the packet header determines the routing mechanism.

If the incoming packet cannot be forwarded to any other port due to a miss to hit the defined address range or targeted ID, this is considered as Unsupported Request (UR) packet, which is similar to a master abort event in PCI protocol.

### **6.5 TC/VC MAPPING**

The 3-bit TC field defined in the header identifies the traffic class of the incoming packets. To enable the differential service, a TC/VC mapping table at destination port that is pre-programmed by system software or EEPROM pre-load is utilized to cast the TC labeled packets into the desired virtual channel. Note that TC0 traffic is mapped into VC0 channel by default. After the TC/VC mapping, the receive block dispatches the incoming request, completion, or data into the appropriate VC0 and VC1 queues.

## 6.6 QUEUE

In PCI Express, it defines six different packet types to represent request, completion, and data. They are respectively Posted Request Header (PH), Posted Request Data payload (PD), Non-Posted Request Header (NPH), Non-Posted Data Payload (NPD), Completion Header (CPLH) and Completion Data payload (CPLD). Each packet with different type would be put into a separate queue in order to facilitate the following ordering processor. Since NPD usually contains one DW, it can be merged with the corresponding NPH into a common queue named NPHD. Except NPHD, each virtual channel (VC0 or VC1) has its own corresponding packet header and data queue. When only VC0 is needed in some applications, VC1 can be disabled and its resources assigned to VC0 by asserting VC1\_EN (Virtual Channel 1 Enable) to low.

### 6.6.1 PH

PH queue provides TLP header spaces for posted memory writes and various message request headers. Each header space occupies sixteen bytes to accommodate 3 DW or 4 DW headers. There are two PH queues for VC0 and VC1 respectively.

### 6.6.2 PD

PD queue is used for storing posted request data. If the received TLP is of the posted request type and is determined to have payload coming with the header, the payload data would be put into PD queue. There are two PD queues for VC0 and VC1 respectively.

### 6.6.3 NPHD

NPHD queue provides TLP header spaces for non-posted request packets, which include memory read, IO read, IO write, configuration read, and configuration write. Each header space takes twenty bytes to accommodate a 3-DW header, a 4-DW header, a 3-DW header with 1-DW data, and a 4-DW header with 1-DW data. There is only one NPHD queue for VC0, since non-posted request cannot be mapped into VC1.

### 6.6.4 CPLH

CPLH queue provides TLP header space for completion packets. Each header space takes twelve bytes to accommodate a 3-DW header. Please note that there are no 4-DW completion headers. There are two CPLH queues for VC0 and VC1 respectively.

### 6.6.5 CPLD

CPLD queue is used for storing completion data. If the received TLP is of the completion type and is determined to have payload coming with the header, the payload data would be put into CPLD queue. There are two CPLD queues for VC0 and VC1 respectively.



## 6.7 TRANSACTION ORDERING

Within a VPPB, a set of ordering rules is defined to regulate the transactions on the PCI Express Switch including Memory, IO, Configuration and Messages, in order to avoid deadlocks and to support the Producer-Consumer model. The ordering rules defined in table 6-9 apply within a single Traffic Class (TC). There is no ordering requirement among transactions within different TC labels. Since the transactions with the same TC label are not allowed to map into different virtual channels, it implies no ordering relationship between the traffic in VC0 and VC1.

**Table 6-9 Summary of PCI Express Ordering Rules**

Row Pass Column	Posted Request	Read Request	Non-posted Write Request	Read Completion	Non-posted Write Completion
Posted Request	Yes/No <sup>1</sup>	Yes <sup>2</sup>	Yes <sup>2</sup>	Yes <sup>2</sup>	Yes <sup>2</sup>
Read Request	No <sup>2</sup>	Yes	Yes	Yes	Yes
Non-posted Write Request	No <sup>2</sup>	Yes	Yes	Yes	Yes
Read Completion	Yes/No <sup>3</sup>	Yes	Yes	Yes	Yes
Non-Posted Write Completion	Yes <sup>4</sup>	Yes	Yes	Yes	Yes

1. When the Relaxed Ordering Attribute bit is cleared, the Posted Request transactions including memory write and message request must complete on the egress bus of VPPB in the order in which they are received on the ingress bus of VPPB. If the Relaxed Ordering Attribute bit is set, the Posted Request is permitted to pass over other Posted Requests occurring before it.
2. A Read Request transmitting in the same direction as a previously queued Posted Request transaction must push the posted write data ahead of it. The Posted Request transaction must complete on the egress bus before the Read Request can be attempted on the egress bus. The Read transaction can go to the same location as the Posted data. Therefore, if the Read transaction were to pass the Posted transaction, it would return stale data.
3. When the Relaxed Ordering Attribute bit is cleared, a Read completion must “pull” ahead of previously queued posted data transmitting in the same direction. In this case, the read data transmits in the same direction as the posted data, and the requestor of the read transaction is on the same side of the VPPB as the completer of the posted transaction. The posted transaction must deliver to the completer before the read data is returned to the requestor. If the Relaxed Ordering Attribute bit is set, then a read completion is permitted to pass a previously queued Memory Write or Message Request.
4. Non-Posted Write Completions are permitted to pass a previous Memory Write or Message Request transaction. Such transactions are actually transmitting in the opposite directions and hence have no ordering relationship.
5. Posted Request transactions must be given opportunities to pass Non-posted Read and Write Requests as well as Completions. Otherwise, deadlocks may occur when some older bridges, which do not support delayed transactions are mixed with PCIe Switch in the same system. A fairness algorithm is used to arbitrate between the Posted Write queue and the Non-posted transaction queue

## 6.8 PORT ARBITRATION

Among multiple ingress ports, the port arbitration built in the egress port determines which incoming packets to be forwarded to the output port. The arbitration algorithm contains hardware fixed Round Robin, 128-phase Weighted Round-Robin and programmable 128-phase time-based WRR. The port arbitration is held within the same VC channel. It means that each port has two port arbitration circuitries for VC0 and VC1 respectively. At the upstream ports, in addition to the inter-port packets, the intra-port packet such as configurations completion would also join the arbitration loop to get the service from Virtual Channel 0.

## 6.9 VC ARBITRATION

After port arbitration, VC arbitration is executed among different VC channels within the same source. Three arbitration algorithms are provided to choose the appropriate VC: Strict Priority, Round Robin or Weighted Round Robin.

## 6.10 FLOW CONTROL

PCI Express employs Credit-Based Flow Control mechanism to make buffer utilization more efficient. The transaction layer transmitter ensures that it does not transmit a TLP to an opposite receiver unless the receiver has enough buffer space to accept the TLP. The transaction layer receiver has the responsibility to advertise the free buffer space to an opposite transmitter to avoid packet stale. In this Switch, each port has its own separate queues for different traffic types and the credits are sent to data link layer on the fly. The data link layer compares the current available credits with the monitored ones and reports the updated credit to the counterpart. If no new credit is acquired, the credit reported is scheduled for every 30 us to prevent the link from entering retrain. On the other hand, the receiver at each egress port gets the usable credits from the opposite end in a link. The output port broadcasts them to all the other ingress ports to get packet transmission.

## 6.11 TRANSACTION LAYER TRANSMIT BLOCK (TLP ENCAPSULATION)

The transmit portion of transaction layer performs the following functions. They construct the all types of forwarded TLP generated from VC arbiter, respond with the completion packets when the local resource (i.e. configuration register) is accessed, and regenerate the message that terminates at receiver to RC if acting as an upstream port.

## 6.12 Access Control Service

Traditionally, the packet routing between the peer-to-peer downstream ports is determined by either the address or ID field embedded in the packet header. ACS provides a mechanism for customer to selectively control access between PCI Express Endpoints attached to the downstream ports of packet switch. If ACS is enabled in the ingress port, the peer-to-peer packet forwarding will follow the rule sets of ACS rather than the destination ID or address. ACS is implemented as a set of capabilities and control registers in the associated hardware component. It brings the following benefits such as preventing the silent data corruption presented in Requests from being incorrectly routed to a peer Endpoint, validating every Request transaction between two downstream components and enabling direct routing of peer-to-peer Memory Requests whose addresses have been Translated when ATS system is being used.

## 6.13 Non-Transparent Bridging (NT Mode Only)

Non-Transparent Bridging function translates Memory Address of the processor, and allows the process to appear as an end-point. This function allows two separate Hosts to be connected together in a multi-host system, such as a multi-processor server or a control module with a built-in processor. Transactions in Base Address Space between two independent Address Spaces are translated and forwarded to each other.

When NT mode is enabled, one of the ports of the packet switch can be programmed to enter NT mode. While the port is in NT mode, the packet switch allows the isolation of address spaces, and the packet switch acts as an endpoint to the Host. The packet switch in NT mode terminates Type 0 Configuration Register packet. All incoming and outgoing memory-type transaction addresses are translated and forwarded from one domain to another using

Base Address Registers (BARs). And the routing ID of the transaction packet is also translated between two host domains.

Registers that are used to notify the system of interrupts are called Interrupts Request (IRQ) registers. Messaging between processor domains achieved through the use of Scratchpad Registers, which both processors from separate process domains can access.

Only one port of the packet switch can be configured to operate in NT mode. NT mode is enabled and disabled by toggling the NT\_ENABLE\_L strapping pin.

### 6.13.1 Device Type Identification

The packet switch uses the Class Code Register (Offset 08h) in PCI Configuration Space Registers to identify its own Bridge Class type, and uses the PCI Express Capability register's Device/Port Type field (Offset 68h) to indicate the device/port type.

In Transparent Mode, the Class Code register returns the value 060400h to identify the packet switch as a PCI-to-PCI Bridge. The Device/Port Type field of the PCI Express Capability register (Offset 68h, bits [23:30]) returns 5h at upstream port and 6h at downstream port.

In Non-Transparent Mode, the Class Code register returns the value 068000h to identify the packet switch as an Other Bridge. The Device/Port Type field of the PCI Express Capability register returns 0h to indicate that it is a PCI Express end point device.

### 6.13.2 Intelligent Adaptor

The packet switch supports intelligent adaptor model in NT mode for multi-host systems. The model is implemented in PCI Express specification as in the established PCI specification. The NT bridge implements two Type 0 CSR Headers: Link Interface and Virtual Interface. NT Port's Link Interface is connected to the System Host, and the Virtual Interface is connected to the internal virtual PCI bus.

In a multi-host system, the Local Host controls all Transparent Port Type 1 and NT Port Virtual Interface Type 0 functions, and the System Host controls only the NT Port Link Interface Type 0 function. The Address Translation between Link Interface and Virtual Interface routes Packets across the Host Domains.

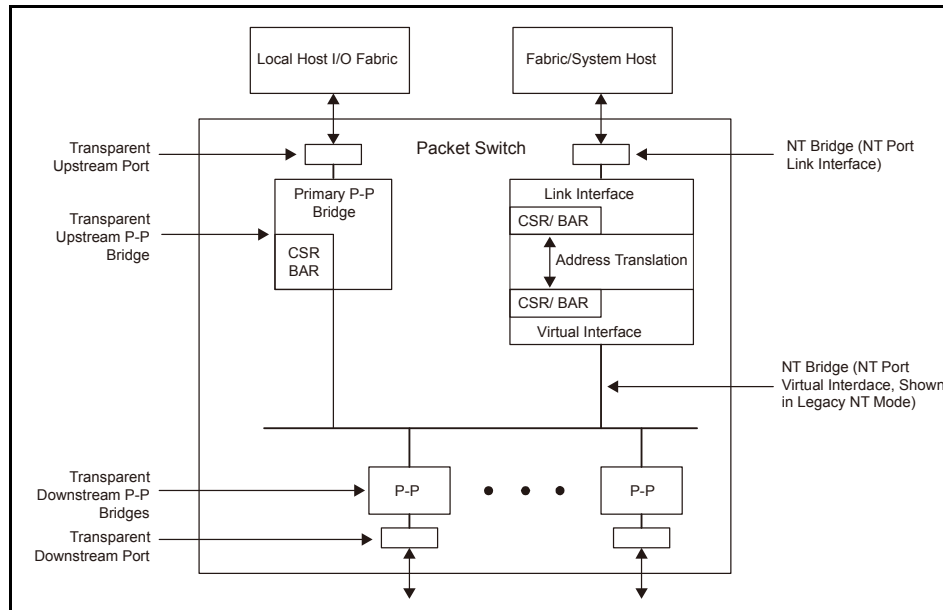

**Figure 6-2 Intelligent Adaptor Architecture**

### 6.13.3 Interrupts Request (IRQ) Registers

The Interrupts Request (IRQ) register sets are used to provide interrupt mechanism across the Non-Transparent port of the packet switch. The registers provide 16-bit interrupts signals in Virtual Interface and Link Interfaces through the following registers.

- Virtual Interface IRQ Set register (Offset C4Ch)
- Virtual Interface IRQ Clear register (Offset C50h)
- Virtual Interface IRQ Mask Set register (Offset C54h)
- Virtual Interface IRQ Mask Clear register (Offset C58h)
- Link Interface IRQ Set register (Offset C5Ch)
- Link Interface IRQ Clear register (Offset C60h)
- Link Interface IRQ Mask Set register (Offset C64h)
- Link Interface IRQ Mask Clear register (Offset C68h)

User software sets one or more bits of the Virtual or Link Interface IRQ Set register to signal that an interrupt is asserted on the Virtual or Link Interface of the Non-Transparent port. When bits of the IRQ Set register are set, the corresponding Mask Set register bits are cleared at the same time. User software sets one or more bits of the Virtual or Link Interface IRQ Clear register to signal that an interrupt is de-asserted on the Virtual or Link Interface of the Non-Transparent port. When bits of the IRQ Clear register are set, the corresponding Mask Clear register bits are cleared at the same time.

### 6.13.4 Scratchpad Registers

Hosts from both side of the Non-Transparent port of the packet switch are able to exchange messages through the implementation of the Scratchpad registers. These registers are readable and writable from both sides, and they

provide a mechanism for inter-host communication of Control and Status information, or can be used as generic RW registers. Eight 32-bit register blocks (offset C6Ch to C8Bh) are allocated for Scratchpad registers.

### 6.13.5 NT Base Address Registers

The Base Address registers (BARs) are implemented to perform address translation in Memory-Map access. One set of BARs is used for Virtual Interface and one set of BARs for Link Interface. The BARs sets up the window size and type and defines the translation address.

BAR0 and BAR1 enable and disable and set up the Memory-Map access to NT-Port Configuration register space. BAR2, BAR3, BAR4, and BAR5 enable and disable and set up the access to other side of the NT-Port.

The BARs is enabled and disabled as indicated in the Memory Space Indicator bits. 32-bit and 64-bit memory window space is supported as indicated in the Memory Map Type bits. The Memory Base Address for memory-mapping is configured in the Base Address bits.

### 6.13.6 Routing ID Translation

The header of transaction layer packet contains Requester ID and/or Completer ID. The Requester/Completer ID is made up by bus number, device number and function number, and is also called the Routing ID. The routing ID represents a unique resource allocated to the device in a host domain. Since each host in different domain assigns routing ID independently, Routing ID translation is necessary for packets that transverse between link and virtual interface. The Virtual Port Registers (Offset D94h-DF3h) are implemented to support the translation of Routing ID between host domains using lookup tables.

## 7 EEPROM INTERFACE AND SYSTEM MANAGEMENT/I2C BUS

The EEPROM interface consists of four pins: EECK (EEPROM clock), EEDI (EEPROM serial data input), EEDO (EEPROM serial data output) and EECS (EEPROM chip select). The Switch supports 2-, or 3-byte address SPI EEPROM parts and automatically determines the appropriate addressing mode. The EEPROM is used to initialize a number of registers before enumeration. This is accomplished after PERST\_L is de-asserted, at which time the data from the EEPROM is loaded. The EEPROM interface is organized into a 16-bit base, and the Switch supplies an 8-bit EEPROM word address.

### 7.1 EEPROM INTERFACE

#### 7.1.1 AUTO MODE EEPROM ACCESS

The Switch may access the EEPROM in a WORD format by utilizing the auto mode through a hardware sequencer. The EEPROM start-control, address, and read/write commands can be accessed through the configuration register. Before each access, the software should check the Autoload Status bit before issuing the next start.

#### 7.1.2 EEPROM MODE AT RESET

During a reset, the Switch will automatically load the information/data from the EEPROM if the automatic load condition is met. The first offset in the EEPROM contains a signature. If the signature is recognized, the autoload initiates right after the reset.

During the autoload, the Bridge will read sequential words from the EEPROM and write to the appropriate registers. Before the Bridge registers can be accessed through the host, the autoload condition should be verified by reading bit [4] offset 87Ch (EEPROM Autoload Status). The host access is allowed only after the status of this bit is set to '1' which indicates that the autoload initialization sequence is complete.

#### 7.1.3 EEPROM SPACE ADDRESS MAP

EEPROM Address	Value	Description
00h	1516h	EEPROM signature
02h	EEPROM_BYTE_SIZE	EEPROM size byte count
04h	CFG_OFFSET_ADDR	1 <sup>st</sup> Configuration Register Address Bit[9:0]: configuration register dword address Bit[15:10]: port number
06h	CFG_LOW_DATA	1 <sup>st</sup> Configuration Register Data (low word)
08h	CFG_HIGH_DATA	1 <sup>st</sup> Configuration Register Data (high word)
0Ah	CFG_OFFSET_ADDR	2 <sup>nd</sup> Configuration Register Address
0Ch	CFG_LOW_DATA	2 <sup>nd</sup> Configuration Register Data (low word)
0Eh	CFG_HIGH_DATA	2 <sup>nd</sup> Configuration Register Data (high word)
...	...	...
FFFh	CFG_HIGH_DATA	Last Configuration Register Data (high word)

## 7.2 SMBUS INTERFACE

The Packet Switch provides the System Management Bus (SMBus), a two-wire interface through which a simple device can communicate with the rest of the system. The SMBus interface on the Packet Switch is a bi-directional slave interface. It can receive data from the SMBus master or send data to the master. The interface allows full access to the configuration registers. A SMBus master, such as the processor or other SMBus devices, can read or write to every RW configuration register (read/write register). In addition, the RO and HwInt registers (read-only and hardware initialized registers) that can be auto-loaded by the EEPROM interface can also be read and written by the SMBus interface. This feature allows increases in the system expandability and flexibility in system implementation.

**Figure 7-1 SMBus Architecture Implementation**

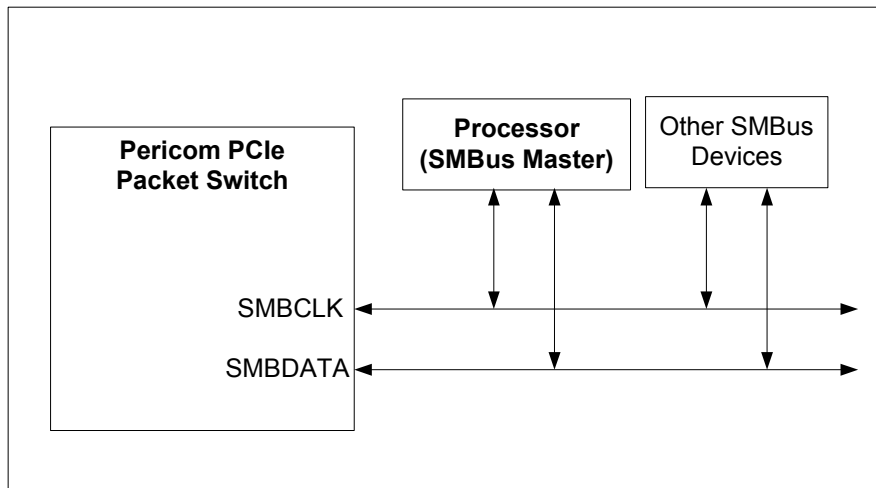

The SMBus interface on the Packet Switch consists of one SMBus clock pin (SCL\_I2C), a SMBus data pin (SDA\_I2C), and 3 SMBus address pins (I2C\_ADDR[2:0]). The SMBus clock pin provides or receives the clock signal. The SMBus data pin facilitates the data transmission and reception. Both of the clock and data pins are bi-directional. The SMBus address pins determine the address to which the Packet Switch responds to. The SMBus address pins generate addresses according to the following table:

**Table 7-1 SMBus Address Pin Configuration**

BIT	SMBus Address
0	I2C_ADDR[0]
1	I2C_ADDR[1]
2	I2C_ADDR[2]
3	1
4	1
5	1
6	0

Software can change the SMBus Slave address, by programming the SMBus/I2C Control Register SMBus/I2C Device Address field.

The PI7C9X2G808PR also supports Packet Error Checking and Packet Error Code (PEC) generation, as explained in the SMBus v2.0.

PI7C9X2G808PR supports three commands:

- Block Write (command BEh) is used to write CFG registers
- Block Write (command BAh), followed by Block Read (command BDh), are used to read CFG registers
- Block Read - Block Write Process Call (commands BAh, CDh) can also be used to read CFG registers

### 7.2.1 SMBUS BLOCK WRITE

The Block Write command is used to write to the PI7C9X2G808PR registers. General SMBus Block Writes are illustrated in Figure 7-2 and Figure 7-3. Table 7-2 explains the elements used in Figure 7-2 and Figure 7-3.

**Figure 7-2 SMBus Block Write Command Format, to Write to a PI7C9X2G808PR Register without PEC**

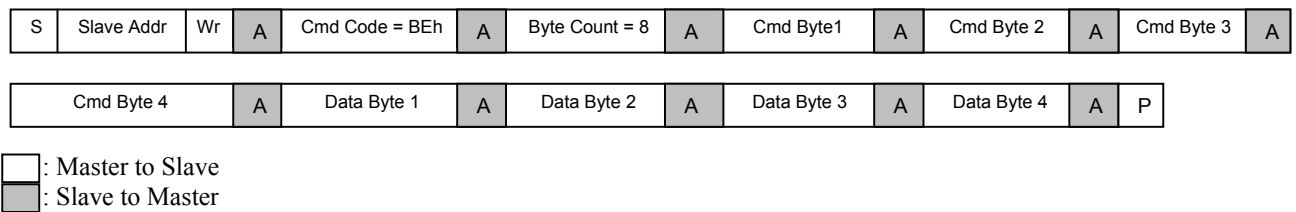

**Figure 7-3 SMBus Block Write Command Format, to Write to a PI7C9X2G808PR Register with PEC**

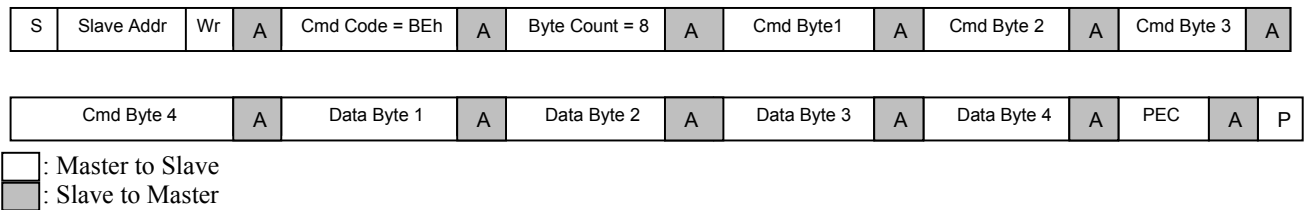

Block Write transactions that are received with incorrect Cmd Code are NACKed, starting from the wrong byte setting, and including subsequent bytes in the packet. For example, if the Byte Count value is not 8, the PI7C9X2G808PR NACKs the byte corresponding to the Byte Count value, as well as any Data bytes following within the same packet.

The byte after Data Byte 4, if present, is taken as the PEC byte, and if present, the PEC is checked. If a packet fails Packet Error Checking, the PI7C9X2G808PR drops the packet (ignores the Write), and returns NACK for the PEC byte, to the SMBus Master. Packet Error Checking can be disabled, by setting the SMBus/I<sup>2</sup>C Control Register PEC Check Disable bit. The Byte Count value, by definition, does not include the PEC byte.

**Table 7-2 Bytes for SMBus Block Write**

Field (Byte) On Bus	Bit(s)	Value/ Description
S	1	<b>START</b> condition
P	1	<b>STOP</b> condition
A	1	<b>Acknowledge</b> (this bit position may be 0 for an ACK or 1 for a NACK)
Command Code	7:0	<b>BEh</b> for Block Write
Byte Count	7:0	<b>08h</b> = 8 bytes to follow (4 Command and 4 Data bytes). The PEC byte is not counted.
Command Byte 1	7:3	<b>Reserved</b>
	2:0	<b>Command</b> 011b = Write register 100b = Read register
	7:4	<b>Reserved</b>
	3:0	<b>Port Select[4:1]</b>



Command Byte 2		2 <sup>nd</sup> Command byte, bits [3:0], and 3 <sup>rd</sup> Command byte, bit 7, combine to form a 5-bit Port Select.
Command Byte 3	7	<b>Port Select[0]</b> 2 <sup>nd</sup> Command byte, bits [3:0], and 3 <sup>rd</sup> Command byte, bit 7, combine to form a 5-bit Port Select. Port Select[4:0] is used to select Port to access. 00h – Port 0 01h – Port 1 or NT Port Link Interface (if NT mode is enabled) 04h ~09h – Port 4 ~ Port 9 10h for NT Port Virtual Interface 02h-03h, 0Ah-0Fh and 11h – 1Fh are reserved
	6	<b>Reserved</b>
	5:2	<b>Byte Enable</b>  <b>Bit Description</b> 2 Byte Enable for Data Byte 4 (PI7C9X2G808PR register bits [7:0]) 3 Byte Enable for Data Byte 3 (PI7C9X2G808PR register bits [15:8]) 4 Byte Enable for Data Byte 2 (PI7C9X2G808PR register bits [23:16]) 5 Byte Enable for Data Byte 1 (PI7C9X2G808PR register bits [31:24])  0 = Corresponding PI7C9X2G808PR register byte will not be modified 1 = Corresponding PI7C9X2G808PR register byte will be modified
	1:0	<b>PI7C9X2G808PR Register Address [11:10]</b>
Command Byte 4	7:0	<b>PI7C9X2G808PR Register Address [9:2]</b> Note: Address bits[1:0] are fixed to 0.
Data Byte 1	7:0	<b>Data write to register bits [31:24]</b>
Data Byte 2	7:0	<b>Data write to register bits [23:16]</b>
Data Byte 3	7:0	<b>Data write to register bits [15:8]</b>
Data Byte 4	7:0	<b>Data write to register bits [7:0]</b>
PEC	7:0	<b>Packet Error Code</b>

Table 7-3 is a sample to write SSID/SSVID register (offset F8h) in Port 1. The register value is 1234\_5678h, with all bytes enabled, and without PEC. The default SMBus Address is 1101000b.

**Table 7-3 Sample SMBus Block Write Byte Sequence**

Byte Number	Byte Type	Value	Description
1	Address	70h	Bits [7:1] for the PI7C9X2G808PR default Slave address of 38h, with bit 0 Cleared to indicate a Write.
2	Command Code	BEh	Command Code for register Write, using a Block Write
3	Byte Count	08h	Byte Count. Four Command Bytes and Four Data Bytes
4	Command Byte 1	03h	For Write command
5	Command Byte 2	00h	Bits [3:0] - Port Select [4:1] (for Port 1)
6	Command Byte 3	BCh	Bit 7 is Port Select[0] Bit 6 is reserved Bits [5:2] are the for Byte Enables; all are active Bits [1:0] are register Address bits [11:10]
7	Command Byte 4	3Eh	PI7C9X2G808PR Register Address bits [9:2] (for offset F8h)
8	Data Byte 1	12h	Data Byte for register bits [31:24]
9	Data Byte 2	34h	Data Byte for register bits [23:16]
10	Data Byte 3	56h	Data Byte for register bits [15:8]
11	Data Byte 4	78h	Data Byte for register bits[7:0]

## 7.2.2 SMBUS BLOCK READ

A Block Read command is used to read PI7C9X2G808PR CFG registers. Similar to CFG register Reads using I<sup>2</sup>C, a SMBus Write sequence must first be performed to select the register to read, followed by a SMBus Read of the corresponding register. There are two ways a PI7C9X2G808PR register can be read:

- Use a Block Write, followed by a Block Read. The Block Write sets up the parameters including Port Number, register address and Byte Enables, and the Block Read performs the actual Read operation.

- Use a Block Read - Block Write Process Call. This command is defined by the SMBus v2.0, and performs a Block Write and Block Read, using a single command. The Block Write portion of the message sets up the register to be read, and then a repeated START followed by the Block Read portion of the message returns the register data specified by the Block Write

The PI7C9X2G808PR always NACKs any incorrect command sequences, starting with the wrong Byte. Upon receiving the Block Read command, the PI7C9X2G808PR returns a PEC to the Master, if after the 4th byte of register data, the Master still requests one more Byte. As a Slave, the PI7C9X2G808PR recognizes the end of the Master's Read cycle, by observing the Master's NACK response for the last Data Byte transmitted by the PI7C9X2G808PR.

Incorrect command sequences are always NACK, starting with the byte that is incorrect. (Refer to Table 7-4.) On the Block Read command, a PEC is returned to the Master, if after the 4th byte of CSR data, the return Master still requests for one additional byte. As a Slave, the PI7C9X2G808PR will know the end of the Master Read cycle, by observing the NACK for the last byte read from the Master.

**Figure 7-4 SMBus Block Write to Set up Read, and Resulting Read that Returns CFG Register Value**

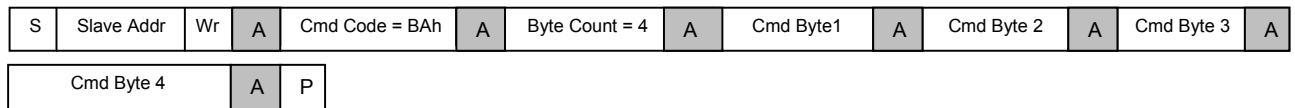

**A Block Write to set up Read**

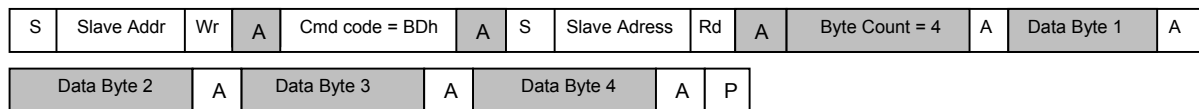

**A Block Read which returns CFG Register Value**

□ : Master to Slave  
 ■ : Slave to Master

**Table 7-4 Bytes for SMBus Block Read**

Field (Byte) On Bus	Bit(s)	Value/ Description
S	1	<b>START</b> condition
P	1	<b>STOP</b> condition
A	1	<b>Acknowledge</b> (this bit position may be 0 for an ACK or 1 for a NACK)
Command Code	7:0	<b>BAh</b> , to set up Read, using Block Writes
Byte Count	7:0	<b>04h</b> , 4 Command bytes
Command Byte 1	7:3	<b>Reserved</b>
	2:0	<b>Command</b> 011b = Write register 100b = Read register
Command Byte 2	7:4	<b>Reserved</b>
	3:0	<b>Port Select[4:1]</b> 2 <sup>nd</sup> Command byte, bits [3:0], and 3 <sup>rd</sup> Command byte, bit 7, combine to form a 5-bit Port Select.
	7	<b>Port Select[0]</b> 2 <sup>nd</sup> Command byte, bits [3:0], and 3 <sup>rd</sup> Command byte, bit 7, combine to form a 5-bit Port Select. Port Select[4:0] is used to select Port to access. 00h – Port 0 01h – Port 1 or NT Port Link Interface (if NT mode is enabled) 04h ~09h – Port 4 ~ Port 9 10h for NT Port Virtual Interface 02h-03h, 0Ah-0Fh and 11h – 1Fh are reserved
	6	<b>Reserved</b>

Command Byte 3	5:2	<b>Byte Enable</b>  <b>Bit Description</b> 2 Byte Enable for Data Byte 4 (PI7C9X2G808PR register bits [7:0]) 3 Byte Enable for Data Byte 3 (PI7C9X2G808PR register bits [15:8]) 4 Byte Enable for Data Byte 2 (PI7C9X2G808PR register bits [23:16]) 5 Byte Enable for Data Byte 1 (PI7C9X2G808PR register bits [31:24])  0 = Corresponding PI7C9X2G808PR register byte will not be modified 1 = Corresponding PI7C9X2G808PR register byte will be modified
	1:0	<b>PI7C9X2G808PR Register Address [11:10]</b>
Command Byte 4	7:0	<b>PI7C9X2G808PR Register Address [9:2]</b>  Note: Address bits[1:0] are fixed to 0.
Command Code	7:0	<b>BDh for Block Read</b>
Data Byte 1	7:0	<b>Return value for CFG register bits [31:24]</b>
Data Byte 2	7:0	<b>Return value for CFG register bits [23:16]</b>
Data Byte 3	7:0	<b>Return value for CFG register bits [15:8]</b>
Data Byte 4	7:0	<b>Return value for CFG register bits [7:0]</b>

Table 7-5, Table 7-6, Table 7-7 and Table 7-8 are a sample to Read SSID/SSVID register (offset F8h) in Port 1. The register value is 0000\_0000h, with all bytes enabled, and without PEC. The default SMBus Address is 1101000b.

**Table 7-5 SMBus Block Write Portion**

Byte Number	Byte Type	Value	Description
1	Address	70h	Bits [7:1] for the PI7C9X2G808PR default Slave address of 38h, with bit 0 Cleared to indicate a Write.
2	Command Code	BAh	Command Code for register Write, using a Block Write
3	Byte Count	04h	Byte Count. Four Command Bytes
4	Command Byte 1	04h	For Read command
5	Command Byte 2	00h	Bits [3:0] - Port Select [4:1] (for Port 1)
6	Command Byte 3	BCh	Bit 7 is Port Select[0] Bit 6 is reserved Bits [5:2] are the for Byte Enables; all are active Bits [1:0] are register Address bits [11:10]
7	Command Byte 4	3Eh	PI7C9X2G808PR Register Address bits [9:2] (for offset F8h)

**Table 7-6 SMBus Block Read Portion**

Byte Number	Byte Type	Value	Description
1	Address	70h	Bits [7:1] value for the PI7C9X2G808PR Slave address of 38h, with bit 0 Cleared to indicate to indicate a Write.
2	Block Read Command Code	BDh	Command code for Block Read of PI7C9X2G808PR registers.

**Table 7-7 SMBus Read Command following Repeat START from Master**

Byte Number	Byte Type	Value	Description
1	Address	71h	Bits [7:1] value for the PI7C9X2G808PR Slave address of 38h, with bit 0 Set to indicate a Read.

**Table 7-8 SMBus Return Bytes**

Byte Number	Byte Type	Value	Description
1	Byte Count	04h	Four Bytes in register
2	Data Byte 1	00h	Register data [31:24]
3	Data Byte 2	00h	Register data [23:16]
4	Data Byte 3	00h	Register data [15:8]
5	Data Byte 4	00h	Register data [7:0]

### 7.2.3 CSR READ, USING SMBUS BLOCK READ – BLOCK WRITE PROCESS CALL

A general SMBus Block Read - Block Write Process Call sequence is illustrated in Figure 7-5. Alternatively, a general SMBus Block Read - Block Write Process Call with PEC sequence is illustrated in Figure 7-6.

Using this command, the register to be read can be set up and read back with one SMBus cycle (a transaction with a START and ending in STOP). There is no STOP condition before the repeated START condition. The command format for the Block Write part of this command has the same sequence as in Table 7-5, except that the Command Code changes to CDh, as illustrated below. Other Bytes remain the same as used in the sequence for SMBus Block Write followed by Block Read. Table 7-9 lists the Command format for Block Read.

**Figure 7-5 CSR Read Operation Using SMBus Block Read – Block Write Process Call**

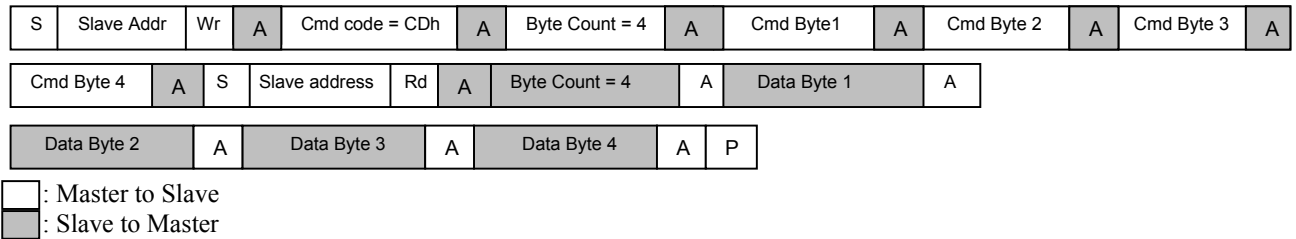

**Figure 7-6 CSR Read Operation Using SMBus Block Read – Block Write Process Call with PEC**

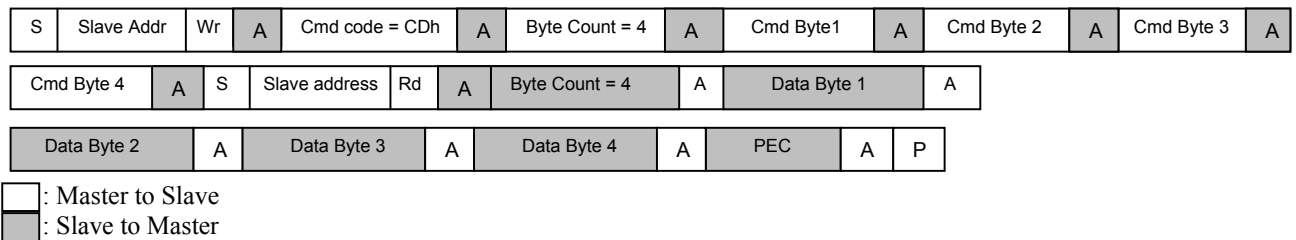

**Table 7-9 Command Format for SMBus Block Read**

Field (Byte) On Bus	Bit(s)	Value/Description
Command Code	7:0	CDh for Block Read (Process Call Read)

### 7.3 I<sup>2</sup>C SLAVE INTERFACE

Inter-Integrated Circuit (I<sup>2</sup>C) is a bus used to connect Integrated Circuits (ICs). Multiple ICs can be connected to an I<sup>2</sup>C Bus, and I<sup>2</sup>C devices that have I<sup>2</sup>C mastering capability can initiate a Data transfer. I<sup>2</sup>C is used for Data transfers between ICs at relatively low rates (100 Kbps), and is used in a variety of applications. For further details regarding I<sup>2</sup>C Buses, refer to the *I<sup>2</sup>C Bus v2.1*.

The PI7C9X2G808PR is an I<sup>2</sup>C Slave. Slave operations allow the PI7C9X2G808PR Configuration registers to be read from or written to by an I<sup>2</sup>C Master, external from the device. I<sup>2</sup>C is a sideband mechanism that allows the device Configuration registers to be programmed, read from, or written to, independent of the PCI Express upstream Link.

**Figure 7-7 Standard Devices to I<sup>2</sup>C Bus Connection Block Diagram**

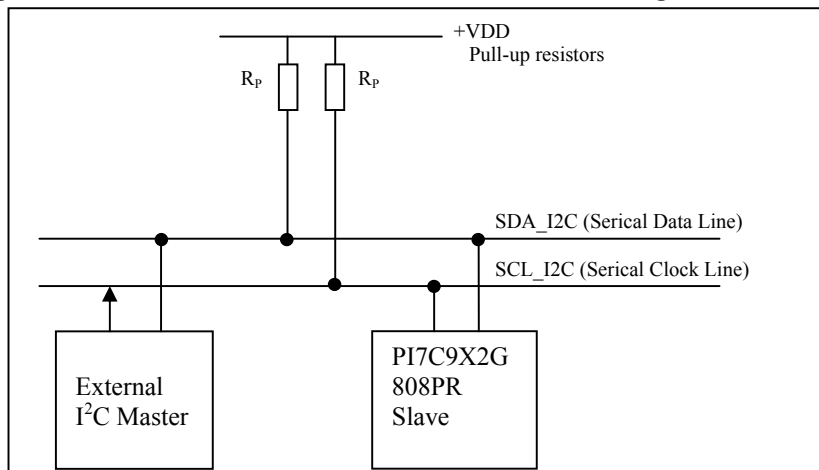

The I<sup>2</sup>C interface on the Packet Switch consists of a I<sup>2</sup>C clock pin (SCL\_I2C), a I<sup>2</sup>C data pin (SDA\_I2C), and 3 I<sup>2</sup>C address pins (I2C\_ADDR[2:0]). The I<sup>2</sup>C clock pin provides or receives the clock signal. The I<sup>2</sup>C data pin facilitates the data transmission and reception. Both of the clock and data pins are bi-directional. The I<sup>2</sup>C address pins determine the address to which the Packet Switch responds to. The I<sup>2</sup>C address pins generate addresses according to the following table:

**Table 7-10 I<sup>2</sup>C Address Pin Configuration**

BIT	I2C Address
0	I2C_ADDR[0]
1	I2C_ADDR[1]
2	I2C_ADDR[2]
3	1
4	1
5	1
6	0

Software can change the I<sup>2</sup>C Slave address, by programming the SMBus/I<sup>2</sup>C Control Register SMBus/I<sup>2</sup>C Device Address field.

### 7.3.1 I<sup>2</sup>C REGISTER WRITE ACCESS

The PI7C9X2G808PR Configuration registers can be read from and written to, based upon I<sup>2</sup>C register Read and Write operations, respectively. An I<sup>2</sup>C Write packet consists of Address Phase bytes and Command Phase bytes, followed by one to four additional I<sup>2</sup>C Data bytes. Table 7-11 defines mapping of the I<sup>2</sup>C Data bytes to the Configuration register Data bytes.

The I<sup>2</sup>C packet starts with the S (START condition) bit. Data bytes are separated by the A (Acknowledge Control Packet (ACK)) or N (Negative Acknowledge (NAK)) bit. The packet ends with the P (STOP condition) bit.

If the Master generates an invalid command, the targeted PI7C9X2G808PR register is not modified.

The PI7C9X2G808PR considers the 1st Data byte of the 4-byte Data phase, following the four Command bytes in the Command phase, as register Byte 3 (bits [31:24]). The next three Data bytes access register Bytes 2 through 0, respectively. Four Data bytes are required, regardless of the Byte Enable Settings in the Command phase. The Master can then generate either a STOP condition (to finish the transfer) or a repeated START condition (to start a new transfer). If the I<sup>2</sup>C Master sends more than the four Data bytes (violating PI7C9X2G808PR protocol), further details regarding J2C protocol, the PI7C9X2G808PR returns a NAK for the extra Data byte(s).

Table 7-12 describes each I<sup>2</sup>C Command byte for Write access. In the packet described in Figure 7-8, Command Bytes 0 through 3 for Writes follow the format specified in Table 7-12.

**Table 7-11 I<sup>2</sup>C Register Write Access**

I2C Data Byte Order	PCI Express Configuration Register Byte
0	Written to register Byte 3
1	Written to register Byte 2
2	Written to register Byte 1
3	Written to register Byte 0

**Table 7-12 I<sup>2</sup>C Command Format for Write Access**

Byte	Bit(s)	Description									
1 <sup>st</sup> (0)	7:3	<b>Reserved</b>									
	2:0	<b>Command</b> 011b = Write register									
2 <sup>nd</sup> (1)	7:4	<b>Reserved</b>									
	3:0	<b>Port Select[4:1]</b> 2 <sup>nd</sup> Command byte, bits [3:0], and 3 <sup>rd</sup> Command byte, bit 7, combine to form a 5-bit Port Select.									
3 <sup>rd</sup> (2)	7	<b>Port Select[0]</b> 2 <sup>nd</sup> Command byte, bits [3:0], and 3 <sup>rd</sup> Command byte, bit 7, combine to form a 5-bit Port Select. Port Select[4:0] is used to select Port to access. 00h – Port 0 01h – Port 1 or NT Port Link Interface (if NT mode is enabled) 02h – 0Fh Port 2 ~ Port 15 10h for NT Port Virtual Interface 11h – 1Fh are reserved									
	6	<b>Reserved</b>									
	5:2	<b>Byte Enable</b>  <table border="0" style="width: 100%;"> <tr> <td style="text-align: left;"><b>Bit</b></td> <td style="text-align: left;"><b>Description</b></td> </tr> <tr> <td>2</td> <td>Byte Enable for Data Byte 4 (PI7C9X2G808PR register bits [7:0])</td> </tr> <tr> <td>3</td> <td>Byte Enable for Data Byte 3 (PI7C9X2G808PR register bits [15:8])</td> </tr> <tr> <td>4</td> <td>Byte Enable for Data Byte 2 (PI7C9X2G808PR register bits [23:16])</td> </tr> <tr> <td>5</td> <td>Byte Enable for Data Byte 1 (PI7C9X2G808PR register bits [31:24])</td> </tr> </table> 0 = Corresponding PI7C9X2G808PR register byte will not be modified 1 = Corresponding PI7C9X2G808PR register byte will be modified	<b>Bit</b>	<b>Description</b>	2	Byte Enable for Data Byte 4 (PI7C9X2G808PR register bits [7:0])	3	Byte Enable for Data Byte 3 (PI7C9X2G808PR register bits [15:8])	4	Byte Enable for Data Byte 2 (PI7C9X2G808PR register bits [23:16])	5
<b>Bit</b>	<b>Description</b>										
2	Byte Enable for Data Byte 4 (PI7C9X2G808PR register bits [7:0])										
3	Byte Enable for Data Byte 3 (PI7C9X2G808PR register bits [15:8])										
4	Byte Enable for Data Byte 2 (PI7C9X2G808PR register bits [23:16])										
5	Byte Enable for Data Byte 1 (PI7C9X2G808PR register bits [31:24])										
4 <sup>th</sup> (3)	1:0	<b>PI7C9X2G808PR Register Address [11:10]</b>									
	7:0	<b>PI7C9X2G808PR Register Address [9:2]</b> Note: Address bits[1:0] are fixed to 0.									

Figure 7-8 I<sup>2</sup>C Write Packet

I<sup>2</sup>C Write Packet Address Phase Byte

Address Cycle			
START	7654321	0	ACK/NAK
S	Slave Address [7:1]	Read/Write Bit 0 = Write	A

I<sup>2</sup>C Write Packet Command Phase Byte

Command Cycle							
76543210	ACK/NAK	76543210	ACK/NAK	76543210	ACK/NAK	76543210	ACK/NAK
Command Byte 0	A	Command Byte 1	A	Command Byte 2	A	Command Byte 3	A

I<sup>2</sup>C Write Packet Data Phase Byte

Write Cycle								
76543210	ACK/NAK	76543210	ACK/NAK	76543210	ACK/NAK	76543210	ACK/NAK	STOP
Register Byte 3	A	Register Byte 2	A	Register Byte 1	A	Register Byte 0	A	P

The following tables illustrate a sample I<sup>2</sup>C packet for writing the PI7C9X2G808PR SSID/SSVID register (offset F8h) for Port 0, with data 1234\_5678h.

*Note: The PI7C9X2G808PR has a default I<sup>2</sup>C Slave address [6:0] value of 38h, with the I<sup>2</sup>C ADDR[2:0] input having a value of 000. The byte sequence on the I<sup>2</sup>C Bus, as listed in the following tables, occurs after the START and before the STOP bits, by which the I<sup>2</sup>C Master frames the transfer.*

Figure 7-9 I<sup>2</sup>C Register Write Access Example

I<sup>2</sup>C Register Write Access Example – Address Cycle

Phase	Value	Description
Address	70h	Bits [7:1] for PI7C9X2G808PR I <sup>2</sup> C Slave Address (38h) with last bit (bit 0) for Write = 0

I<sup>2</sup>C Register Write Access Example – Command Cycle

Byte	Value	Description
0	03h	[7:3] Reserved [2:0] Command, 011b = Write register
1	00h for Port 0	[7:4] Reserved [3:0] Port Select[4:1]
2	3Ch for Port 0	[7] Port Select[0] [6] Reserved [5:2] Byte Enable, all active. [1:0] PI7C9X2G808PR Register Address, Bits [11:10]
3	3Eh	[7:0] PI7C9X2G808PR Register Address, Bits [9:2]

I<sup>2</sup>C Register Write Access Example – Data Cycle

Byte	Value	Description
0	12h	Data to Write for Byte 3
1	34h	Data to Write for Byte 2
2	56h	Data to Write for Byte 1
3	78h	Data to Write for Byte 0

**Figure 7-10 I<sup>2</sup>C Write Command Packet Example**

**I<sup>2</sup>C Write Packet Address Phase Bytes**

1 <sup>st</sup> Cycle			
START	7654321	0	ACK/NAK
S	Slave Address 0111_000b	Read/Write Bit 0 = Write	A

**I<sup>2</sup>C Write Packet Command Phase Bytes**

Command Cycle							
76543210	ACK/NAK	76543210	ACK/NAK	76543210	ACK/NAK	76543210	ACK/NAK
Command Byte 0 0000_0011b	A	Command Byte 1 0000_0000b	A	Command Byte 2 0011_1100b	A	Command Byte 3 0011_1110b	A

**I<sup>2</sup>C Write Packet Data Phase Bytes**

Write Cycle								
76543210	ACK/NAK	76543210	ACK/NAK	76543210	ACK/NAK	76543210	ACK/NAK	STOP
Register Byte 3	A	Register Byte 2	A	Register Byte 1	A	Register Byte 0	A	P

### 7.3.2 I<sup>2</sup>C REGISTER READ ACCESS

When the I<sup>2</sup>C Master attempts to read a PI7C9X2G808PR register, two packets are transmitted. The 1<sup>st</sup> packet consists of Address and Command Phase bytes to the Slave. The 2<sup>nd</sup> packet consists of Address and Data Phase bytes.

According to the I<sup>2</sup>C Bus, v2.1, a Read cycle is triggered when the Read/Write bit (bit 0) of the 1<sup>st</sup> cycle is Set. The Command phase reads the requested register content into the internal buffer. When the I<sup>2</sup>C Read access occurs, the internal buffer value is transferred on to the I<sup>2</sup>C Bus, starting from Byte 3 (bits [31: 24]), followed by the subsequent bytes, with Byte 0 (bits [7:0]) being transferred last. If the I<sup>2</sup>C Master requests more than four bytes, the PI7C9X2G808PR re-transmits the same byte sequence, starting from Byte 3 of the internal buffer.

The 1<sup>st</sup> and 2<sup>nd</sup> I<sup>2</sup>C Read packets perform the following functions:

- 1<sup>st</sup> packet - Selects the register to read
- 2<sup>nd</sup> packet - Reads the register (sample 2<sup>nd</sup> packet provided is for a 7-bit PI7C9X2G808PR I<sup>2</sup>C Slave address)

Although two packets are shown for the I<sup>2</sup>C Read, the I<sup>2</sup>C Master can merge the two packets together into a single packet, by not generating the STOP at the end of the first packet (Master does not relinquish the bus) and generating REPEAT START.

Table 7-13 describes each I<sup>2</sup>C Command byte for Read access. In the packet described in Figure 7-11, Command Bytes 0 through 3 for Reads follow the format specified in Table 7-13.

**Table 7-13 I<sup>2</sup>C Command Format for Read Access**

Byte	Bit(s)	Description
1 <sup>st</sup> (0)	7:3	Reserved
	2:0	Command 100b = Read register
2 <sup>nd</sup> (1)	7:4	Reserved
	3:0	Port Select, Bits [4:1] 2 <sup>nd</sup> Command byte, bit [3:0], and 3 <sup>rd</sup> Command byte, bit 7, combine to form a 5-bit Port Select.
3 <sup>rd</sup> (2)	7	Port Select[0] 2 <sup>nd</sup> Command byte, bits [3:0], and 3 <sup>rd</sup> Command byte, bit 7, combine to form a 5-bit Port Select.



Byte	Bit(s)	Description										
		Port Select[4:0] is used to select Port to access. 00h – Port 0 01h – Port 1 or NT Port Link Interface (if NT mode is enabled) 02h – 0Fh Port 2 ~ Port 15 10h for NT Port Virtual Interface 11h – 1Fh are reserved										
	6	<b>Reserved</b>										
	5:2	<b>Byte Enable</b>  <table border="0"> <tr> <td><b>Bit</b></td> <td><b>Description</b></td> </tr> <tr> <td>2</td> <td>Byte Enable for Data Byte 4 (PI7C9X2G808PR register bits [7:0])</td> </tr> <tr> <td>3</td> <td>Byte Enable for Data Byte 3 (PI7C9X2G808PR register bits [15:8])</td> </tr> <tr> <td>4</td> <td>Byte Enable for Data Byte 2 (PI7C9X2G808PR register bits [23:16])</td> </tr> <tr> <td>5</td> <td>Byte Enable for Data Byte 1 (PI7C9X2G808PR register bits [31:24])</td> </tr> </table> 0 = Corresponding PI7C9X2G808PR register byte will not be modified 1 = Corresponding PI7C9X2G808PR register byte will be modified	<b>Bit</b>	<b>Description</b>	2	Byte Enable for Data Byte 4 (PI7C9X2G808PR register bits [7:0])	3	Byte Enable for Data Byte 3 (PI7C9X2G808PR register bits [15:8])	4	Byte Enable for Data Byte 2 (PI7C9X2G808PR register bits [23:16])	5	Byte Enable for Data Byte 1 (PI7C9X2G808PR register bits [31:24])
<b>Bit</b>	<b>Description</b>											
2	Byte Enable for Data Byte 4 (PI7C9X2G808PR register bits [7:0])											
3	Byte Enable for Data Byte 3 (PI7C9X2G808PR register bits [15:8])											
4	Byte Enable for Data Byte 2 (PI7C9X2G808PR register bits [23:16])											
5	Byte Enable for Data Byte 1 (PI7C9X2G808PR register bits [31:24])											
	1:0	<b>PI7C9X2G808PR Register Address [11:10]</b>										
4 <sup>th</sup> (3)	7:0	<b>PI7C9X2G808PR Register Address [9:2]</b> Note: Address bits[1:0] are fixed to 0.										

Figure 7-11 I<sup>2</sup>C Read Command Packet

**I<sup>2</sup>C Read Command Packet Address Phase Byte (1<sup>st</sup> Packet)**

1 <sup>st</sup> Cycle			
<b>START</b>	<b>7654321</b>	<b>0</b>	<b>ACK/NAK</b>
S	Slave Address[7:1]	Read/Write Bit 0 = Write	A

**I<sup>2</sup>C Read Command Packet Command Phase Byte (1st Packet)**

Write Cycle							
<b>76543210</b>	<b>ACK/NAK</b>	<b>76543210</b>	<b>ACK/NAK</b>	<b>76543210</b>	<b>ACK/NAK</b>	<b>76543210</b>	<b>ACK/NAK</b>
Command Byte 0	A	Command Byte 1	A	Command Byte 2	A	Command Byte 3	A

**I<sup>2</sup>C Read Data Packet Address Phase Byte (2<sup>nd</sup> Packet)**

1 <sup>st</sup> Cycle			
<b>START</b>	<b>7654321</b>	<b>0</b>	<b>ACK/NAK</b>
S	Slave Address[7:1]	Read/Write Bit 1 = Read	A

**I<sup>2</sup>C Read Data Packet Data Phase Byte (2<sup>nd</sup> Packet)**

Write Cycle								
<b>76543210</b>	<b>ACK/NAK</b>	<b>76543210</b>	<b>ACK/NAK</b>	<b>76543210</b>	<b>ACK/NAK</b>	<b>76543210</b>	<b>ACK/NAK</b>	<b>STOP</b>
Register Byte 3	A	Register Byte 2	A	Register Byte 1	A	Register Byte 0	A	P

The following tables illustrate a sample I2C packet for reading the PI7C9X2G808PR SSID/SSVID register (offset F8h) for Port 0. The default value for SSID/SSVID register is 0000\_0000h.

**Note:** The PI7C9X2G808PR has a default I<sup>2</sup>C Slave address [6:0] value of 38h, with the I2C\_ADDR[2:0] inputs having a value of 000. The byte sequence on the I<sup>2</sup>C Bus, as listed in the following tables, occurs after the START and before the STOP bits, by which the I<sup>2</sup>C Master frames the transfer.

Figure 7-12 I<sup>2</sup>C Register Read Access Example

I<sup>2</sup>C Register Read Access Example – Address Cycle (1<sup>st</sup> Packet)

Phase	Value	Description
Address	70h	Bits [7:1] for PI7C9X2G808PR I <sup>2</sup> C Slave Address (38h) with last bit (bit 0) for Write = 0

I<sup>2</sup>C Register Read Access Example – Command Cycle (1<sup>st</sup> Packet)

Byte	Value	Description
0	04h	[7:3] Reserved [2:0] Command , 100b = Read register
1	00h for Port 0	[7:4] Reserved [3:0] Port Select[4:1]
2	3Ch for Port 0	[7] Port Select[0] [6] Reserved [5:2] Byte Enable, All active. [1:0] PI7C9X2G808PR Register Address, Bits [11:10]
3	3Eh	[7:0] PI7C9X2G808PR Register Address, Bits [9:2]

I<sup>2</sup>C Register Read Access Example – 2<sup>nd</sup> Packet

Phase	Value	Description
Address	71h	Bits [7:1] for PI7C9X2G808PR I <sup>2</sup> C Slave Address (38h) with last bit (bit 0) for Read = 1
Read	00h	Byte 3 of Register Read
	00h	Byte 2 of Register Read
	00h	Byte 1 of Register Read
	00h	Byte 0 of Register Read

Figure 7-13 I<sup>2</sup>C Read Command Packet

I<sup>2</sup>C Read Command Packet Address Phase Bytes (1<sup>st</sup> Packet)

1 <sup>st</sup> Cycle			
START	7654321	0	ACK/NAK
S	Slave Address 0111_000b	Read/Write Bit 0 = Write	A

I<sup>2</sup>C Read Command Packet Command Phase Bytes (1<sup>st</sup> Packet)

Command Cycle						
76543210	ACK/NAK	76543210	ACK/NAK	76543210	ACK/NAK	76543210
Command Byte 0 0000_0100b	A	Command Byte 1 0000_0000b	A	Command Byte 2 0011_1100b	A	Command Byte 3 0011_1110b

I<sup>2</sup>C Read Data Packet Address Phase Bytes (2<sup>nd</sup> Packet)

1 <sup>st</sup> Cycle			
START	7654321	0	ACK/NAK
S	Slave Address [7:1] 0111_000b	Read/Write Bit 1 = Read	A

I<sup>2</sup>C Read Data Packet Data Phase Bytes (2<sup>nd</sup> Packet)

Command Cycle							
76543210	ACK/NAK	76543210	ACK/NAK	76543210	ACK/NAK	76543210	Stop
Register Byte3 0000_0000b	A	Register Byte2 0000_0000b	A	Register Byte1 0000_0000b	A	Register Byte0 0000_0000b	P

## 8 REGISTER DESCRIPTION

### 8.1 REGISTER TYPES

This chapter details the Packet Switch registers, including

- Bit names
- Description of register functions
- Type, refer to Table 8-1
- Whether the default value can be modified by EEPROM and/or I2C/SMBUS
- Default value

**Table 8-1 Register Types**

REGISTER TYPE	DEFINITION
HwInt	Hardware Initialization
RO	Read Only
RW	Read / Write
RWIC	Read / Write 1 to Clear
RsvdP	Reserved

### 8.2 TRANSPARENT MODE CONFIGURATION REGISTERS

When the port of the Switch is set to operate at the transparent mode, it is represented by a logical PCI-to-PCI Bridge that implements type 1 configuration space header. The following table details the allocation of the register fields of the PCI 2.3 compatible type 1 configuration space header.

31 – 24	23 – 16	15 – 8	7 – 0	BYTE OFFSET
Device ID		Vendor ID		00h
Primary Status		Command		04h
Class Code		Revision ID		08h
Reserved	Header Type	Primary Latency Timer	Cache Line Size	0Ch
Base Address 0 for Upstream Port) / Reserved for Downstream Ports				10h
Base Address 1 for Upstream Port) / Reserved for Downstream Ports				14h
Secondary Latency Timer	Subordinate Bus Number	Secondary Bus Number	Primary Bus Number	18h
Secondary Status		I/O Limit Address	I/O Base Address	1Ch
Memory Limit Address		Memory Base Address		20h
Prefetchable Memory Limit Address		Prefetchable Memory Base Address		24h
Prefetchable Memory Base Address Upper 32-bit				28h
Prefetchable Memory Limit Address Upper 32-bit				2Ch
I/O Limit Address Upper 16-bit		I/O Base Address Upper 16-bit		30h
Reserved			Capability Pointer to 40h	34h
Reserved				38h
Bridge Control		Interrupt Pin	Interrupt Line	3Ch
Power Management Capabilities		Next Item Pointer=48h	Capability ID=01h	40h
PM Data	PPB Support Extensions	Power Management Data		44h
Message Control		Next Item Pointer=68h	Capability ID=05h	48h
Message Address				4Ch
Message Upper Address				50h
Reserved		Message Data		54h
Reserved				58h – 64h
PCI Express Capabilities Register		Next Item Pointer=A4h	Capability ID=10h	68h
Device Capabilities				6Ch
Device Status		Device Control		70h
Link Capabilities				74h
Link Status		Link Control		78h

31 – 24	23 – 16	15 – 8	7 – 0	BYTE OFFSET
Slot Capabilities				7Ch
Slot Status		Slot Control		80h
Reserved				84h – 88h
Device Capabilities 2				8Ch
Device Status 2		Device Control 2		90h
Link Capabilities 2				94h
Link Status 2		Link Control 2		98h
Slot Capabilities 2				9Ch
Slot Status 2		Slot Control 2		A0h
Reserved		Next Item Pointer=00h	SSID/SSVID Capability ID=0Dh	A4h
SSID		SSVID		A8h
Reserved				ACh – E0h
BAR 0-1 Configuration				E4h
Reserved				E8h - FCh

Other than the PCI 2.3 compatible configuration space header, the Switch also implements PCI express extended configuration space header, which includes advanced error reporting, virtual channel, and power budgeting capability registers. The following table details the allocation of the register fields of PCI express extended capability space header. The first extended capability always begins at offset 100h with a PCI Express Enhanced Capability header and the rest of capabilities are located at an offset greater than 0FFh relative to the beginning of PCI compatible configuration space.

31 – 24	23 – 16	15 – 8	7 – 0	BYTE OFFSET
Next Capability Offset=FB4h		Cap. Version	PCI Express Extended Capability ID=0003h	100h
Serial Number Lower DW				104h
Serial Number Upper DW				108h
Reserved				10Ch – 134h
Next Capability Offset=148h		Cap. Version	PCI Express Extended Capability ID=0004h	138h
Reserved		Data Select Register		13Ch
Data Register				140h
Reserved		Power Budget Capability Register		144h
Next Capability Offset=270h (Up) 520h (Down)		Cap. Version	PCI Express Extended Capability ID=0002h	148h
Port VC Capability Register 1				14Ch
VC Arbitration Table Offset=4h	Port VC Capability Register 2			150h
Port VC Status		Port VC Control		154h
Port Arbitration Table Offset=5h	VC Resource Capability Register (0)			158h
VC Resource Control Register (0)				15Ch
VC Resource Status Register (0)		Reserved		160h
Port Arbitration Table Offset=6h	VC Resource Capability Register (1)			164h
VC Resource Control Register (1)				168h
VC Resource Status Register (1)		Reserved		16Ch
Reserved				170h – 184h
VC Arbitration Table 0				188h
VC Arbitration Table 1				18Ch
VC Arbitration Table 2				190h
VC Arbitration Table 3				194h
Port VC0 Arbitration Table 0 (Low)				198h
Port VC0 Arbitration Table 0 (Upper)				19Ch
Port VC0 Arbitration Table 1 (Low)				1A0h
Port VC0 Arbitration Table 1 (Upper)				1A4h
Port VC1 Arbitration Table 0 (Low)				1A8h
Port VC1 Arbitration Table 0 (Upper)				1ACh
Port VC1 Arbitration Table 1 (Low)				1B0h
Port VC1 Arbitration Table 1 (Upper)				1B4h

31 – 24	23 – 16	15 - 8	7 – 0	BYTE OFFSET
Reserved				1B8h – 1C4h
ECC Error Check Disable				1C8h
Reserved				1CCh – 1D8h
NT-UP Port Selection				1DCh
Power Manager Hot Plug Configuration				1E0h
Reserved				1E4h – 1F0h
Software Lane Status				1F4h
Reserved				1F8h – 204h
De-emphasis Control		Rate Control		208h
Reserved		Compliance Mode		20Ch
Reserved				210h – 21Ch
Even Port Physical Layer Command and Status				220h
Odd Port Physical Layer Command and Status				224h
Reserved				228h – 22Ch
Even Port Disable / Quiet / Test Pattern Rate				230h
Odd Port Disable / Quiet / Test Pattern Rate				234h
Reserved				238h – 26Ch
Next Capability Offset=900h	Cap version	PCI Express Extended Capability ID=001Eh		270h
L1 PM Substates Capability				274h
L1 PM Substates Control 1				278h
L1 PM Substates Control 2				27Ch
Reserved				280h – 340h
SMBUS Control and Status				344h
Reserved				348h
Disable Downstream Port Hot Reset				34Ch
Reserved				350h – 51Ch
Next Capability Offset=270h	Cap version	PCI Express Extended Capability ID=000Dh		520h
ACS Control		ACS Capability		524h
Reserved		Egress Control Vector		528h
Reserved				52Ch – 628h
GPIO 0-15 Direction Control				62Ch
GPIO 16-31 Direction Control				630h
Reserved				634h
GPIO Input De-bounce				638h
GPIO 0-15 Input Data				63Ch
GPIO 16-31 Input Data				640h
GPIO 0-15 Output Data				644h
GPIO 16-31 Output Data				648h
GPIO 0-31 Interrupt Polarity				64Ch
GPIO 0-31 Interrupt Status				650h
GPIO 0-31 Interrupt Mask				654h
Reserved				658h-840h
XPIP_CSR 0				844h
XPIP_CSR 1				848h
Decode VGA	Reserved			84Ch
Switch Operation Mode				850h
PHY Parameter 1	PHY Parameter 2		XPIP_CSR 2	854h
PHY Parameter 3				858h
PHY Parameter 4				85Ch
XPIP_CSR 3				860h
XPIP_CSR 4				864h
XPIP_CSR 5				868h
Non Transfer Mode				86Ch
Operation Mode				870h
Device Specific PM Event				874h
EEPROM Control				878h
EEPROM Address and Data				87Ch
Debugout Control				880h
Debugout Data				884h
LTSSM CSR				888h
MAC CSR 1				88Ch
MAC CSR 1				890h

31 – 24	23 – 16	15 - 8	7 – 0	BYTE OFFSET
Reserved				894h – 8A0h
Power Saving Disable				8A4h
Transaction Layer CSR				8A8h
ACK Latency Timer		Replay Time-out Counter		8ACh
PHY Parameter 0		Port Misc 0		8B0h
XPIP CSR 7	XPIP CSR 6		Port Misc 1	8B4h
Reserved		Port Misc 2		8B8h
LED Display CSR				8BCh
Reserved				8C0h – 8FCh
Next Capability Offset=000h		Cap. Version	PCI Express Extended Capability ID=0012h	900h
Multi-Case Control		Multi-Case Capability		904h
Multi-Case Base Address 0				908h
Multi-Case Base Address 1				90Ch
Multi-Case Receive				910h
Reserved				914h
Multi-Case Block All				918h
Reserved				91Ch
Multi-Case Block Untranslated				920h
Reserved				924h – FACH
EEPROM Scratchpad				FB0h
Next Capability Offset= 138h (Up) 148h (Down)		Cap. Version	PCI Express Extended Capability ID=0001h	FB4h
Uncorrectable Error Status Register				FB8h
Uncorrectable Error Mask Register				FBCCh
Uncorrectable Error Severity Register				FC0h
Correctable Error Status Register				FC4h
Correctable Error Mask Register				FC8h
Advanced Error Capabilities and Control Register				FCCCh
Header Log Register 0				FD0h
Header Log Register 1				FD4h
Header Log Register 2				FD8h
Header Log Register 3				FDCh
Reserved				FE0h – FFCh

### 8.2.1 VENDOR ID REGISTER – OFFSET 00h

BIT	FUNCTION	TYPE	DESCRIPTION	EEPROM/ I2C-SMBUS	DEFAULT
15:0	Vendor ID	RO	Identifies Peircom as the vendor of this device.	Yes	12D8h

### 8.2.2 DEVICE ID REGISTER – OFFSET 00h

BIT	FUNCTION	TYPE	DESCRIPTION	EEPROM/ I2C-SMBUS	DEFAULT
31:16	Device ID	RO	Identifies this device as the PI7C9X2G808PR.	Yes	8608h

### 8.2.3 COMMAND REGISTER – OFFSET 04h

BIT	FUNCTION	TYPE	DESCRIPTION	EEPROM/ I2C-SMBUS	DEFAULT
0	I/O Space Enable	RW	0b: Ignores I/O transactions on the primary interface 1b: Enables responses to I/O transactions on the primary interface	No/Yes	0
1	Memory Space Enable	RW	0b: Ignores memory transactions on the primary interface 1b: Enables responses to memory transactions on the primary interface	No/Yes	0

BIT	FUNCTION	TYPE	DESCRIPTION	EEPROM/ I2C-SMBUS	DEFAULT
2	Bus Master Enable	RW	0b: Does not initiate memory or I/O transactions on the upstream port and handles as an Unsupported Request (UR) to memory and I/O transactions on the downstream port. For Non-Posted Requests, a completion with UR completion status must be returned 1b: Enables the Switch Port to forward memory and I/O Read/Write transactions in the upstream direction	No/Yes	0
3	Special Cycle Enable	RsvdP	Not Support.	No	0
4	Memory Write And Invalidate Enable	RsvdP	Not support.	No	0
5	VGA Palette Snoop Enable	RsvdP	Not Support.	No	0
6	Parity Error Response Enable	RW	0b: Switch may ignore any parity errors that it detects and continue normal operation 1b: Switch must take its normal action when a parity error is detected	No/Yes	0
7	Wait Cycle Control	RsvdP	Not Support.	No	0
8	SERR# enable	RW	0b: Disables the reporting of Non-fatal and Fatal errors detected by the Switch to the Root Complex 1b: Enables the Non-fatal and Fatal error reporting to Root Complex	No/Yes	0
9	Fast Back-to-Back Enable	RsvdP	Not Support.	No	0
10	Interrupt Disable	RW	Controls the ability of a PCI Express device to generate INTx Interrupt Messages. In the Switch, this bit does not affect the forwarding of INTx messages from the downstream ports.	No/Yes	0
15:11	Reserved	RsvdP	Not Support.	No	0000 0b

## 8.2.4 PRIMARY STATUS REGISTER – OFFSET 04h

BIT	FUNCTION	TYPE	DESCRIPTION	EEPROM/ I2C-SMBUS	DEFAULT
18:16	Reserved	RsvdP	Not Support.	No	000b
19	Interrupt Status	RO	Indicates that an INTx Interrupt Message is pending internally to the device. In the Switch, the forwarding of INTx messages from the downstream device of the Switch port is not reflected in this bit. Must be hardwired to 0.	No	0
20	Capabilities List	RO	Set to 1b to enable support for the capability list (offset 34h is the pointer to the data structure).	No	1
21	66MHz Capable	RO	Does not apply to PCI Express. Must be hardwired to 0.	No	0
22	Reserved	RsvdP	Not Support.	No	0
23	Fast Back-to-Back Capable	RsvdP	Not Support.	No	0
24	Master Data Parity Error	RW1C	Set to 1b (by a requester) whenever a Parity error is detected or forwarded on the primary side of the port in a Switch.  If the Parity Error Response Enable bit is cleared, this bit is never set.	No/Yes	0
26:25	DEVSEL# timing	RsvdP	Not Support.	No	00b
27	Signaled Target Abort	RsvdP	Not Support.	No	0
28	Received Target Abort	RsvdP	Not Support.	No	0
29	Received Master Abort	RsvdP	Not Support.	No	0
30	Signaled System Error	RW1C	Set to 1b when the Switch sends an ERR_FATAL or ERR_NONFATAL Message, and the SERR Enable bit in the Command register is 1.	No/Yes	0
31	Detected Parity Error	RW1C	Set to 1b whenever the primary side of the port in a Switch receives a Poisoned TLP.	No/Yes	0

### 8.2.5 REVISION ID REGISTER – OFFSET 08h

BIT	FUNCTION	TYPE	DESCRIPTION	EEPROM/ I2C-SMBUS	DEFAULT
7:0	Revision	RO	Indicates revision number of device.	Yes	00h

### 8.2.6 CLASS REGISTER – OFFSET 08h

BIT	FUNCTION	TYPE	DESCRIPTION	EEPROM/ I2C-SMBUS	DEFAULT
15:8	Programming Interface	RO	Read as 00h to indicate no programming interfaces have been defined for PCI-to-PCI Bridges.	No	00h
23:16	Sub-Class Code	RO	Read as 04h to indicate device is a PCI-to-PCI Bridge.	No	04h
31:24	Base Class Code	RO	Read as 06h to indicate device is a Bridge device.	No	06h

### 8.2.7 CACHE LINE REGISTER – OFFSET 0Ch

BIT	FUNCTION	TYPE	DESCRIPTION	EEPROM/ I2C-SMBUS	DEFAULT
7:0	Cache Line Size	RW	The cache line size register is set by the system firmware and the operating system cache line size. This field is implemented by PCI Express devices as a RW field for legacy compatibility, but it has no impact on any PCI Express device functionality.	No/Yes	00h

### 8.2.8 PRIMARY LATENCY TIMER REGISTER – OFFSET 0Ch

BIT	FUNCTION	TYPE	DESCRIPTION	EEPROM/ I2C-SMBUS	DEFAULT
15:8	Primary Latency Timer	RsvdP	Not Support.	No	00h

### 8.2.9 HEADER TYPE REGISTER – OFFSET 0Ch

BIT	FUNCTION	TYPE	DESCRIPTION	EEPROM/ I2C-SMBUS	DEFAULT
22:16	Header Type	RO	Read as 01h to indicate that the register layout conforms to the standard PCI-to-PCI Bridge layout.	No	01h
23	Multi-Function Device	RO	0b: Single function device 1b: Multiple functions device	No	1 for Up 0 for Down

### 8.2.10 BASE ADDRESS 0 REGISTER – OFFSET 10h (Upstream Port Only)

BIT	FUNCTION	TYPE	DESCRIPTION	EEPROM/ I2C-SMBUS	DEFAULT
0	Memory Space Indicator	RO	0b: indicate Memory Base address 1b: indicate I/O Base address	No	0
2:1	64-bit Addressing	RO	00b: 32-bit addressing 10b: 64-bit addressing Others: Reserved	No	00b
3	Prefetchable	RO	0b: Non-prefetchable 1b: Prefetchable	No	0
16:4	Reserved	RsvdP	Not Support.	No	0-0h
31:17	Base Address 0	RW	Use this Memory base address to map the packet switch registers.	No/Yes	0-0h



### 8.2.11 BASE ADDRESS 1 REGISTER – OFFSET 14h (Upstream Port Only)

BIT	FUNCTION	TYPE	DESCRIPTION	EEPROM/ I2C-SMBUS	DEFAULT
31:0	Base Address 1	RO/RW	RO when the Base Address 0 register is not 64-bit addressing (offset 10h[2:1] is not 10b). RW when the Base Address 0 register is 64-bit addressing. Base Address 1 is used to provide the upper 32 Address bits when offset 10h[2:1] is set to 10b.	No/Yes	0000_0000h

### 8.2.12 PRIMARY BUS NUMBER REGISTER – OFFSET 18h

BIT	FUNCTION	TYPE	DESCRIPTION	EEPROM/ I2C-SMBUS	DEFAULT
7:0	Primary Bus Number	RW	Indicates the number of the PCI bus to which the primary interface is connected. The value is set in software during configuration.	No/Yes	00h

### 8.2.13 SECONDARY BUS NUMBER REGISTER – OFFSET 18h

BIT	FUNCTION	TYPE	DESCRIPTION	EEPROM/ I2C-SMBUS	DEFAULT
15:8	Secondary Bus Number	RW	Indicates the number of the PCI bus to which the secondary interface is connected. The value is set in software during configuration.	No/Yes	00h

### 8.2.14 SUBORDINATE BUS NUMBER REGISTER – OFFSET 18h

BIT	FUNCTION	TYPE	DESCRIPTION	EEPROM/ I2C-SMBUS	DEFAULT
23:16	Subordinate Bus Number	RW	Indicates the number of the PCI bus with the highest number that is subordinate to the Bridge. The value is set in software during configuration.	No/Yes	00h

### 8.2.15 SECONDARY LATENCY TIMER REGISTER – OFFSET 18h

BIT	FUNCTION	TYPE	DESCRIPTION	EEPROM/ I2C-SMBUS	DEFAULT
31:24	Secondary Latency Timer	RsvdP	Not Support.	No	00h

### 8.2.16 I/O BASE ADDRESS REGISTER – OFFSET 1Ch

BIT	FUNCTION	TYPE	DESCRIPTION	EEPROM/ I2C-SMBUS	DEFAULT
3:0	32-bit Indicator	RO	Read as 1h to indicate 32-bit I/O addressing.	No	1h
7:4	I/O Base Address [15:12]	RW	Defines the bottom address of the I/O address range for the Bridge to determine when to forward I/O transactions from one interface to the other. The upper 4 bits correspond to address bits [15:12] and are writable. The lower 12 bits corresponding to address bits [11:0] are assumed to be 0. The upper 16 bits corresponding to address bits [31:16] are defined in the I/O base address upper 16 bits address register.	No/Yes	0h

### 8.2.17 I/O LIMIT ADDRESS REGISTER – OFFSET 1Ch

BIT	FUNCTION	TYPE	DESCRIPTION	EEPROM/ I2C-SMBUS	DEFAULT
11:8	32-bit Indicator	RO	Read as 1h to indicate 32-bit I/O addressing.	No	1h
15:12	I/O Limit Address [15:12]	RW	Defines the top address of the I/O address range for the Bridge to determine when to forward I/O transactions from one interface to the other. The upper 4 bits correspond to address bits [15:12] and are writable. The lower 12 bits corresponding to address bits [11:0] are assumed to be FFFh. The upper 16 bits corresponding to address bits [31:16] are defined in the I/O limit address upper 16 bits address register.	No/Yes	0h

### 8.2.18 SECONDARY STATUS REGISTER – OFFSET 1Ch

BIT	FUNCTION	TYPE	DESCRIPTION	EEPROM/ I2C-SMBUS	DEFAULT
20:16	Reserved	RsvdP	Not Support.	No	0 0000b
21	66MHz Capable	RsvdP	Not Support.	No	0
22	Reserved	RsvdP	Not Support.	No	0
23	Fast Back-to-Back Capable	RsvdP	Not Support.	No	0
24	Master Data Parity Error	RW1C	Set to 1b (by a requester) whenever a Parity error is detected or forwarded on the secondary side of the port in a Switch.  If the Parity Error Response Enable bit is cleared, this bit is never set.	No/Yes	0
26:25	DEVSEL_L timing	RsvdP	Not Support.	No	00b
27	Signaled Target Abort	RsvdP	Not Support.	No	0
28	Received Target Abort	RsvdP	Not Support.	No	0
29	Received Master Abort	RsvdP	Not Support.	No	0
30	Received System Error	RW1C	Set to 1b when the Switch sends an ERR_FATAL or ERR_NONFATAL Message, and the SERR Enable bit in the Bridge Control register is 1.	No/Yes	0
31	Detected Parity Error	RW1C	Set to 1b whenever the secondary side of the port in a Switch receives a Poisoned TLP.	No/Yes	0

### 8.2.19 MEMORY BASE ADDRESS REGISTER – OFFSET 20h

BIT	FUNCTION	TYPE	DESCRIPTION	EEPROM/ I2C-SMBUS	DEFAULT
3:0	Reserved	RsvdP	Not Support.	No	0h
15:4	Memory Base Address [31:20]	RW	Defines the bottom address of an address range for the Bridge to determine when to forward memory transactions from one interface to the other. The upper 12 bits correspond to address bits [31:20] and are able to be written to. The lower 20 bits corresponding to address bits [19:0] are assumed to be 0.	No/Yes	000h

### 8.2.20 MEMORY LIMIT ADDRESS REGISTER – OFFSET 20h

BIT	FUNCTION	TYPE	DESCRIPTION	EEPROM/ I2C-SMBUS	DEFAULT
19:16	Reserved	RsvdP	Not Support.	No	0h
31:20	Memory Limit Address [31:20]	RW	Defines the top address of an address range for the Bridge to determine when to forward memory transactions from one interface	No/Yes	000h

			to the other. The upper 12 bits correspond to address bits [31:20] and are writable. The lower 20 bits corresponding to address bits [19:0] are assumed to be FFFFh.		
--	--	--	--	--	--

### 8.2.21 PREFETCHABLE MEMORY BASE ADDRESS REGISTER – OFFSET 24h

BIT	FUNCTION	TYPE	DESCRIPTION	EEPROM/ I2C-SMBUS	DEFAULT
3:0	64-bit addressing	RO	Read as 1h to indicate 64-bit addressing.	No	1h
15:4	Prefetchable Memory Base Address [31:20]	RW	Defines the bottom address of an address range for the Bridge to determine when to forward memory read and write transactions from one interface to the other. The upper 12 bits correspond to address bits [31:20] and are writable. The lower 20 bits are assumed to be 0. The memory base register upper 32 bits contain the upper half of the base address.	No/Yes	000h

### 8.2.22 PREFETCHABLE MEMORY LIMIT ADDRESS REGISTER – OFFSET 24h

BIT	FUNCTION	TYPE	DESCRIPTION	EEPROM/ I2C-SMBUS	DEFAULT
19:16	64-bit addressing	RO	Read as 1h to indicate 64-bit addressing.	No	1h
31:20	Memory Limit Address [31:20]	RW	Defines the top address of an address range for the Bridge to determine when to forward memory transactions from one interface to the other. The upper 12 bits correspond to address bits [31:20] and are writable. The lower 20 bits corresponding to address bits [19:0] are assumed to be FFFFh.	No/Yes	000h

### 8.2.23 PREFETCHABLE MEMORY BASE ADDRESS UPPER 32-BITS REGISTER – OFFSET 28h

BIT	FUNCTION	TYPE	DESCRIPTION	EEPROM/ I2C-SMBUS	DEFAULT
31:0	Prefetchable Memory Base Address, Upper 32-bits [63:32]	RW	Defines the upper 32-bits of a 64-bit bottom address of an address range for the Bridge to determine when to forward memory read and write transactions from one interface to the other.	No/Yes	0000_0000h

### 8.2.24 PREFETCHABLE MEMORY LIMIT ADDRESS UPPER 32-BITS REGISTER – OFFSET 2Ch

BIT	FUNCTION	TYPE	DESCRIPTION	EEPROM/ I2C-SMBUS	DEFAULT
31:0	Prefetchable Memory Limit Address, Upper 32-bits [63:32]	RW	Defines the upper 32-bits of a 64-bit top address of an address range for the Bridge to determine when to forward memory read and write transactions from one interface to the other.	No/Yes	0000_0000h

### 8.2.25 I/O BASE ADDRESS UPPER 16-BITS REGISTER – OFFSET 30h

BIT	FUNCTION	TYPE	DESCRIPTION	EEPROM/ I2C-SMBUS	DEFAULT
15:0	I/O Base Address, Upper 16-bits [31:16]	RW	Defines the upper 16-bits of a 32-bit bottom address of an address range for the Bridge to determine when to forward I/O transactions from one interface to the other.	No/Yes	0000h

### 8.2.26 I/O LIMIT ADDRESS UPPER 16-BITS REGISTER – OFFSET 30h

BIT	FUNCTION	TYPE	DESCRIPTION	EEPROM/ I2C-SMBUS	DEFAULT
31:16	I/O Limit Address, Upper 16-bits [31:16]	RW	Defines the upper 16-bits of a 32-bit top address of an address range for the Bridge to determine when to forward I/O transactions from one interface to the other.	No/Yes	0000h

### 8.2.27 CAPABILITY POINTER REGISTER – OFFSET 34h

BIT	FUNCTION	TYPE	DESCRIPTION	EEPROM/ I2C-SMBUS	DEFAULT
7:0	Capability Pointer	RO	Indicates next capability pointer.	Yes	40h

### 8.2.28 INTERRUPT LINE REGISTER – OFFSET 3Ch

BIT	FUNCTION	TYPE	DESCRIPTION	EEPROM/ I2C-SMBUS	DEFAULT
7:0	Interrupt Line	RW	Indicates the Interrupt Line.	No/Yes	00h

### 8.2.29 INTERRUPT PIN REGISTER – OFFSET 3Ch

BIT	FUNCTION	TYPE	DESCRIPTION	EEPROM/ I2C-SMBUS	DEFAULT
15:8	Interrupt Pin	RO	The Switch implements INTA virtual wire interrupt signals to represent hot-plug events at downstream ports.  0b: disable INTA 1b: enable INTA	Yes	00h for Up 01h for Down

### 8.2.30 BRIDGE CONTROL REGISTER – OFFSET 3Ch

BIT	FUNCTION	TYPE	DESCRIPTION	EEPROM/ I2C-SMBUS	DEFAULT
16	Parity Error Response	RW	0b: Ignore Poisoned TLPs on the secondary interface 1b: Enable the Poisoned TLPs reporting and detection on the secondary interface	No/Yes	0
17	S_SERR# Enable	RW	0b: Disables the forwarding of EER_COR, ERR_NONFATAL and ERR_FATAL from secondary to primary interface 1b: Enables the forwarding of EER_COR, ERR_NONFATAL and ERR_FATAL from secondary to primary interface	No/Yes	0
18	ISA Enable	RW	0b: Forwards downstream all I/O addresses in the address range defined by the I/O Base, I/O Base, and Limit registers 1b: Forwards upstream all I/O addresses in the address range defined by the I/O Base and Limit registers that are in the first 64KB of PCI I/O address space (top 768 bytes of each 1KB block)	No/Yes	0
19	VGA Enable	RW	0b: Ignores access to the VGA memory or IO address range 1b: Forwards transactions targeted at the VGA memory or IO address range  VGA memory range starts from 000A 0000h to 000B FFFFh VGA IO addresses are in the first 64KB of IO address space. AD [9:0] is in the ranges 3B0 to 3BBh and 3C0h to 3DFh.	No/Yes	0
20	VGA 16-bit Decode	RW	0b: Executes 10-bit address decoding on VGA I/O accesses 1b: Executes 16-bit address decoding on VGA I/O accesses	No/Yes	0
21	Master Abort Mode	RsvdP	Not Support.	No	0

BIT	FUNCTION	TYPE	DESCRIPTION	EEPROM/ I2C-SMBUS	DEFAULT
22	Secondary Bus Reset	RW	0b: Does not trigger a hot reset on the corresponding PCI Express Port 1b: Triggers a hot reset on the corresponding PCI Express Port  At the downstream port, it asserts PORT_RST# to the attached downstream device.  At the upstream port, it asserts the PORT_RST# at all the downstream ports.	No/Yes	0
23	Fast Back-to-Back Enable	RsvdP	Not Support.	No	0
24	Primary Master Timeout	RsvdP	Not Support.	No	0
25	Secondary Master Timeout	RsvdP	Not Support.	No	0
26	Master Timeout Status	RsvdP	Not Support.	No	0
27	Discard Timer SERR# Enable	RsvdP	Not Support.	No	0
31:28	Reserved	RsvdP	Not Support.	No	0h

### 8.2.31 POWER MANAGEMENT CAPABILITIES REGISTER – OFFSET 40h

BIT	FUNCTION	TYPE	DESCRIPTION	EEPROM/ I2C-SMBUS	DEFAULT
7:0	Enhanced Capabilities ID	RO	Read as 01h to indicate that these are power management enhanced capability registers.	No	01h
15:8	Next Item Pointer	RO	Indicates next capability pointer.	Yes	48h
18:16	Power Management Revision	RO	Read as 011b to indicate the device is compliant to Revision 1.2 of <i>PCI Power Management Interface Specifications</i> .	No	011b
19	PME# Clock	RO	Does not apply to PCI Express. Must be hardwired to 0.	No	0
20	Reserved	RsvdP	Not Support.	No	0
21	Device specific Initialization	RO	Read as 0b to indicate Switch does not have device specific initialization requirements.	Yes	0
24:22	AUX Current	RO	Reset to 000b.	Yes	000b
25	D1 Power State Support	RO	Read as 0b to indicate Switch does not support the D1 power management state.	Yes	0
26	D2 Power State Support	RO	Read as 0b to indicate Switch does not support the D2 power management state.	Yes	0
31:27	PME# Support	RO	Read as 19h to indicate Switch supports the forwarding of PME# message in D0, D3 and D4 states.	Yes	19h

### 8.2.32 POWER MANAGEMENT DATA REGISTER – OFFSET 44h

BIT	FUNCTION	TYPE	DESCRIPTION	EEPROM/ I2C-SMBUS	DEFAULT
1:0	Power State	RW	Indicates the current power state of the Switch. Writing a value of D0 when the previous state was D3 cause a hot reset without asserting DWN_RST_L.  00b: D0 state 01b: D1 state 10b: D2 state 11b: D3 hot state	No/Yes	00b
2	Reserved	RsvdP	Not Support.	No	0
3	No_Soft_Reset	RO	When set, this bit indicates that device transitioning from D3hot to D0 does not perform an internal reset. When clear, an internal reset is performed when power state transits from D3hot to D0.	Yes	1
7:4	Reserved	RsvdP	Not Support.	No	0h

BIT	FUNCTION	TYPE	DESCRIPTION	EEPROM/ I2C-SMBUS	DEFAULT
8	PME# Enable	RW	When asserted, the Switch will generate the PME# message.	No/Yes	0
12:9	Data Select	RW / RO	Select data registers. RW if offset 870h[1]=1 and RO if offset 870h[1]=0.	No/Yes	0h
14:13	Data Scale	RO	Reset to 00b.	No	00b
15	PME Status	RW1C	Read as 0b as the PME# message is not implemented.	No	0

### 8.2.33 PPB SUPPORT EXTENSIONS REGISTER – OFFSET 44h

BIT	FUNCTION	TYPE	DESCRIPTION	EEPROM/ I2C-SMBUS	DEFAULT
21:16	Reserved	RsvdP	Not Support.	No	00h
22	B2_B3 Support for D3 <sub>HOT</sub>	RsvdP	Not Support.	No	0
23	Bus Power / Clock Control Enable	RsvdP	Not Support.	No	0

### 8.2.34 DATA REGISTER– OFFSET 44h

BIT	FUNCTION	TYPE	DESCRIPTION	EEPROM/ I2C-SMBUS	DEFAULT
31:24	Data Register	RO	Data Register.	Yes	00h

### 8.2.35 MSI CAPABILITIES REGISTER – OFFSET 48h

BIT	FUNCTION	TYPE	DESCRIPTION	EEPROM/ I2C-SMBUS	DEFAULT
7:0	Enhanced Capabilities ID	RO	Read as 05h to indicate that this is message signal interrupt capability register.	No	05h
15:8	Next Item Pointer	RO	Indicates next capability pointer.	Yes	68h
16	MSI Enable	RW	0b: The function is prohibited from using MSI to request service 1b: The function is permitted to use MSI to request service and is prohibited from using its INTx # pin	No/Yes	0
19:17	Multiple Message Capable	RO	Read as 000b.	No	000b
22:20	Multiple Message Enable	RW	Reset to 000b.	No/Yes	000b
23	64-bit address capable	RO	0b: The function is not capable of generating a 64-bit message address 1b: The function is capable of generating a 64-bit message address	No	1b
31:24	Reserved	RO	Not Support.	No	00h

### 8.2.36 MESSAGE ADDRESS REGISTER – OFFSET 4Ch

BIT	FUNCTION	TYPE	DESCRIPTION	EEPROM/ I2C-SMBUS	DEFAULT
1:0	Reserved	RsvdP	Not Support.	No	00b
31:2	Message Address	RW	If the message enable bit is set, the contents of this register specify the DWORD aligned address for MSI memory write transaction.	No/Yes	0-0h

### 8.2.37 MESSAGE UPPER ADDRESS REGISTER – OFFSET 50h

BIT	FUNCTION	TYPE	DESCRIPTION	EEPROM/ I2C-SMBUS	DEFAULT
31:0	Message Upper Address	RW	This register is only effective if the device supports a 64-bit message address is set.	No/Yes	0000_0000h

### 8.2.38 MESSAGE DATA REGISTER – OFFSET 54h

BIT	FUNCTION	TYPE	DESCRIPTION	EEPROM/ I2C-SMBUS	DEFAULT
15:0	Message Data	RW	Message data.	No/Yes	0000h

### 8.2.39 PCI EXPRESS CAPABILITIES REGISTER – OFFSET 68h

BIT	FUNCTION	TYPE	DESCRIPTION	EEPROM/ I2C-SMBUS	DEFAULT
7:0	Enhanced Capabilities ID	RO	Read as 10h to indicate that these are PCI express enhanced capability registers.	No	10h
15:8	Next Item Pointer	RO	Indicates next capability pointer.	Yes	A4h
19:16	Capability Version	RO	Read as 2h to indicate the device is compliant to Revision .2.0 of <i>PCI Express Base Specifications</i> .	No	2h
23:20	Device/Port Type	RO	Indicates the type of PCI Express logical device. 0101b: upstream port 0110b: downstream port	No	5h for Up 6h for Down
24	Slot Implemented	RO	Valid for downstream ports only. When set, indicates that the PCIe Link associated with this Port is connected to a slot. This field is valid for downstream ports of the Switch.	Yes	0 for Up 1 for Down
29:25	Interrupt Message Number	RO	No MSI messages are generated in the transparent mode.	No	00_000b
31:30	Reserved	RsvdP	Not Support.	No	00b

### 8.2.40 DEVICE CAPABILITIES REGISTER – OFFSET 6Ch

BIT	FUNCTION	TYPE	DESCRIPTION	EEPROM/ I2C-SMBUS	DEFAULT
2:0	Max_Payload_Size Supported	RO	Indicates the maximum payload size that the device can support for TLPs. 000b: 128 payload size 001b: 256 payload size 010b: 512 payload size	Yes	001b
4:3	Phantom Functions Supported	RO	Indicates the support for use of unclaimed function numbers as Phantom functions. Read as 00b, since the Switch does not act as a requester.	No	00b
5	Extended Tag Field Supported	RO	Indicates the maximum supported size of Tag field as a Requester. Read as 0, since the Switch does not act as a requester.	No	0
8:6	Endpoint L0s Acceptable Latency	RO	Acceptable total latency that an Endpoint can withstand due to the transition from L0s state to the L0 state. For Switch, the ASPM software would not check this value.	No	000b
11:9	Endpoint L1 Acceptable Latency	RO	Acceptable total latency that an Endpoint can withstand due to the transition from L1 state to the L0 state. For Switch, the ASPM software would not check this value.	No	000b
14:12	Reserved	RsvdP	Not Support.	No	000b

BIT	FUNCTION	TYPE	DESCRIPTION	EEPROM/ I2C-SMBUS	DEFAULT
15	Role_Based Error Reporting	RO	When set, indicates that the device implements the functionality originally defined in the Error Reporting ECN.	Yes	1
17:16	Reserved	RsvdP	Not Support.	No	00b
25:18	Captured Slot Power Limit Value	RO	It applies to Upstream Port only.  In combination with the Slot Power Limit Scale value, specifies the upper limit on power supplied by slot.  This value is set by the Set_Slot_Power_Limit message or hardwired to 0.	No	00h
27:26	Captured Slot Power Limit Scale	RO	It applies to Upstream Port only.  Specifies the scale used for the Slot Power Limit Value.  This value is set by the Set_Slot_Power_Limit message or hardwired to 0.	No	00b
31:28	Reserved	RsvdP	Not Support.	No	0h

### 8.2.41 DEVICE CONTROL REGISTER – OFFSET 70h

BIT	FUNCTION	TYPE	DESCRIPTION	EEPROM/ I2C-SMBUS	DEFAULT
0	Correctable Error Reporting Enable	RW	0b: Disable Correctable Error Reporting 1b: Enable Correctable Error Reporting	No/Yes	0
1	Non-Fatal Error Reporting Enable	RW	0b: Disable Non-Fatal Error Reporting 1b: Enable Non-Fatal Error Reporting	No/Yes	0
2	Fatal Error Reporting Enable	RW	0b: Disable Fatal Error Reporting 1b: Enable Fatal Error Reporting	No/Yes	0
3	Unsupported Request Reporting Enable	RW	0b: Disable Unsupported Request Reporting 1b: Enable Unsupported Request Reporting	No/Yes	0
4	Enable Relaxed Ordering	RO	When set, it permits the device to set the Relaxed Ordering bit in the attribute field of transaction. Since the Switch can not either act as a requester or alter the content of packet it forwards, this bit always returns '0' when read.	No	0
7:5	Max_Payload_Size	RW	This field sets maximum TLP payload size for the device. Permissible values that can be programmed are indicated by the Max_Payload_Size Supported in the Device Capabilities register. Any value exceeding the Max_Payload_Size Supported written to this register results into clamping to the Max_Payload_Size Supported value.	No/Yes	000b
8	Extended Tag Field Enable	RW	Does not apply to PCI Express Switch. Returns '0' when read.	No	0
9	Phantom Function Enable	RW	Does not apply to PCI Express Switch. Returns '0' when read.	No	0
10	Auxiliary (AUX) Power PM Enable	RO	When set, indicates that a device is enabled to draw AUX power independent of PME AUX power.	No	0
11	Enable No Snoop	RO	When set, it permits to set the No Snoop bit in the attribute field of transaction. Since the Switch can not either act as a requester or alter the content of packet it forwards, this bit always returns '0' when read.	No	0
14:12	Max_Read_Request_Size	RO	This field sets the maximum Read Request size for the device as a Requester. Since the Switch does not generate read request by itself, these bits are hardwired to 0.	No	000b
15	Reserved	RsvdP	Not Support.	No	0



### 8.2.42 DEVICE STATUS REGISTER – OFFSET 70h

BIT	FUNCTION	TYPE	DESCRIPTION	EEPROM/ I2C-SMBUS	DEFAULT
16	Correctable Error Detected	RWIC	Asserted when correctable error is detected. Errors are logged in this register regardless of whether error reporting is enabled or not in the Device Control register.	No/Yes	0
17	Non-Fatal Error Detected	RWIC	Asserted when non-fatal error is detected. Errors are logged in this register regardless of whether error reporting is enabled or not in the Device Control register.	No/Yes	0
18	Fatal Error Detected	RWIC	Asserted when fatal error is detected. Errors are logged in this register regardless of whether error reporting is enabled or not in the Device Control register.	No/Yes	0
19	Unsupported Request Detected	RWIC	Asserted when unsupported request is detected. Errors are logged in this register regardless of whether error reporting is enabled or not in the Device Control register.	No/Yes	0
20	AUX Power Detected	RO	Asserted when the AUX power is detected by the Switch	No	0
21	Transactions Pending	RO	Each port of Switch does not issue Non-posted Requests on its own behalf, so this bit is hardwired to 0.	No	0
31:22	Reserved	RsvdP	Not Support.	No	0-0h

### 8.2.43 LINK CAPABILITIES REGISTER – OFFSET 74h

BIT	FUNCTION	TYPE	DESCRIPTION	EEPROM/ I2C-SMBUS	DEFAULT
3:0	Maximum Link Speed	RO	Indicates the maximum speed of the Express link. 0001b: 2.5 Gb/s 0010b: 5.0 Gb/s Others: Reserved	No	2h
9:4	Maximum Link Width	HWInt RO	Indicates the maximum width of the given PCIe Link. 00_0001b: x1 link 00_0100b: x4 link Others: Reserved	No	04h or 01h
11:10	Active State Power Management (ASPM) Support	RO	Indicates the level of ASPM supported on the given PCIe Link. Each port of Switch supports L0s and L1 entry.	Yes	01b
14:12	L0s Exit Latency	RO	Indicates the L0s exit latency for the given PCIe Link. The length of time this port requires to complete transition from L0s to L0 is in the range of 256ns to less than 512ns.	Yes	011b
17:15	L1 Exit Latency	RO	Indicates the L1 exit latency for the given PCIe Link. The length of time this port requires to complete transition from L1 to L0 is less than 1us.	Yes	000b
18	Clock Power Management	RO	For upstream port, a value of 1b indicates that component tolerates the removal of any reference clock via CLKREQ#. For downstream ports, this bit must be hardwired to 0.	Yes	1 for Up 0 for Down
19	Surprise Down Capability Enable	RO	Valid for downstream ports only.	Yes	0
20	Data Link Layer Active Reporting Capable	RO	For downstream ports, this bit must be set to 1b if the component supports the optional capability of reporting the DL_Active state of the Data Link Control and Management State Machine. For a hot-plug capable downstream port, this bit must be set to 1b. For upstream port, this bit must be hardwired to 0.	No	0
21	Link BW Notify Cap.	RO	Valid for downstream ports only.	Yes	0 for Up 1 for Down
23:22	Reserved	RsvdP	Not Support.	No	0

BIT	FUNCTION	TYPE	DESCRIPTION	EEPROM/ I2C-SMBUS	DEFAULT
31:24	Port Number	RO	Indicates the PCIe Port Number for the given PCIe Link.	Yes	00h for Up 01 h for Port 1 02h for Port 2 03h for Port 3 ....

### 8.2.44 LINK CONTROL REGISTER – OFFSET 78h

BIT	FUNCTION	TYPE	DESCRIPTION	EEPROM/ I2C-SMBUS	DEFAULT
1:0	Active State Power Management (ASPM) Control	RW	00b: ASPM is Disabled 01b: L0s Entry Enabled 10b: L1 Entry Enabled 11b: L0s and L1 Entry Enabled  Note that the receiver must be capable of entering L0s even when the field is disabled	No/Yes	00b
2	Reserved	RsvdP	Not Support.	No	0
3	Read Completion Boundary (RCB)	RsvdP	Not Support.	No	0
4	Link Disable	RW	At upstream port, it is not allowed to disable the link, so this bit is hardwired to '0'. For downstream ports, it disables the link when this bit is set.	No/Yes	0
5	Retrain Link	RW	At upstream port, it is not allowed to retrain the link, so this bit is hardwired to 0. For downstream ports, it initiates Link Retraining when this bit is set.  This bit always returns '0' when read.	No/Yes	0
6	Common Clock Configuration	RW	0b: The components at both ends of a link are operating with synchronous reference clock 1b: The components at both ends of a link are operating with a distributed common reference clock	No/Yes	0
7	Extended Synch	RW	When set, it transmits 4096 FTS ordered sets in the L0s state for entering L0 state and transmits 1024 TS1 ordered sets in the L1 state for entering L0 state.	No/Yes	0
8	Enable Clock Power Management	RW	Valid for upstream port only- 0b: clock power management is disabled and must hold CLKREQ# low 1b: device is permitted to use CLKREQ# to power manage Link clock	No/Yes	0
9	HW Autonomous Width Disable	RW	Reset to 0b.	No/Yes	0
10	Link Bandwidth Management Interrupt Enable	RW	Valid for downstream ports only.	No/Yes	0
11	Link Autonomous Bandwidth Interrupt Enable	RW	Valid for downstream ports only.	No/Yes	0
15:12	Reserved	RsvdP	Not Support.	No	0h

### 8.2.45 LINK STATUS REGISTER – OFFSET 78h

BIT	FUNCTION	TYPE	DESCRIPTION	EEPROM/ I2C-SMBUS	DEFAULT
19:16	Link Speed	RO	Indicate the negotiated speed of the Express link. 0001b: 2.5 Gb/s 0010b: 5.0 Gb/s	No	1h

BIT	FUNCTION	TYPE	DESCRIPTION	EEPROM/ I2C-SMBUS	DEFAULT
25:20	Negotiated Link Width	RO	Indicates the negotiated width of the given PCIe link. 00_0001b: x1 link 00_0010b: x2 link 00_0100b: x4 link	No	00_0001b
26	Training Error	RO	When set, indicates a Link training error occurred. This bit is cleared by hardware upon successful training of the link to the L0 link state.	No	0
27	Link Training	RO	When set, indicates the link training is in progress. Hardware clears this bit once link training is complete.	No	0
28	Slot Clock Configuration	RO	0b: the Switch uses an independent clock irrespective of the presence of a reference on the connector 1b: the Switch uses the same reference clock that the platform provides on the connector	Yes	1 for Up 0 for Down
29	Data Link Layer Link Active	RO	Indicates the status of the Data Link Control and Management State Machine. 1b: indicate the DL_Active state 0b: otherwise	No	0
30	Link Bandwidth Management Status	RW1C	Valid for downstream port only.	No/Yes	0
31	Link Autonomous Bandwidth Status	RW1C	Valid for downstream port only.	No/Yes	0

### 8.2.46 SLOT CAPABILITIES REGISTER – OFFSET 7Ch (Downstream Port Only)

BIT	FUNCTION	TYPE	DESCRIPTION	EEPROM/ I2C-SMBUS	DEFAULT
0	Attention Button Present	RO	When set, it indicates that an Attention Button is implemented on the chassis for this slot.	Yes	1
1	Power Controller Present	RO	When set, it indicates that a Power Controller is implemented for this slot.	Yes	1
2	MRL Sensor Present	RO	When set, this bit indicates that an MRL Sensor is implemented on the chassis for this slot.	Yes	1
3	Attention Indicator Present	RO	When set, it indicates that an Attention Indicator is implemented on the chassis for this slot	Yes	1
4	Power Indicator Present	RO	When set, it indicates that a Power Indicator is implemented on the chassis for this slot.	Yes	1
5	Hot-Plug Surprise	RO	When set, it indicates that a device present in this slot might be removed from the system without any prior notification.	Yes	0
6	Hot-Plug Capable	HWInt RO	When set, it indicates that this slot is capable of supporting Hot-Plug operation. Without external I/O expander connected, the default value will be clear to 0.	Yes	0
14:7	Slot Power Limit Value	RO	In combination with the Slot Power Limit Scale value, specifies the upper limit on power supplied by slot. Writes to this register also cause the Port to send the Set_Slot_Power_Limit message.	Yes	19h
16:15	Slot Power Limit Scale	RO	Specifies the scale used for the Slot Power Limit Value. Writes to this register also cause the Port to send the Set_Slot_Power_Limit message.	Yes	00b
17	EM_INTRELOCK Present	RO	When set, it indicates that an Electromechanical Interlock Present is implemented on the chassis for this slot.	Yes	0
18	No Command Completed Support	RO	When set, it indicates that this slot does not generate software notification when an issued command is completed by the Hot-Plug Controller.	Yes	0
31:19	Physical Slot Number	RO	It indicates the physical slot number attached to this Port.	Yes	01 h for Port 1 04h for Port 4 05h for Port 5 ...

### 8.2.47 SLOT CONTROL REGISTER – OFFSET 80h (Downstream Port Only)

BIT	FUNCTION	TYPE	DESCRIPTION	EEPROM/ I2C-SMBUS	DEFAULT
0	Attention Button Pressed Enable	RW	When set, it enables the generation of Hot-Plug interrupt or wakeup event on an attention button pressed event.	No/Yes	0
1	Power Fault Detected Enable	RW	When set, it enables the generation of Hot-Plug interrupt or wakeup event on a power fault event.	No/Yes	0
2	MRL SENOR ENABLE	RW	When set, it enables the generation of Hot-Plug interrupt or wakeup event on a MRL sensor event.	No/Yes	0
3	Presence Detect Changed Enable	RW	When set, it enables the generation of Hot-Plug interrupt or wakeup event on a presence detect changed event.	No/Yes	0
4	Command Completed Interrupt Enable	RW	When set, it enables the generation of Hot-Plug interrupt when the Hot-Plug Controller completes a command. It is valid when offset 7Ch[18]=0b.	No/Yes	0
5	Hot-Plug Interrupt Enable	RW	When set, it enables generation of Hot-Plug interrupt on enabled Hot-Plug events.	No/Yes	0
7:6	Attention Indicator Control	RW	Controls the display of Attention Indicator.  00b: Reserved 01b: On 10b: Blink 11b: Off  Writes to this register also cause the Port to send the ATTENTION INDICATOR * Messages.	No/Yes	11b
9:8	Power Indicator Control	RW	Controls the display of Power Indicator.  00b: Reserved 01b: On 10b: Blink 11b: Off  Writes to this register also cause the Port to send the POWER INDICATOR * Messages.	No/Yes	11b when bit[2]=1 01b when bit[2]=0
10	Power Controller Control	RW	0b: reset the power state of the slot (Power On) 1b: set the power state of the slot (Power Off)	No/Yes	1 when bit[2]=1 0 when bit[2]=0
11	EM_INTRELOCK Control	RW	When set, it enables the generation of Hot-Plug interrupt or wakeup event on an electromechanical interlock present event.	No/Yes	0
12	Data Link Layer State Changed Enable	RW	When set, it enables the generation of Hot-Plug interrupt or wakeup event on a data link layer state changed event.	No/Yes	0
15:13	Reserved	RsvdP	Not Support.	No	000b

### 8.2.48 SLOT STATUS REGISTER – OFFSET 80h (Downstream Port Only)

BIT	FUNCTION	TYPE	DESCRIPTION	EEPROM/ I2C-SMBUS	DEFAULT
16	Attention Button Pressed	RW1C	When set, it indicates the Attention Button is pressed.	No/Yes	0
17	Power Fault Detected	RW1C	When set, it indicates a Power Fault is detected.	No/Yes	0
18	MRL Sensor Changed	RW1C	When set, it indicates a MRL Sensor Changed is detected.	No/Yes	0
19	Presence Detect Changed	RW1C	When set, it indicates a Presence Detect Changed is detected.	No/Yes	0
20	Command Completed	RW1C	When set, it indicates the Hot-Plug Controller completes an issued command.	No/Yes	0
21	MRL Sensor State	RO	Reflects the status of MRL Sensor.  0b: MRL Closed 1b: MRL Opened	No	0

BIT	FUNCTION	TYPE	DESCRIPTION	EEPROM/ I2C-SMBUS	DEFAULT
22	Presence Detect State	RO	Indicates the presence of a card in the slot.  0b: Slot Empty 1b: Card Present in slot  This register is implemented on all downstream ports that implement slots. For downstream ports not connected to slots (where the Slot Implemented bit of the PCI Express Capabilities register is 0b), this bit returns 1b.	No	0
23	EM_INTRELOCK Status	RO	Indicates the Electromechanical Interlock's current status.  0b: Electromechanical Interlock is disengaged 1b: Electromechanical Interlock is engaged	No	0
24	Data Link Layer State Changed	RW1C	This bit is set when the value reported in the Data Link Layer Link Active field of the Link Status register is changed.	No/Yes	0
31:25	Reserved	RsvdP	Not Support.	No	0-0h

#### 8.2.49 DEVICE CAPABILITIES REGISTER 2 – OFFSET 8Ch

BIT	FUNCTION	TYPE	DESCRIPTION	EEPROM/ I2C-SMBUS	DEFAULT
4:0	Reserved	RsvdP	Not Support.	No	0_0000b
5	ARI Forwarding Supported	RO	0b: ARI forwarding is not supported 1b: ARI forwarding is supported  Valid for downstream ports only.	No/Yes	0 for Up 1 for Down
31:6	Reserved	RsvdP	Not Support.	No	0-0h

#### 8.2.50 DEVICE CONTROL REGISTER 2 – OFFSET 90h

BIT	FUNCTION	TYPE	DESCRIPTION	EEPROM/ I2C-SMBUS	DEFAULT
4:0	Reserved	RsvdP	Not Support.	No	0_0000b
5	ARI Forwarding Enable	RW	0b: Disable 1b: Enable  Valid for downstream ports only.	No/Yes	0
31:6	Reserved	RsvdP	Not Support.	No	0-0h

#### 8.2.51 DEVICE STATUS REGISTER 2 – OFFSET 90h

BIT	FUNCTION	TYPE	DESCRIPTION	EEPROM/ I2C-SMBUS	DEFAULT
31:16	Device Status 2	RO	Not Support.	No	0000h

#### 8.2.52 LINK CAPABILITIES REGISTER 2 – OFFSET 94h

BIT	FUNCTION	TYPE	DESCRIPTION	EEPROM/ I2C-SMBUS	DEFAULT
31:0	Link Capability 2	RO	Not Support.	No	0000_0000h

### 8.2.53 LINK CONTROL REGISTER 2 – OFFSET 98h

BIT	FUNCTION	TYPE	DESCRIPTION	EEPROM/ I2C-SMBUS	DEFAULT
3:0	Target Link Speed	RW	0001b: target link speed set to 2.5 Gb/s 0010b: target link speed set to 5.0 Gb/s Others: Reserved	No/Yes	2h
4	Enter Compliance	RW	1b: enter compliance mode	No/Yes	0
5	HW_AutoSpeed_Dis	RW	Reset to 0b.	No/Yes	0
6	Select_Deemp	RW	Valid for downstream ports only. 0b: Select -6.0db de-emphasis 1b: Select -3.5db de-emphasis	Yes	0 for Up 1 for Down
9:7	Tran_Margin	RW	Reset to 000b.	No/Yes	000b
10	Enter Modify Compliance	RW	Valid for upstream port only.	No/Yes	0
11	Compliance SOS	RW	Valid for upstream port only.	No/Yes	0
12	Compliance_Deemp	RW	Valid for upstream port only.	No/Yes	0
15:13	Reserved	RsvdP	Not Support.	No	000b

### 8.2.54 LINK STATUS REGISTER 2 – OFFSET 98h

BIT	FUNCTION	TYPE	DESCRIPTION	EEPROM/ I2C-SMBUS	DEFAULT
16	Current De-emphasis level	RO	0b:current de-emphasis level is -3.5db 1b: current de-emphasis level is -6.0db	No	0 for Up 1 for Down
31:17	Reserved	RO	Not Support.	No	0-0h

### 8.2.55 SLOT CAPABILITIES REGISTER 2 – OFFSET 9Ch

BIT	FUNCTION	TYPE	DESCRIPTION	EEPROM/ I2C-SMBUS	DEFAULT
31:0	Slot Capability 2	RO	Not Support.	No	0000_0000h

### 8.2.56 SLOT CONTROL REGISTER 2 – OFFSET A0h

BIT	FUNCTION	TYPE	DESCRIPTION	EEPROM/ I2C-SMBUS	DEFAULT
15:0	Slot Control 2	RO	Not Support.	No	0000h

### 8.2.57 SLOT STATUS REGISTER 2 – OFFSET A0h

BIT	FUNCTION	TYPE	DESCRIPTION	EEPROM/ I2C-SMBUS	DEFAULT
31:16	Slot Status 2	RO	Not Support.	No	0000h

### 8.2.58 SSID/SSVID CAPATILITIES REGISTER – OFFSET A4h

BIT	FUNCTION	TYPE	DESCRIPTION	EEPROM/ I2C-SMBUS	DEFAULT
7:0	SSID/SSVID Capabilities ID	RO	Read as 0Dh to indicate that these are SSID/SSVID capability registers.	No	0Dh
15:8	Next Item Pointer	RO	Read as 00h. No other ECP registers.	Yes	00h

BIT	FUNCTION	TYPE	DESCRIPTION	EEPROM/ I2C-SMBUS	DEFAULT
31:16	Reserved	RsvdP	Not Support.	No	0000h

### 8.2.59 SUBSYSTEM VENDOR ID REGISTER – OFFSET A8h

BIT	FUNCTION	TYPE	DESCRIPTION	EEPROM/ I2C-SMBUS	DEFAULT
15:0	SSVID	RO	Indicates the sub-system vendor id.	Yes	12D8h

### 8.2.60 SUBSYSTEM ID REGISTER – OFFSET A8h

BIT	FUNCTION	TYPE	DESCRIPTION	EEPROM/ I2C-SMBUS	DEFAULT
31:16	SSID	RO	Indicates the sub-system device id.	Yes	8608h

### 8.2.61 BAR 0-1 CONFIGURATION REGISTER – OFFSET E4h (Upstream Port Only)

BIT	FUNCTION	TYPE	DESCRIPTION	EEPROM/ I2C-SMBUS	DEFAULT
1:0	BAR0 Type	RW	Decides whether BAR0 is 32 or 64 bit addressing. 00b: Disable BAR0/1 01b: Reserved 10b: 32-bit addressing 11b: 64-bit addressing	Yes	10b
2	BAR0 Prefetchable	RW	0b: Non Prefetchable 1b: Prefetchable	Yes	0
31:3	Reserved	RsvdP	Not Support.	No	0-0h

### 8.2.62 DEVICE SERIAL NUMBER ENHANCED CAPABILITY HEADER REGISTER – OFFSET 100h

BIT	FUNCTION	TYPE	DESCRIPTION	EEPROM/ I2C-SMBUS	DEFAULT
15:0	Extended Capabilities ID	RO	Read as 0003h to indicate that these are PCI express extended capability registers for device serial number extend capability register.	No	0003h
19:16	Capability Version	RO	Must be 1h for this version.	No	1h
31:20	Next Capability Offset	RO	Indicates next capability pointer.	Yes	FB4h

### 8.2.63 DEVICE SERIAL NUMBER LOWER DW REGISTER – OFFSET 104h

BIT	FUNCTION	TYPE	DESCRIPTION	EEPROM/ I2C-SMBUS	DEFAULT
31:0	Device serial number 1 <sup>st</sup> DW	RO	First dword for device serial number.	Yes	0000_0000h

### 8.2.64 DEVICE SERIAL NUMBER HIGHER DW REGISTER – OFFSET 108h

BIT	FUNCTION	TYPE	DESCRIPTION	EEPROM/ I2C-SMBUS	DEFAULT
31:0	Device serial number 2 <sup>nd</sup> DW	RO	Second dword for device serial number.	Yes	0000_0000h

### 8.2.65 PCI EXPRESS POWER BUDGETING ENHANCED CAPABILITY HEADER REGISTER – OFFSET 138h (Upstream Port Only)

BIT	FUNCTION	TYPE	DESCRIPTION	EEPROM/ I2C-SMBUS	DEFAULT
15:0	Extended Capabilities ID	RO	Read as 0004h to indicate that these are PCI express extended capability registers for power budgeting.	No	0004h
19:16	Capability Version	RO	Must be 1h for this version.	No	01h
31:20	Next Capability Offset	RO	Indicates next capability pointer.	Yes	148h

### 8.2.66 DATA SELECT REGISTER – OFFSET 13Ch (Upstream Port Only)

BIT	FUNCTION	TYPE	DESCRIPTION	EEPROM/ I2C-SMBUS	DEFAULT
7:0	Data Selection	RW	It indexes the power budgeting data reported through the data register.  When 00h, it selects D0 Max power budget When 01h, it selects D0 Sustained power budget Other values would return zero power budgets, which means not supported.	No/Yes	00h
31:8	Reserved	RsvdP	Not Support.	No	0-0h

### 8.2.67 POWER BUDGETING DATA REGISTER – OFFSET 140h (Upstream Port Only)

BIT	FUNCTION	TYPE	DESCRIPTION	EEPROM/ I2C-SMBUS	DEFAULT
7:0	Base Power	RO	It specifies the base power value in watts. This value represents the required power budget in the given operation condition.	Yes	04h if 13Ch=0 03h if 13Ch=1
9:8	Data Scale	RO	It specifies the scale to apply to the base power value.	Yes	00b
12:10	PM Sub State	RO	It specifies the power management sub state of the given operation condition. It is initialized to the default sub state.	No	000b
14:13	PM State	RO	It specifies the power management state of the given operation condition.  It defaults to the D0 power state.	Yes	00b
17:15	Type	RO	It specifies the type of the given operation condition which is controlled by offset 13Ch[7:0].  It defaults to the Maximum power state.	Yes	111b if 13Ch=0 011b if 13Ch=1
20:18	Power Rail	RO	It specifies the power rail of the given operation condition..	No	010b
31:21	Reserved	RsvdP	Not Support.	No	0-0h



### 8.2.68 POWER BUDGET CAPABILITY REGISTER – OFFSET 144h (Upstream Port Only)

BIT	FUNCTION	TYPE	DESCRIPTION	EEPROM/ I2C-SMBUS	DEFAULT
0	System Allocated	RO	When set, it indicates that the power budget for the device is included within the system power budget.	Yes	1
31:1	Reserved	RsvdP	Not Support.	No	0-0h

### 8.2.69 PCI EXPRESS VIRTUAL CHANNEL ENHANCED CAPABILITY HEADER REGISTER – OFFSET 148h

BIT	FUNCTION	TYPE	DESCRIPTION	EEPROM/ I2C-SMBUS	DEFAULT
15:0	Extended Capabilities ID	RO	Read as 0002h to indicate that these are PCI express extended capability registers for virtual channel.	No	02h
19:16	Capability Version	RO	Read as 1h.	No	01h
31:20	Next Capability Offset	RO	Indicates next capability pointer.	Yes	270h for Up 520h for Down

### 8.2.70 PORT VC CAPABILITY REGISTER 1 – OFFSET 14Ch

BIT	FUNCTION	TYPE	DESCRIPTION	EEPROM/ I2C-SMBUS	DEFAULT
2:0	Extended VC Count	RO	Indicates the number of extended Virtual Channels in addition to the default VC supported by the Switch.	Yes	000b
3	Reserved	RsvdP	Not Support.	No	0
6:4	Low Priority Extended VC Count	RO	Indicates the number of extended Virtual Channels in addition to the default VC belonging to the low-priority VC (LPVC) group.	Yes	000b
7	Reserved	RO	Not Support.	No	0
9:8	Reference Clock	RO	Indicates the reference clock for Virtual Channels that support time-based WRR Port Arbitration. Defined encoding is 00b for 100 ns reference clock.	No	00b
11:10	Port Arbitration Table Entry Size	RO	Read as 10b to indicate the size of Port Arbitration table entry in the device is 4 bits.	No	10b
31:12	Reserved	RsvdP	Not Support.	No	0000_0h

### 8.2.71 PORT VC CAPABILITY REGISTER 2 – OFFSET 150h

BIT	FUNCTION	TYPE	DESCRIPTION	EEPROM/ I2C-SMBUS	DEFAULT
7:0	VC Arbitration Capability	RO	It indicates the types of VC Arbitration supported by the device for the LPVC group. This field is valid when LPVC is greater than 0. The Switch supports Hardware fixed arbitration scheme, e.g., Round Robin and Weight Round Robin arbitration with 32 phases in LPVC.	No	00h
23:8	Reserved	RsvdP	Not Support.	No	0000h
31:24	VC Arbitration Table Offset	RO	It indicates the location of the VC Arbitration Table as an offset from the base address of the Virtual Channel Capability register in the unit of DQWD (16 bytes).	No	00h if VC1=0 04h if VC1=1

### 8.2.72 PORT VC CONTROL REGISTER – OFFSET 154h

BIT	FUNCTION	TYPE	DESCRIPTION	EEPROM/ I2C-SMBUS	DEFAULT
0	Load VC Arbitration Table	WO	When set, the programmed VC Arbitration Table is applied to the hardware. This bit always returns '0' when read.	Yes	0
3:1	VC Arbitration Select	RW	This field is used to configure the VC Arbitration by selecting one of the supported VC Arbitration schemes. The valid values for the schemes supported by Switch are 0b and 1b. Other value than these written into this register will be treated as default.	No/Yes	000b
15:4	Reserved	RsvdP	Not Support.	No	000h

### 8.2.73 PORT VC STATUS REGISTER – OFFSET 154h

BIT	FUNCTION	TYPE	DESCRIPTION	EEPROM/ I2C-SMBUS	DEFAULT
16	VC Arbitration Table Status	RO	When set, it indicates that any entry of the VC Arbitration Table is written by software. This bit is cleared when hardware finishes loading values stored in the VC Arbitration Table after the bit of "Load VC Arbitration Table" is set.	No	0
31:17	Reserved	RsvdP	Not Support.	No	0-0h

### 8.2.74 VC RESOURCE CAPABILITY REGISTER (0) – OFFSET 158h

BIT	FUNCTION	TYPE	DESCRIPTION	EEPROM/ I2C-SMBUS	DEFAULT
7:0	Port Arbitration Capability	RO	It indicates the types of Port Arbitration supported by the VC resource. The Switch supports Hardware fixed arbitration scheme, e.g., Round Robin, Weight Round Robin (WRR) arbitration with 128 phases (3~4 enabled ports) and Time-based WRR with 128 phases (3~4 enabled ports). Note that the Time-based WRR is only valid in VC1.	No	03h
13:8	Reserved	RsvdP	Not Support.	No	00_0000h
14	Advanced Packet Switching	RO	When set, it indicates the VC resource only supports transaction optimized for Advanced Packet Switching (AS).	No	0
15	Reject Snop Transactions	RsvdP	Not Support.	No	0
22:16	Maximum Time Slots	RO	It indicates the maximum numbers of time slots (minus one) are allocated for Isochronous traffic.	No	3Fh
23	Reserved	RsvdP	Not Support.	No	0
31:24	Port Arbitration Table Offset	RO	It indicates the location of the Port Arbitration Table (n) as an offset from the base address of the Virtual Channel Capability register in the unit of DQWD (16 bytes).	No	05h

### 8.2.75 VC RESOURCE CONTROL REGISTER (0) – OFFSET 15Ch

BIT	FUNCTION	TYPE	DESCRIPTION	EEPROM/ I2C-SMBUS	DEFAULT
7:0	TC/VC Map	RW	This field indicates the TCs that are mapped to the VC resource. Bit locations within this field correspond to TC values. When the bits in this field are set, it means that the corresponding TCs are mapped to the VC resource. Bit 0 of this field is read-only and must be set to "1" for the VC0.	Yes	FFh
15:8	Reserved	RsvdP	Not Support.	No	00h
16	Load Port Arbitration Table	RW	When set, the programmed Port Arbitration Table is applied to the hardware. This bit always returns '0' when read.	No/Yes	0

BIT	FUNCTION	TYPE	DESCRIPTION	EEPROM/ I2C-SMBUS	DEFAULT
19:17	Port Arbitration Select	RW	This field is used to configure the Port Arbitration by selecting one of the supported Port Arbitration schemes. The permissible values for the schemes supported by Switch are 000b and 011b at VC0, other value than these written into this register will be treated as default.	No/Yes	000b
23:20	Reserved	RsvdP	Not Support.	No	0h
26:24	VC ID	RO	This field assigns a VC ID to the VC resource.	No	000b
30:27	Reserved	RsvdP	Not Support.	No	0h
31	VC Enable	RW	0b: it disables this Virtual Channel 1b: it enables this Virtual Channel	No	1

### 8.2.76 VC RESOURCE STATUS REGISTER (0) – OFFSET 160h

BIT	FUNCTION	TYPE	DESCRIPTION	EEPROM/ I2C-SMBUS	DEFAULT
15:0	Reserved	RsvdP	Not Support.	No	0000h
16	Port Arbitration Table Status	RO	When set, it indicates that any entry of the Port Arbitration Table is written by software. This bit is cleared when hardware finishes loading values stored in the Port Arbitration Table after the bit of “Load Port Arbitration Table” is set.	No	0
17	VC Negotiation Pending	RO	When set, it indicates that the VC resource is still in the process of negotiation. This bit is cleared after the VC negotiation is complete.	No	0
31:18	Reserved	RsvdP	Not Support.	No	0-0h

### 8.2.77 VC RESOURCE CAPABILITY REGISTER (1) – OFFSET 164h

BIT	FUNCTION	TYPE	DESCRIPTION	EEPROM/ I2C-SMBUS	DEFAULT
7:0	Port Arbitration Capability	RO	It indicates the types of Port Arbitration supported by the VC resource. The Switch supports Hardware fixed arbitration scheme, e.g., Round Robin, Weight Round Robin (WRR) arbitration with 128 phases (3~4 enabled ports) and Time-based WRR with 128 phases (3~4 enabled ports). Note that the Time-based WRR is only valid in VC1.	No	00h if VC1=0 13h if VC1=1
13:8	Reserved	RsvdP	Not Support.	No	0-0h
14	Advanced Packet Switching	RO	When set, it indicates the VC resource only supports transaction optimized for Advanced Packet Switching (AS).	No	0
15	Reject Snoop Transactions	RO	This bit is not applied to PCIe Switch.	No	0
22:16	Maximum Time Slots	RO	It indicates the maximum numbers of time slots (minus one) are allocated for Isochronous traffic.	Yes	00h if VC1=0 3Fh if VC1=1
23	Reserved	RsvdP	Not Support.	No	0
31:24	Port Arbitration Table Offset	RO	It indicates the location of the Port Arbitration Table (n) as an offset from the base address of the Virtual Channel Capability register in the unit of DQWD (16 bytes).	No	00h if VC1=0 06h if VC1=1

### 8.2.78 VC RESOURCE CONTROL REGISTER (1) – OFFSET 168h

BIT	FUNCTION	TYPE	DESCRIPTION	EEPROM/ I2C-SMBUS	DEFAULT
7:0	TC/VC Map	RW	This field indicates the TCs that are mapped to the VC resource. Bit locations within this field correspond to TC values. When the bits in this field are set, it means that the corresponding TCs are mapped to the VC resource. Bit 0 of this field is read-only and must be set to “0” for the VC1.	Yes	00h
15:8	Reserved	RsvdP	Not Support.	No	00h

BIT	FUNCTION	TYPE	DESCRIPTION	EEPROM/ I2C-SMBUS	DEFAULT
16	Load Port Arbitration Table	RW	When set, the programmed Port Arbitration Table is applied to the hardware. This bit always returns 0b when read.	No/Yes	0
19:17	Port Arbitration Select	RW	This field is used to configure the Port Arbitration by selecting one of the supported Port Arbitration schemes. The permissible values for the schemes supported by Switch are 000b, 011b and 100b at VC1, other value than these written into this register will be treated as default.	No/Yes	000b
23:20	Reserved	RsvdP	Not Support.	No	0h
26:24	VC ID	RW	This field assigns a VC ID to the VC resource.	No/Yes	000b if VC1=0 001b if VC1=1
30:27	Reserved	RsvdP	Not Support.	No	0h
31	VC Enable	RW	0b: it disables this Virtual Channel 1b: it enables this Virtual Channel	No/Yes	0

### 8.2.79 VC RESOURCE STATUS REGISTER (1) – OFFSET 16Ch

BIT	FUNCTION	TYPE	DESCRIPTION	EEPROM/ I2C-SMBUS	DEFAULT
15:0	Reserved	RsvdP	Not Support.	No	0000h
16	Port Arbitration Table Status	RO	When set, it indicates that any entry of the Port Arbitration Table is written by software. This bit is cleared when hardware finishes loading values stored in the Port Arbitration Table after the bit of “Load Port Arbitration Table” is set.	No	0
17	VC Negotiation Pending	RO	When set, it indicates that the VC resource is still in the process of negotiation. This bit is cleared after the VC negotiation is complete.	No	0
31:18	Reserved	RsvdP	Not Support.	No	0-0h

### 8.2.80 VC ARBITRATION TABLE REGISTER – OFFSET 188h

The VC arbitration table is a read-write register array that contains a table for VC arbitration. Each table entry allocates four bits, of which three bits are used to represent VC ID and one bit is reserved. A total of 32 entries are used to construct the VC arbitration table. The layout for this register array is shown below.

**Table 8-2 Register Array Layout for VC Arbitration**

31 - 28	27 - 24	23 - 20	19 - 16	15 - 12	11 - 8	7 - 4	3 - 0	Byte Location	EEPROM/ I2C-SMBUS	DEFAULT
Phase [7]	Phase [6]	Phase [5]	Phase [4]	Phase [3]	Phase [2]	Phase [1]	Phase [0]	00h	No/Yes	0000_0000h
Phase [15]	Phase [14]	Phase [13]	Phase [12]	Phase [11]	Phase [10]	Phase [9]	Phase [8]	04h	No/Yes	0000_0000h
Phase [23]	Phase [22]	Phase [21]	Phase [20]	Phase [19]	Phase [18]	Phase [17]	Phase [16]	08h	No/Yes	0000_0000h
Phase [31]	Phase [30]	Phase [29]	Phase [28]	Phase [27]	Phase [26]	Phase [25]	Phase [24]	0Ch	No/Yes	0000_0000h

### 8.2.81 PORT ARBITRATION TABLE REGISTER (0) and (1) – OFFSET 198h and 1A8h

The Port arbitration table is a read-write register array that contains a table for Port arbitration. Each table entry allocates two bits to represent Port Number. The table entry size is dependent on the number of enabled ports (refer to bit 10 and 11 of Port VC capability register 1). The arbitration table contains 32 entries if three or four ports are to be enabled. The following table shows the register array layout for the size of entry equal to two.

**Table 8-3 Table Entry Size in 4 Bits**

31 - 24	23 - 16	15 - 8	7 - 0	Byte Location	EEPROM/I2C-SMBUS	DEFAULT
Phase [7:6]	Phase [5:4]	Phase [3:2]	Phase [1:0]	00h	No/Yes	0000_0000h
Phase [15:14]	Phase [13:12]	Phase [11:10]	Phase [9:8]	04h	No/Yes	0000_0000h
Phase [23:22]	Phase [21:20]	Phase [19:18]	Phase [17:16]	08h	No/Yes	0000_0000h
Phase [31:30]	Phase [29:28]	Phase [27:26]	Phase [25:24]	0Ch	No/Yes	0000_0000h

### 8.2.82 ECC ERROR CHECK DISABLE REGISTER – OFFSET 1C8h (Global)

BIT	FUNCTION	TYPE	DESCRIPTION	EEPROM/I2C-SMBUS	DEFAULT
3:0	Reserved	RW	Test used only.	No/Yes	000
4	Enable INTA_L for Hot Plug or Link State Event	RW	0b: Send an INTx Message for Hot Plug or Link State Event 1b: Assert INTA_L for Hot Plug or Link State Event	No/Yes	0
5	Reserved	RW	Test used only.	No/Yes	0
6	Enable INTA_L for GPIO-Generated Interrupts	RW	0b: Send an INTx Message for GPIO Interrupt Requests 1b: Assert INTA_L for GPIO Interrupt Requests	No/Yes	0
7	Enable INTA_L for NT Virtual Doorbell-Generated Interrupts	RW	0b: Send an INTx Message for NT Virtual Doorbell Interrupt Requests 1b: Assert INTA_L for NT Virtual Doorbell Interrupt Requests	No/Yes	0
31: 8	Reserved	RsvdP	Not Support.	No	0-0h

### 8.2.83 NT-UP PORT SELECTION REGISTER – OFFSET 1DCh (Global)

BIT	FUNCTION	TYPE	DESCRIPTION	EEPROM/I2C-SMBUS	DEFAULT
7:0	Reserved	RsvdP	Not Support.	No	00h
9:8	UP_PORT_SEL	HwInt RW	Used to select Upstream Port when Bit[15]=1.	No/Yes	0h
14:10	Reserved	RsvdP	Not Support.	No	0_0000b
15	Software_CFG_Mode	RW	When set to 1, UP and NT Ports are decided by Bit[11:8] and Bit[27:24].	No/Yes	0
23:16	Reserved	RsvdP	Not Support.	No	00h
27:24	NT_PORT_SEL	HwInt RW	Used to select NT Port when Bit[15]=1.	No/Yes	0h
31:28	Reserved	RsvdP	Not Support.	No	0h

### 8.2.84 HOT PLUG CONFIGURATION REGISTER – OFFSET 1E0h

BIT	FUNCTION	TYPE	DESCRIPTION	EEPROM/I2C-SMBUS	DEFAULT
1:0	Reserved	RsvdP	Not Support.	No	00b
2	HPC_PME_TURN_OFF_En	RW	Valid for downstream ports only. 0b: disable to send out PME_TURN_OFF message. 1b: enable to send out PME_TURN_OFF message.	Yes	0

BIT	FUNCTION	TYPE	DESCRIPTION	EEPROM/ I2C-SMBUS	DEFAULT
4:3	HPC_Timer	RW	Valid for downstream ports only. Used to set hot plug port timer.  00b: Reserved 01b: 128 ms 10b: 256 ms 11b: 512 ms	Yes	01b
5	Reserved	RsvdP	Not Support.	No	0
6	HPC_PG_ActiveLow_En	RW	Valid for downstream ports only.  0b: PWR_GOODx pins are Active high. 1b: PWR_GOODx pins are Active low.	Yes	0
11:7	Reserved	RsvdP	Not Support.	No	0-0h
12	NT_Serial_HotPlug_En	RW	Valid for NT port only.  0b: disable serial hot plug capability on NT port. 1b: enable serial hot plug capability on NT port.	No	0
14:7	Reserved	RsvdP	Not Support.	No	0-0h
15	IOE_Cmd_In_Progress	RO	Indicates that the Write command to an IOE (I/O Expander) GPIOx Output Data register is still in progress.	No	0
16	HPC_Serial_HotPlug_Disable	RW	Valid for upstream port only.  0b: enable serial hot plug capability for all downstream ports. 1b: disable serial hot plug capability for all downstream ports.	Yes	0
17	IOE_40Bit_En	RW	Valid for upstream port only.  0b: enable 16-pin IOE for all downstream ports. 1b: enable 40-pin IOE for all downstream ports.	Yes	0
18	HPC_GPIO_Dir	RW	0b: set GPIO direction to input pin 1b: set GPIO direction to output pin	Yes	0
19	HPC_GPIO_Value	RW	I/O Expander GPIO Value.	Yes	0
20	HPC_I/O_Reload	RW	1b: the value of Hotplug Controller Output pin is reloaded. This bit is self clearing.	Yes	0
26:21	HPC_Output_Reload_Value	RW	When Bit [20] is set, values from this field are reloaded.	Yes	000b
31:27	Reserved	RsvdP	Not Support.	No	0000_0b

### 8.2.85 SOFTWARE LANE STATUS REGISTER – OFFSET 1F4h (Global)

BIT	FUNCTION	TYPE	DESCRIPTION	EEPROM/ I2C-SMBUS	DEFAULT
31:0	Software Lane Status	RO	Indicates current lane status.  0b: link down 1b: link up  Bit[3:0]: for Lane 3 to Lane 0 Bit[11:8]: for Lane 7 to Lane 4 Others: Reserved	No	0000_0000h

### 8.2.86 DE-EMPHASIS AND RATE CONTROL REGISTER – OFFSET 208h (Upstream Port Only)

BIT	FUNCTION	TYPE	DESCRIPTION	EEPROM/ I2C-SMBUS	DEFAULT
15:0	Rate Ctrl	RW	Test used only.  0h: GEN1 speed 1h: GEN2 speed	No/Yes	0000h

31:16	De-emphasis Ctrl	RW	Test used only. 0h: -6 dB 1h: -3.5 dB	No/Yes	0000h
-------	------------------	----	---	--------	-------

### 8.2.87 COMPLIANCE MODE CONTROL REGISTER – OFFSET 20Ch

BIT	FUNCTION	TYPE	DESCRIPTION	EEPROM/ I2C-SMBUS	DEFAULT
15:0	Compliance Mode	RW	Test used only. 1h: enter Compliance mode	No/Yes	0000h
31:16	Reserved	RsvdP	Not Support.	No	0000h

### 8.2.88 EVEN PORT PHYSICAL LAYER COMMAND AND STATUS REGISTER – OFFSET 220h (Global)

BIT	FUNCTION	TYPE	DESCRIPTION	EEPROM/ I2C-SMBUS	DEFAULT
0	PORT0_Loopback_CMD	RW	Test used only.	No/Yes	0
1	PORT0_Scramble_Disable_CMD	RW	Test used only.	No/Yes	0
2	PORT0_Compliance_Receive	RW	Test used only.	No/Yes	0
7:3	Reserved	RsvdP	Not Support.	No	00h
8	PORT4_Loopback_CMD	RW	Test used only.	No/Yes	0
9	PORT4_Scramble_Disable_CMD	RW	Test used only.	No/Yes	0
10	PORT4_Compliance_Receive	RW	Test used only.	No/Yes	0
11	Reserved	RsvdP	Not Support.	No	0
12	PORT6_Loopback_CMD	RW	Test used only.	No/Yes	0
13	PORT6_Scramble_Disable_CMD	RW	Test used only.	No/Yes	0
14	PORT6_Compliance_Receive	RW	Test used only.	No/Yes	0
15	Reserved	RsvdP	Not Support.	No	0
16	PORT8_Loopback_CMD	RW	Test used only.	No/Yes	0
17	PORT8_Scramble_Disable_CMD	RW	Test used only.	No/Yes	0
18	PORT8_Compliance_Receive	RW	Test used only.	No/Yes	0
31:19	Reserved	RsvdP	Not Support.	No	0000h

### 8.2.89 ODD PORT PHYSICAL LAYER COMMAND AND STATUS REGISTER – OFFSET 224h (Global)

BIT	FUNCTION	TYPE	DESCRIPTION	EEPROM/ I2C-SMBUS	DEFAULT
0	PORT1_Loopback_CMD	RW	Test used only.	No/Yes	0
1	PORT1_Scramble_Disable_CMD	RW	Test used only.	No/Yes	0

BIT	FUNCTION	TYPE	DESCRIPTION	EEPROM/ I2C-SMBUS	DEFAULT
2	PORT1_Combpliance_Receive	RW	Test used only.	No/Yes	0
7:3	Reserved	RsvdP	Not Support.	No	00h
8	PORT5_Loopback_CMD	RW	Test used only.	No/Yes	0
9	PORT5_Scramble_Disable_CMD	RW	Test used only.	No/Yes	0
10	PORT5_Combpliance_Receive	RW	Test used only.	No/Yes	0
11	Reserved	RsvdP	Not Support.	No	0
12	PORT7_Loopback_CMD	RW	Test used only.	No/Yes	0
13	PORT7_Scramble_Disable_CMD	RW	Test used only.	No/Yes	0
14	PORT7_Combpliance_Receive	RW	Test used only.	No/Yes	0
15	Reserved	RsvdP	Not Support.	No	0
16	PORT9_Loopback_CMD	RW	Test used only.	No/Yes	0
17	PORT9_Scramble_Disable_CMD	RW	Test used only.	No/Yes	0
18	PORT9_Combpliance_Receive	RW	Test used only.	No/Yes	0
31:19	Reserved	RsvdP	Not Support.	No	0000h

### 8.2.90 EVEN PORT DISABLE/QUIET/TEST PATTERN RATE REGISTER – OFFSET 230h (Global)

BIT	FUNCTION	TYPE	DESCRIPTION	EEPROM/ I2C-SMBUS	DEFAULT
7:0	Even Port Disable	RW	0b: enable LTSSM operation. 1b: force LTSSM in the Detect.Quiet state.  Bit[0]: for Port 0 Bit[2]: for Port 4 Bit[3]: for Port 6 Bit[4]: for Port 8 Others: Reserved	No/Yes	00h
15:8	Even Port Quiet	RW	0b: LTSSM is allowed to exit the Detect.Quiet state 1b: LTSSM remains in the Detect.Quiet state  Bit[0]: for Port 0 Bit[2]: for Port 4 Bit[3]: for Port 6 Bit[4]: for Port 8 Others: Reserved	No/Yes	00h
23:16	Even Port Test Pattern Rate	RW	Test used only.	No/Yes	00h
31:24	Reserved	RsvdP	Not Support.	No	00h



### 8.2.91 ODD PORT DISABLE/QUIET/TEST PATTERN RATE REGISTER – OFFSET 234h (Global)

BIT	FUNCTION	TYPE	DESCRIPTION	EEPROM/ I2C-SMBUS	DEFAULT
7:0	Odd Port Disable	RW	0b: enable LTSSM operation 1b: force LTSSM in the Detect.Quiet state  Bit[0]: for Port 1 Bit[2]: for Port 5 Bit[3]: for Port 7 Bit[4]: for Port 9 Others: Reserved	No/Yes	00h
15:8	Odd Port Quiet	RW	0b: LTSSM is allowed to exit the Detect.Quiet state 1b: LTSSM remains in the Detect.Quiet state  Bit[0]: for Port 1 Bit[2]: for Port 5 Bit[3]: for Port 7 Bit[4]: for Port 9 Others: Reserved	No/Yes	00h
23:16	Odd Port Test Pattern Rate	RW	Test used only.	No/Yes	00h
31:24	Reserved	RsvdP	Not Support.	No	00h

### 8.2.92 LI PM SUBSTATES ENHANCED CAPABILITY HEADER – OFFSET 270h

BIT	FUNCTION	TYPE	DESCRIPTION	EEPROM/ I2C-SMBUS	DEFAULT
15:0	PCI Express Extended Capability ID	RO	Read as 001Eh to indicate PCI Express Extended Capability ID for L1 PM Substates Extended Capability.	No	001Eh
19:16	Capability Version	RO	Must be 1h for this version.	No	1h
31:20	Next Capability Offset	RO	Indicates next capability pointer.	Yes	900h

### 8.2.93 L1 PM SUBSTATES CAPABILITY REGISTER – OFFSET 274h

BIT	FUNCTION	TYPE	DESCRIPTION	EEPROM/ I2C-SMBUS	DEFAULT
0	Reserved	RsvdP	Not Support.	No	0
1	PCI-PM L1.1 Supported	RO	When set this bit indicates that PCI-PM L1.1 is supported and must be set by all ports implementing L1 PM Substates.	Yes	1
2	Reserved	RO	Not Support.	No	0
3	ASPM L1.1 Supported	RO	When set this bit indicates that ASPM L1.1 is supported.	Yes	0
4	L1 PM Substates Supported	RO	When set this bit indicates that this port supports L1 PM Substates.	Yes	1
31:5	Reserved	RsvdP	Not Support.	No	0-0h

### 8.2.94 L1 PM SUBSTATES CONTROL 1 REGISTER – OFFSET 278h

BIT	FUNCTION	TYPE	DESCRIPTION	EEPROM/ I2C-SMBUS	DEFAULT
0	Reserved	RsvdP	Not Support.	No	0
1	PCI-PM L1.1 Enable	RW	When set this bit enables PCI-PM L1.1. Required for both upstream and downstream ports.	No/Yes	0

BIT	FUNCTION	TYPE	DESCRIPTION	EEPROM/ I2C-SMBUS	DEFAULT
2	Reserved	RsvdP	Not Support.	No	0
3	ASPM L1.1 Enable	RW	When set this bit enables ASPM L1.1. Required for both upstream and downstream ports.	No/Yes	0
31:4	Reserved	RsvdP	Not Support.	No	0-0h

### 8.2.95 L1 PM SUBSTATES CONTROL 2 REGISTER – OFFSET 27Ch

BIT	FUNCTION	TYPE	DESCRIPTION	EEPROM/ I2C-SMBUS	DEFAULT
31:0	Reserved	RsvdP	Not Support.	No	0000_0000h

### 8.2.96 SMBUS CONTROL AND STATUS REGISTER – OFFSET 344h (Upstream Port Only)

BIT	FUNCTION	TYPE	DESCRIPTION	EEPROM/ I2C-SMBUS	DEFAULT
0	SMBus Enable	HWInt RW	0b: disable SMBUS, enable I2C 1b: enable SMBUS	No/Yes	0
7:1	SMBUS Address	HwInt RW	Set SMBUS Address. Bit [3:1] are decided by the status of strapped pins (GPIO[7:5]).	No/Yes	0111_000b
8	ARP Disable	RW	Test used only.	No/Yes	1
9	PEC Check Disable	RW	0b: enable PEC check 1b: disable PEC check	No/Yes	1
10	AV Flag	RW	Test used only.	No/Yes	0
11	AR Flag	RW	Test used only.	No/Yes	0
13:12	UDID Addr Type	RW	Test used only.	No/Yes	00b
14	UDID PEC Support	RW	Test used only.	No/Yes	1
15	Reserved	RsvdP	Not Support.	No	0
23:16	UDID Vendor ID	RW	Test used only.	No/Yes	B0h
26:24	UDID Revision ID	RW	Test used only.	No/Yes	001b
27	Fty Test 0	RW	Test used only.	No/Yes	0
28	SMBUS In Progress	RO	0b: SMBUS interface is idle. 1b: SMBUS interface is busy.	No	0
29	PEC Check Fail	RO	0b: PEC check successfully 1b: PEC check failed	No	0
30	Unsupported SMBUS Command	RO	0b: supported command. 1b: unsupported command.	No	0
31	Reserved	RO	Not Support.	No	1

### 8.2.97 DISABLE DOWNSTREAM PORT HOT RESET REGISTER – OFFSET 34Ch (Upstream Port Only)

BIT	FUNCTION	TYPE	DESCRIPTION	EEPROM/ I2C-SMBUS	DEFAULT
0	DN_Hot_Reset_Dis	RW	Disable downstream port hot reset.	Yes	0
31:1	Reserved	RsvdP	Not Support.	No	0-0h

### 8.2.98 ACS ENHANCED CAPABILITY HEADER REGISTER – OFFSET 520h (Downstream Port Only)

BIT	FUNCTION	TYPE	DESCRIPTION	EEPROM/ I2C-SMBUS	DEFAULT
-----	----------	------	-------------	----------------------	---------

BIT	FUNCTION	TYPE	DESCRIPTION	EEPROM/ I2C-SMBUS	DEFAULT
15:0	PCI Express Extended Capability ID	RO	Read as 000Dh to indicate PCI Express Extended Capability ID for ACS Extended Capability.	No	0Dh
19:16	Capability Version	RO	Must be 1h for this version.	No	1h
31:20	Next Capability Offset	RO	Indicates next capability pointer.	Yes	270h

### 8.2.99 ACS CAPABILITY REGISTER – OFFSET 524h (Downstream Port Only)

BIT	FUNCTION	TYPE	DESCRIPTION	EEPROM/ I2C-SMBUS	DEFAULT
0	ACS Source Validation	RO	Indicates the implements of ACS Source Validation.	No	1
1	ACS Translation Blocking	RO	Indicates the implements of ACS Translation Blocking.	No	1
2	ACS P2P Request Redirect	RO	Indicates the implements of ACS P2P Request Redirect.	No	1
3	ACS P2P Completion Redirect	RO	Indicates the implements of ACS P2P Completion Redirect	No	1
4	ACS Upstream Forwarding	RO	Indicates the implements of ACS Upstream Forwarding.	No	1
5	ACS P2P Egress control	RO	Indicates the implements of ACS P2P Egress control.	No	1
6	ACS Direct Translated P2P	RO	Indicates the implements of ACS Direct Translated P2P.	No	1
7	Reserved	RsvdP	Not Support.	No	0
15:8	Egress Control Vector Size	RO	Encodings 01h – FFh directly indicate the number of applicable bits in the Egress Control Vector.	No	10h
16	ACS Source Validation Enable	RW	0b: disable the source validation 1b: enable the source validation	No/Yes	0
17	ACS Translation Blocking Enable	RW	0b: disable ACS translation blocking 1b: enable ACS translation blocking	No/Yes	0
18	ACS P2P Request Redirect	RW	0b: disable ACS P2P request redirect 1b: enable ACS P2P request redirect	No/Yes	0
19	ACS P2P Completion Redirect Enable	RW	0b: disable ACS P2P completion redirect 1b: enable ACS P2P completion redirect	No/Yes	0
20	ACS Upstream Forwarding Enable	RW	0b: disable ACS upstream forwarding 1b: enables ACS upstream forwarding	No/Yes	0
21	ACS P2P Egress control Enable	RW	0b: disable ACS P2P egress control 1b: enable ACS P2P egress control	No/Yes	0
22	ACS Direct Translated P2P Enable	RW	0b: disable ACS direct translated P2P 1b: enable ACS Direct Translated P2P	No/Yes	0
31:23	Reserved	RsvdP	Not Support.	No	00h

### 8.2.100 EGRESS CONTROL VECTOR REGISTER – OFFSET 528h (Downstream Port Only)

BIT	FUNCTION	TYPE	DESCRIPTION	EEPROM/ I2C-SMBUS	DEFAULT
15:0	Egress Control Vector	RW	When a given bit is set, peer-to-peer requests targeting the associated Port are blocked or redirected.	No/Yes	0000h
31:16	Reserved	RsvdP	Not Support.	No	0000h

### 8.2.101 GPIO 0-15 DIRECTION CONTROL REGISTER – OFFSET 62Ch (Upstream Port Only)

BIT	FUNCTION	TYPE	DESCRIPTION	EEPROM/ I2C-SMBUS	DEFAULT
0	GPIO[0] Source/Destination	RW	As Input: 0b: Input Data Register (offset 63Ch[0]) 1b: General Interrupt (INTx, MSI or PEX_INTA#) As Output: 0b: From GPIO[0] Output Data register (offset 644h[0]) 1b: Serial Hot Plug PERST# output for Hot Plug Port 0	No/Yes	0
1	GPIO[0] Direction Control	RW	0b: Input 1b: Output	No/Yes	0
2	GPIO[1] Source/Destination	RW	As Input: 0b: Input Data Register (offset 63Ch[1]) 1b: General Interrupt (INTx, MSI or PEX_INTA#) As Output: 0b: From GPIO[1] Output Data register (offset 644h[1]) 1b: Serial Hot Plug PERST# output for Hot Plug Port 1	No/Yes	0
3	GPIO[1] Direction Control	RW	0b: Input 1b: Output	No/Yes	0
4	GPIO[2] Source/Destination	RW	As Input: 0b: Input Data Register (offset 63Ch[2]) 1b: General Interrupt (INTx, MSI or PEX_INTA#) As Output: 0b: From GPIO[2] Output Data register (offset 644h[2]) 1b: Serial Hot Plug PERST# output for Hot Plug Port 2	No/Yes	0
5	GPIO[2] Direction Control	RW	0b: Input 1b: Output	No/Yes	0
6	GPIO[3] Source/Destination	RW	As Input: 0b: Input Data Register (offset 63Ch[3]) 1b: General Interrupt (INTx, MSI or PEX_INTA#) As Output: 0b: From GPIO[3] Output Data register (offset 644h[3]) 1b: Serial Hot Plug PERST# output for Hot Plug Port 3	No/Yes	0
7	GPIO[3] Direction Control	RW	0b: Input 1b: Output	No/Yes	0
8	GPIO[4] Source/Destination	RW	As Input: 0b: Input Data Register (offset 63Ch[4]) 1b: General Interrupt (INTx, MSI or PEX_INTA#) As Output: 0b: From GPIO[4] Output Data register (offset 644h[4]) 1b: Serial Hot Plug PERST# output for Hot Plug Port 4	No/Yes	0
9	GPIO[4] Direction Control	RW	0b: Input 1b: Output	No/Yes	0
10	GPIO[5] Source/Destination	RW	As Input: 0b: Input Data Register (offset 63Ch[5]) 1b: General Interrupt (INTx, MSI or PEX_INTA#) As Output: 0b: From GPIO[5] Output Data register (offset 644h[5]) 1b: Serial Hot Plug PERST# output for Hot Plug Port 5	No/Yes	0
11	GPIO[5] Direction Control	RW	0b: Input 1b: Output	No/Yes	0
12	GPIO[6] Source/Destination	RW	As Input: 0b: Input Data Register (offset 63Ch[6]) 1b: General Interrupt (INTx, MSI or PEX_INTA#) As Output: 0b: From GPIO[6] Output Data register (offset 644h[6]) 1b: Serial Hot Plug PERST# output for Hot Plug Port 6	No/Yes	0
13	GPIO[6] Direction Control	RW	0b: Input 1b: Output	No/Yes	0

BIT	FUNCTION	TYPE	DESCRIPTION	EEPROM/ I2C-SMBUS	DEFAULT
14	GPIO[7] Source/Destination	RW	As Input: 0b: Input Data Register (offset 63Ch[7]) 1b: General Interrupt (INTx, MSI or PEX_INTA#) As Output: 0b: From GPIO[7] Output Data register (offset 644h[7]) 1b: Serial Hot Plug PERST# output for Hot Plug Port 7	No/Yes	0
15	GPIO[7] Direction Control	RW	0b: Input 1b: Output	No/Yes	0
16	GPIO[8] Source/Destination	RW	As Input: 0b: Input Data Register (offset 63Ch[8]) 1b: General Interrupt (INTx, MSI or PEX_INTA#) As Output: 0b: From GPIO[8] Output Data register (offset 644h[8]) 1b: Serial Hot Plug PERST# output for Hot Plug Port 8	No/Yes	0
17	GPIO[8] Direction Control	RW	0b: Input 1b: Output	No/Yes	0
18	GPIO[9] Source/Destination	RW	As Input: 0b: Input Data Register (offset 63Ch[9]) 1b: General Interrupt (INTx, MSI or PEX_INTA#) As Output: 0b: From GPIO[9] Output Data register (offset 644h[9]) 1b: Serial Hot Plug PERST# output for Hot Plug Port 9	No/Yes	0
19	GPIO[9] Direction Control	RW	0b: Input 1b: Output	No/Yes	0
20	GPIO[10] Source/Destination	RW	As Input: 0b: Input Data Register (offset 63Ch[10]) 1b: General Interrupt (INTx, MSI or PEX_INTA#) As Output: 0b: From GPIO[10] Output Data register (offset 644h[10]) 1b: Serial Hot Plug PERST# output for Hot Plug Port 10	No/Yes	0
21	GPIO[10] Direction Control	RW	0b: Input 1b: Output	No/Yes	0
22	GPIO[11] Source/Destination	RW	As Input: 0b: Input Data Register (offset 63Ch[11]) 1b: General Interrupt (INTx, MSI or PEX_INTA#) As Output: 0b: From GPIO[11] Output Data register (offset 644h[11]) 1b: Serial Hot Plug PERST# output for Hot Plug Port 11	No/Yes	0
23	GPIO[11] Direction Control	RW	0b: Input 1b: Output	No/Yes	0
24	GPIO[12] Source/Destination	RW	As Input: 0b: Input Data Register (offset 63Ch[12]) 1b: General Interrupt (INTx, MSI or PEX_INTA#) As Output: 0b: From GPIO[12] Output Data register (offset 644h[12]) 1b: Serial Hot Plug PERST# output for Hot Plug Port 12	No/Yes	0
25	GPIO[12] Direction Control	RW	0b: Input 1b: Output	No/Yes	0
26	GPIO[13] Source/Destination	RW	As Input: 0b: Input Data Register (offset 63Ch[13]) 1b: General Interrupt (INTx, MSI or PEX_INTA#) As Output: 0b: From GPIO[13] Output Data register (offset 644h[13]) 1b: Serial Hot Plug PERST# output for Hot Plug Port 13	No/Yes	0
27	GPIO[13] Direction Control	RW	0b: Input 1b: Output	No/Yes	0
28	GPIO[14] Source/Destination	RW	As Input: 0b: Input Data Register (offset 63Ch[14]) 1b: General Interrupt (INTx, MSI or PEX_INTA#) As Output: 0b: From GPIO[14] Output Data register (offset 644h[14]) 1b: Serial Hot Plug PERST# output for Hot Plug Port 14	No/Yes	0
29	GPIO[14] Direction Control	RW	0b: Input 1b: Output	No/Yes	0

BIT	FUNCTION	TYPE	DESCRIPTION	EEPROM/ I2C-SMBUS	DEFAULT
30	GPIO[15] Source/Destination	RW	As Input: 0b: Input Data Register (offset 63Ch[15]) 1b: General Interrupt (INTx, MSI or PEX_INTA#) As Output: 0b: From GPIO[15] Output Data register (offset 644h[15]) 1b: Serial Hot Plug PERST# output for Hot Plug Port 15	No/Yes	0
31	GPIO[15] Direction Control	RW	0b: Input 1b: Output	No/Yes	0

### 8.2.102 GPIO 16-31 DIRECTION CONTROL REGISTER – OFFSET 630h (Upstream Port Only)

BIT	FUNCTION	TYPE	DESCRIPTION	EEPROM/ I2C-SMBUS	DEFAULT
0	GPIO[16] Source/Destination	RW	As Input: 0b: Input Data Register (offset 640h[0]) 1b: General Interrupt (INTx, MSI or PEX_INTA#) As Output: 0b: From GPIO[16] Output Data register (offset 648h[0]) 1b: Reserved	No/Yes	0
1	GPIO[16] Direction Control	RW	0b: Input 1b: Output	No/Yes	0
2	GPIO[17] Source/Destination	RW	As Input: 0b: Input Data Register (offset 640h[1]) 1b: General Interrupt (INTx, MSI or PEX_INTA#) As Output: 0b: From GPIO[17] Output Data register (offset 648h[1]) 1b: Reserved	No/Yes	0
3	GPIO[17] Direction Control	RW	0b: Input 1b: Output	No/Yes	0
4	GPIO[18] Source/Destination	RW	As Input: 0b: Input Data Register (offset 640h[2]) 1b: General Interrupt (INTx, MSI or PEX_INTA#) As Output: 0b: From GPIO[18] Output Data register (offset 648h[2]) 1b: Reserved	No/Yes	0
5	GPIO[18] Direction Control	RW	0b: Input 1b: Output	No/Yes	0
6	GPIO[19] Source/Destination	RW	As Input: 0b: Input Data Register (offset 640h[3]) 1b: General Interrupt (INTx, MSI or PEX_INTA#) As Output: 0b: From GPIO[19] Output Data register (offset 648h[3]) 1b: Reserved	No/Yes	0
7	GPIO[19] Direction Control	RW	0b: Input 1b: Output	No/Yes	0
8	GPIO[20] Source/Destination	RW	As Input: 0b: Input Data Register (offset 640h[4]) 1b: General Interrupt (INTx, MSI or PEX_INTA#) As Output: 0b: From GPIO[20] Output Data register (offset 648h[4]) 1b: Reserved	No/Yes	0
9	GPIO[20] Direction Control	RW	0b: Input 1b: Output	No/Yes	0
10	GPIO[21] Source/Destination	RW	As Input: 0b: Input Data Register (offset 640h[5]) 1b: General Interrupt (INTx, MSI or PEX_INTA#) As Output: 0b: From GPIO[21] Output Data register (offset 648h[5]) 1b: Reserved	No/Yes	0
11	GPIO[21] Direction Control	RW	0b: Input 1b: Output	No/Yes	0

BIT	FUNCTION	TYPE	DESCRIPTION	EEPROM/ I2C-SMBUS	DEFAULT
12	GPIO[22] Source/Destination	RW	As Input: 0b: Input Data Register (offset 640h[6]) 1b: General Interrupt (INTx, MSI or PEX_INTA#) As Output: 0b: From GPIO[22] Output Data register (offset 648h[6]) 1b: Reserved	No/Yes	0
13	GPIO[22] Direction Control	RW	0b: Input 1b: Output	No/Yes	0
14	GPIO[23] Source/Destination	RW	As Input: 0b: Input Data Register (offset 640h[7]) 1b: General Interrupt (INTx, MSI or PEX_INTA#) As Output: 0b: From GPIO[23] Output Data register (offset 648h[7]) 1b: Reserved	No/Yes	0
15	GPIO[23] Direction Control	RW	0: Input 1: Output	No/Yes	0
16	GPIO[24] Source/Destination	RW	As Input: 0b: Input Data Register (offset 640h[8]) 1b: General Interrupt (INTx, MSI or PEX_INTA#) As Output: 0b: From GPIO[24] Output Data register (offset 648h[8]) 1b: Reserved	No/Yes	0
17	GPIO[24] Direction Control	RW	0b: Input 1b: Output	No/Yes	0
18	GPIO[25] Source/Destination	RW	As Input: 0b: Input Data Register (offset 640h[9]) 1b: General Interrupt (INTx, MSI or PEX_INTA#) As Output: 0b: From GPIO[25] Output Data register (offset 648h[9]) 1b: Reserved	No/Yes	0
19	GPIO[25] Direction Control	RW	0b: Input 1b: Output	No/Yes	0
20	GPIO[26] Source/Destination	RW	As Input: 0b: Input Data Register (offset 640h[10]) 1b: General Interrupt (INTx, MSI or PEX_INTA#) As Output: 0b: From GPIO[26] Output Data register (offset 648h[10]) 1b: Reserved	No/Yes	0
21	GPIO[26] Direction Control	RW	0b: Input 1b: Output	No/Yes	0
22	GPIO[27] Source/Destination	RW	As Input: 0b: Input Data Register (offset 640h[11]) 1b: General Interrupt (INTx, MSI or PEX_INTA#) As Output: 0b: From GPIO[27] Output Data register (offset 648h[11]) 1b: Reserved	No/Yes	0
23	GPIO[27] Direction Control	RW	0b: Input 1b: Output	No/Yes	0
24	GPIO[28] Source/Destination	RW	As Input: 0b: Input Data Register (offset 640h[12]) 1b: General Interrupt (INTx, MSI or PEX_INTA#) As Output: 0b: From GPIO[28] Output Data register (offset 648h[12]) 1b: Reserved	No/Yes	0
25	GPIO[28] Direction Control	RW	0b: Input 1b: Output	No/Yes	0
26	GPIO[29] Source/Destination	RW	As Input: 0b: Input Data Register (offset 640h[13]) 1b: General Interrupt (INTx, MSI or PEX_INTA#) As Output: 0b: From GPIO[29] Output Data register (offset 648h[13]) 1b: Reserved	No/Yes	0
27	GPIO[29] Direction Control	RW	0b: Input 1b: Output	No/Yes	0

BIT	FUNCTION	TYPE	DESCRIPTION	EEPROM/ I2C-SMBUS	DEFAULT
28	GPIO[30] Source/Destination	RW	As Input: 0b: Input Data Register (offset 640h[14]) 1b: General Interrupt (INTx, MSI or PEX_INTA#) As Output: 0b: From GPIO[30] Output Data register (offset 648h[14]) 1b: Reserved	No/Yes	0
29	GPIO[30] Direction Control	RW	0b: Input 1b: Output	No/Yes	0
30	GPIO[31] Source/Destination	RW	As Input: 0b: Input Data Register (offset 640h[15]) 1b: General Interrupt (INTx, MSI or PEX_INTA#) As Output: 0b: From GPIO[31] Output Data register (offset 648h[15]) 1b: Reserved	No/Yes	0
31	GPIO[31] Direction Control	RW	0b: Input 1b: Output	No/Yes	0

### 8.2.103 GPIO INPUT DE-BOUNCE REGISTER – OFFSET 638h (Upstream Port Only)

BIT	FUNCTION	TYPE	DESCRIPTION	EEPROM/ I2C-SMBUS	DEFAULT
31:0	GPIOx Input De- Bounce Control	RW	Controls de-bounce when the corresponding GPIOx signal is configured as an input. Bit[31:0] correspond to GPIO[31:0] respectively.  0b: GPIOx input is not de-bounced 1b: GPIOx input is de-bounced	No/Yes	0000_0000h

### 8.2.104 GPIO 0-15 INPUT DATA REGISTER – OFFSET 63Ch (Global)

BIT	FUNCTION	TYPE	DESCRIPTION	EEPROM/ I2C-SMBUS	DEFAULT
0	GPIO[0] Input Data	RO	GPIO[0] Input Data Return 0 if GPIO[0] is configured as an output (offset 62Ch[1]=1) Return the state of GPIO[0] pin if GPIO[0] is configured as an input (offset 62Ch[1]=0)	No/Yes	1
1	GPIO[1] Input Data	RO	GPIO[1] Input Data Return 0 if GPIO[1] is configured as an output (offset 62Ch[3]=1) Return the state of GPIO[1] pin if GPIO[1] is configured as an input (offset 62Ch[3]=0)	No/Yes	1
2	GPIO[2] Input Data	RO	GPIO[2] Input Data Return 0 if GPIO[2] is configured as an output (offset 62Ch[5]=1) Return the state of GPIO[2] pin if GPIO[2] is configured as an input (offset 62Ch[5]=0)	No/Yes	0
3	GPIO[3] Input Data	RO	GPIO[3] Input Data Return 0 if GPIO[3] is configured as an output (offset 62Ch[7]=1) Return the state of GPIO[3] pin if GPIO[3] is configured as an input (offset 62Ch[7]=0)	No/Yes	1
4	GPIO[4] Input Data	RO	GPIO[4] Input Data Return 0 if GPIO[4] is configured as an output (offset 62Ch[9]=1) Return the state of GPIO[4] pin if GPIO[4] is configured as an input (offset 62Ch[9]=0)	No/Yes	0
5	GPIO[5] Input Data	RO	GPIO[5] Input Data Return 0 if GPIO[5] is configured as an output (offset 62Ch[11]=1) Return the state of GPIO[5] pin if GPIO[5] is configured as an input (offset 62Ch[11]=0)	No/Yes	1
6	GPIO[6] Input Data	RO	GPIO[6] Input Data Return 0 if GPIO[6] is configured as an output (offset 62Ch[13]=1) Return the state of GPIO[6] pin if GPIO[6] is configured as an input (offset 62Ch[13]=0)	No/Yes	0



BIT	FUNCTION	TYPE	DESCRIPTION	EEPROM/ I2C-SMBUS	DEFAULT
7	GPIO[7] Input Data	RO	GPIO[7] Input Data Return 0 if GPIO[7] is configured as an output (offset 62Ch[15]=1) Return the state of GPIO[7] pin if GPIO[7] is configured as an input (offset 62Ch[15]=0)	No/Yes	1
8	GPIO[8] Input Data	RO	GPIO[8] Input Data Return 0 if GPIO[8] is configured as an output (offset 62Ch[17]=1) Return the state of GPIO[8] pin if GPIO[8] is configured as an input (offset 62Ch[17]=0)	No/Yes	0
9	GPIO[9] Input Data	RO	GPIO[9] Input Data Return 0 if GPIO[9] is configured as an output (offset 62Ch[19]=1) Return the state of GPIO[9] pin if GPIO[9] is configured as an input (offset 62Ch[19]=0)	No/Yes	1
10	GPIO[10] Input Data	RO	GPIO[10] Input Data Return 0 if GPIO[10] is configured as an output (offset 62Ch[21]=1) Return the state of GPIO[10] pin if GPIO[10] is configured as an input (offset 62Ch[21]=0)	No/Yes	0
11	GPIO[11] Input Data	RO	GPIO[11] Input Data Return 0 if GPIO[11] is configured as an output (offset 62Ch[23]=1) Return the state of GPIO[11] pin if GPIO[11] is configured as an input (offset 62Ch[23]=0)	No/Yes	1
12	GPIO[12] Input Data	RO	GPIO[12] Input Data Return 0 if GPIO[12] is configured as an output (offset 62Ch[25]=1) Return the state of GPIO[12] pin if GPIO[12] is configured as an input (offset 62Ch[25]=0)	No/Yes	0
13	GPIO[13] Input Data	RO	GPIO[13] Input Data Return 0 if GPIO[13] is configured as an output (offset 62Ch[27]=1) Return the state of GPIO[13] pin if GPIO[13] is configured as an input (offset 62Ch[27]=0)	No/Yes	1
14	GPIO[14] Input Data	RO	GPIO[14] Input Data Return 0 if GPIO[14] is configured as an output (offset 62Ch[29]=1) Return the state of GPIO[14] pin if GPIO[14] is configured as an input (offset 62Ch[29]=0)	No/Yes	0
15	GPIO[15] Input Data	RO	GPIO[15] Input Data Return 0 if GPIO[15] is configured as an output (offset 62Ch[31]=1) Return the state of GPIO[15] pin if GPIO[15] is configured as an input (offset 62Ch[31]=0)	No/Yes	1
31:16	Reserved	RsvdP	Not Support.	No	0000h

### 8.2.105 GPIO 16-31 INPUT DATA REGISTER – OFFSET 640h (Global)

BIT	FUNCTION	TYPE	DESCRIPTION	EEPROM/ I2C-SMBUS	DEFAULT
0	GPIO[16] Input Data	RO	GPIO[16] Input Data Return 0 if GPIO[16] is configured as an output (offset 630h[1]=1) Return the state of GPIO[16] pin if GPIO[16] is configured as an input (offset 630h[1]=0)	No/Yes	0
1	GPIO[17] Input Data	RO	GPIO[17] Input Data Return 0 if GPIO[17] is configured as an output (offset 630h[3]=1) Return the state of GPIO[17] pin if GPIO[17] is configured as an input (offset 630h[3]=0)	No/Yes	1
2	GPIO[18] Input Data	RO	GPIO[18] Input Data Return 0 if GPIO[18] is configured as an output (offset 630h[5]=1) Return the state of GPIO[18] pin if GPIO[18] is configured as an input (offset 630h[5]=0)	No/Yes	0

BIT	FUNCTION	TYPE	DESCRIPTION	EEPROM/ I2C-SMBUS	DEFAULT
3	GPIO[19] Input Data	RO	GPIO[19] Input Data Return 0 if GPIO[19] is configured as an output (offset 630h[7]=1) Return the state of GPIO[19] pin if GPIO[19] is configured as an input (offset 630h[7]=0)	No/Yes	1
4	GPIO[20] Input Data	RO	GPIO[20] Input Data Return 0 if GPIO[20] is configured as an output (offset 630h[9]=1) Return the state of GPIO[20] pin if GPIO[20] is configured as an input (offset 630h[9]=0)	No/Yes	0
5	GPIO[21] Input Data	RO	GPIO[21] Input Data Return 0 if GPIO[21] is configured as an output (offset 630h[11]=1) Return the state of GPIO[21] pin if GPIO[21] is configured as an input (offset 630h[11]=0)	No/Yes	1
6	GPIO[22] Input Data	RO	GPIO[22] Input Data Return 0 if GPIO[22] is configured as an output (offset 630h[13]=1) Return the state of GPIO[22] pin if GPIO[22] is configured as an input (offset 630h[13]=0)	No/Yes	0
7	GPIO[23] Input Data	RO	GPIO[23] Input Data Return 0 if GPIO[23] is configured as an output (offset 630h[15]=1) Return the state of GPIO[23] pin if GPIO[23] is configured as an input (offset 630h[15]=0)	No/Yes	1
8	GPIO[24] Input Data	RO	GPIO[24] Input Data Return 0 if GPIO[24] is configured as an output (offset 630h[17]=1) Return the state of GPIO[24] pin if GPIO[24] is configured as an input (offset 630h[17]=0)	No/Yes	0
9	GPIO[25] Input Data	RO	GPIO[25] Input Data Return 0 if GPIO[25] is configured as an output (offset 630h[19]=1) Return the state of GPIO[25] pin if GPIO[25] is configured as an input (offset 630h[19]=0)	No/Yes	1
10	GPIO[26] Input Data	RO	GPIO[26] Input Data Return 0 if GPIO[26] is configured as an output (offset 630h[21]=1) Return the state of GPIO[26] pin if GPIO[26] is configured as an input (offset 630h[21]=0)	No/Yes	0
11	GPIO[27] Input Data	RO	GPIO[27] Input Data Return 0 if GPIO[27] is configured as an output (offset 630h[23]=1) Return the state of GPIO[27] pin if GPIO[27] is configured as an input (offset 630h[23]=0)	No/Yes	1
12	GPIO[28] Input Data	RO	GPIO[28] Input Data Return 0 if GPIO[28] is configured as an output (offset 630h[25]=1) Return the state of GPIO[28] pin if GPIO[28] is configured as an input (offset 630h[25]=0)	No/Yes	0
13	GPIO[29] Input Data	RO	GPIO[29] Input Data Return 0 if GPIO[29] is configured as an output (offset 630h[27]=1) Return the state of GPIO[29] pin if GPIO[29] is configured as an input (offset 630h[27]=0)	No/Yes	1
14	GPIO[30] Input Data	RO	GPIO[30] Input Data Return 0 if GPIO[30] is configured as an output (offset 630h[29]=1) Return the state of GPIO[30] pin if GPIO[30] is configured as an input (offset 630h[29]=0)	No/Yes	0
15	GPIO[31] Input Data	RO	GPIO[31] Input Data Return 0 if GPIO[31] is configured as an output (offset 630h[31]=1) Return the state of GPIO[31] pin if GPIO[31] is configured as an input (offset 630h[31]=0)	No/Yes	1
31:16	Reserved	RsvdP	Not Support.	No/Yes	0000h

### 8.2.106 GPIO 0-15 OUTPUT DATA REGISTER – OFFSET 644h (Upstream Port Only)

BIT	FUNCTION	TYPE	DESCRIPTION	EEPROM/ I2C-SMBUS	DEFAULT
0	GPIO[0] Output Data	RW	GPIO[0] Output Data The value written to this bit is driven to GPIO[0] output if GPIO[0] is configured as an output (offset 62Ch[1]=1)	No/Yes	0

BIT	FUNCTION	TYPE	DESCRIPTION	EEPROM/ I2C-SMBUS	DEFAULT
1	GPIO[1] Output Data	RW	GPIO[1] Output Data The value written to this bit is driven to GPIO[1] output if GPIO[1] is configured as an output (offset 62Ch[3]=1)	No/Yes	0
2	GPIO[2] Output Data	RW	GPIO[2] Output Data The value written to this bit is driven to GPIO[2] output if GPIO[2] is configured as an output (offset 62Ch[5]=1)	No/Yes	0
3	GPIO[3] Output Data	RW	GPIO[3] Output Data The value written to this bit is driven to GPIO[3] output if GPIO[3] is configured as an output (offset 62Ch[7]=1)	No/Yes	0
4	GPIO[4] Output Data	RW	GPIO[4] Output Data The value written to this bit is driven to GPIO[4] output if GPIO[4] is configured as an output (offset 62Ch[9]=1)	No/Yes	0
5	GPIO[5] Output Data	RW	GPIO[5] Output Data The value written to this bit is driven to GPIO[5] output if GPIO[5] is configured as an output (offset 62Ch[11]=1)	No/Yes	0
6	GPIO[6] Output Data	RW	GPIO[6] Output Data The value written to this bit is driven to GPIO[6] output if GPIO[6] is configured as an output (offset 62Ch[13]=1)	No/Yes	0
7	GPIO[7] Output Data	RW	GPIO[7] Output Data The value written to this bit is driven to GPIO[7] output if GPIO[7] is configured as an output (offset 62Ch[15]=1)	No/Yes	0
8	GPIO[8] Output Data	RW	GPIO[8] Output Data The value written to this bit is driven to GPIO[8] output if GPIO[8] is configured as an output (offset 62Ch[17]=1)	No/Yes	0
9	GPIO[9] Output Data	RW	GPIO[9] Output Data The value written to this bit is driven to GPIO[9] output if GPIO[9] is configured as an output (offset 62Ch[19]=1)	No/Yes	0
10	GPIO[10] Output Data	RW	GPIO[10] Output Data The value written to this bit is driven to GPIO[10] output if GPIO[10] is configured as an output (offset 62C[21]=1)	No/Yes	0
11	GPIO[11] Output Data	RW	GPIO[11] Output Data The value written to this bit is driven to GPIO[11] output if GPIO[11] is configured as an output (offset 62Ch[23]=1)	No/Yes	0
12	GPIO[12] Output Data	RW	GPIO[12] Output Data The value written to this bit is driven to GPIO[12] output if GPIO[12] is configured as an output (offset 62Ch[25]=1)	No/Yes	0
13	GPIO[13] Output Data	RW	GPIO[13] Output Data The value written to this bit is driven to GPIO[13] output if GPIO[13] is configured as an output (offset 62Ch[27]=1)	No/Yes	0
14	GPIO[14] Output Data	RW	GPIO[14] Output Data The value written to this bit is driven to GPIO[14] output if GPIO[14] is configured as an output (offset 62Ch[29]=1)	No/Yes	0
15	GPIO[15] Output Data	RW	GPIO[15] Output Data The value written to this bit is driven to GPIO[15] output if GPIO[15] is configured as an output (offset 62Ch[31]=1)	No/Yes	0
31:16	Reserved	RsvdP	Not Support.	No	0000h

### 8.2.107 GPIO 16-31 OUTPUT DATA REGISTER – OFFSET 648h (Upstream Port Only)

BIT	FUNCTION	TYPE	DESCRIPTION	EEPROM/ I2C-SMBUS	DEFAULT
0	GPIO[16] Output Data	RW	GPIO[16] Output Data The value written to this bit is driven to GPIO[16] output if GPIO[16] is configured as an output (offset 630h[1]=1)	No/Yes	0
1	GPIO[17] Output Data	RW	GPIO[17] Output Data The value written to this bit is driven to GPIO[17] output if GPIO[17] is configured as an output (offset 630h[3]=1)	No/Yes	0
2	GPIO[18] Output Data	RW	GPIO[18] Output Data The value written to this bit is driven to GPIO[18] output if GPIO[18] is configured as an output (offset 630h[5]=1)	No/Yes	0

BIT	FUNCTION	TYPE	DESCRIPTION	EEPROM/ I2C-SMBUS	DEFAULT
3	GPIO[19] Output Data	RW	GPIO[19] Output Data The value written to this bit is driven to GPIO[19] output if GPIO[19] is configured as an output (offset 630h[7]=1)	No/Yes	0
4	GPIO[20] Output Data	RW	GPIO[20] Output Data The value written to this bit is driven to GPIO[20] output if GPIO[20] is configured as an output (offset 630h[9]=1)	No/Yes	0
5	GPIO[21] Output Data	RW	GPIO[21] Output Data The value written to this bit is driven to GPIO[21] output if GPIO[21] is configured as an output (offset 630h[11]=1)	No/Yes	0
6	GPIO[22] Output Data	RW	GPIO[22] Output Data The value written to this bit is driven to GPIO[22] output if GPIO[22] is configured as an output (offset 630h[13]=1)	No/Yes	0
7	GPIO[23] Output Data	RW	GPIO[23] Output Data The value written to this bit is driven to GPIO[23] output if GPIO[23] is configured as an output (offset 630h[15]=1)	No/Yes	0
8	GPIO[24] Output Data	RW	GPIO[24] Output Data The value written to this bit is driven to GPIO[24] output if GPIO[24] is configured as an output (offset 630h[17]=1)	No/Yes	0
9	GPIO[25] Output Data	RW	GPIO[25] Output Data The value written to this bit is driven to GPIO[25] output if GPIO[25] is configured as an output (offset 630h[19]=1)	No/Yes	0
10	GPIO[26] Output Data	RW	GPIO[26] Output Data The value written to this bit is driven to GPIO[26] output if GPIO[26] is configured as an output (offset 630h[21]=1)	No/Yes	0
11	GPIO[27] Output Data	RW	GPIO[27] Output Data The value written to this bit is driven to GPIO[27] output if GPIO[27] is configured as an output (offset 630h[23]=1)	No/Yes	0
12	GPIO[28] Output Data	RW	GPIO[28] Output Data The value written to this bit is driven to GPIO[28] output if GPIO[28] is configured as an output (offset 630h[25]=1)	No/Yes	0
13	GPIO[29] Output Data	RW	GPIO[29] Output Data The value written to this bit is driven to GPIO[29] output if GPIO[29] is configured as an output (offset 630h[27]=1)	No/Yes	0
14	GPIO[30] Output Data	RW	GPIO[30] Output Data The value written to this bit is driven to GPIO[30] output if GPIO[30] is configured as an output (offset 630h[29]=1)	No/Yes	0
15	GPIO[31] Output Data	RW	GPIO[31] Output Data The value written to this bit is driven to GPIO[31] output if GPIO[31] is configured as an output (offset 630h[31]=1)	No/Yes	0
31:16	Reserved	RsvdP	Not Support.	No	0000h

### 8.2.108 GPIO 0-31 INTERRUPT POLARITY REGISTER – OFFSET 64Ch (Upstream Port Only)

BIT	FUNCTION	TYPE	DESCRIPTION	EEPROM/ I2C-SMBUS	DEFAULT
31:0	GPIO Interrupt Polarity	RW	Controls whether GPIO Interrupt input is Active-Low or Active-High for the corresponding GPIOx signal. Bit[31:0] correspond to GPIO[31:0] respectively.  0b: GPIO Interrupt input is Active-Low 1b: GPIO Interrupt input is Active-High	No/Yes	0000_0000h

### 8.2.109 GPIO 0-31 INTERRUPT STATUS REGISTER – OFFSET 650h (Global)

BIT	FUNCTION	TYPE	DESCRIPTION	EEPROM/ I2C-SMBUS	DEFAULT
31:0	GPIO Interrupt Status	RO	Indicates whether GPIO interrupt are inactive or active for the corresponding GPIOx signal. Bit[31:0] correspond to GPIO[31:0]	No	5555_5554h

			respectively. 0b: GPIO interrupt is inactive 1b: GPIO interrupt is active		
--	--	--	---	--	--

### 8.2.110 GPIO 0-31 INTERRUPT MASK REGISTER – OFFSET 654h (Upstream Port Only)

BIT	FUNCTION	TYPE	DESCRIPTION	EEPROM/ I2C-SMBUS	DEFAULT
31:0	GPIO Interrupt Mask	RW	Indicates whether GPIO interrupts are masked or not masked for the corresponding GPIOx signal. Bit[31:0] correspond to GPIO[31:0] respectively. 0b: GPIO interrupt is unmasked 1b: GPIO interrupt is masked	No/Yes	0000_0000h

### 8.2.111 XPIP\_CSR 0 REGISTER – OFFSET 844h

BIT	FUNCTION	TYPE	DESCRIPTION	EEPROM/ I2C-SMBUS	DEFAULT
31:0	XPIP_CSR0	RW	XPIP_CSR 0 value. Bit[2]: Cross Link En	Yes	0400_1060h

### 8.2.112 XPIP\_CSR 1 REGISTER – OFFSET 848h

BIT	FUNCTION	TYPE	DESCRIPTION	EEPROM/ I2C-SMBUS	DEFAULT
31:0	XPIP_CSR1	RW	XPIP_CSR 1 value.	Yes	0400_0800h

### 8.2.113 DECODE VGA REGISTER – OFFSET 84Ch

BIT	FUNCTION	TYPE	DESCRIPTION	EEPROM/ I2C-SMBUS	DEFAULT
30:0	Reserved	RsvdP	Not Support.	No	0-0h
31	Decode VGA Enable	RO	0b: Disable VGA decode 1b: Enable VGA decode	Yes	1

### 8.2.114 SWITCH OPERATION MODE REGISTER – OFFSET 850h (Upstream Port Only)

BIT	FUNCTION	TYPE	DESCRIPTION	EEPROM/ I2C-SMBUS	DEFAULT
0	Store-Forward	RW	When set, a store-forward mode is used. Otherwise, the chip is working under cut-through mode.	Yes	0

BIT	FUNCTION	TYPE	DESCRIPTION	EEPROM/ I2C-SMBUS	DEFAULT
2:1	Cut-through Threshold	RW	Cut-through Threshold. When forwarding a packet from low-speed port to high-speed mode, the chip provides the capability to adjust the forwarding threshold.  00b: the threshold is set at the middle of forwarding packet 01b: the threshold is set ahead 1-cycle of middle point 10b: the threshold is set ahead 2-cycle of middle point. 11b: the threshold is set ahead 3-cycle of middle point.	Yes	01b
3	Port Arbitration Mode	RW	When set, the round-robin arbitration will stay in the arbitrated port even if the credit is not enough but request is pending. When clear, the round-robin arbitration will always go to the requesting port, which the outgoing credit is enough for the packet queued in the port.	Yes	0
4	Credit Update Mode	RW	When set, the frequency of releasing new credit to the link partner will be one credit per update. When clear, the frequency of releasing new credit to the link partner will be two credits per update.	Yes	0
5	Ordering on Different Egress Port Mode	RW	When set, there has ordering rule on packets for different egress port.	Yes	0
6	Ordering on Different Tag of Completion Mode	RW	When set, there has ordering rule between completion packet with different tag.	Yes	1
7	NonPost TLP Store-Forward	RW	When set, for Non-port TLP store-forward mode is used. Otherwise, Non-post TLP is working under cut-through mode.  When write '1', this bit is changed to '0'. When write '0', this bit is changed to '1'.	Yes	1
31:8	Reserved	RsvdP	Not Support.	No	0000 00h

### 8.2.115 XPIP\_CSR 2 REGISTER – OFFSET 854h

BIT	FUNCTION	TYPE	DESCRIPTION	EEPROM/ I2C-SMBUS	DEFAULT
7:0	FTS Number	RW	Indicates FTS number.	Yes	80h
9:8	Scrambler Control	RW	Reset to 00b.	Yes	00b
10	L0s	RW	Reset to 0b.	Yes	0
11	Compliance to Detect	RW	Reset to 0b.	Yes	0
13:12	Change Speed Sel	RW	Reset to 00b.	Yes	00b
14	Change Speed En	RW	Reset to 0b.	Yes	0
15	Reserved	RsvdP	Not Support.	No	0

### 8.2.116 PHY PARAMETER 1 REGISTER – OFFSET 854h (Upstream Port Only)

BIT	FUNCTION	TYPE	DESCRIPTION	EEPROM/ I2C-SMBUS	DEFAULT
20:16	C_EMP_POST_GE N1_3P5_NOM (Global)	RW	Set the de-emphasis level for GEN1, -3.5db. Please refer to Section 6.1.7 for more detail information.	Yes	1_0101b
25:21	C_EMP_POST_GE N2_3P5_NOM (Global)	RW	Set the de-emphasis level for GEN2, -3.5db. Please refer to Section 6.1.7 for more detail information.	Yes	10_101b
30:26	C_EMP_POST_GE N2_6P0_NOM (Global)	RW	Set the de-emphasis level for GEN2, -6.0db. Please refer to Section 6.1.7 for more detail information.	Yes	111_01b
31	Reserved	RO	Not Support.	No	0

### 8.2.117 PHY PARAMETER 2 REGISTER – OFFSET 858h

BIT	FUNCTION	TYPE	DESCRIPTION	EEPROM/ I2C-SMBUS	DEFAULT
3:0	C_TX_PHY_LATENACY (Global)	RW	Set the transmitter electrical idle latency. Please refer to Section 6.1.8 for more detail information. It is set by Upstream Port Only.	Yes	7h
6:4	C_REC_DETEC_USEC (Global)	RW	Set the receiver detection threshold. Please refer to Section 6.1.1 for more detail information. It is set by Upstream Port Only.	Yes	010b
7	Reserved	RsvdP	Not Support.	No	0
8	P_CDR_FREQLOOP_EN	RW	Reset to 0b.	Yes	1
10:9	P_CDR_THRESHOLD	RW	Reset to 01b.	Yes	10b
12:11	P_CDR_FREQLOOP_GAIN	RW	Reset to 01b.	Yes	11b
15:13	Reserved	RsvdP	Not Support.	No	000b
16	P_DRV_LVL_MGN_DELATA_EN	RW	Reset to 0b.	Yes	0
17	P_DRV_LVL_NOM_DELATA_EN	RW	Reset to 0b.	Yes	0
18	P_EMP_POST_MGN_DELATA_EN	RW	Reset to 0b.	Yes	0
19	P_EMP_POST_NOM_DELATA_EN	RW	Reset to 0b.	Yes	0
21:20	P_RX_SIGDET_LVL	RW	Set the receiver signal detection threshold. Please refer to Section 6.1.2 for more detail information.	Yes	01b
25:22	P_RX_EQ_1	RW	Set the receiver equalization for GEN1 link. Please refer to Section 6.1.3 for more detail information.	Yes	0h
29:26	P_RX_EQ_2	RW	Set the receiver equalization for GEN2 link. Please refer to Section 6.1.3 for more detail information.	Yes	0h
30	P_TXSWING	RW	Set the transmitter swing. Please refer to Section 6.1.4 for more detail information.  0b: full voltage swing with de-emphasis 1b: half voltage swing without de-emphasis	Yes	0
31	Reserved	RsvdP	Not Support.	No	0

### 8.2.118 PHY PARAMETER 3 REGISTER – OFFSET 85Ch

BIT	FUNCTION	TYPE	DESCRIPTION	EEPROM/ I2C-SMBUS	DEFAULT
6:0	PHY Parameter 3 (Per Port)	RW	PHY's Lane mode.	Yes	00h
14:7	Reserved	RsvdP	Not Support.	No	00h
31:15	PHY Parameter 3 (Global)	RW	PHY's delta value setting. It is set by Upstream Port Only.	Yes	0001h

### 8.2.119 PHY PARAMETER 4 REGISTER - OFFSET 860h (Upstream Port Only)

BIT	FUNCTION	TYPE	DESCRIPTION	EEPROM/ I2C-SMBUS	DEFAULT
14:0	PHY TX Margin Parameter (Global)	RW	PHY Tx margin parameter.	Yes	116Bh
31:15	Reserved	RsvdP	Not Support.	No	0-0h

### 8.2.120 XPIP\_CSR 3 REGISTER – OFFSET 864h

BIT	FUNCTION	TYPE	DESCRIPTION	EEPROM/ I2C-SMBUS	DEFAULT
31:0	XPIP_CSR3	RW	XPIP_CSR3 value.	Yes	000F_0000h

### 8.2.121 XPIP\_CSR 4 REGISTER – OFFSET 868h (Upstream Port Only)

BIT	FUNCTION	TYPE	DESCRIPTION	EEPROM/ I2C-SMBUS	DEFAULT
31:0	XPIP_CSR4 (Global)	RW	XPIP_CSR 4 value.	Yes	0000_0000h

### 8.2.122 XPIP\_CSR 5 REGISTER – OFFSET 86Ch

BIT	FUNCTION	TYPE	DESCRIPTION	EEPROM/ I2C-SMBUS	DEFAULT
29:0	XPIP_CSR5[29:0]	RW	Bit[10]: Default ACK Latency Timer Enable 0b: disable default ack latency timer 1b: enable default ack latency timer	Yes	3308_0008h
30	DO_CHG_DATA_RATE_CTRL	RW	DO_CHG_DATA_RATE_CTRL.	Yes	1 for Up 0 for Down
31	Gen1_Cap_Only	RW	0b: report GEN2 capability 1b: report GEN1 capability	Yes	0

### 8.2.123 NON TRANSFER MODE REGISTER – OFFSET 870h (Upstream Port Only)

BIT	FUNCTION	TYPE	DESCRIPTION	EEPROM/ I2C-SMBUS	DEFAULT
0	TX_SOF_FORM	RO	Test used only.	Yes	0
1	PM Data Select Register R/W Enable	RO	Test used only.	Yes	0
2	ARB_Abort_Sel	RO	Test used only.	Yes	1
3	4K Boundary Check Enable	RO	Test used only.	Yes	0
4	FIFOERR_FIX_SEL	RO	Test used only.	No	1
5	ORDER_RULE5 Enable	RW	Test used only.	Yes	0
6	Ordering Frozen Disable for Post Pkt	RW	Test used only.	Yes	0
7	Ordering Frozen Disable for NP Pkt	RW	Test used only.	Yes	0
11:8	Reserved	RsvdP	Not Support.	No	0h
12	ARB_VCFLG_SEL	RO	Test used only.	Yes	1
13	Reserved	RsvdP	Not Support.	No	0
14	Non-Trans_Mode	HwInt RO	Indicates the status of strapping pin NT_EN_L.	Yes	0
15	GNT_FAIL2IDLE	RO	Test used only.	Yes	1
31:16	Reserved	RsvdP	Not Support.	No	0000h



### 8.2.124 OPERATION MODE REGISTER – OFFSET 874h

BIT	FUNCTION	TYPE	DESCRIPTION	EEPROM/ I2C-SMBUS	DEFAULT
15:0	Operation Mode	HwInt RO	Bit[0]: Memory Bist Bit[1]: IDDRB Bit[2]: FAST_MODE Bit[3]: DEBUG_MODE Bit[4]: PHY_MODE Bit[6:5]: PORT_CFG[1:0] Bit[8:7]: Reserved Bit[9]: PLCSEL Bit[10]: SCAN_MODE Bit[15:11]: Reserved	No	0042h for 208 mode 0022h for 508 mode 0002h for 808 mode
23:16	Reserved	RsvdP	Not Support.	No	00h
27:24	L1PM Option	RW	Set L1PM option.	Yes	0h
31:28	Reserved	RsvdP	Not Support.	No	0h

### 8.2.125 DEVICE SPECIFIC POWER MANAGEMENT EVENT– OFFSET 878h (Downstream Port Only)

BIT	FUNCTION	TYPE	DESCRIPTION	EEPROM/ I2C-SMBUS	DEFAULT
0	Device Specific PME Capability	RO	0b: disable device specific PME. 1b: enable device specific PME.	Yes	0
1	PME Turnoff Message Request	RW	Request to send PME turnoff message.	No/Yes	0
2	Port Power	RW	Control GPIO[4:0] pins when Device Specific PME Capability is enabled. Downstream port 1 controls GPIO[0], Downstream port 2 controls GPIO[1], ... and so on. It is valid when Device Specific PME Capability is enabled.	No/Yes	1
3	Port Reset	RW	This bit when reset asserts an active low reset signal to the attached device. When set, the reset signal is de-asserted. It is valid when Device Specific PME Capability is enabled.	No/Yes	1
15:4	Reserved	RsvdP	Not Support.	No	000h
17:16	Link Status	RO	These two bits represent the link status of device connected to the downstream port. 00b: L0 01b: L0s 10b: L1 11b: L2/L3	No	00b
31:18	Reserved	RsvdP	Not Support.	No	0-0h

### 8.2.126 EEPROM CONTROL REGISTER – OFFSET 87Ch (Upstream Port Only)

BIT	FUNCTION	TYPE	DESCRIPTION	EEPROM/ I2C-SMBUS	DEFAULT
0	EEPROM Start	RW	Starts the EEPROM read or write cycle. 1b: start read or write cycle	No/Yes	0
3:1	Reserved	RsvdP	Not Support.	No	000b
4	EEPROM Autoload Status	RO	0b: EEPROM autoload was unsuccessfully or is disabled 1b: EEPROM autoload occurred successfully after PERST_L.	No	0
5	EEPROM is Autoload Disabled	RW	0b: EEPROM autoload is enabled 1b: EEPROM autoload is disabled	No/Yes	0

BIT	FUNCTION	TYPE	DESCRIPTION	EEPROM/ I2C-SMBUS	DEFAULT
7:6	EEPROM Clock Rate	RW	Determines the frequency of the EEPROM clock which is derived from the primary clock. 01b: PEXCLK/4 (PEXCLK is 250 MHz) Others: Reserved	No/Yes	01b
15:8	EEPROM Status	RO	Indicate the eeprom status.	No	00h
23:16	EEPROM Command	RW	01h: write STATUS register 02h: EEPROM write 03h: EEPROM read 04h: disable write operation 05h: read STATUS register 06h: enable write operation C7h: erase entire EEPROM	No/Yes	00h
30:24	Reserved	RsvdP	Not Support.	No	00h
31	Size 64K Mode	RW	0b: EEPROM size is less or equal to 64K 1b: EEPROM size is larger 64K	No/Yes	0

### 8.2.127 EEPROM ADDRESS AND DATA REGISTER – OFFSET 880h (Upstream Port Only)

BIT	FUNCTION	TYPE	DESCRIPTION	EEPROM/ I2C-SMBUS	DEFAULT
15:0	EEPROM Address	RW	Contains the EEPROM address.	No/Yes	0000h
31:16	EEPROM Data	RW	Contains the EEPROM data.	No/Yes	0000h

### 8.2.128 DEBUGOUT CONTROL REGISTER – OFFSET 884h (Upstream Port Only)

BIT	FUNCTION	TYPE	DESCRIPTION	EEPROM/ I2C-SMBUS	DEFAULT
4:0	Debug Mode Select	RW	Debug mode select.	No/Yes	0_0000b
7:5	Debug Port Select S1	RW	Debug port select s1.	No/Yes	000b
8	DebugPort Select S2	RW	Debugport select s2.	No/Yes	0
9	Debug Output Start	RW	Start to select debug output data.	No/Yes	0
31:10	Reserved	RsvdP	Not Support.	No	0-0h

### 8.2.129 DEBUGOUT DATA REGISTER – OFFSET 888h (Upstream Port Only)

BIT	FUNCTION	TYPE	DESCRIPTION	EEPROM/ I2C-SMBUS	DEFAULT
31:0	Debug Output Data	RO	Contains the debug output data.	No	0000_0000h

### 8.2.130 LTSSM\_CSR REGISTER – OFFSET 88Ch (Downstream Port Only)

BIT	FUNCTION	TYPE	DESCRIPTION	EEPROM/ I2C-SMBUS	DEFAULT
7:0	LTSSM_CSR	RW	Bit[2]: Pseudo MRL_PDC_En 0b: disable pseudo MRL_PDC function 1b: enable pseudo MRL_PDC function	Yes	00h
31:8	Reserved	RsvdP	Not Support.	No	0000_00h

### 8.2.131 MAC\_CSR REGISTER – OFFSET 890h

BIT	FUNCTION	TYPE	DESCRIPTION	EEPROM/ I2C-SMBUS	DEFAULT
15:0	Reserved	RsvdP	Not Support.	No	0000h
31:16	MAC_CSR	RW	MAC CSR value.	Yes	0004h

### 8.2.132 POWER SAVING DISABLE REGISTER – OFFSET 8A4h

BIT	FUNCTION	TYPE	DESCRIPTION	EEPROM/ I2C-SMBUS	DEFAULT
0	Power Saving Disable	RW	Disable power saving. 0b: enable power saving 1b: disable power saving	Yes	0
31:1	Reserved	RsvdP	Not Support.	No	0-0h

### 8.2.133 TRANSACTION LAYER CSR REGISTER – OFFSET 8A8h

BIT	FUNCTION	TYPE	DESCRIPTION	EEPROM/ I2C-SMBUS	DEFAULT
0	Egress_Reqcredit_Starve	RW	Test used only.	Yes	1
1	MF_Credit_Update_Dis	RW	Test used only.	Yes	0
2	MC_Cap_Dis	RW	Test used only.	Yes	0
3	MEM_Sharing_Dis	RO	Test used only.	Yes	0
31:4	Reserved	RsvdP	Not Support.	No	0-0h

### 8.2.134 REPLAY TIME-OUT COUNTER REGISTER – OFFSET 8ACh

BIT	FUNCTION	TYPE	DESCRIPTION	EEPROM/ I2C-SMBUS	DEFAULT
11:0	User Replay Timer	RW	A 12-bit register contains a user-defined value.	Yes	000h
12	Enable User Replay Timer	RW	When asserted, the user-defined replay time-out value is be employed. 0b: use the default replay time-out value 1b: use the user-defined replay time-out value on bit[11:0]	Yes	0
15:13	Reserved	RsvdP	Not Support.	No	000b

### 8.2.135 ACKNOWLEDGE LATENCY TIMER REGISTER – OFFSET 8ACh

BIT	FUNCTION	TYPE	DESCRIPTION	EEPROM/ I2C-SMBUS	DEFAULT
29:16	User ACK Latency Timer	RW	A 14-bit register contains a user-defined value.	Yes	0-0h
30	Enable User ACK Latency	RW	When asserted, the user-defined ACK latency value is be employed. 0b: use the default ack latency value 1b: use the user-defined ack latency value on bit[29:16]	Yes	0
31	Reserved	RsvdP	Not Support.	No	0

### 8.2.136 PORT MISC 0 REGISTER – OFFSET 8B0h

BIT	FUNCTION	TYPE	DESCRIPTION	EEPROM/ I2C-SMBUS	DEFAULT
7:0	Reserved	RsvdP	Not Support.	No	00h
13:8	Power Management Control Parameter	RW	Power Management Control parameter.	Yes	00_0001b
14	RX Polarity Inversion Disable	RW	0b: enable rx polarity inversion circuit 1b: disable rx polarity inversion circuit	Yes	0
15	Compliance Pattern Parity Control Disable	RW	0b: enable compliance pattern parity control 1b: disable compliance pattern parity control  It is set by Upstream Port Only.	Yes	0

### 8.2.137 PHY PARAMETER 0 REGISTER – OFFSET 8B0h (Upstream Port Only)

BIT	FUNCTION	TYPE	DESCRIPTION	EEPROM/ I2C-SMBUS	DEFAULT
20:16	C_DRV_LVL_3P5_NOM (Global)	RW	Set drive amplitude level. Please refer to Section 6.1.6 for more detail information.	Yes	1_0011b
25:21	C_DRV_LVL_6P0_NOM (Global)	RW	Set drive amplitude level. Please refer to Section 6.1.6 for more detail information.	Yes	10_011b
30:26	C_DRV_LVL_HALF_NOM (Global)	RW	Set drive amplitude level. Please refer to Section 6.1.6 for more detail information.	Yes	000_10b
31	Reserved	RsvdP	Not Support.	No	0

### 8.2.138 PORT MISC 1 REGISTER – OFFSET 8B4h

BIT	FUNCTION	TYPE	DESCRIPTION	EEPROM/ I2C-SMBUS	DEFAULT
7:0	Reserved	RsvdP	Not Support.	No	00h
9:8	DO_CHG_DATA_CNT_SEL	RW	The trying number for doing change data rate.	Yes	00b
10	Port Disable	RW	Disable this port.  0b: enable port 1b: disable port	Yes	0
11	Reset Select	RW	Reset select. It is valid for upstream port only.	Yes	1
15:12	Reserved	RsvdP	Not Support.	No	000b

### 8.2.139 XPIP\_CSR 6 REGISTER – OFFSET 8B4h

BIT	FUNCTION	TYPE	DESCRIPTION	EEPROM/ I2C-SMBUS	DEFAULT
23:16	XPIP_CSR6	RW	XPIP_CSR 6 value.	Yes	78h

### 8.2.140 XPIP\_CSR 7 REGISTER – OFFSET 8B4h

BIT	FUNCTION	TYPE	DESCRIPTION	EEPROM/ I2C-SMBUS	DEFAULT
25:24	REV_TS_CTR	RW	Test used only.	Yes	00
29:26	MAC Control Parameter	RW	Test used only.	Yes	0h
30	Line Loopback	RW	Test used only.	Yes	0

BIT	FUNCTION	TYPE	DESCRIPTION	EEPROM/ I2C-SMBUS	DEFAULT
31	P35_GEN2_MODE (Global)	RW	Test used only.	Yes	0

### 8.2.141 PORT MISC 2 REGISTER – OFFSET 8B8h

BIT	FUNCTION	TYPE	DESCRIPTION	EEPROM/ I2C-SMBUS	DEFAULT
0	Change_Role_En	RW	Test used only.	Yes	0
1	IPCore_Role	RW	Test used only.	Yes	0
31:2	Reserved	RsvdP	Not Support.	No	0-0h

### 8.2.142 LED DISPLAY CSR REGISTER – OFFSET 8BCh (Global)

BIT	FUNCTION	TYPE	DESCRIPTION	EEPROM/ I2C-SMBUS	DEFAULT
5:0	LED Display Mode Select	RW	Test used only.	Yes	00_0000b
7:6	Reserved	RsvdP	Not Support.	No	00b
13:8	Hotplug_Misc	RW	Bit[11:8] are used to control reset pulse for HotPlug function. Bit[8]: enable Bit[9]: issue reset pulse three times Bit[11:10]: control the width of the reset pulse 00b: 128 ms 01b: 256 ms 10b: 1 sec 11b: 2 sec Bit[12]: Reserved Bit[13]: enable the synchronize between IOE Interrupt and Hot- Plug state machine	Yes	0h
31:14	Reserved	RsvdP	Not Support.	No	0-0h

### 8.2.143 MULTI-CAST ENHANCED CAPABILITY HEADER REGISTER – OFFSET 900h

BIT	FUNCTION	TYPE	DESCRIPTION	EEPROM/ I2C-SMBUS	DEFAULT
15:0	Extended Capabilities ID	RO	Read as 0012h to indicate that these are PCI express extended capability registers for multi-cast capability.	No	0012h
19:16	Capability Version	RO	Read as 1h.	No	1h
31:20	Next Capability Offset	RO	Pointer points to 000h.	Yes	000h

### 8.2.144 MULTI-CAST CAPABILITY REGISTER – OFFSET 904h

BIT	FUNCTION	TYPE	DESCRIPTION	EEPROM/ I2C-SMBUS	DEFAULT
5:0	MC_Max_Group	RO	Value indicates the max. number of Multicast Groups that the component supports.	No	00_0001b
14:6	Reserved	RO	Not Support.	No	0
15	MC_ECRC_ Regeneration_ Supported	RO	If set, indicates that ECRC regeneration is supported.	No	0

### 8.2.145 MULTI-CAST CONTROL REGISTER – OFFSET 904h

BIT	FUNCTION	TYPE	DESCRIPTION	EEPROM/ I2C-SMBUS	DEFAULT
16	MC_Num_Group	RW	Value indicates the number of Multicast Groups configured for use.	No/Yes	00h
30:17	Reserved	RsvdP	Not Support.	No	0-0h
31	MC_ECRC_Regeneration_Supported	RW	When set, the Multicast mechanism is enabled for the component.	No/Yes	0

### 8.2.146 MULTI-CAST BASE ADDRESS 0 REGISTER – OFFSET 908h

BIT	FUNCTION	TYPE	DESCRIPTION	EEPROM/ I2C-SMBUS	DEFAULT
5:0	MC_Index_Position	RW	The location of the LSB of the Multicast Group number within the address.	No/Yes	00h
11:6	Reserved	RsvdP	Not Support.	No	00h
31:12	MC_Base_Address [31:12]	RW	The base address of the Multicast address range.	No/Yes	0-0h

### 8.2.147 MULTI-CAST BASE ADDRESS 1 REGISTER – OFFSET 90Ch

BIT	FUNCTION	TYPE	DESCRIPTION	EEPROM/ I2C-SMBUS	DEFAULT
31:0	MC_Base_Address [63:32]	RW	The base address of the Multicast address range.	No/Yes	0000-0000h

### 8.2.148 MULTI-CAST RECEIVER REGISTER – OFFSET 910h

BIT	FUNCTION	TYPE	DESCRIPTION	EEPROM/ I2C-SMBUS	DEFAULT
1:0	MC_Receive	RW	For each bit that's Set, this Function gets a copy of any Multicast TLPs for the associated Multicast Group.	No/Yes	00
31:2	Reserved	RsvdP	Not Support.	No	0-0h

### 8.2.149 MULTI-CAST BLOCK ALL REGISTER – OFFSET 918h

BIT	FUNCTION	TYPE	DESCRIPTION	EEPROM/ I2C-SMBUS	DEFAULT
1:0	MC_Block_All	RW	For each bit that is Set, this Function is blocked from sending TLPs to the associated Multicast Group.	No/Yes	00
31:2	Reserved	RsvdP	Not Support.	No	0-0h

### 8.2.150 MULTI-CAST BLOCK UNTRANSLATED REGISTER – OFFSET 920h

BIT	FUNCTION	TYPE	DESCRIPTION	EEPROM/ I2C-SMBUS	DEFAULT
1:0	MC_Block_Untranslated	RW	For each bit that is Set, this Function is blocked from sending TLPs containing Untranslated Addresses to the associated MCG.	No/Yes	00
31:2	Reserved	RsvdP	Not Support.	No	0-0h

### 8.2.151 EEPROM\_SCRATCHPAD REGISTER - OFFSET FB0h

BIT	FUNCTION	TYPE	DESCRIPTION	EEPROM/ I2C-SMBUS	DEFAULT
31:0	EEPROM_Scratchpad	RO	Test used only.	Yes	0000_0000h

### 8.2.152 PCI EXPRESS ADVANCED ERROR REPORTING ENHANCED CAPABILITY HEADER REGISTER – OFFSET FB4h

BIT	FUNCTION	TYPE	DESCRIPTION	EEPROM/ I2C-SMBUS	DEFAULT
15:0	Extended Capabilities ID	RO	Read as 0001h to indicate that these are PCI express extended capability registers for advance error reporting.	No	0001h
19:16	Capability Version	RO	Read as 1h.	No	1h
31:20	Next Capability Offset	RO	Pointer points to the Power Budgeting Extended Capability structure for upstream port / the Port VC Extended Capability structure for downstream ports.	Yes	138h for Up 148h for Down

### 8.2.153 UNCORRECTABLE ERROR STATUS REGISTER – OFFSET FB8h

BIT	FUNCTION	TYPE	DESCRIPTION	EEPROM/ I2C-SMBUS	DEFAULT
0	Training Error Status	RW1C	When set, indicates that the Training Error event has occurred.	No/Yes	0
3:1	Reserved	RsvdP	Not Support.	No	000
4	Data Link Protocol Error Status	RW1C	When set, indicates that the Data Link Protocol Error event has occurred.	No/Yes	0
11:5	Reserved	RsvdP	Not Support.	No	0-0b
12	Poisoned TLP Status	RW1C	When set, indicates that a Poisoned TLP has been received or generated.	No/Yes	0
13	Flow Control Protocol Error Status	RW1C	When set, indicates that the Flow Control Protocol Error event has occurred.	No/Yes	0
14	Completion Timeout Status	RW1C	When set, indicates that the Completion Timeout event has occurred.	No/Yes	0
15	Completer Abort Status	RW1C	When set, indicates that the Completer Abort event has occurred.	No/Yes	0
16	Unexpected Completion Status	RW1C	When set, indicates that the Unexpected Completion event has occurred.	No/Yes	0
17	Receiver Overflow Status	RW1C	When set, indicates that the Receiver Overflow event has occurred.	No/Yes	0
18	Malformed TLP Status	RW1C	When set, indicates that a Malformed TLP has been received.	No/Yes	0
19	ECRC Error Status	RW1C	When set, indicates that an ECRC Error has been detected.	No/Yes	0
20	Unsupported Request Error Status	RW1C	When set, indicates that an Unsupported Request event has occurred.	No/Yes	0
21	ACS Violation Status	RW1C	When set, indicates that an ACS Violation event has occurred.	No/Yes	0
22	Reserved	RsvdP	Not Support.	No	0
23	MC Blocked TLP Status	RW1C	When set, indicates that an MC Blocked TLP event has occurred.	No/Yes	0
31:24	Reserved	RsvdP	Not Support.	No	00h

### 8.2.154 UNCORRECTABLE ERROR MASK REGISTER – OFFSET FBCh

BIT	FUNCTION	TYPE	DESCRIPTION	EEPROM/ I2C-SMBUS	DEFAULT
0	Training Error Mask	RW	When set, the Training Error event is not logged in the Header Log register and not issued as an Error Message to RC either.	No/Yes	0
3:1	Reserved	RsvdP	Not Support.	No	000b
4	Data Link Protocol Error Mask	RW	When set, the Data Link Protocol Error event is not logged in the Header Log register and not issued as an Error Message to RC either.	No/Yes	0
11:5	Reserved	RsvdP	Not Support.	No	0-0b
12	Poisoned TLP Mask	RW	When set, an event of Poisoned TLP is not logged in the Header Log register and not issued as an Error Message to RC either.	No/Yes	0
13	Flow Control Protocol Error Mask	RW	When set, the Flow Control Protocol Error event is not logged in the Header Log register and not issued as an Error Message to RC either.	No/Yes	0
14	Completion Timeout Mask	RW	When set, the Completion Timeout event is not logged in the Header Log register and not issued as an Error Message to RC either.	No/Yes	0
15	Completer Abort Mask	RW	When set, the Completer Abort event is not logged in the Header Log register and not issued as an Error Message to RC either.	No/Yes	0
16	Unexpected Completion Mask	RW	When set, the Unexpected Completion event is not logged in the Header Log register and not issued as an Error Message to RC either.	No/Yes	0
17	Receiver Overflow Mask	RW	When set, the Receiver Overflow event is not logged in the Header Log register and not issued as an Error Message to RC either.	No/Yes	0
18	Malformed TLP Mask	RW	When set, an event of Malformed TLP is not logged in the Header Log register and not issued as an Error Message to RC either.	No/Yes	0
19	ECRC Error Mask	RW	When set, an event of ECRC Error is not logged in the Header Log register and not issued as an Error Message to RC either.	No/Yes	0
20	Unsupported Request Error Mask	RW	When set, the Unsupported Request event is not logged in the Header Log register and not issued as an Error Message to RC either.	No/Yes	0
21	ACS Violation Mask	RW	When set, the ACS Violation event is not logged in the Header Log register and not issued as an Error Message to RC either.	No/Yes	0
22	Reserved	RsvdP	Not Support.	No	0
23	MC Blocked TLP Mask	RW	When set, the MC Blocked TLP event is not logged in the Header Log register and not issued as an Error Message to RC either.	No/Yes	0
31:24	Reserved	RsvdP	Not Support.	No	00h

### 8.2.155 UNCORRECTABLE ERROR SEVERITY REGISTER – OFFSET FC0h

BIT	FUNCTION	TYPE	DESCRIPTION	EEPROM/ I2C-SMBUS	DEFAULT
0	Training Error Severity	RW	0b: Non-Fatal 1b: Fatal	No/Yes	1
3:1	Reserved	RsvdP	Not Support.	No	000b
4	Data Link Protocol Error Severity	RW	0b: Non-Fatal 1b: Fatal	No/Yes	1
11:5	Reserved	RsvdP	Not Support.	No	0-0b
12	Poisoned TLP Severity	RW	0b: Non-Fatal 1b: Fatal	No/Yes	0
13	Flow Control Protocol Error Severity	RW	0b: Non-Fatal 1b: Fatal	No/Yes	1
14	Completion Timeout Error Severity	RW	0b: Non-Fatal 1b: Fatal	No/Yes	0
15	Completer Abort Severity	RW	0b: Non-Fatal 1b: Fatal	No/Yes	0
16	Unexpected Completion Severity	RW	0b: Non-Fatal 1b: Fatal	No/Yes	0



BIT	FUNCTION	TYPE	DESCRIPTION	EEPROM/ I2C-SMBUS	DEFAULT
17	Receiver Overflow Severity	RW	0b: Non-Fatal 1b: Fatal	No/Yes	1
18	Malformed TLP Severity	RW	0b: Non-Fatal 1b: Fatal	No/Yes	1
19	ECRC Error Severity	RW	0b: Non-Fatal 1b: Fatal	No/Yes	0
20	Unsupported Request Error Severity	RW	0b: Non-Fatal 1b: Fatal	No/Yes	0
21	ACS Violation Severity	RW	0b: Non-Fatal 1b: Fatal	No/Yes	0
22	Reserved	RsvdP	Not Support.	No	0
23	MC Blocked TLP Severity	RW	0b: Not-Fatal 1b: Fatal	No/Yes	0
31:24	Reserved	RsvdP	Not Support.	No	00h

### 8.2.156 CORRECTABLE ERROR STATUS REGISTER – OFFSET FC4h

BIT	FUNCTION	TYPE	DESCRIPTION	EEPROM/ I2C-SMBUS	DEFAULT
0	Receiver Error Status	RW1C	When set, the Receiver Error event is detected.	No/Yes	0
5:1	Reserved	RsvdP	Not Support.	No	0 000b
6	Bad TLP Status	RW1C	When set, the event of Bad TLP has been received is detected.	No/Yes	0
7	Bad DLLP Status	RW1C	When set, the event of Bad DLLP has been received is detected.	No/Yes	0
8	REPLAY_NUM Rollover status	RW1C	When set, the REPLAY_NUM Rollover event is detected.	No/Yes	0
11:9	Reserved	RsvdP	Not Support.	No	000b
12	Replay Timer Timeout status	RW1C	When set, the Replay Timer Timeout event is detected.	No/Yes	0
13	Advisory Non-Fatal Error status	RW1C	When set, the Advisory Non-Fatal Error event is detected.	No/Yes	0
31:14	Reserved	RsvdP	Not Support.	No	0-0h

### 8.2.157 CORRECTABLE ERROR MASK REGISTER – OFFSET FC8h

BIT	FUNCTION	TYPE	DESCRIPTION	EEPROM/ I2C-SMBUS	DEFAULT
0	Receiver Error Mask	RW	When set, the Receiver Error event is not logged in the Header Log register and not issued as an Error Message to RC either.	No/Yes	0
5:1	Reserved	RsvdP	Not Support.	No	0 000b
6	Bad TLP Mask	RW	When set, the event of Bad TLP has been received is not logged in the Header Log register and not issued as an Error Message to RC either.	No/Yes	0
7	Bad DLLP Mask	RW	When set, the event of Bad DLLP has been received is not logged in the Header Log register and not issued as an Error Message to RC either.	No/Yes	0
8	REPLAY_NUM Rollover Mask	RW	When set, the REPLAY_NUM Rollover event is not logged in the Header Log register and not issued as an Error Message to RC either.	No/Yes	0
11:9	Reserved	RsvdP	Not Support.	No	000b
12	Replay Timer Timeout Mask	RW	When set, the Replay Timer Timeout event is not logged in the Header Log register and not issued as an Error Message to RC either.	No/Yes	0
13	Advisory Non-Fatal Error Mask	RW	When set, the Advisory Non-Fatal Error event is not logged in the Header Long register and not issued as an Error Message to RC either.	No/Yes	1
31:14	Reserved	RsvdP	Not Support.	No	0-0h

### 8.2.158 ADVANCE ERROR CAPABILITIES AND CONTROL REGISTER – OFFSET FCCh

BIT	FUNCTION	TYPE	DESCRIPTION	EEPROM/ I2C-SMBUS	DEFAULT
4:0	First Error Pointer	RO	It indicates the bit position of the first error reported in the Uncorrectable Error Status register.	No	0_0000b
5	ECRC Generation Capable	RO	When set, it indicates the Switch has the capability to generate ECRC.	No	1
6	ECRC Generation Enable	RW	When set, it enables the generation of ECRC when needed.	No/Yes	0
7	ECRC Check Capable	RO	When set, it indicates the Switch has the capability to check ECRC.	No	1
8	ECRC Check Enable	RW	When set, the function of checking ECRC is enabled..	No/Yes	0
31:9	Reserved	RsvdP	Not Support.	No	0-0h

### 8.2.159 HEADER LOG REGISTER – OFFSET From FD0h to FDCh

BIT	FUNCTION	TYPE	DESCRIPTION	EEPROM/ I2C-SMBUS	DEFAULT
31:0	1 <sup>st</sup> DWORD	RO	Hold the 1st DWORD of TLP Header. The Head byte is in big endian.	No	0000_0000h
63:32	2 <sup>nd</sup> DWORD	RO	Hold the 2nd DWORD of TLP Header. The Head byte is in big endian.	No	0000_0000h
95:64	3 <sup>rd</sup> DWORD	RO	Hold the 3rd DWORD of TLP Header. The Head byte is in big endian.	No	0000_0000h
127:96	4 <sup>th</sup> DWORD	RO	Hold the 4th DWORD of TLP Header. The Head byte is in big endian.	No	0000_0000h

### 8.3 NON TRANSPARENT PORT LINK INTERFACE CONFIGURATION REGISTERS – NT Mode Only

When the port of the Switch is set to operate at the non-transparent mode, it is represented by an Other Bridge that implements type 0 configuration space header. The following table details the allocation of the register fields of the PCI 2.3 compatible type 0 configuration space header.

31 – 24	23 – 16	15 – 8	7 – 0	BYTE OFFSET
Device ID		Vendor ID		00h
Primary Status		Command		04h
Class Code		Revision ID		08h
Reserved	Header Type	Reserved	Cache Line Size	0Ch
BAR 0				10h
BAR 1				14h
BAR 2				18h
BAR 3				1Ch
BAR 4				20h
BAR 5				24h
Reserved				28h
SSID		SSVID		2Ch
Reserved		Reserved		30h
Reserved		Capability Pointer to 40h		34h
Reserved				38h
Reserved		Interrupt Pin	Interrupt Line	3Ch
Power Management Capabilities		Next Item Pointer=48h	Capability ID=01h	40h
PM Data	PPB Support Extensions	Power Management Data		44h
Message Control		Next Item Pointer=68h	Capability ID=05h	48h
Message Address				4Ch
Message Upper Address				50h
Reserved		Message Data		54h
Reserved				58h – 64h
PCI Express Capabilities Register		Next Item Pointer=A4h	Capability ID=10h	68h
Device Capabilities				6Ch
Device Status		Device Control		70h
Link Capabilities				74h
Link Status		Link Control		78h
Reserved				7Ch - 90h
Link Capabilities 2				94h
Link Status 2		Link Control 2		98h
Reserved				9Ch – A0h
Reserved		Next Item Pointer=C8h	SSID/SSVID Capability ID=0Dh	A4h
SSID		SSVID		A8h
Reserved				ACh – C4h
Length		Next Item Pointer=00h	Vendor Specific Capability ID=09h	C8h
Vendor Specific Header Register				CCh
Reserved				D0h – E0h
NT Port Link Interface BAR 0-1 Configuration				E4h
NT Port Link Interface BAR 2 Configuration				E8h
NT Port Link Interface BAR 2-3 Configuration				ECh
NT Port Link Interface BAR 4 Configuration				F0h
NT Port Link Interface BAR 4-5 Configuration				F4h
Reserved				F8h - FCh

Other than the PCI 2.3 compatible configuration space header, the Switch also implements PCI express extended configuration space header, which includes advanced error reporting, virtual channel, and power budgeting capability registers. The following table details the allocation of the register fields of PCI express extended capability space header. The first extended capability always begins at offset 100h with a PCI Express Enhanced

Capability header and the rest of capabilities are located at an offset greater than 0FFh relative to the beginning of PCI compatible configuration space.

31 – 24	23 – 16	15 – 8	7 – 0	BYTE OFFSET
Next Capability Offset=FB4h	Cap. Version	PCI Express Extended Capability ID=0003h		100h
Serial Number Lower DW				104h
Serial Number Upper DW				108h
Reserved				10Ch – 134h
Next Capability Offset=148h	Cap. Version	PCI Express Extended Capability ID=0004h		138h
Reserved			Data Select Register	13Ch
Data Register				140h
Reserved			Power Budget Capability Register	144h
Next Capability Offset=000h	Cap. Version	PCI Express Extended Capability ID=0002h		148h
Port VC Capability Register 1				14Ch
VC Arbitration Table Offset=4h	Port VC Capability Register 2			150h
Port VC Status		Port VC Control		154h
Port Arbitration Table Offset=5h	VC Resource Capability Register (0)			158h
VC Resource Control Register (0)				15Ch
VC Resource Status Register (0)		Reserved		160h
Port Arbitration Table Offset=6h	VC Resource Capability Register (1)			164h
VC Resource Control Register (1)				168h
VC Resource Status Register (1)		Reserved		16Ch
Reserved				170h – 184h
VC Arbitration Table 0				188h
VC Arbitration Table 1				18Ch
VC Arbitration Table 2				190h
VC Arbitration Table 3				194h
Port VC0 Arbitration Table 0 (Low)				198h
Port VC0 Arbitration Table 0 (Upper)				19Ch
Port VC0 Arbitration Table 1 (Low)				1A0h
Port VC0 Arbitration Table 1 (Upper)				1A4h
Port VC1 Arbitration Table 0 (Low)				1A8h
Port VC1 Arbitration Table 0 (Upper)				1ACh
Port VC1 Arbitration Table 1 (Low)				1B0h
Port VC1 Arbitration Table 1 (Upper)				1B4h
Reserved				1B8h – 840h
XPIP_CSR 0				844h
XPIP_CSR 1				848h
Decode VGA	Reserved		Reserved	84Ch
Reserved				850h
Reserved		XPIP_CSR 2		854h
PHY Parameter 2				858h
PHY Parameter 3				85Ch
Reserved				860h
XPIP_CSR 3				864h
Reserved				868h
XPIP_CSR 5				86Ch
Reserved				870h
Operation Mode				874h
Reserved				878h – 88Ch
MAC_CSR 1				890h
Reserved				894h – 8A0h
Power Saving Disable				8A4h
Transaction Layer_CSR				8A8h
ACK Latency Timer		Replay Time-out Counter		8ACh
Reserved		Port Misc 0		8B0h
XPIP_CSR 7	XPIP_CSR 6	Port Misc 1		8B4h

31 – 24	23 – 16	15 - 8	7 – 0	BYTE OFFSET
Reserved		Port Misc 2		8B8h
Reserved				8BCh – C30h
Next Capability Offset=000h	Cap. Version	PCI Express Extended Capability ID=000Bh		C34h
Vendor Specific Header				C38h
Translation BAR 2				C3Ch
Translation BAR 3				C40h
Translation BAR 4				C44h
Translation BAR 5				C48h
Reserved	Virtual IF IRQ Set			C4Ch
Reserved	Virtual IF IRQ Clear			C50h
Reserved	Virtual IF IRQ Mask Set			C54h
Reserved	Virtual IF IRQ Mask Clear			C58h
Reserved	Link IF IRQ Set			C5Ch
Reserved	Link IF IRQ Clear			C60h
Reserved	Link IF IRQ Mask Set			C64h
Reserved	Link IF IRQ Mask Clear			C68h
Scratchpad 0				C6Ch
Scratchpad 1				C70h
Scratchpad 2				C74h
Scratchpad 3				C78h
Scratchpad 4				C7Ch
Scratchpad 5				C80h
Scratchpad 6				C84h
Scratchpad 7				C88h
Reserved				C8Ch – D90h
Virtual Port 32-Bits LTT Entry 0				D94h
Virtual Port 32-Bits LTT Entry 1				D98h
Virtual Port 32-Bits LTT Entry 2				D9Ch
Virtual Port 32-Bits LTT Entry 3				DA0h
Virtual Port 32-Bits LTT Entry 4				DA4h
Virtual Port 32-Bits LTT Entry 5				DA8h
Virtual Port 32-Bits LTT Entry 6				DACH
Virtual Port 32-Bits LTT Entry 7				DB0h
Link Port 16-Bits LTT Entry 0-1				DB4h
Link Port 16-Bits LTT Entry 2-3				DB8h
Link Port 16-Bits LTT Entry 4-5				DBCh
Link Port 16-Bits LTT Entry 6-7				DC0h
Link Port 16-Bits LTT Entry 8-9				DC4h
Link Port 16-Bits LTT Entry 10-11				DC8h
Link Port 16-Bits LTT Entry 12-13				DCCh
Link Port 16-Bits LTT Entry 14-15				DD0h
Link Port 16-Bits LTT Entry 16-17				DD4h
Link Port 16-Bits LTT Entry 18-19				DD8h
Link Port 16-Bits LTT Entry 20-21				DDCh
Link Port 16-Bits LTT Entry 22-23				DE0h
Link Port 16-Bits LTT Entry 24-25				DE4h
Link Port 16-Bits LTT Entry 26-27				DE8h
Link Port 16-Bits LTT Entry 28-29				DECh
Link Port 16-Bits LTT Entry 30-31				DF0h
Fail-Over CSR				DF4h
Reserved				DF8h – FACH
EEPROM Scratchpad				FB0h
Next Capability Offset=138h	Cap. Version	PCI Express Extended Capability ID=0001h		FB4h
Uncorrectable Error Status Register				FB8h
Uncorrectable Error Mask Register				FBCh
Uncorrectable Error Severity Register				FC0h
Correctable Error Status Register				FC4h
Correctable Error Mask Register				FC8h
Advanced Error Capabilities and Control Register				FCh
Header Log Register 0				FD0h
Header Log Register 1				FD4h
Header Log Register 2				FD8h

31 – 24	23 – 16	15 - 8	7 – 0	BYTE OFFSET
Header Log Register 3				FDCh
Reserved				FE0h – FFCh

### 8.3.1 VENDOR ID REGISTER – OFFSET 00h

BIT	FUNCTION	TYPE	DESCRIPTION	EEPROM/ I2C-SMBUS	DEFAULT
15:0	Vendor ID	RO	Identifies Pericom as the vendor of this device.	Yes	12D8h

### 8.3.2 DEVICE ID REGISTER – OFFSET 00h

BIT	FUNCTION	TYPE	DESCRIPTION	EEPROM/ I2C-SMBUS	DEFAULT
31:16	Device ID	RO	Identifies this device as the PI7C9X2G808PR.	Yes	8608h

### 8.3.3 COMMAND REGISTER – OFFSET 04h

BIT	FUNCTION	TYPE	DESCRIPTION	EEPROM/ I2C-SMBUS	DEFAULT
0	I/O Space Enable	RW	0b: Ignores I/O transactions on the primary interface 1b: Enables responses to I/O transactions on the primary interface	No/Yes	0
1	Memory Space Enable	RW	0b: Ignores memory transactions on the primary interface 1b: Enables responses to memory transactions on the primary interface	No/Yes	0
2	Bus Master Enable	RW	0b: Does not initiate memory or I/O transactions on the upstream port and handles as an Unsupported Request (UR) to memory and I/O transactions on the downstream port. For Non-Posted Requests, a completion with UR completion status must be returned 1b: Enables the Switch Port to forward memory and I/O Read/Write transactions in the upstream direction	No/Yes	0
3	Special Cycle Enable	RsvdP	Not Support.	No	0
4	Memory Write And Invalidate Enable	RsvdP	Not Support.	No	0
5	VGA Palette Snoop Enable	RsvdP	Not Support.	No	0
6	Parity Error Response Enable	RW	0b: Switch may ignore any parity errors that it detects and continue normal operation 1b: Switch must take its normal action when a parity error is detected	No/Yes	0
7	Wait Cycle Control	RsvdP	Not Support.	No	0
8	SERR# enable	RW	0b: Disables the reporting of Non-fatal and Fatal errors detected by the Switch to the Root Complex 1b: Enables the Non-fatal and Fatal error reporting to Root Complex	No/Yes	0
9	Fast Back-to-Back Enable	RsvdP	Not Support.	No	0
10	Interrupt Disable	RW	0b: Enable to generate INTx Interrupt Messages 1b: Disable to generate INTx Interrupt Messages	No/Yes	0
15:11	Reserved	RsvdP	Reset to 5'b0.	No	0000_0b

### 8.3.4 PRIMARY STATUS REGISTER – OFFSET 04h

BIT	FUNCTION	TYPE	DESCRIPTION	EEPROM/ I2C-SMBUS	DEFAULT
18:16	Reserved	RsvdP	Not Support.	No	00b
19	Interrupt Status	RO	Indicates that an INTx Interrupt Message is pending internally to the device. In the Switch, the forwarding of INTx messages from the downstream device of the Switch port is not reflected in this bit. Must be hardwired to 1'b0.	No	0
20	Capabilities List	RO	Set to 1b to enable support for the capability list (offset 34h is the pointer to the data structure).	No	1
21	66MHz Capable	RsvdP	Not Support.	No	0
22	Reserved	RsvdP	Not Support.	No	0
23	Fast Back-to-Back Capable	RsvdP	Not Support.	No	0
24	Master Data Parity Error	RW1C	Set to 1b (by a requester) whenever a Parity error is detected or forwarded on the primary side of the port in a Switch.  If the Parity Error Response Enable bit is cleared, this bit is never set.	No/Yes	
26:25	DEVSEL# timing	RsvdP	Not Support.	No	00b
27	Signaled Target Abort	RsvdP	Not Support.	No	0
28	Received Target Abort	RsvdP	Not Support.	No	0
29	Received Master Abort	RsvdP	Not Support.	No	0
30	Signaled System Error	RW1C	Set to 1b when the Switch sends an ERR_FATAL or ERR_NONFATAL Message, and the SERR Enable bit in the Command register is 1.	No/Yes	0
31	Detected Parity Error	RW1C	Set to 1b whenever the primary side of the port in a Switch receives a Poisoned TLP.	No/Yes	0

### 8.3.5 REVISION ID REGISTER – OFFSET 08h

BIT	FUNCTION	TYPE	DESCRIPTION	EEPROM/ I2C-SMBUS	DEFAULT
7:0	Revision	RO	Indicates revision number of device.	No/Yes	00h

### 8.3.6 CLASS CODE REGISTER – OFFSET 08h

BIT	FUNCTION	TYPE	DESCRIPTION	EEPROM/ I2C-SMBUS	DEFAULT
15:8	Programming Interface	RO	Read as 00h to indicate no programming interfaces have been defined for PCI-to-PCI Bridges.	No	00h
23:16	Sub-Class Code	RO	Read as 80h to indicate device is an Other Bridge.	No	80h
31:24	Base Class Code	RO	Read as 06h to indicate device is a Bridge device.	No	06h

### 8.3.7 CACHE LINE REGISTER – OFFSET 0Ch

BIT	FUNCTION	TYPE	DESCRIPTION	EEPROM/ I2C-SMBUS	DEFAULT
7:0	Cache Line Size	RW	The cache line size register is set by the system firmware and the operating system cache line size. This field is implemented by PCI Express devices as a RW field for legacy compatibility, but it has no impact on any PCI Express device functionality.	No/Yes	00h

### 8.3.8 PRIMARY LATENCY TIMER REGISTER – OFFSET 0Ch

BIT	FUNCTION	TYPE	DESCRIPTION	EEPROM/ I2C-SMBUS	DEFAULT
15:8	Primary Latency Timer	RsvdP	Not Support.	No	00h

### 8.3.9 HEADER TYPE REGISTER – OFFSET 0Ch

BIT	FUNCTION	TYPE	DESCRIPTION	EEPROM/ I2C-SMBUS	DEFAULT
23:16	Header Type	RO	Read as 00h to indicate that the register layout conforms to Type 0 Configuration Header for the NT Port.	No	00h

### 8.3.10 BAR 0 REGISTER – OFFSET 10h

BIT	FUNCTION	TYPE	DESCRIPTION	EEPROM/ I2C-SMBUS	DEFAULT
0	Memory Space Indicator	RO	Reset to 0b to indicate the Base Address register maps NT Port Configuration registers into Memory Space.	No	0
2:1	Memory Map Type	RO	00b: support 32-bit Memory Space. 10b: support 64-bit Memory Space.	No	00b
3	Prefetchable	RO	Reset to 0b to indicate NT Port Configuration registers maps to Non-Prefetchable Memory Space.	No	0
16:4	Reserved	RsvdP	Not Support.	No	0-0h
31:17	Base Address 0	RW	Use this Memory base address to map the NT-Port Configuration registers.	No/Yes	0-0h

### 8.3.11 BAR 1 REGISTER – OFFSET 14h

BIT	FUNCTION	TYPE	DESCRIPTION	EEPROM/ I2C-SMBUS	DEFAULT
31:0	Base Address 1	RW	RO when the Base Address 0 register is not 64-bit addressing (offset 10h[2:1] is not 10b). RW when the Base Address 0 register is 64-bit addressing. Base Address 1 is used to provide the upper 32 Address bits when offset 10h[2:1] is set to 10b.	No/Yes	0000_0000h

### 8.3.12 BAR 2 REGISTER – OFFSET 18h

BIT	FUNCTION	TYPE	DESCRIPTION	EEPROM/ I2C-SMBUS	DEFAULT
0	Memory Space Indicator	RO	Reset to 0b to indicate it is a Memory BAR.	No	0
2:1	Memory Map Type	RO	00b: support 32-bit Memory Space 10b: support 64-bit Memory Space	No	00b
3	Prefetchable	RO	Reset to 0b to indicate NT Port Configuration registers maps to Non-Prefetchable Memory Space.	No	0
19:4	Reserved	RsvdP	Not Support.	No	0-0h
31:20	Base Address 2	RW	Base Address 2.	No/Yes	000h



### 8.3.13 BAR 3 REGISTER – OFFSET 1Ch

BIT	FUNCTION	TYPE	DESCRIPTION	EEPROM/ I2C-SMBUS	DEFAULT
0	Memory Space Indicator	RO	When 18h[2:1]=00b, BAR 3 is used as an independent 32-bit BAR.	No	0
		RW	When 18h[2:1]=10b, BAR 3 is used as the upper 32 bits of 64-bit BAR 2/3.	No/Yes	0
2:1	Memory Map Type	RO	When 18h[2:1]=00b, BAR 3 is used as an independent 32-bit BAR.	No	00b
		RW	When 18h[2:1]=10b, BAR 3 is used as the upper 32 bits of 64-bit BAR 2/3.	No/Yes	00b
3	Prefetchable	RO	When 18h[2:1]=00b, BAR 3 is used as an independent 32-bit BAR.	No	0
		RW	When 18h[2:1]=10b, BAR 3 is used as the upper 32 bits of 64-bit BAR 2/3.	No/Yes	0
31:4	Base Address 3	RsvdP	When 18h[2:1]=00b, BAR 3 is used as an independent 32-bit BAR.	No	0000_000h
		RW	When 18h[2:1]=10b, BAR 3 is used as the upper 32 bits of 64-bit BAR 2/3.	No/Yes	0000_000h

### 8.3.14 BAR 4 REGISTER – OFFSET 20h

BIT	FUNCTION	TYPE	DESCRIPTION	EEPROM/ I2C-SMBUS	DEFAULT
0	Memory Space Indicator	RO	Reset to 0b to indicate it is a Memory BAR.	No	0
2:1	Memory Map Type	RO	00b: support 32-bit Memory Space 10b: support 64-bit Memory Space	No	00b
3	Prefetchable	RO	Reset to 0b to indicate NT Port Configuration registers maps to Non-Prefetchable Memory Space.	No	0
19:4	Reserved	RsvdP	Not Support.	No	0-0h
31:20	Base Address 4	RW	Base Address 4.	No/Yes	000h

### 8.3.15 BAR 5 REGISTER – OFFSET 24h

BIT	FUNCTION	TYPE	DESCRIPTION	EEPROM/ I2C-SMBUS	DEFAULT
0	Memory Space Indicator	RO	When 20h[2:1]=00b, BAR 5 is used as an independent 32-bit BAR.	No	0
		RW	When 20h[2:1]=10b, BAR 5 is used as the upper 32 bits of 64-bit BAR 4/5.	No/Yes	0
1	Memory Space Enable	RO	When 20h[2:1]=00b, BAR 5 is used as an independent 32-bit BAR.	No	00b
		RW	When 20h[2:1]=10b, BAR 5 is used as the upper 32 bits of 64-bit BAR 4/5.	No/Yes	00b
2:1	Memory Map Type	RO	When 20h[2:1]=00b, BAR 5 is used as an independent 32-bit BAR.	No	0
3	Prefetchable	RW	When 20h[2:1]=10b, BAR 5 is used as the upper 32 bits of 64-bit BAR 4/5.	No/Yes	0
31:4	Base Address 3	RsvdP	When 20h[2:1]=00b, BAR 5 is used as an independent 32-bit BAR.	No	0000_000h
		RW	When 20h[2:1]=10b, BAR 5 is used as the upper 32 bits of 64-bit BAR 4/5.	No/Yes	0000_000h

### 8.3.16 SUBSYSTEM VENDOR ID REGISTER – OFFSET 2Ch

BIT	FUNCTION	TYPE	DESCRIPTION	EEPROM/ I2C-SMBUS	DEFAULT
15:0	SSVID	RO	It indicates the sub-system vendor id.	No/Yes	12D8h

### 8.3.17 SUBSYSTEM ID REGISTER – OFFSET 2Ch

BIT	FUNCTION	TYPE	DESCRIPTION	EEPROM/ I2C-SMBUS	DEFAULT
31:16	SSID	RO	It indicates the sub-system device id.	No/Yes	8608h

### 8.3.18 CAPABILITY POINTER REGISTER – OFFSET 34h

BIT	FUNCTION	TYPE	DESCRIPTION	EEPROM/ I2C-SMBUS	DEFAULT
7:0	Capability Pointer	RO	Indicates next capability pointer.	Yes	40h

### 8.3.19 INTERRUPT LINE REGISTER – OFFSET 3Ch

BIT	FUNCTION	TYPE	DESCRIPTION	EEPROM/ I2C-SMBUS	DEFAULT
7:0	Interrupt Line	RW	Indicates Interrupt Line.	No/Yes	00h

### 8.3.20 INTERRUPT PIN REGISTER – OFFSET 3Ch

BIT	FUNCTION	TYPE	DESCRIPTION	EEPROM/ I2C-SMBUS	DEFAULT
15:8	Interrupt Pin	RO	The Switch implements INTA virtual wire interrupt signal. Only 00h or 01h is valid.	Yes	01h

### 8.3.21 POWER MANAGEMENT CAPABILITIES REGISTER – OFFSET 40h

BIT	FUNCTION	TYPE	DESCRIPTION	EEPROM/ I2C-SMBUS	DEFAULT
7:0	Enhanced Capabilities ID	RO	Read as 01h to indicate that these are power management enhanced capability registers.	No	01h
15:8	Next Item Pointer	RO	The pointer points to the MSI capability Structure.	Yes	48h
18:16	Power Management Revision	RO	Read as 011b to indicate the device is compliant to Revision 1.2 of <i>PCI Power Management Interface Specifications</i> .	No	011b
19	PME# Clock	RsvdP	Not Support.	No	0
20	Reserved	RsvdP	Not Support.	No	0
21	Device Specific Initialization	RO	Read as 0b to indicate Switch does not have device specific initialization requirements.	Yes	0
24:22	AUX Current	RO	Reset to 000b.	Yes	000b
25	D1 Power State Support	RO	Read as 0b to indicate Switch does not support the D1 power management state.	Yes	0
26	D2 Power State Support	RO	Read as 0b to indicate Switch does not support the D2 power management state.	Yes	0
31:27	PME# Support	RO	Read as 19h to indicate Switch supports the forwarding of PME# message in D0, D3 and D4 states.	Yes	19h

### 8.3.22 POWER MANAGEMENT DATA REGISTER – OFFSET 44h

BIT	FUNCTION	TYPE	DESCRIPTION	EEPROM/ I2C-SMBUS	DEFAULT
1:0	Power State	RW	Indicates the current power state of the Switch. Writing a value of D0 when the previous state was D3 cause a hot reset without asserting DWRST_L.  00b: D0 state 01b: D1 state 10b: D2 state 11b: D3 hot state	No/Yes	00b
2	Reserved	RsvdP	Not Support.	No	0
3	No_Soft_Reset	RO	When set, this bit indicates that device transitioning from D3hot to D0 does not perform an internal reset. When clear, an internal reset is performed when power state transits from D3hot to D0.	Yes	1
7:4	Reserved	RsvdP	Not Support.	No	0h
8	PME# Enable	RW	When asserted, the Switch will generate the PME# message.	No/Yes	0
12:9	Data Select	RW	Select data registers  RW if offset 870h[1]=1 and RO if offset 870h[1]=0.	No/Yes	0h
14:13	Data Scale	RO	Reset to 00b.	No	00b
15	PME Status	RO	Read as 0b as the PME# message is not implemented.	No	0

### 8.3.23 PPB SUPPORT EXTENSIONS – OFFSET 44h

BIT	FUNCTION	TYPE	DESCRIPTION	EEPROM/ I2C-SMBUS	DEFAULT
21:16	Reserved	RsvdP	Not Support.	No	00_0000b
22	B2_B3 Support for D3HOT	RO	Does not apply to PCI Express. Must be hardwired to 0.	No	0
23	Bus Power / Clock Control Enable	RO	Does not apply to PCI Express. Must be hardwired to 0.	No	0

### 8.3.24 DATA REGISTER – OFFSET 44h

BIT	FUNCTION	TYPE	DESCRIPTION	EEPROM/ I2C-SMBUS	DEFAULT
31:24	Data Register	RO	Data Register.	Yes	00h

### 8.3.25 MSI CAPABILITIES REGISTER – OFFSET 48h

BIT	FUNCTION	TYPE	DESCRIPTION	EEPROM/ I2C-SMBUS	DEFAULT
7:0	Enhanced Capabilities ID	RO	Read as 05h to indicate that this is message signal interrupt capability register.	No	05h
15:8	Next Item Pointer	RO	Indicates next capability pointer.	Yes	68h
16	MSI Enable	RW	0b: The function is prohibited from using MSI to request service 1b: The function is permitted to use MSI to request service and is prohibited from using its INTx # pin	No/Yes	0
19:17	Multiple Message Capable	RO	Do not support multiple messages.	No	000b
22:20	Multiple Message Enable	RW	Reset to 000b.	No/Yes	000b
23	64-bit address capable	RO	0b: The function is not capable of generating a 64-bit message address 1b: The function is capable of generating a 64-bit message address	No	1b
31:24	Reserved	RsvdP	Not Support.	No	00h

### 8.3.26 MESSAGE ADDRESS REGISTER – OFFSET 4Ch

BIT	FUNCTION	TYPE	DESCRIPTION	EEPROM/ I2C-SMBUS	DEFAULT
1:0	Reserved	RsvdP	Not Support.	No	00b
31:2	Message Address	RW	If the message enable bit is set, the contents of this register specify the DWORD aligned address for MSI memory write transaction.	No/Yes	0-0h

### 8.3.27 MESSAGE UPPER ADDRESS REGISTER – OFFSET 50h

BIT	FUNCTION	TYPE	DESCRIPTION	EEPROM/ I2C-SMBUS	DEFAULT
31:0	Message Upper Address	RW	This register is only effective if the device supports a 64-bit message address is set.	No/Yes	0000_0000h

### 8.3.28 MESSAGE DATA REGISTER – OFFSET 54h

BIT	FUNCTION	TYPE	DESCRIPTION	EEPROM/ I2C-SMBUS	DEFAULT
15:0	Message Data	RW	Message data.	No/Yes	0000h

### 8.3.29 PCI EXPRESS CAPABILITIES REGISTER – OFFSET 68h

BIT	FUNCTION	TYPE	DESCRIPTION	EEPROM/ I2C-SMBUS	DEFAULT
7:0	Enhanced Capabilities ID	RO	Read as 10h to indicate that these are PCI express enhanced capability registers.	No	10h
15:8	Next Item Pointer	RO	Pointer points to the SSID/SSVID Extended Capability Structure.	Yes	A4h
19:16	Capability Version	RO	Read as 2h to indicate the device is compliant to Revision .2.0 of <i>PCI Express Base Specifications</i> .	No	2h
23:20	Device/Port Type	RO	Indicates the type of PCI Express logical device.	No	0h
24	Slot Implemented	RO	Reset to 0b.	No	0
29:25	Interrupt Message Number	RO	Read as 0. No MSI messages are generated in the transparent mode.	No	00_000b
31:30	Reserved	RsvdP	Not Support.	No	00b

### 8.3.30 DEVICE CAPABILITIES REGISTER – OFFSET 6Ch

BIT	FUNCTION	TYPE	DESCRIPTION	EEPROM/ I2C-SMBUS	DEFAULT
2:0	Max_Payload_Size Supported	RO	Indicates the maximum payload size that the device can support for TLPs.  000b: 128 payload size 001b: 256 payload size 010b: 512 payload size	Yes	001b
4:3	Phantom Functions Supported	RO	Indicates the support for use of unclaimed function numbers as Phantom functions. Read as 00b, since the Switch does not act as a requester.	No	00b
5	Extended Tag Field Supported	RO	Indicates the maximum supported size of Tag field as a Requester. Read as 0, since the Switch does not act as a requester.	No	0
8:6	Endpoint L0s Acceptable Latency	RO	Acceptable total latency that an Endpoint can withstand due to the transition from L0s state to the L0 state. For Switch, the ASPM software would not check this value.	No	111b

BIT	FUNCTION	TYPE	DESCRIPTION	EEPROM/ I2C-SMBUS	DEFAULT
11:9	Endpoint L1 Acceptable Latency	RO	Acceptable total latency that an Endpoint can withstand due to the transition from L1 state to the L0 state. For Switch, the ASPM software would not check this value.	No	111b
14:12	Reserved	RsvdP	Not Support.	No	000b
15	Role Based Error Reporting	RO	When set, indicates that the device implements the functionality originally defined in the Error Reporting ECN.	Yes	1
17:16	Reserved	RsvdP	Not Support.	No	00b
25:18	Captured Slot Power Limit Value	RO	In combination with the Slot Power Limit Scale value, specifies the upper limit on power supplied by slot.  This value is set by the Set_Slot_Power_Limit message.	No	00h
27:26	Captured Slot Power Limit Scale	RO	Specifies the scale used for the Slot Power Limit Value.  This value is set by the Set_Slot_Power_Limit message.	No	00b
31:28	Reserved	RsvdP	Not Support.	No	0h

### 8.3.31 DEVICE CONTROL REGISTER – OFFSET 70h

BIT	FUNCTION	TYPE	DESCRIPTION	EEPROM/ I2C-SMBUS	DEFAULT
0	Correctable Error Reporting Enable	RW	0b: Disable Correctable Error Reporting 1b: Enable Correctable Error Reporting	No/Yes	0
1	Non-Fatal Error Reporting Enable	RW	0b: Disable Non-Fatal Error Reporting 1b: Enable Non-Fatal Error Reporting	No/Yes	0
2	Fatal Error Reporting Enable	RW	0b: Disable Fatal Error Reporting 1b: Enable Fatal Error Reporting	No/Yes	0
3	Unsupported Request Reporting Enable	RW	0b: Disable Unsupported Request Reporting 1b: Enable Unsupported Request Reporting	No/Yes	0
4	Enable Relaxed Ordering	RO	When set, it permits the device to set the Relaxed Ordering bit in the attribute field of transaction. Since the Switch can not either act as a requester or alter the content of packet it forwards, this bit always returns '0' when read.	No	0
7:5	Max_Payload_Size	RW	This field sets maximum TLP payload size for the device. Permissible values that can be programmed are indicated by the Max_Payload_Size Supported in the Device Capabilities register. Any value exceeding the Max_Payload_Size Supported written to this register results into clamping to the Max_Payload_Size Supported value.	No/Yes	000b
8	Extended Tag Field Enable	RsvdP	Not Support.	No	0
9	Phantom Function Enable	RsvdP	Not Support.	No	0
10	Auxiliary (AUX) Power PM Enable	RsvdP	Not Support.	No	0
11	Enable No Snoop	RsvdP	Not Support.	No	0
14:12	Max_Read_Request_Size	RO	This field sets the maximum Read Request size for the device as a Requester. Since the Switch does not generate read request by itself, these bits are hardwired to 0.	No	000b
15	Reserved	RsvdP	Not Support.	No	0

### 8.3.32 DEVICE STATUS REGISTER – OFFSET 70h

BIT	FUNCTION	TYPE	DESCRIPTION	EEPROM/ I2C-SMBUS	DEFAULT
16	Correctable Error Detected	RW1C	Asserted when correctable error is detected. Errors are logged in this register regardless of whether error reporting is enabled or not in the Device Control register.	No/Yes	0

BIT	FUNCTION	TYPE	DESCRIPTION	EEPROM/ I2C-SMBUS	DEFAULT
17	Non-Fatal Error Detected	RWIC	Asserted when non-fatal error is detected. Errors are logged in this register regardless of whether error reporting is enabled or not in the Device Control register.	No/Yes	0
18	Fatal Error Detected	RWIC	Asserted when fatal error is detected. Errors are logged in this register regardless of whether error reporting is enabled or not in the Device Control register.	No/Yes	0
19	Unsupported Request Detected	RWIC	Asserted when unsupported request is detected. Errors are logged in this register regardless of whether error reporting is enabled or not in the Device Control register.	No/Yes	0
20	AUX Power Detected	RO	Asserted when the AUX power is detected by the Switch	No	0
21	Transactions Pending	RO	Each port of Switch does not issue Non-posted Requests on its own behalf, so this bit is hardwired to 0.	No	0
31:22	Reserved	RsvdP	Not Support.	No	0-0h

### 8.3.33 LINK CAPABILITIES REGISTER – OFFSET 74h

BIT	FUNCTION	TYPE	DESCRIPTION	EEPROM/ I2C-SMBUS	DEFAULT
3:0	Maximum Link Speed	RO	Indicates the maximum speed of the Express link. 0001b: 2.5 Gb/s 0010b: 5.0Gb/s Others: Reserved	No	1h
9:4	Maximum Link Width	HWInt RO	Indicates the maximum width of the given PCIe Link. 01h: x1 link 04h: x4 link Others: Reserved	No	01h or 04h
11:10	Active State Power Management (ASPM) Support	RO	Indicates the level of ASPM supported on the given PCIe Link. Each port of Switch supports L0s and L1 entry.	Yes	01b
14:12	L0s Exit Latency	RO	Indicates the L0s exit latency for the given PCIe Link. The length of time this port requires to complete transition from L0s to L0 is in the range of 256ns to less than 512ns.	Yes	011b
17:15	L1 Exit Latency	RO	Indicates the L1 exit latency for the given PCIe Link. The length of time this port requires to complete transition from L1 to L0 is less than 1us.	Yes	000b
18	Clock Power Management	RO	A value of 1b indicates that component tolerates the removal of any reference clock via CLKREQ#.	Yes	1
19	Surprise Down Capability Enable	RsvdP	Not Support.	No	0
20	Data Link Layer Active Reporting Capable	RsvdP	Not Support.	No	0
21	Link BW Notify Capability	RsvdP	Not Support.	No	0
23:20	Reserved	RsvdP	Not Support.	No	0-0h
31:24	Port Number	RO	Indicates the NT-Port Number.	Yes	00h... port 0 01h... port 1 ...

### 8.3.34 LINK CONTROL REGISTER – OFFSET 78h

BIT	FUNCTION	TYPE	DESCRIPTION	EEPROM/ I2C-SMBUS	DEFAULT
1:0	Active State Power Management (ASPM) Control	RW	00b: ASPM is Disabled 01b: L0s Entry Enabled 10b: L1 Entry Enabled 11b: L0s and L1 Entry Enabled  Note that the receiver must be capable of entering L0s even when the field is disabled	No/Yes	00b
2	Reserved	RsvdP	Not Support.	No	0
3	Read Completion Boundary (RCB)	RO	Does not apply to PCI Express Switch. Returns '0' when read.	No	0
4	Link Disable	RsvdP	Not Support.	No	0
5	Retrain Link	RsvdP	Not Support.	No	0
6	Common Clock Configuration	RW	0b: The components at both ends of a link are operating with synchronous reference clock. 1b: The components at both ends of a link are operating with a distributed common reference clock	No/Yes	0
7	Extended Synch	RW	When set, it transmits 4096 FTS ordered sets in the L0s state for entering L0 state and transmits 1024 TS1 ordered sets in the L1 state for entering L0 state.	No/Yes	0
8	Enable Clock Power Management	RW	0b: clock power management is disable and must hold CLKREQ# low. 1b: device is permitted to use CLKREQ# to power manage link clock.	No/Yes	0
9	HW Autonomous Width Disable	RW	Reset to 0b.	No/Yes	0
10	Link Bandwidth Management Interrupt Enable	RW	Reset to 0b.	No/Yes	0
11	Link Autonomous Bandwidth Interrupt Enable	RW	Reset to 0b..	No/Yes	0
15:12	Reserved	RsvdP	Not Support.	No	00h

### 8.3.35 LINK STATUS REGISTER – OFFSET 78h

BIT	FUNCTION	TYPE	DESCRIPTION	EEPROM/ I2C-SMBUS	DEFAULT
19:16	Link Speed	RO	Indicate the negotiated speed of the Express link.  1h: link to 2.5 Gb/s 2h: link to 5.0 Gb/s	No	1h
25:20	Negotiated Link Width	RO	Indicates the negotiated width of the given PCIe link.  01h: x1 link 02h: x2 link 04h: x4 link	No	01h
26	Training Error	RsvdP	Not Support.	No	0
27	Link Training	RsvdP	Not Support.	No	0
28	Slot Clock Configuration	RO	0b: the Switch uses an independent clock corresponsive of the presence of a reference on the connector 1b: the Switch uses the same reference clock that the platform provides on the connector	Yes	1
29	Data Link Layer Link Active	RsvdP	Not Support.	No	0
30	Link Bandwidth Management Status	RO	Reset to 0b.	No	0
31	Link Autonomous Bandwidth Status	RO	Reset to 0b.	No	0

### 8.3.36 LINK CONTROL REGISTER 2 – OFFSET 94h

BIT	FUNCTION	TYPE	DESCRIPTION	EEPROM/ I2C-SMBUS	DEFAULT
31:0	Reserved	RsvdP	Not Support.	No	000b

### 8.3.37 LINK CONTROL REGISTER 2 – OFFSET 98h

BIT	FUNCTION	TYPE	DESCRIPTION	EEPROM/ I2C-SMBUS	DEFAULT
3:0	Target Link Speed	RW	0001b: target link speed set to 2.5 Gb/s 0010b: target link speed set to 5.0 Gb/s Others: Reserved	No/Yes	2h
4	Enter Compliance	RW	1b: enter compliance mode	No/Yes	0
5	Hardware Autonomous Speed Disable	RW	Not Support.	No	0
6	Selectable De-Emphasis	RO	Not Support.	No	0
9:7	Tran Margin	RW	Test used only.	No/Yes	000b
10	Enter Modify Compliance	RW	Not Support.	No	0
11	Compliance SOS	RW	Not Support.	No	0
12	Compliance Deemp	RW	Not Support.	No	0
15:13	Reserved	RsvdP	Not Support.	No	000b

### 8.3.38 LINK STATUS REGISTER 2 – OFFSET 98h

BIT	FUNCTION	TYPE	DESCRIPTION	EEPROM/ I2C-SMBUS	DEFAULT
16	Current De-emphasis level	RO	0b: -6dB 1b: -3.5dB	No	0
31:17	Link status 2	RO	Not Support.	No	0-0h

### 8.3.39 SSID/SSVID CAPABILITIES REGISTER – OFFSET A4h

BIT	FUNCTION	TYPE	DESCRIPTION	EEPROM/ I2C-SMBUS	DEFAULT
7:0	SSID/SSVID Capabilities ID	RO	Read as 0Dh to indicate that these are SSID/SSVID capability registers.	No	0Dh
15:8	Next Item Pointer	RO	Indicates next capability pointer.	Yes	C8h
31:16	Reserved	RsvdP	Not Support.	No	0000h

### 8.3.40 SUBSYSTEM VENDOR ID REGISTER – OFFSET A8h

BIT	FUNCTION	TYPE	DESCRIPTION	EEPROM/ I2C-SMBUS	DEFAULT
15:0	SSVID	RO	It indicates the sub-system vendor id.	Yes	12D8h



### 8.3.41 SUBSYSTEM ID REGISTER – OFFSET A8h

BIT	FUNCTION	TYPE	DESCRIPTION	EEPROM/ I2C-SMBUS	DEFAULT
31:16	SSID	RO	It indicates the sub-system device id.	Yes	8608h

### 8.3.42 VENDOR SPECIFIC CAPABILITIES REGISTER – OFFSET C8h

BIT	FUNCTION	TYPE	DESCRIPTION	EEPROM/ I2C-SMBUS	DEFAULT
7:0	Enhanced Capabilities ID	RO	Read as 09h to indicate that these are vendor specific capability registers.	No	09h
15:8	Next Item Pointer	RO	Read as 00h. No other ECP registers.	No	00h
31:16	Length Information	RO	The length field provides the information for number of bytes in the capability structure.	No	0038h

### 8.3.43 VENDOR SPECIFIC HEADER REGISTER – OFFSET CCh

BIT	FUNCTION	TYPE	DESCRIPTION	EEPROM/ I2C-SMBUS	DEFAULT
31:0	Reserved	RsvdP	Reset to 0380 0002h.	No	0380 0002h

### 8.3.44 NT PORT LINK INTERFACE BAR 0-1 CONFIGURATION REGISTER – OFFSET E4h

BIT	FUNCTION	TYPE	DESCRIPTION	EEPROM/ I2C-SMBUS	DEFAULT
1:0	BAR0 Type	RW	00b: Disable BAR0/1 01b: Reserved 10b: BAR0 is implemented as a 32-bit Memory BAR 11b: BAR0/1 is implemented as a 64-bit Memory BAR	Yes	10b
2	BAR0 Prefetchable	RW	0b: Non Prefetchable 1b: Prefetchable	Yes	0
31:3	Reserved	RsvdP	Not Support.	No	0-0h

### 8.3.45 NT PORT LINK INTERFACE BAR 2 CONFIGURATION REGISTER – OFFSET E8h

BIT	FUNCTION	TYPE	DESCRIPTION	EEPROM/ I2C-SMBUS	DEFAULT
0	Type Selector	RsvdP	Not Support.	No	0
2:1	BAR2 Type	RW	00b: BAR2 is implemented as a 32 bit Memory BAR 10b: BAR2/3 is implemented as a 64-bit Memory BAR	No/Yes	00b
3	Prefetchable	RW	0b: Non Prefetchable 1b: Prefetchable	No/Yes	0
19:4	Reserved	RsvdP	Not Support.	No	0 000h
30:20	BAR2 Size	RW	To specify BAR2 size. 0b: Corresponding BAR2 bits are RO bits that always return 0 1b: Corresponding BAR2 bits are RW bits	No/Yes	0-0h
31	BAR 2 Enable	RW	Valid when bits[2:1]=00b. 0b: Disable BAR2 1b: Enable BAR2	No/Yes	0

BIT	FUNCTION	TYPE	DESCRIPTION	EEPROM/ I2C-SMBUS	DEFAULT
	BAR 2 Size	RW	Includes with bits[30:20] when tis BAR is used as a 64-bit BAR (bits[2:1]=10b).		

### 8.3.46 NT PORT LINK INTERFACE BAR 2-3 CONFIGURATION REGISTER – OFFSET ECh

BIT	FUNCTION	TYPE	DESCRIPTION	EEPROM/ I2C-SMBUS	DEFAULT
0	Type Selector	RsvdP	Not Support.	No	0
2:1	BAR3 Type	RO	00b: BAR3 is implemented as a 32-bit Memory BAR.	No	00b
3	Prefetchable	RW	0b: Non Prefetchable 1b: Prefetchable	No/Yes	0
19:4	Upper 32 Bits	RsvdP	Not Support when E8h[2:1]=00b.	No	0_000h
		RW	When E8h[2:1]=10b, BAR2/3 are used as a 64-bit BAR, bit[31:0] (including bit[19:4]) are used as the upper 32-bits.	No/Yes	0_000h
30:20	BAR3 Size	RW	To specify BAR3 size. 0b: Corresponding BAR3 bits are RO bits that always return 0 1b: Corresponding BAR3 bits are RW bits	No/Yes	000h
31	BAR 3 Enable	RW	Valid when E8h[2:1]=00b. 0b: Disable BAR3 1b: Enable BAR3	No/Yes	0
	64-Bit BAR	RW	Valid when E8h[2:1]=10b. 0b: BAR2/3 is disabled, all BAR2/3 bits read 0. 1b: BAR2/3 is enabled as a 64-bit BAR.		

### 8.3.47 NT PORT LINK INTERFACE BAR 4 CONFIGURATION REGISTER – OFFSET F0h

BIT	FUNCTION	TYPE	DESCRIPTION	EEPROM/ I2C-SMBUS	DEFAULT
0	Type Selector	RsvdP	Not Support.	No	0
2:1	BAR4 Type	RW	00b: BAR4 is implemented as a 32 bit Memory BAR 10b: BAR4/5 is implemented as a 64-bit Memory BAR	No/Yes	00b
3	Prefetchable	RW	0b: Non Prefetchable 1b: Prefetchable	No/Yes	0
19:4	Reserved	RsvdP	Not Support.	No	0_000h
30:20	BAR4 Size	RW	To specify BAR4 size. 0b: Corresponding BAR4 bits are RO bits that always return 0 1b: Corresponding BAR4 bits are RW bits	No/Yes	0-0h
31	BAR4 Enable	RW	Valid when bis[2:1]=00b. 0b: Disable BAR4 1b: Enable BAR4	No/Yes	0
	BAR 4 Size	RW	Includes with bits[30:20] when tis BAR is used as a 64-bit BAR (bits[2:1]=10b).		

### 8.3.48 NT PORT LINK INTERFACE BAR 4-5 CONFIGURATION REGISTER – OFFSET F4h

BIT	FUNCTION	TYPE	DESCRIPTION	EEPROM/ I2C-SMBUS	DEFAULT
0	Type Selector	RsvdP	Not Support.	No	0
2:1	BAR5 Type	RO	00b: BAR5 is implemented as a 32-bit Memory BAR.	No	00b
3	Prefetchable	RW	0b: Non Prefetchable 1b: Prefetchable	No/Yes	0
19:4	Upper 32 Bits	RsvdP	Not Support when F0h[2:1]=00b.	No	0_000h
		RW	When F0h[2:1]=10b, BAR4/5 are used as a 64-bit BAR, bit[31:0] (including bit[19:4]) are used as the upper 32-bits.	No/Yes	0_000h
30:20	BAR5 Size	RW	To specify BAR5 size. 0b: Corresponding BAR5 bits are RO bits that always return 0 1b: Corresponding BAR5 bits are RW bits	No/Yes	000h
31	BAR 5 Enable	RW	Valid when F0h[2:1]=00b. 0b: Disable BAR5. 1b: Enable BAR5.	No/Yes	0
	64-Bit BAR	RW	Valid when F0h[2:1]=10b. 0b: BAR4/5 is disabled, all BAR4/5 bits read 0. 1b: BAR4/5 is enabled as a 64-bit BAR.		

### 8.3.49 DEVICE SERIAL NUMBER ENHANCED CAPABILITY HEADER REGISTER – OFFSET 100h

BIT	FUNCTION	TYPE	DESCRIPTION	EEPROM/ I2C-SMBUS	DEFAULT
15:0	Extended Capabilities ID	RO	Read as 0003h to indicate that these are PCI express extended capability registers for device serial number extend capability register.	No	0003h
19:16	Capability Version	RO	Must be 1h for this version.	No	1h
31:20	Next Capability Offset	RO	Indicates next capability pointer.	Yes	FB4h

### 8.3.50 DEVICE SERIAL NUMBER LOWER DW REGISTER – OFFSET 104h

BIT	FUNCTION	TYPE	DESCRIPTION	EEPROM/ I2C-SMBUS	DEFAULT
31:0	Device serial number 1 <sup>st</sup> DW	RO	First dword for device serial number.	Yes	0000_0000h

### 8.3.51 DEVICE SERIAL NUMBER HIGHTER DW REGISTER – OFFSET 108h

BIT	FUNCTION	TYPE	DESCRIPTION	EEPROM/ I2C-SMBUS	DEFAULT
31:0	Device serial number 2 <sup>nd</sup> DW	RO	Second dword for device serial number.	Yes	0000_0000h

### 8.3.52 PCI EXPRESS POWER BUDGETING ENHANCED CAPABILITY HEADER REGISTER – OFFSET 138h

BIT	FUNCTION	TYPE	DESCRIPTION	EEPROM/ I2C-SMBUS	DEFAULT
15:0	Extended Capabilities ID	RO	Read as 0004h to indicate that these are PCI express extended capability registers for power budgeting.	No	0004h
19:16	Capability Version	RO	Must be 1h for this version.	No	01h
31:20	Next Capability Offset	RO	Indicates next capability pointer.	Yes	148h

### 8.3.53 DATA SELECT REGISTER – OFFSET 13Ch

BIT	FUNCTION	TYPE	DESCRIPTION	EEPROM/ I2C-SMBUS	DEFAULT
7:0	Data Selection	RW	It indexes the power budgeting data reported through the data register.  When 00h, it selects D0 Max power budget When 01h, it selects D0 Sustained power budget Other values would return zero power budgets, which means not supported.	No/Yes	00h
31:8	Reserved	RsvdP	Not Support.	No	0-0h

### 8.3.54 POWER BUDGETING DATA REGISTER – OFFSET 140h

BIT	FUNCTION	TYPE	DESCRIPTION	EEPROM/ I2C-SMBUS	DEFAULT
7:0	Base Power	RO	It specifies the base power value in watts. This value represents the required power budget in the given operation condition.	Yes	04h if 13Ch[0]=0 03h if 13Ch[0]=1
9:8	Data Scale	RO	It specifies the scale to apply to the base power value.	Yes	00b
12:10	PM Sub State	RO	It specifies the power management sub state of the given operation condition. It is initialized to the default sub state.	No	000b
14:13	PM State	RO	It specifies the power management state of the given operation condition.  It defaults to the D0 power state.	Yes	00b
17:15	Type	RO	It specifies the type of the given operation condition. It defaults to the Maximum power state.	No/Yes	111b if 13Ch[0]=0 011b if 13Ch[0]=1
20:18	Power Rail	RO	It specifies the power rail of the given operation condition..	No	010b
31:21	Reserved	RsvdP	Not Support.	No	0-0h

### 8.3.55 POWER BUDGET CAPABILITY REGISTER – OFFSET 144h

BIT	FUNCTION	TYPE	DESCRIPTION	EEPROM/ I2C-SMBUS	DEFAULT
0	System Allocated	RO	When set, it indicates that the power budget for the device is included within the system power budget.	Yes	1
31:1	Reserved	RsvdP	Not Support.	No	0-0h

### 8.3.56 PCI EXPRESS VIRTUAL CHANNEL ENHANCED CAPABILITY HEADER REGISTER – OFFSET 148h

BIT	FUNCTION	TYPE	DESCRIPTION	EEPROM/I2C-SMBUS	DEFAULT
15:0	Extended Capabilities ID	RO	Read as 0002h to indicate that these are PCI express extended capability registers for virtual channel.	No	02h
19:16	Capability Version	RO	Read as 1h.	No	01h
31:20	Next Capability Offset	RO	Read as 000h. No other ECP registers.	No	000h

### 8.3.57 PORT VC CAPABILITY REGISTER 1 – OFFSET 14Ch

BIT	FUNCTION	TYPE	DESCRIPTION	EEPROM/I2C-SMBUS	DEFAULT
2:0	Extended VC Count	RO	It indicates the number of extended Virtual Channels in addition to the default VC supported by the Switch.	Yes	000b
3	Reserved	RsvdP	Not Support.	No	0
6:4	Low Priority Extended VC Count	RO	It indicates the number of extended Virtual Channels in addition to the default VC belonging to the low-priority VC (LPVC) group.	Yes	000b
7	Reserved	RsvdP	Not Support.	No	0
9:8	Reference Clock	RO	It indicates the reference clock for Virtual Channels that support time-based WRR Port Arbitration. Defined encoding is 00b for 100 ns reference clock.	No	00b
11:10	Port Arbitration Table Entry Size	RO	Read as 10b to indicate the size of Port Arbitration table entry in the device is 4 bits.	No	10b
31:12	Reserved	RsvdP	Not Support.	No	0000 0h

### 8.3.58 PORT VC CAPABILITY REGISTER 2 – OFFSET 150h

BIT	FUNCTION	TYPE	DESCRIPTION	EEPROM/I2C-SMBUS	DEFAULT
7:0	VC Arbitration Capability	RO	It indicates the types of VC Arbitration supported by the device for the LPVC group. This field is valid when LPVC is greater than 0. The Switch supports Hardware fixed arbitration scheme, e.g., Round Robin and Weight Round Robin arbitration with 32 phases in LPVC.	No	03h
23:8	Reserved	RsvdP	Not Support.	No	0000h
31:24	VC Arbitration Table Offset	RO	It indicates the location of the VC Arbitration Table as an offset from the base address of the Virtual Channel Capability register in the unit of DQWD (16 bytes).	No	00h if VC1=0 04h if VC1=1

### 8.3.59 PORT VC CONTROL REGISTER – OFFSET 154h

BIT	FUNCTION	TYPE	DESCRIPTION	EEPROM/I2C-SMBUS	DEFAULT
0	Load VC Arbitration Table	RW	When set, the programmed VC Arbitration Table is applied to the hardware. This bit always returns '0' when read.	Yes	0
3:1	VC Arbitration Select	RW	This field is used to configure the VC Arbitration by selecting one of the supported VC Arbitration schemes. The valid values for the schemes supported by Switch are 0b and 1b. Other value than these written into this register will be treated as default.	No/Yes	000b
15:4	Reserved	RsvdP	Not Support.	No	000h

### 8.3.60 VC STATUS REGISTER – OFFSET 154h

BIT	FUNCTION	TYPE	DESCRIPTION	EEPROM/ I2C-SMBUS	DEFAULT
16	VC Arbitration Table Status	RO	When set, it indicates that any entry of the VC Arbitration Table is written by software. This bit is cleared when hardware finishes loading values stored in the VC Arbitration Table after the bit of “Load VC Arbitration Table” is set.	No	0
31:17	Reserved	RsvdP	Not Support.	No	0-0h

### 8.3.61 VC RESOURCE CAPABILITY REGISTER (0) – OFFSET 158h

BIT	FUNCTION	TYPE	DESCRIPTION	EEPROM/ I2C-SMBUS	DEFAULT
7:0	Port Arbitration Capability	RO	It indicates the types of Port Arbitration supported by the VC resource. The Switch supports Hardware fixed arbitration scheme, e.g., Round Robin, Weight Round Robin (WRR) arbitration with 128 phases (3~4 enabled ports) and Time-based WRR with 128 phases (3~4 enabled ports). Note that the Time-based WRR is only valid in VC1.	No	03h
13:8	Reserved	RsvdP	Not Support.	No	00_0000h
14	Advanced Packet Switching	RO	When set, it indicates the VC resource only supports transaction optimized for Advanced Packet Switching (AS).	No	0
15	Reject Snoop Transactions	RO	This bit is not applied to PCIe Switch.	No	0
22:16	Maximum Time Slots	RO	It indicates the maximum numbers of time slots (minus one) are allocated for Isochronous traffic.	No	3Fh
23	Reserved	RsvdP	Not Support.	No	0
31:24	Port Arbitration Table Offset	RO	It indicates the location of the Port Arbitration Table (n) as an offset from the base address of the Virtual Channel Capability register in the unit of DQWD (16 bytes).	No	05h

### 8.3.62 VC RESOURCE CONTROL REGISTER (0) – OFFSET 15Ch

BIT	FUNCTION	TYPE	DESCRIPTION	EEPROM/ I2C-SMBUS	DEFAULT
7:0	TC/VC Map	RW	This field indicates the TCs that are mapped to the VC resource. Bit locations within this field correspond to TC values. When the bits in this field are set, it means that the corresponding TCs are mapped to the VC resource.	Yes	FFh
15:8	Reserved	RsvdP	Not Support.	No	00h
16	Load Port Arbitration Table	RW	When set, the programmed Port Arbitration Table is applied to the hardware. This bit always returns 0b when read.	No/Yes	0
19:17	Port Arbitration Select	RW	This field is used to configure the Port Arbitration by selecting one of the supported Port Arbitration schemes. The permissible values for the schemes supported by Switch are 000b and 011b at VC0, other value than these written into this register will be treated as default.	No/Yes	000b
23:20	Reserved	RsvdP	Not Support.	No	0h
26:24	VC ID	RO	This field assigns a VC ID to the VC resource.	No	000b
30:27	Reserved	RsvdP	Not Support.	No	0h
31	VC Enable	RO	0b: it disables this Virtual Channel 1b: it enables this Virtual Channel	No	1

### 8.3.63 VC RESOURCE STATUS REGISTER (0) – OFFSET 160h

BIT	FUNCTION	TYPE	DESCRIPTION	EEPROM/ I2C-SMBUS	DEFAULT
15:0	Reserved	RsvdP	Not Support.	No	0000h
16	Port Arbitration Table Status	RO	When set, it indicates that any entry of the Port Arbitration Table is written by software. This bit is cleared when hardware finishes loading values stored in the Port Arbitration Table after the bit of “Load Port Arbitration Table” is set.	No	0
17	VC Negotiation Pending	RO	When set, it indicates that the VC resource is still in the process of negotiation. This bit is cleared after the VC negotiation is complete.	No	0
31:18	Reserved	RsvdP	Not Support.	No	0-0h

### 8.3.64 VC RESOURCE CAPABILITY REGISTER (1) – OFFSET 164h

BIT	FUNCTION	TYPE	DESCRIPTION	EEPROM/ I2C-SMBUS	DEFAULT
7:0	Port Arbitration Capability	RO	It indicates the types of Port Arbitration supported by the VC resource. The Switch supports Hardware fixed arbitration scheme, e.g., Round Robin, Weight Round Robin (WRR) arbitration with 128 phases (3~4 enabled ports) and Time-based WRR with 128 phases (3~4 enabled ports). Note that the Time-based WRR is only valid in VC1.	No	00h if VC1=0 13h if VC1=1
13:8	Reserved	RsvdP	Not Support.	No	0-0h
14	Advanced Packet Switching	RO	When set, it indicates the VC resource only supports transaction optimized for Advanced Packet Switching (AS).	No	0
15	Reject Snoop Transactions	RO	This bit is not applied to PCIe Switch.	No	0
22:16	Maximum Time Slots	RO	It indicates the maximum numbers of time slots (minus one) are allocated for Isochronous traffic.	Yes	00h if VC1=0 3Fh if VC1=1
23	Reserved	RsvdP	Not Support.	No	0
31:24	Port Arbitration Table Offset	RO	It indicates the location of the Port Arbitration Table (n) as an offset from the base address of the Virtual Channel Capability register in the unit of DQWD (16 bytes).	No	00h if VC1=0 06h if VC1=1

### 8.3.65 VC RESOURCE CONTROL REGISTER (1) – OFFSET 168h

BIT	FUNCTION	TYPE	DESCRIPTION	EEPROM/ I2C-SMBUS	DEFAULT
7:0	TC/VC Map	RW	This field indicates the TCs that are mapped to the VC resource. Bit locations within this field correspond to TC values. When the bits in this field are set, it means that the corresponding TCs are mapped to the VC resource. Bit 0 of this field is read-only and must be set to “0” for the VC1.	Yes	00h
15:8	Reserved	RsvdP	Not Support.	No	0-0h
16	Load Port Arbitration Table	RW	When set, the programmed Port Arbitration Table is applied to the hardware. This bit always returns 0b when read.	No/Yes	0
19:17	Port Arbitration Select	RW	This field is used to configure the Port Arbitration by selecting one of the supported Port Arbitration schemes. The permissible values for the schemes supported by Switch are 000b, 011b and 100b at VC1, other value than these written into this register will be treated as default.	No/Yes	000b
23:20	Reserved	RsvdP	Not Support.	No	0h
26:24	VC ID	RW	This field assigns a VC ID to the VC resource.	No/Yes	000b if VC1=0 001b if VC1=1
30:27	Reserved	RsvdP	Not Support.	No	0h
31	VC Enable	RW	0b: it disables this Virtual Channel 1b: it enables this Virtual Channel	No/Yes	0

### 8.3.66 VC RESOURCE STATUS REGISTER (1) – OFFSET 16Ch

BIT	FUNCTION	TYPE	DESCRIPTION	EEPROM/ I2C-SMBUS	DEFAULT
15:0	Reserved	RsvdP	Not Support.	No	0000h
16	Port Arbitration Table Status	RO	When set, it indicates that any entry of the Port Arbitration Table is written by software. This bit is cleared when hardware finishes loading values stored in the Port Arbitration Table after the bit of “Load Port Arbitration Table” is set.	No	0
17	VC Negotiation Pending	RO	When set, it indicates that the VC resource is still in the process of negotiation. This bit is cleared after the VC negotiation is complete.	No	0
31:18	Reserved	RsvdP	Not Support.	No	0-0h

### 8.3.67 VC ARBITRATION TABLE REGISTER – OFFSET 188h

The VC arbitration table is a read-write register array that contains a table for VC arbitration. Each table entry allocates four bits, of which three bits are used to represent VC ID and one bit is reserved. A total of 32 entries are used to construct the VC arbitration table. The layout for this register array is shown below.

**Table 8-4 Register Array Layout for VC Arbitration**

31 - 28	27 - 24	23 - 20	19 - 16	15 - 12	11 - 8	7 - 4	3 - 0	Byte Location	EEPROM/ I2C-SMBUS	DEFAULT
Phase [7]	Phase [6]	Phase [5]	Phase [4]	Phase [3]	Phase [2]	Phase [1]	Phase [0]	00h	No/Yes	0000_0000h
Phase [15]	Phase [14]	Phase [13]	Phase [12]	Phase [11]	Phase [10]	Phase [9]	Phase [8]	04h	No/Yes	0000_0000h
Phase [23]	Phase [22]	Phase [21]	Phase [20]	Phase [19]	Phase [18]	Phase [17]	Phase [16]	08h	No/Yes	0000_0000h
Phase [31]	Phase [30]	Phase [29]	Phase [28]	Phase [27]	Phase [26]	Phase [25]	Phase [24]	0Ch	No/Yes	0000_0000h

### 8.3.68 PORT ARBITRATION TABLE REGISTER (0) and (1) – OFFSET 198h and 1A8h

The Port arbitration table is a read-write register array that contains a table for Port arbitration. Each table entry allocates two bits to represent Port Number. The table entry size is dependent on the number of enabled ports (refer to bit 10 and 11 of Port VC capability register 1). The arbitration table contains 32 entries if three or four ports are to be enabled. The following table shows the register array layout for the size of entry equal to two.

**Table 8-5 Table Entry Size in 4 Bits**

31 - 24	23 - 16	15 - 8	7 - 0	Byte Location	EEPROM/ I2C-SMBUS	DEFAULT
Phase [7:6]	Phase [5:4]	Phase [3:2]	Phase [1:0]	00h	No/Yes	0000_0000h
Phase [15:14]	Phase [13:12]	Phase [11:10]	Phase [9:8]	04h	No/Yes	0000_0000h
Phase [23:22]	Phase [21:20]	Phase [19:18]	Phase [17:16]	08h	No/Yes	0000_0000h
Phase [31:30]	Phase [29:28]	Phase [27:26]	Phase [25:24]	0Ch	No/Yes	0000_0000h



### 8.3.69 XPIP\_CSR 0 REGISTER – OFFSET 844h

BIT	FUNCTION	TYPE	DESCRIPTION	EEPROM/ I2C-SMBUS	DEFAULT
31:0	XPIP_CSR0	RW	XPIP CSR 0 value. Bit[2]: Cross_Link_En.  These bits always return '0' when read.	Yes	0400_1060h

### 8.3.70 XPIP\_CSR 1 REGISTER – OFFSET 848h

BIT	FUNCTION	TYPE	DESCRIPTION	EEPROM/ I2C-SMBUS	DEFAULT
31:0	XPIP_CSR1	RW	XPIP CSR 1 value.  These bits always return '0' when read.	Yes	0400_0800h

### 8.3.71 DECODE VGA REGISTER – OFFSET 84Ch

BIT	FUNCTION	TYPE	DESCRIPTION	EEPROM/ I2C-SMBUS	DEFAULT
30:0	Reserved	RsvdP	Not Support.	No	0-0h
31	Decode VGA Enable	RO	0b: Disable VGA decode 1b: Enable VGA decode  This bit always returns '0' when read.	Yes	1

### 8.3.72 XPIP\_CSR 2 REGISTER – OFFSET 854h

BIT	FUNCTION	TYPE	DESCRIPTION	EEPROM/ I2C-SMBUS	DEFAULT
7:0	FTS Number	RW	These bits always return '0' when read.	Yes	80h
9:8	Scrambler Control	RW	These bits always return '0' when read.	Yes	00b
10	L0s	RW	This bit always returns '0' when read.	Yes	0
11	Compliance to Detect	RW	This bit always returns '0' when read.	Yes	0
13:12	Change_Speed_Sel	RW	These bits always return '0' when read.	Yes	00b
14	Change_Speed_En	RW	This bit always returns '0' when read.	Yes	0
31:15	Reserved	RsvdP	Not Support.	No	0_0000h

### 8.3.73 PHY PARAMETER 2 REGISTER – OFFSET 858h

BIT	FUNCTION	TYPE	DESCRIPTION	EEPROM/ I2C-SMBUS	DEFAULT
7:0	Reserved	RsvdP	Not Support.	No	27h
8	P_CDR_FREQLOO P_EN	RW	This bit always returns '0' when read.	Yes	1
10:9	P_CDR_ THRESHOLD	RW	These bits always return '0' when read.	Yes	10b
12:11	P_CDR_FREQLOO P_GAIN	RW	These bits always return '0' when read.	Yes	11b
15:13	Reserved	RsvdP	Not Support.	No	000b
16	P_DRV_LVL_MGN DELATA_EN	RW	This bit always returns '0' when read.	Yes	0

BIT	FUNCTION	TYPE	DESCRIPTION	EEPROM/ I2C-SMBUS	DEFAULT
17	P_DRV_LVL_NOM DELATA_EN	RW	This bit always returns '0' when read.	Yes	0
18	P_EMP_POST_MG N_DELATA_EN	RW	This bit always returns '0' when read.	Yes	0
19	P_EMP_POST_NO M_DELATA_EN	RW	This bit always returns '0' when read.	Yes	0
21:20	P_RX_SIGDET_ LVL	RW	Set the receiver signal detection threshold. Please refer to Section 6.1.2 for more detail information.  These bits always return '0' when read.	Yes	01b
25:22	P_RX_EQ_1	RW	Set the receiver equalization for GEN1 link. Please refer to Section 6.1.3 for more detail information.  These bits always return '0' when read.	Yes	0h
29:26	P_RX_EQ_2	RW	Set the receiver equalization for GEN2 link. Please refer to Section 6.1.3 for more detail information.  These bits always return '0' when read.	Yes	0h
30	P_TXSWING	RW	Set the transmitter swing. Please refer to Section 6.1.4 for more detail information.  0b: full voltage swing with de-emphasis 1b: half voltage swing without de-emphasis  This bit always returns '0' when read.	Yes	0
31	Reserved	RsvdP	Not Support.	No	0

### 8.3.74 PHY PARAMETER 3 REGISTER – OFFSET 85Ch

BIT	FUNCTION	TYPE	DESCRIPTION	EEPROM/ I2C-SMBUS	DEFAULT
6:0	PHY Parameter 3 (Per Lane)	RW	PHY's Lane mode.  These bits always return '0' when read.	Yes	00h
14:7	Reserved	RsvdP	Not Support.	No	00h
31:15	PHY Parameter 3 (Per Port)	RW	PHY's delta value setting.  These bits always return '0' when read.	Yes	0001h

### 8.3.75 XPIP\_CSR 3 REGISTER – OFFSET 864h

BIT	FUNCTION	TYPE	DESCRIPTION	EEPROM/ I2C-SMBUS	DEFAULT
31:0	XPIP_CSR3	RW	XPIP CSR 3 value.  These bits always return '0' when read.	Yes	000F_0000h

### 8.3.76 XPIP\_CSR 5 REGISTER – OFFSET 86Ch

BIT	FUNCTION	TYPE	DESCRIPTION	EEPROM/ I2C-SMBUS	DEFAULT
29:0	XPIP_CSR5[29:0]	RW	Bit[10]: Default ACK Latency Timer Enable 0b: disable default ack latency timer 1b: enable default ack latency timer  These bits always return '0' when read.	Yes	3308_0008h
30	DO_CHG_DATA	RW	DO_CHG_DATA_RATE_CTRL.	Yes	0

	RATE_CTRL		This bit always returns '0' when read.		
31	Gen1_Cap_Only	RW	0b: report GEN2 capability 1b: report GEN1 capability  This bit always returns '0' when read.	Yes	0

### 8.3.77 OPERATION MODE REGISTER – OFFSET 874h (Global)

BIT	FUNCTION	TYPE	DESCRIPTION	EEPROM/ I2C-SMBUS	DEFAULT
15:0	Operation Mode	HwInt RO	Bit[0]: Memory Bist Bit[1]: IDDRB Bit[2]: FAST_MODE Bit[3]: DEBUG_MODE Bit[4]: PHY_MODE Bit[6:5]: PORT_CFG[1:0] Bit[8:7]: Reserved Bit[9]: PLCSEL Bit[10]: SCAN_MODE Bit[15:11]: Reserved	No	0043h for 208 mode 0023h for 508 mode 0003h for 808 mode
31:16	Reserved	RsvdP	Not Support.	No	0000h

### 8.3.78 MAC\_CSR REGISTER – OFFSET 890h

BIT	FUNCTION	TYPE	DESCRIPTION	EEPROM/ I2C-SMBUS	DEFAULT
15:0	Reserved	RsvdP	Not Support.	No	0000h
31:16	MAC_CSR	RW	These bits always return '0' when read.	Yes	0004h

### 8.3.79 POWER SAVING DISABLE REGISTER – OFFSET 8A4h

BIT	FUNCTION	TYPE	DESCRIPTION	EEPROM/ I2C-SMBUS	DEFAULT
0	Power Saving Disable	RW	Disable power saving.  This bit always returns '0' when read.	Yes	0
31:1	Reserved	RsvdP	Not Support.	No	0-0h

### 8.3.80 TRANSACTION LAYER CSR REGISTER – OFFSET 8A8h

BIT	FUNCTION	TYPE	DESCRIPTION	EEPROM/ I2C-SMBUS	DEFAULT
0	Egress_Reqcredit_ Starve	RW	Test used only.	Yes	1
1	MF_Credit_Update_ Dis	RW	Test used only.	Yes	0
2	MC_Cap_Dis	RW	Test used only.	Yes	0
3	MEM_Sharing_Dis	RO	Test used only.	Yes	0
31:4	Reserved	RsvdP	Not Support.	No	0-0h

### 8.3.81 REPLAY TIME-OUT COUNTER REGISTER – OFFSET 8ACh

BIT	FUNCTION	TYPE	DESCRIPTION	EEPROM/ I2C-SMBUS	DEFAULT
11:0	User Replay Timer	RW	A 12-bit register contains a user-defined value. These bits always return '0' when read.	Yes	000h
12	Enable User Replay Timer	RW	When asserted, the user-defined replay time-out value is be employed. This bit always returns '0' when read.	Yes	0
15:13	Reserved	RsvdP	Not Support.	No	000b

### 8.3.82 ACKNOWLEDGE LATENCY TIMER REGISTER – OFFSET 8ACh

BIT	FUNCTION	TYPE	DESCRIPTION	EEPROM/ I2C-SMBUS	DEFAULT
29:16	User ACK Latency Timer	RW	A 14-bit register contains a user-defined value. These bits always return '0' when read.	Yes	0-0h
30	Enable User ACK Latency	RW	When asserted, the user-defined ACK latency value is be employed. This bit always returns '0' when read.	Yes	0
31	Reserved	RsvdP	Not Support.	No	0

### 8.3.83 PORT MISC 0 REGISTER – OFFSET 8B0h

BIT	FUNCTION	TYPE	DESCRIPTION	EEPROM/ I2C-SMBUS	DEFAULT
7:0	Reserved	RsvdP	Not Support.	No	00h
13:8	Power Management Control Parameter	RW	Power Management Control parameter.	Yes	00_0001b
14	RX Polarity Inversion Disable	RW	0b: enable rx polarity inversion circuit 1b: disable rx polarity inversion circuit	Yes	0
15	Compliance Pattern Parity Control Disable	RW	0b: enable compliance pattern parity control 1b: disable compliance pattern parity control	Yes	0
31:16	Reserved	RsvdP	Not Support	No	0000h

### 8.3.84 PORT MISC 1 REGISTER – OFFSET 8B4h

BIT	FUNCTION	TYPE	DESCRIPTION	EEPROM/ I2C-SMBUS	DEFAULT
7:0	Reserved	RsvdP	Not Support.	No	00h
8:9	DO_CHG_DATA_CNT_SEL	RW	The trying number for doing change data rate. These bits always return '0' when read.	Yes	00b
10	Port Disable	RW	Disable this port. This bit always returns '0' when read.	Yes	0
15:11	Reserved	RsvdP	Not Support.	No	0_0000b

### 8.3.85 XPIP\_CSR 6 REGISTER – OFFSET 8B4h

BIT	FUNCTION	TYPE	DESCRIPTION	EEPROM/ I2C-SMBUS	DEFAULT
23:16	XPIP_CSR6	RW	XPIP_CSR 6 Value. These bits always return '0' when read.	Yes	78h

### 8.3.86 XPIP\_CSR 7 REGISTER – OFFSET 8B4h

BIT	FUNCTION	TYPE	DESCRIPTION	EEPROM/ I2C-SMBUS	DEFAULT
25:24	REV_TS_CTR	RW	Test used only. These bits always return '0' when read.	Yes	00
29:26	MAC Control Parameter	RW	Test used only. These bits always return '0' when read.	Yes	0h
30	Line_Loopback	RW	Test used only. This bit always returns '0' when read.	No	0
31	P35_GEN2_MODE	RW	Test used only. This bit always returns '0' when read.	Yes	0

### 8.3.87 PORT MISC 2 REGISTER – OFFSET 8B8h

BIT	FUNCTION	TYPE	DESCRIPTION	EEPROM/ I2C-SMBUS	DEFAULT
0	Change_Role_En	RW	Test used only. This bit always returns '0' when read.	Yes	0
1	IPCore_Role	RW	Test used only. This bit always returns '0' when read.	Yes	0
31:2	Reserved	RsvdP	Not Support.	No	0-0h

### 8.3.88 VENDOR SPECIFIC CAPABILITIES HEADER REGISTER – OFFSET C34h

BIT	FUNCTION	TYPE	DESCRIPTION	EEPROM/ I2C-SMBUS	DEFAULT
15:0	Extended Capabilities ID	RO	Read as 000Bh to indicate that these are PCI express extended capability registers for vendor specific registers.	No	000Bh
19:16	Capability Version	RO	Read as 1h.	No	1h
31:20	Next Capability Offset	RO	Read as 000h. No other ECP registers.	No	000h

### 8.3.89 VENDOR SPECIFIC HEADER REGISTER – OFFSET C38h

BIT	FUNCTION	TYPE	DESCRIPTION	EEPROM/ I2C-SMBUS	DEFAULT
31:0	Vendor Specific Header	RO	Reset to 0780_0003h.	No	0780_0003h

### 8.3.90 MEMORY BAR 2 ADDRESS TRANSLATION REGISTER – OFFSET C3Ch

BIT	FUNCTION	TYPE	DESCRIPTION	EEPROM/ I2C-SMBUS	DEFAULT
19:0	Reserved	RsvdP	Not Support.	No	0_0000h
31:20	Memory BAR 2 Address Translation	RW	Valid when BAR 2 is enabled (offset E8h[31]=1).	Yes	000h

### 8.3.91 MEMORY BAR 3 ADDRESS TRANSLATION REGISTER – OFFSET C40h

BIT	FUNCTION	TYPE	DESCRIPTION	EEPROM/ I2C-SMBUS	DEFAULT
19:0	Reserved	RsvdP	Not Support.	No	000h
31:20	Memory BAR 3 Address Translation	RW	Valid when BAR 3 is enabled (ECh[31]=1).	Yes	000h

### 8.3.92 MEMORY BAR4 ADDRESS TRANSLATION REGISTER – OFFSET C44h

BIT	FUNCTION	TYPE	DESCRIPTION	EEPROM/ I2C-SMBUS	DEFAULT
19:0	Reserved	RsvdP	Not Support.	No	0_0000h
31:20	Memory BAR 4 Address Translation	RW	Valid when BAR 4 is enabled (offset F0h[31]=1).	Yes	000h

### 8.3.93 MEMORY BAR 5 ADDRESS TRANSLATION REGISTER – OFFSET C48h

BIT	FUNCTION	TYPE	DESCRIPTION	EEPROM/ I2C-SMBUS	DEFAULT
19:0	Reserved	RsvdP	Not Support.	No	000h
31:0	Memory BAR 5 Address Translation	RW	Valid when BAR 5 is enabled (F4h[31]=1).	Yes	000h

### 8.3.94 VIRTUAL IF IRQ SET REGISTER – OFFSET C4Ch

BIT	FUNCTION	TYPE	DESCRIPTION	EEPROM/ I2C-SMBUS	DEFAULT
15:0	Set IRQ	RW	Set virtual interface IRQ.	No/Yes	0000h
31:16	Reserved	RsvdP	Not Support.	No	0000h

### 8.3.95 VIRTUAL IF IRQ CLEAR REGISTER – OFFSET C50h

BIT	FUNCTION	TYPE	DESCRIPTION	EEPROM/ I2C-SMBUS	DEFAULT
15:0	Clear IRQ	RWIC	Clear virtual interface IRQ.	No/Yes	0000h
31:16	Reserved	RsvdP	Not Support.	No	0000h

### 8.3.96 VIRTUAL IF IRQ MASK SET REGISTER – OFFSET C54h

BIT	FUNCTION	TYPE	DESCRIPTION	EEPROM/ I2C-SMBUS	DEFAULT
15:0	Set IRQ Mask	RW	Set virtual interface interrupt IRQ mask.	No/Yes	FFFFh
31:16	Reserved	RsvdP	Not Support.	No	0000h

### 8.3.97 VIRTUAL IF IRQ MASK CLEAR REGISTER – OFFSET C58h

BIT	FUNCTION	TYPE	DESCRIPTION	EEPROM/ I2C-SMBUS	DEFAULT
15:0	Clear IRQ Mask	RW1C	Clear virtual interface interrupt IRQ mask.	No/Yes	0000h
31:16	Reserved	RsvdP	Not Support.	No	0000h

### 8.3.98 LINK IF IRQ SET REGISTER – OFFSET C5Ch

BIT	FUNCTION	TYPE	DESCRIPTION	EEPROM/ I2C-SMBUS	DEFAULT
15:0	Set IRQ	RW	Set link interface IRQ.	No/Yes	0000h
31:16	Reserved	RsvdP	Not Support.	No	0000h

### 8.3.99 LINK IF IRQ CLEAR REGISTER – OFFSET C60h

BIT	FUNCTION	TYPE	DESCRIPTION	EEPROM/ I2C-SMBUS	DEFAULT
15:0	Clear IRQ	RW1C	Clear link interface IRQ.	No/Yes	0000h
31:16	Reserved	RsvdP	Not Support.	No	0000h

### 8.3.100 LINK IF IRQ MASK SET REGISTER – OFFST C64h

BIT	FUNCTION	TYPE	DESCRIPTION	EEPROM/ I2C-SMBUS	DEFAULT
15:0	Set IRQ Mask	RW	Set link interface interrupt IRQ mask.	No/Yes	FFFFh
31:16	Reserved	RsvdP	Not Support.	No	0000h

### 8.3.101 LINK IF IRQ MASK CLEAR REGISTER – OFFSET C68h

BIT	FUNCTION	TYPE	DESCRIPTION	EEPROM/ I2C-SMBUS	DEFAULT
15:0	Clear IRQ Mask	RW1C	Clear link interface interrupt IRQ mask.	No/Yes	0000h
31:16	Reserved	RsvdP	Not Support.	No	0000h

### 8.3.102 SCRATCHPAD 0 REGISTER – OFFSET C6Ch

BIT	FUNCTION	TYPE	DESCRIPTION	EEPROM/ I2C-SMBUS	DEFAULT
31:0	Scratchpad 0	RW	Scratchpad 0 register.	No/Yes	0000 0000h

### 8.3.103 SCRATCHPAD 1 REGISTER – OFFSET C70h

BIT	FUNCTION	TYPE	DESCRIPTION	EEPROM/ I2C-SMBUS	DEFAULT
31:0	Scratchpad 1	RW	Scratchpad 1 register.	No/Yes	0000_0000h

### 8.3.104 SCRATCHPAD 2 REGISTER – OFFSET C74h

BIT	FUNCTION	TYPE	DESCRIPTION	EEPROM/ I2C-SMBUS	DEFAULT
31:0	Scratchpad 2	RW	Scratchpad 2 register.	No/Yes	0000_0000h

### 8.3.105 SCRATCHPAD 3 REGISTER – OFFSET C78h

BIT	FUNCTION	TYPE	DESCRIPTION	EEPROM/ I2C-SMBUS	DEFAULT
31:0	Scratchpad 3	RW	Scratchpad 3 register.	No/Yes	0000_0000h

### 8.3.106 SCRATCHPAD 4 REGISTER – OFFSET C7Ch

BIT	FUNCTION	TYPE	DESCRIPTION	EEPROM/ I2C-SMBUS	DEFAULT
31:0	Scratchpad 4	RW	Scratchpad 4 register.	No/Yes	0000_0000h

### 8.3.107 SCRATCHPAD 5 REGISTER – OFFSET C80h

BIT	FUNCTION	TYPE	DESCRIPTION	EEPROM/ I2C-SMBUS	DEFAULT
31:0	Scratchpad 5	RW	Scratchpad 5 register.	No/Yes	0000_0000h

### 8.3.108 SCRATCHPAD 6 REGISTER – OFFSET C84h

BIT	FUNCTION	TYPE	DESCRIPTION	EEPROM/ I2C-SMBUS	DEFAULT
31:0	Scratchpad 6	RW	Scratchpad 6 register.	No/Yes	0000_0000h

### 8.3.109 SCRATCHPAD 7 REGISTER – OFFSTE C88h

BIT	FUNCTION	TYPE	DESCRIPTION	EEPROM/ I2C-SMBUS	DEFAULT
31:0	Scratchpad 8	RW	Scratchpad 8 register.	No/Yes	0000_0000h



### 8.3.110 VIRTUAL PORT 32-BITS LTT ENTRY 0-7 – OFFSET D94h to DB0h

**Table 8-6 Virtual Port 32-Bits LTT Entry 0-7 Register Locations**

CFG OFFSET	LTT Entry_n	CFG OFFSET	LTT Entry_n
D94h	0	DA4h	4
D98h	1	DA8h	5
D9Ch	2	DACH	6
DA0h	3	DB0h	7

**Table 8-7 Virtual Port 32-Bits LTT Entry\_n (n=0 through 7)**

BIT	FUNCTION	TYPE	DESCRIPTION	EEPROM/ I2C-SMBUS	DEFAULT
15:0	ReqID	RW	Bit[2:0]: function number Bit[7:3]: device number Bit[15:8]: bus number	No/Yes	0000h
29:16	Reserved	RsvdP	Not Support.	No	0-0h
30	LUT Entry_n No Snoop Enable	RsvdP	Not Support.	No	0
31	LUT Entry_n Enable	RW	0b: disable 1b: enable	No/Yes	0

### 8.3.111 LINK PORT 16-BITS LTT ENTRY 0-31 REGISTER – OFFSET DB4h – DF4h

**Table 8-8 Link Port 16-Bits LTT Entry 0-31 Register Locations**

CFG OFFSET	LTT Entry_n	CFG OFFSET	LTT Entry_n
DB4h	0-1	DD4h	16-17
DB8h	2-3	DD8h	18-19
DBCh	4-5	DDCh	20-21
DC0h	6-7	DE0h	22-23
DC4h	8-9	DE4h	24-25
DC8h	10-11	DE8h	26-27
DCCh	12-13	DECh	28-29
DD0h	14-15	DF0h	30-31

**Table 8-9 Link Port 16-Bits LTT Entry\_n\_m (n\_m 0-1 to 30-31)**

BIT	FUNCTION	TYPE	DESCRIPTION	EEPROM/ I2C-SMBUS	DEFAULT
0	LUT Entry_n Enable	RW	0b: disable 1b: enable	No/Yes	0
1	LUT Entry_n No Snoop Enable	RsvdP	Not Support.	No	0
2	Reserved	RsvdP	Not Support.	No	0
15:3	ReqID	RW	Bit[7:3]: device number Bit[15:8]: device id	No/Yes	00h
16	LUT Entry_m Enable	RW	0b: disable 1b: enable	No/Yes	0
17	LUT Entry_m No Snoop Enable	RW	0b: disable 1b: enable	No/Yes	0
18	Reserved	RsvdP	Not Support.	No	0
31:19	ReqID	RW	Bit[7:3]: device number Bit[15:8]: device id	No/Yes	00h

### 8.3.112 FAIL-OVER CSR REGISTER – OFFSET DF4h

BIT	FUNCTION	TYPE	DESCRIPTION	EEPROM/ I2C-SMBUS	DEFAULT
0	Pri Linkdown Force	RW	Test used only.	Yes	0
1	2nd Linkdown Force	RW	Test used only.	Yes	0
2	Failover Enable	RW	Test used only.	Yes	0
3	Disable Hot Reset	RW	Test used only.	Yes	0
31:4	Reserved	RsvdP	Not Support.	No	0-0h

### 8.3.113 EEPROM\_SCRATCHPAD REGISTER – OFFSET FB0h

BIT	FUNCTION	TYPE	DESCRIPTION	EEPROM/ I2C-SMBUS	DEFAULT
31:0	EEPROM_Scratchpad	RO	Test used only.	Yes	0000_0000h

### 8.3.114 PCI EXPRESS ADVANCED ERROR REPORTING ENHANCED CAPABILITY HEADER REGISTER – OFFSET FB4h

BIT	FUNCTION	TYPE	DESCRIPTION	EEPROM/ I2C-SMBUS	DEFAULT
15:0	Extended Capabilities ID	RO	Read as 0001h to indicate that these are PCI express extended capability registers for advance error reporting.	No	0001h
19:16	Capability Version	RO	Read as 1h.	No	1h
31:20	Next Capability Offset	RO	Indicates next capability pointer.	No/Yes	138h

### 8.3.115 UNCORRECTABLE ERROR STATUS REGISTER – OFFSET FB8h

BIT	FUNCTION	TYPE	DESCRIPTION	EEPROM/ I2C-SMBUS	DEFAULT
0	Training Error Status	RW1C	When set, indicates that the Training Error event has occurred.	No/Yes	0
3:1	Reserved	RsvdP	Not Support.	No	000
4	Data Link Protocol Error Status	RW1C	When set, indicates that the Data Link Protocol Error event has occurred.	No/Yes	0
11:5	Reserved	RsvdP	Not Support.	No	0-0b
12	Poisoned TLP Status	RW1C	When set, indicates that a Poisoned TLP has been received or generated.	No/Yes	0
13	Flow Control Protocol Error Status	RW1C	When set, indicates that the Flow Control Protocol Error event has occurred.	No/Yes	0
14	Completion Timeout Status	RW1C	When set, indicates that the Completion Timeout event has occurred.	No/Yes	0
15	Completer Abort Status	RW1C	When set, indicates that the Completer Abort event has occurred.	No/Yes	0
16	Unexpected Completion Status	RW1C	When set, indicates that the Unexpected Completion event has occurred.	No/Yes	0
17	Receiver Overflow Status	RW1C	When set, indicates that the Receiver Overflow event has occurred.	No/Yes	0
18	Malformed TLP Status	RW1C	When set, indicates that a Malformed TLP has been received.	No/Yes	0
19	ECRC Error Status	RW1C	When set, indicates that an ECRC Error has been detected.	No/Yes	0
20	Unsupported Request Error Status	RW1C	When set, indicates that an Unsupported Request event has occurred.	No/Yes	0
21	ACS Violation Status	RW1C	When set, indicates that an ACS Violation event has occurred	No/Yes	0

BIT	FUNCTION	TYPE	DESCRIPTION	EEPROM/ I2C-SMBUS	DEFAULT
22	Reserved	RsvdP	Not Support.	No	0
23	MC Blocked TLP Status	RW1C	When set, indicates that an MC Blocked TLP event has occurred.	No/Yes	0
31:24	Reserved	RsvdP	Not Support.	No	00h

### 8.3.116 UNCORRECTABLE ERROR MASK REGISTER – OFFSET FBCh

BIT	FUNCTION	TYPE	DESCRIPTION	EEPROM/ I2C-SMBUS	DEFAULT
0	Training Error Mask	RW	When set, the Training Error event is not logged in the Header Log register and not issued as an Error Message to RC either.	No/Yes	0
3:1	Reserved	RsvdP	Not Support.	No	000b
4	Data Link Protocol Error Mask	RW	When set, the Data Link Protocol Error event is not logged in the Header Log register and not issued as an Error Message to RC either.	No/Yes	0
11:5	Reserved	RsvdP	Not Support.	No	0-0b
12	Poisoned TLP Mask	RW	When set, an event of Poisoned TLP is not logged in the Header Log register and not issued as an Error Message to RC either.	No/Yes	0
13	Flow Control Protocol Error Mask	RW	When set, the Flow Control Protocol Error event is not logged in the Header Log register and not issued as an Error Message to RC either.	No/Yes	0
14	Completion Timeout Mask	RW	When set, the Completion Timeout event is not logged in the Header Log register and not issued as an Error Message to RC either.	No/Yes	0
15	Completer Abort Mask	RW	When set, the Completer Abort event is not logged in the Header Log register and not issued as an Error Message to RC either.	No/Yes	0
16	Unexpected Completion Mask	RW	When set, the Unexpected Completion event is not logged in the Header Log register and not issued as an Error Message to RC either.	No/Yes	0
17	Receiver Overflow Mask	RW	When set, the Receiver Overflow event is not logged in the Header Log register and not issued as an Error Message to RC either.	No/Yes	0
18	Malformed TLP Mask	RW	When set, an event of Malformed TLP is not logged in the Header Log register and not issued as an Error Message to RC either.	No/Yes	0
19	ECRC Error Mask	RW	When set, an event of ECRC Error is not logged in the Header Log register and not issued as an Error Message to RC either.	No/Yes	0
20	Unsupported Request Error Mask	RW	When set, the Unsupported Request event is not logged in the Header Log register and not issued as an Error Message to RC either.	No/Yes	0
21	ACS Violation Mask	RW	When set, the ACS Violation event is not logged in the Header Log register and not issued as an Error Message to RC either.	No/Yes	0
22	Reserved	RsvdP	Not Support.	No	0
23	MC Blocked TLP Mask	RW1C	When set, the MC Blocked TLP event is not logged in the Header Log register and not issued as an Error Message to RC either.	No/Yes	0
31:24	Reserved	RsvdP	Not Support.	No	00h

### 8.3.117 UNCORRECTABLE ERROR SEVERITY REGISTER – OFFSET FC0h

BIT	FUNCTION	TYPE	DESCRIPTION	EEPROM/ I2C-SMBUS	DEFAULT
0	Training Error Severity	RW	0b: Non-Fatal 1b: Fatal	No/Yes	1
3:1	Reserved	RsvdP	Not Support.	No	000b
4	Data Link Protocol Error Severity	RW	0b: Non-Fatal 1b: Fatal	No/Yes	1
11:5	Reserved	RsvdP	Not Support.	No	0-0b
12	Poisoned TLP Severity	RW	0b: Non-Fatal 1b: Fatal	No/Yes	0

BIT	FUNCTION	TYPE	DESCRIPTION	EEPROM/ I2C-SMBUS	DEFAULT
13	Flow Control Protocol Error Severity	RW	0b: Non-Fatal 1b: Fatal	No/Yes	1
14	Completion Timeout Error Severity	RW	0b: Non-Fatal 1b: Fatal	No/Yes	0
15	Completer Abort Severity	RW	0b: Non-Fatal 1b: Fatal	No/Yes	0
16	Unexpected Completion Severity	RW	0b: Non-Fatal 1b: Fatal	No/Yes	0
17	Receiver Overflow Severity	RW	0b: Non-Fatal 1b: Fatal	No/Yes	1
18	Malformed TLP Severity	RW	0b: Non-Fatal 1b: Fatal	No/Yes	1
19	ECRC Error Severity	RW	0b: Non-Fatal 1b: Fatal	No/Yes	0
20	Unsupported Request Error Severity	RW	0b: Non-Fatal 1b: Fatal	No/Yes	0
21	ACS Violation Severity	RW	0b: Non-Fatal 1b: Fatal	No/Yes	0
22	Reserved	RsvdP	Not Support.	No	0
23	MC Blocked TLP Severity	RW	0b: Not-Fatal 1b: Fatal	No/Yes	0
31:24	Reserved	RsvdP	Not Support.	No	00h

### 8.3.118 CORRECTABLE ERROR STATUS REGISTER – OFFSET FC4 h

BIT	FUNCTION	TYPE	DESCRIPTION	EEPROM/ I2C-SMBUS	DEFAULT
0	Receiver Error Status	RW1C	When set, the Receiver Error event is detected.	No/Yes	0
5:1	Reserved	RsvdP	Not Support.	No	0 000b
6	Bad TLP Status	RW1C	When set, the event of Bad TLP has been received is detected.	No/Yes	0
7	Bad DLLP Status	RW1C	When set, the event of Bad DLLP has been received is detected.	No/Yes	0
8	REPLAY_NUM Rollover status	RW1C	When set, the REPLAY_NUM Rollover event is detected.	No/Yes	0
11:9	Reserved	RsvdP	Not Support.	No	000b
12	Replay Timer Timeout status	RW1C	When set, the Replay Timer Timeout event is detected.	No/Yes	0
13	Advisory Non-Fatal Error status	RW1C	When set, the Advisory Non-Fatal Error event is detected.	No/Yes	0
31:14	Reserved	RsvdP	Not Support.	No	0-0h

### 8.3.119 CORRECTABLE ERROR MASK REGISTER – OFFSET FC8 h

BIT	FUNCTION	TYPE	DESCRIPTION	EEPROM/ I2C-SMBUS	DEFAULT
0	Receiver Error Mask	RW	When set, the Receiver Error event is not logged in the Header Log register and not issued as an Error Message to RC either.	No/Yes	0
5:1	Reserved	RsvdP	Not Support.	No	0 000b
6	Bad TLP Mask	RW	When set, the event of Bad TLP has been received is not logged in the Header Log register and not issued as an Error Message to RC either.	No/Yes	0
7	Bad DLLP Mask	RW	When set, the event of Bad DLLP has been received is not logged in the Header Log register and not issued as an Error Message to RC either.	No/Yes	0
8	REPLAY_NUM Rollover Mask	RW	When set, the REPLAY_NUM Rollover event is not logged in the Header Log register and not issued as an Error Message to RC either.	No/Yes	0

BIT	FUNCTION	TYPE	DESCRIPTION	EEPROM/ I2C-SMBUS	DEFAULT
11:9	Reserved	RsvdP	Not Support.	No	000b
12	Replay Timer Timeout Mask	RW	When set, the Replay Timer Timeout event is not logged in the Header Log register and not issued as an Error Message to RC either.	No/Yes	0
13	Advisory Non-Fatal Error Mask	RW	When set, the Advisory Non-Fatal Error event is not logged in the Header Long register and not issued as an Error Message to RC either.	No/Yes	1
31:14	Reserved	RsvdP	Not Support.	No	0-0h

### 8.3.120 ADVANCE ERROR CAPABILITIES AND CONTROL REGISTER – OFFSET FCCh

BIT	FUNCTION	TYPE	DESCRIPTION	EEPROM/ I2C-SMBUS	DEFAULT
4:0	First Error Pointer	RO	It indicates the bit position of the first error reported in the Uncorrectable Error Status register. Reset to 5'd0.	No	0_0000b
5	ECRC Generation Capable	RO	When set, it indicates the Switch has the capability to generate ECRC.	No	1
6	ECRC Generation Enable	RW	When set, it enables the generation of ECRC when needed.	No/Yes	0
7	ECRC Check Capable	RO	When set, it indicates the Switch has the capability to check ECRC.	No	1
8	ECRC Check Enable	RW	When set, the function of checking ECRC is enabled..	No/Yes	0
31:9	Reserved	RsvdP	Not Support.	No	0-0h

### 8.3.121 HEADER LOG REGISTER – OFFSET From FD0h to FDCh

BIT	FUNCTION	TYPE	DESCRIPTION	EEPROM/ I2C-SMBUS	DEFAULT
31:0	1 <sup>st</sup> DWORD	RO	Hold the 1st DWORD of TLP Header. The Head byte is in big endian.	No	0000-0000h
63:32	2 <sup>nd</sup> DWORD	RO	Hold the 2nd DWORD of TLP Header. The Head byte is in big endian.	No	0000-0000h
95:64	3 <sup>rd</sup> DWORD	RO	Hold the 3rd DWORD of TLP Header. The Head byte is in big endian.	No	0000-0000h
127:96	4 <sup>th</sup> DWORD	RO	Hold the 4th DWORD of TLP Header. The Head byte is in big endian.	No	0000-0000h

### 8.4 NON TRANSPARENT PORT VIRTUAL INTERFACE CONFIGURATION REGISTERS – NT Mode Only

When the port of the Switch is set to operate at the non-transparent mode, it is represented by an Other Bridge that implements type 0 configuration space header. The following table details the allocation of the register fields of the PCI 2.3 compatible type 0 configuration space header.

31 – 24	23 – 16	15 – 8	7 – 0	BYTE OFFSET
Device ID		Vendor ID		00h
Primary Status		Command		04h
Class Code		Revision ID		08h
Reserved	Header Type	Reserved	Cache Line Size	0Ch
BAR 0				10h
BAR 1				14h
BAR 2				18h
BAR 3				1Ch
BAR 4				20h
BAR 5				24h
Reserved				28h
SSID		SSVID		2Ch
Reserved		Reserved		30h
Reserved			Capability Pointer to 40h	34h
Reserved				38h
Reserved		Interrupt Pin	Interrupt Line	3Ch
Power Management Capabilities		Next Item Pointer=48h	Capability ID=01h	40h
PM Data	PPB Support Extensions	Power Management Data		44h
Message Control		Next Item Pointer=68h	Capability ID=05h	48h
Message Address				4Ch
Message Upper Address				50h
Reserved		Message Data		54h
Reserved				58h – 64h
PCI Express Capabilities Register		Next Item Pointer=A4h	Capability ID=10h	68h
Device Capabilities				6Ch
Device Status		Device Control		70h
Link Capabilities				74h
Link Status		Link Control		78h
Reserved				7Ch - 90h
Link Capabilities 2				94h
Link Status 2		Link Control 2		98h
Reserved				9Ch – A0h
Reserved		Next Item Pointer=C8h	SSID/SSVID Capability ID=0Dh	A4h
SSID		SSVID		A8h
Reserved				ACh – C4h
Length		Next Item Pointer=00h	Vendor Specific Capability ID=09h	C8h
Reserved				CCh
NT Port Virtual Interface BAR 0-1 Configuration				D0h
NT Port Virtual Interface BAR 2 Configuration				D4h
NT Port Virtual Interface BAR 2-3 Configuration				D8h
NT Port Virtual Interface BAR 4 Configuration				DCh
NT Port Virtual Interface BAR 4-5 Configuration				E0h
Reserved				E4h - FCh

Other than the PCI 2.3 compatible configuration space header, the Switch also implements PCI express extended configuration space header, which includes advanced error reporting, virtual channel, and power budgeting capability registers. The following table details the allocation of the register fields of PCI express extended capability space header. The first extended capability always begins at offset 100h with a PCI Express Enhanced Capability header and the rest of capabilities are located at an offset greater than 0FFh relative to the beginning of PCI compatible configuration space.

31 – 24	23 – 16	15 – 8	7 – 0	BYTE OFFSET
Next Capability Offset=C34h	Cap. Version	PCI Express Extended Capability ID=0003h		100h
Serial Number Lower DW				104h
Serial Number Upper DW				108h
Reserved				10Ch – C30h
Next Capability Offset=000h	Cap. Version	PCI Express Extended Capability ID=000Bh		C34h
Vendor Specific Header				C38h
Translation BAR 2				C3Ch
Translation BAR 3				C40h
Translation BAR 4				C44h
Translation BAR 5				C48h
Reserved	Virtual IF IRQ Set			C4Ch
Reserved	Virtual IF IRQ Clear			C50h
Reserved	Virtual IF IRQ Mask Set			C54h
Reserved	Virtual IF IRQ Mask Clear			C58h
Reserved	Link IF IRQ Set			C5Ch
Reserved	Link IF IRQ Clear			C60h
Reserved	Link IF IRQ Mask Set			C64h
Reserved	Link IF IRQ Mask Clear			C68h
Scratchpad 0				C6Ch
Scratchpad 1				C70h
Scratchpad 2				C74h
Scratchpad 3				C78h
Scratchpad 4				C7Ch
Scratchpad 5				C80h
Scratchpad 6				C84h
Scratchpad 7				C88h
Reserved				C8Ch – D90h
Virtual Port 32-Bits LTT Entry 0				D94h
Virtual Port 32-Bits LTT Entry 1				D98h
Virtual Port 32-Bits LTT Entry 2				D9Ch
Virtual Port 32-Bits LTT Entry 3				DA0h
Virtual Port 32-Bits LTT Entry 4				DA4h
Virtual Port 32-Bits LTT Entry 5				DA8h
Virtual Port 32-Bits LTT Entry 6				DACH
Virtual Port 32-Bits LTT Entry 7				DB0h
Link Port 16-Bits LTT Entry 0-1				DB4h
Link Port 16-Bits LTT Entry 2-3				DB8h
Link Port 16-Bits LTT Entry 4-5				DBCh
Link Port 16-Bits LTT Entry 6-7				DC0h
Link Port 16-Bits LTT Entry 8-9				DC4h
Link Port 16-Bits LTT Entry 10-11				DC8h
Link Port 16-Bits LTT Entry 12-13				DCCCh
Link Port 16-Bits LTT Entry 14-15				DD0h
Link Port 16-Bits LTT Entry 16-17				DD4h
Link Port 16-Bits LTT Entry 18-19				DD8h
Link Port 16-Bits LTT Entry 20-21				DDCh
Link Port 16-Bits LTT Entry 22-23				DE0h
Link Port 16-Bits LTT Entry 24-25				DE4h
Link Port 16-Bits LTT Entry 26-27				DE8h
Link Port 16-Bits LTT Entry 28-29				DECh
Link Port 16-Bits LTT Entry 30-31				DF0h
Fail-Over CSR				DF4h
Reserved				DF8 - FFCh

### 8.4.1 VENDOR ID REGISTER – OFFSET 00h

BIT	FUNCTION	TYPE	DESCRIPTION	EEPROM/ I2C-SMBUS	DEFAULT
15:0	Vendor ID	RO	Identifies Pericom as the vendor of this device.	Yes	12D8h

### 8.4.2 DEVICE ID REGISTER – OFFSET 00h

BIT	FUNCTION	TYPE	DESCRIPTION	EEPROM/ I2C-SMBUS	DEFAULT
31:16	Device ID	RO	Identifies this device as the PI7C9X2G808PR.	Yes	8608h

### 8.4.3 COMMAND REGISTER – OFFSET 04h

BIT	FUNCTION	TYPE	DESCRIPTION	EEPROM/ I2C-SMBUS	DEFAULT
0	I/O Space Enable	RW	0b: Ignores I/O transactions on the primary interface 1b: Enables responses to I/O transactions on the primary interface	No/Yes	0
1	Memory Space Enable	RW	0b: Ignores memory transactions on the primary interface 1b: Enables responses to memory transactions on the primary interface	No/Yes	0
2	Bus Master Enable	RW	0b: Does not initiate memory or I/O transactions on the upstream port and handles as an Unsupported Request (UR) to memory and I/O transactions on the downstream port. For Non-Posted Requests, a completion with UR completion status must be returned 1b: Enables the Switch Port to forward memory and I/O Read/Write transactions in the upstream direction	No/Yes	0
3	Special Cycle Enable	RsvdP	Not Support.	No	0
4	Memory Write And Invalidate Enable	RsvdP	Not Support.	No	0
5	VGA Palette Snoop Enable	RsvdP	Not Support.	No	0
6	Parity Error Response Enable	RW	0b: Switch0b: Switch may ignore any parity errors that it detects and continue normal operation 1b: Switch must take its normal action when a parity error is detected	No/Yes	0
7	Wait Cycle Control	RsvdP	Not Support.	No	0
8	SERR# enable	RW	0b: Disables the reporting of Non-fatal and Fatal errors detected by the Switch to the Root Complex 1b: Enables the Non-fatal and Fatal error reporting to Root Complex	No/Yes	0
9	Fast Back-to-Back Enable	RsvdP	Not Support.	No	0
10	Interrupt Disable	RW	0b: Enable to generate INTx Interrupt Messages 1b: Disable to generate INTx Interrupt Messages	No/Yes	0
15:11	Reserved	RsvdP	Not Support.	No	0000_0b

### 8.4.4 PRIMARY STATUS REGISTER – OFFSET 04h

BIT	FUNCTION	TYPE	DESCRIPTION	EEPROM/ I2C-SMBUS	DEFAULT
18:16	Reserved	RsvdP	Not Support.	No	000b
19	Interrupt Status	RO	Indicates that an INTx Interrupt Message is pending internally to the device. In the Switch, the forwarding of INTx messages from the downstream device of the Switch port is not reflected in this bit. Must be hardwired to 0.	No	0



BIT	FUNCTION	TYPE	DESCRIPTION	EEPROM/ I2C-SMBUS	DEFAULT
20	Capabilities List	RO	Set to 1b to enable support for the capability list (offset 34h is the pointer to the data structure).	No	1
21	66MHz Capable	RsvdP	Not Support	No	0
22	Reserved	RsvdP	Not Support.	No	0
23	Fast Back-to-Back Capable	RsvdP	Not Support.	No	0
24	Master Data Parity Error	RW1C	Set to 1b (by a requester) whenever a Parity error is detected or forwarded on the primary side of the port in a Switch.  If the Parity Error Response Enable bit is cleared, this bit is never set.	No/Yes	0
26:25	DEVSEL# timing	RsvdP	Not Support.	No	00b
27	Signaled Target Abort	RW1C	Set to 1b (by a requester) whenever a Completer Abort is detected.	No/Yes	0
28	Received Target Abort	RsvdP	Not Support.	No	0
29	Received Master Abort	RsvdP	Not Support.	No	0
30	Signaled System Error	RW1C	Set to 1b when the Switch sends an ERR_FATAL or ERR_NONFATAL Message, and the SERR Enable bit in the Command register is 1.	No	0
31	Detected Parity Error	RW1C	Set to 1b whenever the primary side of the port in a Switch receives a Poisoned TLP.	No/Yes	0

#### 8.4.5 REVISION ID REGISTER – OFFSET 08h

BIT	FUNCTION	TYPE	DESCRIPTION	EEPROM/ I2C-SMBUS	DEFAULT
7:0	Revision	RO	Indicates revision number of device.	No/Yes	00h

#### 8.4.6 CLASS CODE REGISTER – OFFSET 08h

BIT	FUNCTION	TYPE	DESCRIPTION	EEPROM/ I2C-SMBUS	DEFAULT
15:8	Programming Interface	RO	Read as 00h to indicate no programming interfaces have been defined for PCI-to-PCI Bridges.	No	00h
23:16	Sub-Class Code	RO	Read as 80h to indicate device is an Other Bridge.	No	80h
31:24	Base Class Code	RO	Read as 06h to indicate device is a Bridge device.	No	06h

#### 8.4.7 CACHE LINE REGISTER – OFFSET 0Ch

BIT	FUNCTION	TYPE	DESCRIPTION	EEPROM/ I2C-SMBUS	DEFAULT
7:0	Cache Line Size	RW	The cache line size register is set by the system firmware and the operating system cache line size. This field is implemented by PCI Express devices as a RW field for legacy compatibility, but it has no impact on any PCI Express device functionality.	No/Yes	00h

#### 8.4.8 PRIMARY LATENCY TIMER REGISTER – OFFSET 0Ch

BIT	FUNCTION	TYPE	DESCRIPTION	EEPROM/ I2C-SMBUS	DEFAULT
15:8	Primary Latency Timer	RsvdP	Not Support.	No	00h

#### 8.4.9 HEADER TYPE REGISTER – OFFSET 0Ch

BIT	FUNCTION	TYPE	DESCRIPTION	EEPROM/ I2C-SMBUS	DEFAULT
23:16	Header Type	RO	Read as 00h to indicate that the register layout conforms to Type 0 Configuration Header for the NT Port.	No	00h

#### 8.4.10 BAR 0 REGISTER – OFFSET 10h

BIT	FUNCTION	TYPE	DESCRIPTION	EEPROM/ I2C-SMBUS	DEFAULT
0	Memory Space Indicator	RO	Reset to 0b to indicate the Base Address register maps NT Port Configuration registers into Memory Space.	No	0
2:1	Memory Map Type	RO	00b: support 32-bit Memory Space. 10b: support 64-bit Memory Space.	No	00b
3	Prefetchable	RO	Reset to 0b to indicate NT Port Configuration registers maps to Non-Prefetchable Memory Space.	No	0
16:4	Reserved	RsvdP	Not Support.	No	0-0h
31:17	Base Address 0	RW	Use this Memory base address to map the NT-Port Configuration registers.	No/Yes	0-0h

#### 8.4.11 BAR 1 REGISTER – OFFSET 14h

BIT	FUNCTION	TYPE	DESCRIPTION	EEPROM/ I2C-SMBUS	DEFAULT
31:0	Base Address 1	RO	When 10h[2:1]=00b, BAR 0 is not enabled as a 64-bit BAR.	No	0
		RW	When 10h[2:1]=10b, for 64-bit addressing (BAR 0/1), BAR 1 extends BAR 0 to provide the upper 32 Address bits.	No/Yes	0

#### 8.4.12 BAR 2 REGISTER – OFFSET 18h

BIT	FUNCTION	TYPE	DESCRIPTION	EEPROM/ I2C-SMBUS	DEFAULT
0	Memory Space Indicator	RO	Reset to 0b to indicate it is a Memory BAR.	No	0
2:1	Memory Map Type	RO	00b: support 32-bit Memory Space. 10b: support 64-bit Memory Space.	No	00b
3	Prefetchable	RO	Reset to 0b to indicate NT Port Configuration registers maps to Non-Prefetchable Memory Space.	No	0
19:4	Reserved	RsvdP	Not Support.	No	0-0h
31:20	Base Address 2	RW	Base Address 2.	No/Yes	000h

#### 8.4.13 BAR 3 REGISTER – OFFSET 1Ch

BIT	FUNCTION	TYPE	DESCRIPTION	EEPROM/ I2C-SMBUS	DEFAULT
0	Memory Space Indicator	RO	When 18h[2:1]=00b, BAR 3 is used as an independent 32-bit BAR.	No	0
		RW	When 18h[2:1]=10b, BAR 3 is used as the upper 32 bits of 64-bit BAR 2/3.	No/Yes	0
2:1	Memory Map Type	RO	When 18h[2:1]=00b, BAR 3 is used as an independent 32-bit BAR.	No	00b
		RW	When 18h[2:1]=10b, BAR 3 is used as the upper 32 bits of 64-bit BAR 2/3.	No/Yes	00b

BIT	FUNCTION	TYPE	DESCRIPTION	EEPROM/ I2C-SMBUS	DEFAULT
3	Prefetchable	RO	When 18h[2:1]=00b, BAR 3 is used as an independent 32-bit BAR.	No	0
		RW	When 18h[2:1]=10b, BAR 3 is used as the upper 32 bits of 64-bit BAR 2/3.	No/Yes	0
31:4	Base Address 3	RsvdP	When 18h[2:1]=00b, BAR 3 is used as an independent 32-bit BAR.	No	0000_000h
		RW	When 18h[2:1]=10b, BAR 3 is used as the upper 32 bits of 64-bit BAR 2/3.	No/Yes	0000_000h

#### 8.4.14 BAR 4 REGISTER – OFFSET 20h

BIT	FUNCTION	TYPE	DESCRIPTION	EEPROM/ I2C-SMBUS	DEFAULT
0	Memory Space Indicator	RO	Reset to 0b to indicate it is a Memory BAR.	No	0
2:1	Memory Map Type	RO	00b: support 32-bit Memory Space 10b: support 64-bit Memory Space	No	00b
3	Prefetchable	RO	Reset to 0b to indicate NT Port Configuration registers maps to Non-Prefetchable Memory Space.	No	0
19:4	Reserved	RsvdP	Not Support.	No	0-0h
31:20	Base Address 4	RW	Base Address 4.	No/Yes	000h

#### 8.4.15 BAR 5 REGISTER – OFFSET 24h

BIT	FUNCTION	TYPE	DESCRIPTION	EEPROM/ I2C-SMBUS	DEFAULT
0	Memory Space Indicator	RO	When 20h[2:1]=00b, BAR 5 is used as an independent 32-bit BAR.	No	0
		RW	When 20h[2:1]=10b, BAR 5 is used as the upper 32 bits of 64-bit BAR 4/5.	No/Yes	0
2:1	Memory Map Type	RO	When 20h[2:1]=00b, BAR 5 is used as an independent 32-bit BAR.	No	00b
		RW	When 20h[2:1]=10b, BAR 5 is used as the upper 32 bits of 64-bit BAR 4/5.	No/Yes	00b
3	Prefetchable	RO	When 20h[2:1]=00b, BAR 5 is used as an independent 32-bit BAR.	No	0
		RW	When 20h[2:1]=10b, BAR 5 is used as the upper 32 bits of 64-bit BAR 4/5.	No/Yes	0
31:4	Base Address 3	RsvdP	When 20h[2:1]=00b, BAR 5 is used as an independent 32-bit BAR.	No	0000_000h
		RW	When 20h[2:1]=10b, BAR 5 is used as the upper 32 bits of 64-bit BAR 4/5.	No/Yes	0000_000h

#### 8.4.16 SUBSYSTEM VENDOR ID REGISTER – OFFSET 2Ch

BIT	FUNCTION	TYPE	DESCRIPTION	EEPROM/ I2C-SMBUS	DEFAULT
15:0	SSVID	RO	It indicates the sub-system vendor id.	No/Yes	12D8h

#### 8.4.17 SUBSYSTEM ID REGISTER – OFFSET 2Ch

BIT	FUNCTION	TYPE	DESCRIPTION	EEPROM/ I2C-SMBUS	DEFAULT
31:16	SSID	RO	It indicates the sub-system device id.	No/Yes	8608h

#### 8.4.18 CAPABILITY POINTER REGISTER – OFFSET 34h

BIT	FUNCTION	TYPE	DESCRIPTION	EEPROM/ I2C-SMBUS	DEFAULT
7:0	Capability Pointer	RO	Indicates next capability pointer.	Yes	40h

#### 8.4.19 INTERRUPT LINE REGISTER – OFFSET 3Ch

BIT	FUNCTION	TYPE	DESCRIPTION	EEPROM/ I2C-SMBUS	DEFAULT
7:0	Interrupt Line	RW	Indicates Interrupt Line.	No/Yes	00h

#### 8.4.20 INTERRUPT PIN REGISTER – OFFSET 3Ch

BIT	FUNCTION	TYPE	DESCRIPTION	EEPROM/ I2C-SMBUS	DEFAULT
15:8	Interrupt Pin	RO	The Switch implements INTA virtual wire interrupt signal. Only 00h or 01h is valid.	Yes	01h

#### 8.4.21 POWER MANAGEMENT CAPABILITIES REGISTER – OFFSET 40h

BIT	FUNCTION	TYPE	DESCRIPTION	EEPROM/ I2C-SMBUS	DEFAULT
7:0	Enhanced Capabilities ID	RO	Read as 01h to indicate that these are power management enhanced capability registers.	No	01h
15:8	Next Item Pointer	RO	Indicates next capability pointer.	Yes	48h
18:16	Power Management Revision	RO	Read as 011b to indicate the device is compliant to Revision 1.2 of <i>PCI Power Management Interface Specifications</i> .	No	011b
19	PME# Clock	RsvdP	Not Support.	No	0
20	Reserved	RsvdP	Not Support.	No	0
21	Device Specific Initialization	RO	Read as 0b to indicate Switch does not have device specific initialization requirements.	Yes	0
24:22	AUX Current	RO	Reset to 000b.	Yes	000b
25	D1 Power State Support	RO	Read as 0b to indicate Switch does not support the D1 power management state.	Yes	0
26	D2 Power State Support	RO	Read as 0b to indicate Switch does not support the D2 power management state.	Yes	0
31:27	PME# Support	RO	Read as 19h to indicate Switch supports the forwarding of PME# message in D0, D3 and D4 states.	Yes	19h

#### 8.4.22 POWER MANAGEMENT DATA REGISTER – OFFSET 44h

BIT	FUNCTION	TYPE	DESCRIPTION	EEPROM/ I2C-SMBUS	DEFAULT
1:0	Power State	RW	Indicates the current power state of the Switch. Writing a value of D0 when the previous state was D3 cause a hot reset without asserting DWRST_L.  00b: D0 state 01b: D1 state 10b: D2 state 11b: D3 hot state	No/Yes	00b
2	Reserved	RsvdP	Not Support.	No	0

BIT	FUNCTION	TYPE	DESCRIPTION	EEPROM/ I2C-SMBUS	DEFAULT
3	No_Soft_Reset	RO	When set, this bit indicates that device transitioning from D3hot to D0 does not perform an internal reset. When clear, an internal reset is performed when power state transits from D3hot to D0.	Yes	1
7:4	Reserved	RsvdP	Not Support.	No	0h
8	PME# Enable	RW	When asserted, the Switch will generate the PME# message.	No/Yes	0
12:9	Data Select	RO	Select data registers.	No/Yes	0h
14:13	Data Scale	RO	Reset to 00b.	No	00b
15	PME Status	RO	Read as 0b as the PME# message is not implemented.	No	0

#### 8.4.23 PPB SUPPORT EXTENSIONS – OFFSET 44h

BIT	FUNCTION	TYPE	DESCRIPTION	EEPROM/ I2C-SMBUS	DEFAULT
21:16	Reserved	RsvdP	Not Support.	No	00_0000b
22	B2_B3 Support for D3 <sub>HOT</sub>	RO	Does not apply to PCI Express. Must be hardwired to 0.	No	0
23	Bus Power / Clock Control Enable	RO	Does not apply to PCI Express. Must be hardwired to 0.	No	0

#### 8.4.24 DATA REGISTER – OFFSET 44h

BIT	FUNCTION	TYPE	DESCRIPTION	EEPROM/ I2C-SMBUS	DEFAULT
31:24	Data Register	RO	Data Register.	Yes	00h

#### 8.4.25 MSI CAPABILITIES REGISTER – OFFSET 48h

BIT	FUNCTION	TYPE	DESCRIPTION	EEPROM/ I2C-SMBUS	DEFAULT
7:0	Enhanced Capabilities ID	RO	Read as 05h to indicate that this is message signal interrupt capability register.	No	05h
15:8	Next Item Pointer	RO	Indicates next capability pointer.	Yes	68h
16	MSI Enable	RW	0b: The function is prohibited from using MSI to request service 1b: The function is permitted to use MSI to request service and is prohibited from using its INTx # pin	No/Yes	0
19:17	Multiple Message Capable	RO	Do not support multiple messages.	No	000b
22:20	Multiple Message Enable	RW	Reset to 000b.	No/Yes	000b
23	64-bit address capable	RO	0b: The function is not capable of generating a 64-bit message address 1b: The function is capable of generating a 64-bit message address	No	1b
31:24	Reserved	RsvdP	Not Support.	No	00h

#### 8.4.26 MESSAGE ADDRESS REGISTER – OFFSET 4Ch

BIT	FUNCTION	TYPE	DESCRIPTION	EEPROM/ I2C-SMBUS	DEFAULT
1:0	Reserved	RsvdP	Not Support.	No	00b
31:2	Message Address	RW	If the message enable bit is set, the contents of this register specify the DWORD aligned address for MSI memory write transaction.	No/Yes	0-0h

### 8.4.27 MESSAGE UPPER ADDRESS REGISTER – OFFSET 50h

BIT	FUNCTION	TYPE	DESCRIPTION	EEPROM/ I2C-SMBUS	DEFAULT
31:0	Message Upper Address	RW	This register is only effective if the device supports a 64-bit message address is set.	No/Yes	0000_0000h

### 8.4.28 MESSAGE DATA REGISTER – OFFSET 54h

BIT	FUNCTION	TYPE	DESCRIPTION	EEPROM/ I2C-SMBUS	DEFAULT
15:0	Message Data	RW	Message data.	No/Yes	0000h
31:16	Reserved	RsvdP	Not Support.	No	0000h

### 8.4.29 PCI EXPRESS CAPABILITIES REGISTER – OFFSET 68h

BIT	FUNCTION	TYPE	DESCRIPTION	EEPROM/ I2C-SMBUS	DEFAULT
7:0	Enhanced Capabilities ID	RO	Read as 10h to indicate that these are PCI express enhanced capability registers.	No	10h
15:8	Next Item Pointer	RO	Indicates next capability pointer.	Yes	A4h
19:16	Capability Version	RO	Read as 2h to indicate the device is compliant to Revision .2.0 of <i>PCI Express Base Specifications</i> .	No	2h
23:20	Device/Port Type	RO	Indicates the type of PCI Express logical device.	No	0h
24	Slot Implemented	RO	Reset to 0b.	No	0
29:25	Interrupt Message Number	RO	Read as 0. No MSI messages are generated in the transparent mode.	No	00_000b
31:30	Reserved	RsvdP	Not Support.	No	00b

### 8.4.30 DEVICE CAPABILITIES REGISTER – OFFSET 6Ch

BIT	FUNCTION	TYPE	DESCRIPTION	EEPROM/ I2C-SMBUS	DEFAULT
2:0	Max_Payload_Size Supported	RO	Indicates the maximum payload size that the device can support for TLPs.  000b: 128 payload size 001b: 256 payload size 010b: 512 payload size	Yes	001b
4:3	Phantom Functions Supported	RO	Indicates the support for use of unclaimed function numbers as Phantom functions. Read as 0, since the Switch does not act as a requester.	No	00b
5	Extended Tag Field Supported	RO	Indicates the maximum supported size of Tag field as a Requester. Read as 0, since the Switch does not act as a requester.	No	0
8:6	Endpoint L0s Acceptable Latency	RO	Acceptable total latency that an Endpoint can withstand due to the transition from L0s state to the L0 state. For Switch, the ASPM software would not check this value.	No	111b
11:9	Endpoint L1 Acceptable Latency	RO	Acceptable total latency that an Endpoint can withstand due to the transition from L1 state to the L0 state. For Switch, the ASPM software would not check this value.	No	111b
14:12	Reserved	RsvdP	Not Support.	No	000b
15	Role_Based Error Reporting	RO	When set, indicates that the device implements the functionality originally defined in the Error Reporting ECN.	Yes	1
17:16	Reserved	RsvdP	Not Support.	No	00b
25:18	Captured Slot Power Limit Value	RO	These bits are hardwired to 0.	No	00h
27:26	Captured Slot Power Limit Scale	RO	These bits are hardwired to 0.	No	00b

BIT	FUNCTION	TYPE	DESCRIPTION	EEPROM/ I2C-SMBUS	DEFAULT
31:28	Reserved	RsvdP	Not Support.	No	0h

#### 8.4.31 DEVICE CONTROL REGISTER – OFFSET 70h

BIT	FUNCTION	TYPE	DESCRIPTION	EEPROM/ I2C-SMBUS	DEFAULT
0	Correctable Error Reporting Enable	RW	0b: Disable Correctable Error Reporting 1b: Enable Correctable Error Reporting	No/Yes	0
1	Non-Fatal Error Reporting Enable	RW	0b: Disable Non-Fatal Error Reporting 1b: Enable Non-Fatal Error Reporting	No/Yes	0
2	Fatal Error Reporting Enable	RW	0b: Disable Fatal Error Reporting 1b: Enable Fatal Error Reporting	No/Yes	0
3	Unsupported Request Reporting Enable	RW	0b: Disable Unsupported Request Reporting 1b: Enable Unsupported Request Reporting	No/Yes	0
4	Enable Relaxed Ordering	RO	When set, it permits the device to set the Relaxed Ordering bit in the attribute field of transaction. Since the Switch can not either act as a requester or alter the content of packet it forwards, this bit always returns '0' when read.	No	0
7:5	Max_Payload_Size	RW	This field sets maximum TLP payload size for the device. Permissible values that can be programmed are indicated by the Max_Payload_Size Supported in the Device Capabilities register. Any value exceeding the Max_Payload_Size Supported written to this register results into clamping to the Max_Payload_Size Supported value.	No/Yes	000b
8	Extended Tag Field Enable	RsvdP	Not Support.	No	0
9	Phantom Function Enable	RsvdP	Not Support.	No	0
10	Auxiliary (AUX) Power PM Enable	RsvdP	Not Support.	No	0
11	Enable No Snoop	RsvdP	Not Support.	No	0
14:12	Max_Read_Request_Size	RO	This field sets the maximum Read Request size for the device as a Requester. Since the Switch does not generate read request by itself, these bits are hardwired to 0.	No	000b
15	Reserved	RsvdP	Not Support.	No/No	0

#### 8.4.32 DEVICE STATUS REGISTER – OFFSET 70h

BIT	FUNCTION	TYPE	DESCRIPTION	EEPROM/ I2C-SMBUS	DEFAULT
16	Correctable Error Detected	RWIC	Asserted when correctable error is detected. Errors are logged in this register regardless of whether error reporting is enabled or not in the Device Control register.	No/Yes	0
17	Non-Fatal Error Detected	RWIC	Asserted when non-fatal error is detected. Errors are logged in this register regardless of whether error reporting is enabled or not in the Device Control register.	No/Yes	0
18	Fatal Error Detected	RWIC	Asserted when fatal error is detected. Errors are logged in this register regardless of whether error reporting is enabled or not in the Device Control register.	No/Yes	0
19	Unsupported Request Detected	RWIC	Asserted when unsupported request is detected. Errors are logged in this register regardless of whether error reporting is enabled or not in the Device Control register.	No/Yes	0
20	AUX Power Detected	RO	Asserted when the AUX power is detected by the Switch	No	0
21	Transactions Pending	RO	Each port of Switch does not issue Non-posted Requests on its own behalf, so this bit is hardwired to 0.	No	0
31:22	Reserved	RsvdP	Not Support.	No	0-0h

### 8.4.33 LINK CAPABILITIES REGISTER – OFFSET 74h

BIT	FUNCTION	TYPE	DESCRIPTION	EEPROM/ I2C-SMBUS	DEFAULT
3:0	Maximum Link Speed	RO	Indicates the maximum speed of the Express link. 0001b: link is 2.5 Gb/s 0010b: link is 5Gb/s Others: Reserved	No	2h
9:4	Maximum Link Width	HWInt RO	Indicates the maximum width of the given PCIe Link. 00_0001b: x1 link 00_0100b: x4 link Others: Reserved	No	01h or 04h
11:10	Active State Power Management (ASPM) Support	RO	Indicates the level of ASPM supported on the given PCIe Link. Each port of Switch supports L0s and L1 entry.	Yes	01b
14:12	L0s Exit Latency	RO	Indicates the L0s exit latency for the given PCIe Link. The length of time this port requires to complete transition from L0s to L0 is in the range of 256ns to less than 512ns.	Yes	011b
17:15	L1 Exit Latency	RO	Indicates the L1 exit latency for the given PCIe Link. The length of time this port requires to complete transition from L1 to L0 is less than 1us.	Yes	000b
18	Clock Power Management	RO	This bit must be hardwired to 0.	Yes	1
19	Surprise Down Capability Enable	RsvdP	Not Support.	No	0
20	Data Link Layer Active Reporting Capable	RsvdP	Not Support.	No	0
21	Link BW Notify Capability	RsvdP	Not Support.	No	0
23:20	Reserved	RsvdP	Not Support.	No	0-0h
31:24	Port Number	RO	Indicates the NT-Port Number.	Yes	00h... Port 0 01h... Port 1 ...

### 8.4.34 LINK CONTROL REGISTER – OFFSET 78h

BIT	FUNCTION	TYPE	DESCRIPTION	EEPROM/ I2C-SMBUS	DEFAULT
1:0	Active State Power Management (ASPM) Control	RW	00b: ASPM is Disabled 01b: L0s Entry Enabled 10b: L1 Entry Enabled 11b: L0s and L1 Entry Enabled  Note that the receiver must be capable of entering L0s even when the field is disabled	No/Yes	00b
2	Reserved	RsvdP	Not Support.	No	0
3	Read Completion Boundary (RCB)	RO	Does not apply to PCI Express Switch. Returns '0' when read.	No	0
4	Link Disable	RsvdP	Not Support.	No	0
5	Retrain Link	RsvdP	Not Support.	No	0
6	Common Clock Configuration	RW	0b: The components at both ends of a link are operating with synchronous reference clock. 1b: The components at both ends of a link are operating with a distributed common reference clock	No/Yes	0
7	Extended Synch	RW	When set, it transmits 4096 FTS ordered sets in the L0s state for entering L0 state and transmits 1024 TS1 ordered sets in the L1 state for entering L0 state.	No/Yes	0
8	Enable Clock Power Management	RsvdP	Not Support.	No/Yes	0



BIT	FUNCTION	TYPE	DESCRIPTION	EEPROM/ I2C-SMBUS	DEFAULT
9	HW Autonomous Width Disable	RW	Reset to 0b.	No/Yes	0
10	Link Bandwidth Management Interrupt Enable	RW	Reset to 0b.	No/Yes	0
11	Link Autonomous Bandwidth Interrupt Enable	RW	Reset to 0b.	No/Yes	0
15:12	Reserved	RsvdP	Not Support.	No	00h

#### 8.4.35 LINK STATUS REGISTER – OFFSET 78h

BIT	FUNCTION	TYPE	DESCRIPTION	EEPROM/ I2C-SMBUS	DEFAULT
19:16	Link Speed	RO	Indicate the negotiated speed of the Express link. 0001b: link is 2.5 Gb/s 0010b: link is 5.0 Gb/s	No	1h
25:20	Negotiated Link Width	RO	Indicates the negotiated width of the given PCIe link. 00_0001b: x1 link 00_0010b: x2 link 00_0100b: x4 link	No	00_0001b
26	Training Error	RsvdP	Not Support.	No	0
27	Link Training	RsvdP	Not Support.	No	0
28	Slot Clock Configuration	RO	0b: the Switch uses an independent clock corresponsive of the presence of a reference on the connector 1b: the Switch uses the same reference clock that the platform provides on the connector	Yes	1
29	Data Link Layer Link Active	RsvdP	Not Support.	No	0
30	Link Bandwidth Management Status	RO	Reset to 0b.	No	0
31	Link Autonomous Bandwidth Status	RO	Reset to 0b.	No	0

#### 8.4.36 LINK CONTROL REGISTER 2 – OFFSET 98h

BIT	FUNCTION	TYPE	DESCRIPTION	EEPROM/ I2C-SMBUS	DEFAULT
3:0	Target Link Speed	RW	Not Support.	No/Yes	2h
4	Enter Compliance	RW	Not Support.	No/Yes	0
5	Hardware Autonomous Speed Disable	RW	Not Support.	No/Yes	0
6	Selectable De-Emphasis	RsvdP	Not Support.	No	0
9:7	Tran_Margin	RW	Not Support.	No/Yes	000b
10	Enter Modify Compliance	RW	Not Support.	No/Yes	0
11	Compliance SOS	RW	Not Support.	No/Yes	0
12	Compliance Deemp	RW	Not Support.	No/Yes	0
15:13	Reserved	RsvdP	Not Support.	No	000b

#### 8.4.37 LINK STATUS REGISTER 2 – OFFSET 98h

BIT	FUNCTION	TYPE	DESCRIPTION	EEPROM/ I2C-SMBUS	DEFAULT
16	Current De-emphasis level	RO	0b: -6dB 1b: -3.5dB	No	0
31:17	Link status 2	RO	Not Support.	No	0-0h

#### 8.4.38 SSID/SSVID CAPABILITIES REGISTER – OFFSET A4h

BIT	FUNCTION	TYPE	DESCRIPTION	EEPROM/ I2C-SMBUS	DEFAULT
7:0	SSID/SSVID Capabilities ID	RO	Read as 0D to indicate that these are SSID/SSVID capability registers.	No	0Dh
15:8	Next Item Pointer	RO	Indicates next capability pointer.	Yes	C8h
31:16	Reserved	RsvdP	Not Support.	No	0000h

#### 8.4.39 SUBSYSTEM VENDOR ID REGISTER – OFFSET A8h

BIT	FUNCTION	TYPE	DESCRIPTION	EEPROM/ I2C-SMBUS	DEFAULT
15:0	SSVID	RO	It indicates the sub-system vendor id.	Yes	12D8h

#### 8.4.40 SUBSYSTEM ID REGISTER – OFFSET A8h

BIT	FUNCTION	TYPE	DESCRIPTION	EEPROM/ I2C-SMBUS	DEFAULT
31:16	SSID	RO	It indicates the sub-system device id.	Yes	8608h

#### 8.4.41 VENDOR SPECIFIC CAPABILITIES REGISTER – OFFSET C8h

BIT	FUNCTION	TYPE	DESCRIPTION	EEPROM/ I2C-SMBUS	DEFAULT
7:0	Enhanced Capabilities ID	RO	Read as 09h to indicate that these are vendor specific capability registers.	No	09h
15:8	Next Item Pointer	RO	Read as 00h. No other ECP registers.	No	00h
31:16	Length Information	RO	The length field provides the information for number of bytes in the capability structure.	No	0038h

#### 8.4.42 VENDOR SPECIFIC HEADER REGISTER – OFFSET CCh

BIT	FUNCTION	TYPE	DESCRIPTION	EEPROM/ I2C-SMBUS	DEFAULT
31:0	Reserved	RsvdP	Reset to 0380_0002h.	No	0380_0002h

#### 8.4.43 NT PORT VIRTUAL INTERFACE BAR 0-1 CONFIGURATION REGISTER – OFFSET D0h

BIT	FUNCTION	TYPE	DESCRIPTION	EEPROM/ I2C-SMBUS	DEFAULT
1:0	BAR0 Type	RW	00b: Disable BAR0/1 01b: Reserved 10b: BAR0 is implemented as a 32 bit Memory BAR 11b: BAR0/1 is implemented as a 64-bit Memory BAR	Yes	10b
2	BAR0 Prefetchable	RW	0b: Non Prefetchable 1b: Prefetchable	Yes	0
31:3	Reserved	RsvdP	Not Support.	No	0-0h

#### 8.4.44 NT PORT VIRTUAL INTERFACE BAR 2 CONFIGURATION REGISTER – OFFSET D4h

BIT	FUNCTION	TYPE	DESCRIPTION	EEPROM/ I2C-SMBUS	DEFAULT
0	Type Selector	RsvdP	Not Support.	No	0
2:1	BAR2 Type	RW	00b: BAR2 is implemented as a 32 bit Memory BAR 10b: BAR2/3 is implemented as a 64-bit Memory BAR	No/Yes	00b
3	Prefetchable	RW	0b: Non Prefetchable 1b: Prefetchable	No/Yes	0
19:4	Reserved	RsvdP	Not Support.	No	0_000h
30:20	BAR2 Size	RW	To specify BAR2 size. 0b: Corresponding BAR2 bits are RO bits that always return 0 1b: Corresponding BAR2 bits are RW bits	No/Yes	0-0h
31	BAR 2 Enable	RW	Valid when bits[2:1]=00b. 0b: Disable BAR2 1b: Enable BAR2	No/Yes	0
	BAR 2 Size	RW	Includes with bits[30:20] when tis BAR is used as a 64-bit BAR (bits[2:1]=10b).		

#### 8.4.45 NT PORT VIRTUAL INTERFACE BAR 2-3 CONFIGURATION REGISTER – OFFSET D8h

BIT	FUNCTION	TYPE	DESCRIPTION	EEPROM/ I2C-SMBUS	DEFAULT
0	Type Selector	RsvdP	Not Support.	No	0
2:1	BAR3 Type	RO	00b: BAR3 is implemented as a 32-bit Memory BAR.	No	00b
3	Prefetchable	RW	0b: Non Prefetchable 1b: Prefetchable	No/Yes	0
19:4	Upper 32 Bits	RsvdP	Not Support when D4h[2:1]=00b.	No	0_000h
		RW	When D4h[2:1]=10b, BAR2/3 are used as a 64-bit BAR, bit[31:0] (including bit[19:4]) are used as the upper 32-bits.	No/Yes	0_000h
30:20	BAR3 Size	RW	To specify BAR3 size. 0b: Corresponding BAR3 bits are RO bits that always return 0 1b: Corresponding BAR3 bits are RW bits	No/Yes	000h
31	BAR 3 Enable	RW	Valid when D4h[2:1]=00b. 0b: Disable BAR3 1b: Enable BAR3	No/Yes	0
	64-Bit BAR	RW	Valid when D4h[2:1]=10b. 0b: BAR2/3 is disabled, all BAR2/3 bits read 0. 1b: BAR2/3 is enabled as a 64-bit BAR.		

### 8.4.46 NT PORT VIRTUAL INTERFACE BAR 4 CONFIGURATION REGISTER – OFFSET DCh

BIT	FUNCTION	TYPE	DESCRIPTION	EEPROM/ I2C-SMBUS	DEFAULT
0	Type Selector	RsvdP	Not Support.	No	0
2:1	BAR4 Type	RW	00b: BAR4 is implemented as a 32 bit Memory BAR 10b: BAR4/5 is implemented as a 64-bit Memory BAR	No/Yes	00b
3	Prefetchable	RW	0b: Non Prefetchable 1b: Prefetchable	No/Yes	0
19:4	Reserved	RsvdP	Not Support.	No	0_000h
30:20	BAR4 Size	RW	To specify BAR4 size. 0b: Corresponding BAR4 bits are RO bits that always return 0 1b: Corresponding BAR4 bits are RW bits	No/Yes	0-0h
31	BAR4 Enable	RW	Valid when bis[2:1]=00b. 0b: Disable BAR4 1b: Enable BAR4	No/Yes	0
	BAR 4 Size	RW	Includes with bits[30:20] when tis BAR is used as a 64-bit BAR (bits[2:1]=10b).		

### 8.4.47 NT PORT VIRTUAL INTERFACE BAR 4/5 CONFIGURATION REGISTER – OFFSET E0h

BIT	FUNCTION	TYPE	DESCRIPTION	EEPROM/ I2C-SMBUS	DEFAULT
0	Type Selector	RsvdP	Not Support.	No	0
2:1	BAR5 Type	RO	00b: BAR5 is implemented as a 32-bit Memory BAR.	No	00b
3	Prefetchable	RW	0b: Non Prefetchable 1b: Prefetchable	No/Yes	0
19:4	Upper 32 Bits	RsvdP	Not Support when DCh[2:1]=00b.	No	0_000h
		RW	When DCh[2:1]=10b, BAR4/5 are used as a 64-bit BAR, bit[31:0] (including bit[19:4]) are used as the upper 32-bits.	No/Yes	0_000h
30:20	BAR5 Size	RW	To specify BAR5 size. 0b: Corresponding BAR5 bits are RO bits that always return 0 1b: Corresponding BAR5 bits are RW bits	No/Yes	000h
31	BAR 5 Enable	RW	Valid when DCh[2:1]=00b. 0b: Disable BAR5. 1b: Enable BAR5.	No/Yes	0
	64-Bit BAR	RW	Valid when DCh[2:1]=10b. 0b: BAR4/5 is disabled, all BAR4/5 bits read 0. 1b: BAR4/5 is enabled as a 64-bit BAR.		

### 8.4.48 DEVICE SERIAL NUMBER ENHANCED CAPABILITY HEADER REGISTER – OFFSET 100h

BIT	FUNCTION	TYPE	DESCRIPTION	EEPROM/ I2C-SMBUS	DEFAULT
15:0	Extended Capabilities ID	RO	Read as 0003h to indicate that these are PCI express extended capability registers for device serial number extend capability register.	No	0003h
19:16	Capability Version	RO	Must be 1h for this version.	No	1h
31:20	Next Capability Offset	RO	Pointer points to the Advanced Error Reporting Extended Capability structure.	Yes	C34h

#### 8.4.49 DEVICE SERIAL NUMBER LOWER DW REGISTER – OFFSET 104h

BIT	FUNCTION	TYPE	DESCRIPTION	EEPROM/ I2C-SMBUS	DEFAULT
31:0	Device serial number 1 <sup>st</sup> DW	RO	First dword for device serial number.	Yes	0000_0000h

#### 8.4.50 DEVICE SERIAL NUMBER HIGHER DW REGISTER – OFFSET 108h

BIT	FUNCTION	TYPE	DESCRIPTION	EEPROM/ I2C-SMBUS	DEFAULT
31:0	Device serial number 2 <sup>nd</sup> DW	RO	Second dword for device serial number.	Yes	0000_0000h

#### 8.4.51 VENDOR SPECIFIC ENHANCED CAPABILITY HEADER REGISTER – OFFSET C34h

BIT	FUNCTION	TYPE	DESCRIPTION	EEPROM/ I2C-SMBUS	DEFAULT
15:0	Extended Capabilities ID	RO	Read as 000Bh to indicate that these are PCI express extended capability registers for vendor specific registers.	No	000Bh
19:16	Capability Version	RO	Read as 1h.	No	1h
31:20	Next Capability Offset	RO	Read as 000h. No other ECP registers.	No	000h

#### 8.4.52 VENDOR SPECIFIC HEADER REGISTER – OFFSET C38h

BIT	FUNCTION	TYPE	DESCRIPTION	EEPROM/ I2C-SMBUS	DEFAULT
31:0	Vendor Specific Header	RO	Reset to 0780_0003h.	No	0780_0003h

#### 8.4.53 MEMORY BAR 2 ADDRESS TRANSLATION REGISTER – OFFSET C3Ch

BIT	FUNCTION	TYPE	DESCRIPTION	EEPROM/ I2C-SMBUS	DEFAULT
19:0	Reserved	RsvdP	Not Support.	No	0_0000h
31:20	Memory BAR 2 Address Translation	RW	Valid when BAR 2 is enabled (offset E8h[31]=1).	Yes	000h

#### 8.4.54 MEMORY BAR 3 ADDRESS TRANSLATION REGISTER – OFFSET C40h

BIT	FUNCTION	TYPE	DESCRIPTION	EEPROM/ I2C-SMBUS	DEFAULT
19:0	Reserved	RsvdP	Not Support.	No	000h
31:20	Memory BAR 3 Address Translation	RW	Valid when BAR 3 is enabled (ECh[31]=1).	Yes	000h

#### 8.4.55 MEMORY BAR4 ADDRESS TRANSLATION REGISTER – OFFSET C44h

BIT	FUNCTION	TYPE	DESCRIPTION	EEPROM/ I2C-SMBUS	DEFAULT
19:0	Reserved	RsvdP	Not Support.	No	0_000h
31:20	Memory BAR 4 Address Translation	RW	Valid when BAR 4 is enabled (offset F0h[31]=1).	Yes	000h

#### 8.4.56 MEMORY BAR 5 ADDRESS TRANSLATION REGISTER – OFFSET C48h

BIT	FUNCTION	TYPE	DESCRIPTION	EEPROM/ I2C-SMBUS	DEFAULT
19:0	Reserved	RsvdP	Not Support.	No	000h
31:0	Memory BAR 5 Address Translation	RW	Valid when BAR 5 is enabled (F4h[31]=1).	Yes	000h

#### 8.4.57 VIRTUAL IF IRQ SET REGISTER – OFFSET C4Ch

BIT	FUNCTION	TYPE	DESCRIPTION	EEPROM/ I2C-SMBUS	DEFAULT
15:0	Set IRQ	RW	Set virtual interface IRQ.	No/Yes	0000h
31:16	Reserved	RsvdP	Not Support.	No	0000h

#### 8.4.58 VIRTUAL IF IRQ CLEAR REGISTER – OFFSET C50h

BIT	FUNCTION	TYPE	DESCRIPTION	EEPROM/ I2C-SMBUS	DEFAULT
15:0	Clear IRQ	RW1C	Clear virtual interface IRQ.	No/Yes	0000h
31:16	Reserved	RsvdP	Not Support.	No	0000h

#### 8.4.59 VIRTUAL IF IRQ MASK SET REGISTER – OFFSET C54h

BIT	FUNCTION	TYPE	DESCRIPTION	EEPROM/ I2C-SMBUS	DEFAULT
15:0	Set IRQ Mask	RW	Set virtual interface interrupt IRQ mask.	No/Yes	FFFFh
31:16	Reserved	RsvdP	Not Support.	No	0000h

#### 8.4.60 VIRTUAL IF IRQ MASK CLEAR REGISTER – OFFSET C58h

BIT	FUNCTION	TYPE	DESCRIPTION	EEPROM/ I2C-SMBUS	DEFAULT
15:0	Clear IRQ Mask	RW1C	Clear virtual interface interrupt IRQ mask.	No/Yes	FFFFh
31:16	Reserved	RsvdP	Not Support.	No	0000h

#### 8.4.61 LINK IF IRQ SET REGISTER – OFFSET C5Ch

BIT	FUNCTION	TYPE	DESCRIPTION	EEPROM/ I2C-SMBUS	DEFAULT
15:0	Set IRQ	RW	Set link interface IRQ.	No/Yes	0000h
31:16	Reserved	RsvdP	Not Support.	No	0000h

#### 8.4.62 LINK IF IRQ CLEAR REGISTER – OFFSET C60h

BIT	FUNCTION	TYPE	DESCRIPTION	EEPROM/ I2C-SMBUS	DEFAULT
15:0	Clear IRQ	RW1C	Clear link interface IRQ.	No/Yes	0000h
31:16	Reserved	RsvdP	Not Support.	No	0000h

#### 8.4.63 LINK IF IRQ MASK SET REGISTER – OFFSET C64h

BIT	FUNCTION	TYPE	DESCRIPTION	EEPROM/ I2C-SMBUS	DEFAULT
15:0	Set IRQ Mask	RW	Set link interface interrupt IRQ mask.	No/Yes	FFFFh
31:16	Reserved	RsvdP	Not Support.	No	0000h

#### 8.4.64 LINK IF IRQ MASK CLEAR REGISTER – OFFSET C68h

BIT	FUNCTION	TYPE	DESCRIPTION	EEPROM/ I2C-SMBUS	DEFAULT
15:0	Clear IRQ Mask	RW1C	Clear link interface interrupt IRQ mask.	No/Yes	FFFFh
31:16	Reserved	RsvdP	Not Support.	No	0000h

#### 8.4.65 SCRATCHPAD 0 REGISTER – OFFSET C6Ch

BIT	FUNCTION	TYPE	DESCRIPTION	EEPROM/ I2C-SMBUS	DEFAULT
31:0	Scratchpad 0	RW	Scratchpad 0 register.	No/Yes	0000_0000h

#### 8.4.66 SCRATCHPAD 1 REGISTER – OFFSET C70h

BIT	FUNCTION	TYPE	DESCRIPTION	EEPROM/ I2C-SMBUS	DEFAULT
31:0	Scratchpad 1	RW	Scratchpad 1 register.	No/Yes	0000_0000h

#### 8.4.67 SCRATHPAD 2 REGISTER – OFFSET C74h

BIT	FUNCTION	TYPE	DESCRIPTION	EEPROM/ I2C-SMBUS	DEFAULT
31:0	Scratchpad 2	RW	Scratchpad 2 register.	No/Yes	0000_0000h

#### 8.4.68 SCRATCHPAD 3 REGISTER – OFFSET C78h

BIT	FUNCTION	TYPE	DESCRIPTION	EEPROM/ I2C-SMBUS	DEFAULT
31:0	Scratchpad 3	RW	Scratchpad 3 register.	No/Yes	0000_0000h

#### 8.4.69 SCRATCHPAD 4 REGISTER – OFFSET C7Ch

BIT	FUNCTION	TYPE	DESCRIPTION	EEPROM/ I2C-SMBUS	DEFAULT
31:0	Scratchpad 4	RW	Scratchpad 4 register.	No/Yes	0000_0000h

#### 8.4.70 SCRATCHPAD 5 REGISTER – OFFSET C80h

BIT	FUNCTION	TYPE	DESCRIPTION	EEPROM/ I2C-SMBUS	DEFAULT
31:0	Scratchpad 5	RW	Scratchpad 5 register.	No/Yes	0000_0000h

#### 8.4.71 SCRATCHPAD 6 REGISTER – OFFSET C84h

BIT	FUNCTION	TYPE	DESCRIPTION	EEPROM/ I2C-SMBUS	DEFAULT
31:0	Scratchpad 6	RW	Scratchpad 6 register.	No/Yes	0000_0000h

#### 8.4.72 SCRATCHPAD 7 REGISTER – OFFSTE C88h

BIT	FUNCTION	TYPE	DESCRIPTION	EEPROM/ I2C-SMBUS	DEFAULT
31:0	Scratchpad 8	RW	Scratchpad 8 register.	No/Yes	0000_0000h

#### 8.4.73 VIRTUAL PORT 32-BITS LTT ENTRY 0-7 – OFFSET D94h to DB0h

**Table 8-10 Virtual Port 32-Bits LTT Entry 0-7 Register Locations**

CFG OFFSET	LTT Entry_n	CFG OFFSET	LTT Entry_n
D94h	0	DA4h	4
D98h	1	DA8h	5
D9Ch	2	DACH	6
DA0h	3	DB0h	7

**Table 8-11 Virtual Port 32-Bits LTT Entry\_n (n=0 through 7)**

BIT	FUNCTION	TYPE	DESCRIPTION	EEPROM/ I2C-SMBUS	DEFAULT
15:0	ReqID	RW	Bit[2:0]: function number Bit[7:3]: device number Bit[15:8]: bus number	No/Yes	0000h
29:16	Reserved	RsvdP	Not Support.	No	0-0h
30	LUT Entry_n No Snoop Enable	RsvdP	Not Support.	No	0
31	LUT Entry_n Enable	RW	0b: disable 1b: enable	No/Yes	0



#### 8.4.74 LINK PORT 16-BITS LTT ENTRY 0-31 REGISTER – OFFSET DB4h – DF4h

**Table 8-12 Link Port 16-Bits LTT Entry 0-31 Register Locations**

CFG OFFSET	LTT Entry_n	CFG OFFSET	LTT Entry_n
DB4h	0-1	DD4h	16-17
DB8h	2-3	DD8h	18-19
DBCh	4-5	DDCh	20-21
DC0h	6-7	DE0h	22-23
DC4h	8-9	DE4h	24-25
DC8h	10-11	DE8h	26-27
DCCh	12-13	DECh	28-29
DD0h	14-15	DF0h	30-31

**Table 8-13 Link Port 16-Bits LTT Entry\_n\_m (n\_m 0-1 to 30-31)**

BIT	FUNCTION	TYPE	DESCRIPTION	EEPROM/ I2C-SMBUS	DEFAULT
0	LUT Entry_n Enable	RW	0b: disable 1b: enable	No/Yes	0
1	LUT Entry_n No Snoop Enable	RsvdP	Not Support.	No	0
2	Reserved	RsvdP	Not Support.	No	0
15:3	ReqID	RW	Bit[7:3]: device number Bit[15:8]: device id	No/Yes	00h
16	LUT Entry_m Enable	RW	0b: disable 1b: enable	No/Yes	0
17	LUT Entry_m No Snoop Enable	RsvdP	Not Support.	No	0
18	Reserved	RsvdP	Not Support.	No	0
31:19	ReqID	RW	Bit[7:3]: device number Bit[15:8]: device id	No/Yes	00h

#### 8.4.75 FAIL-OVER CSR REGISTER – OFFSET DF4h

BIT	FUNCTION	TYPE	DESCRIPTION	EEPROM/ I2C-SMBUS	DEFAULT
0	Pri Linksdwn Force	RW	Test used only.	Yes	0
1	2nd Linksdwn Force	RW	Test used only.	Yes	0
2	Failover Enable	RW	Test used only.	Yes	0
3	Disable Hot Reset	RW	Test used only.	Yes	0
31:4	Reserved	RsvdP	Not Support.	No	0-0h

## 9 CLOCK SCHEME

The PI7C9X2G808PR requires 100MHz differential clock inputs through REFCLKP and REFCLKN Pins as shown in the following table.

**Table 9-1 DC Electrical Characteristics**

Description	Symbol	Min	Typ	Max	Unit
Reference Clock Frequency*	$f_i$		100		MHz
Accuracy	$A_i$	-300		+300	ppm
Duty Cycle	$DC_i$	45		55	%
> 1.5 MHz to Nyquist RMS jitter after applying PCIe filter function	$T_{REFCLK-HF-RMS}$	-		3.1	ps RMS
10 kHz - 1.5 MHz RMS jitter	$T_{REFCLK-LF-RMS}$	-		3.0	ps RMS
Spread Spectrum Clock frequency	$SS_{freq}$	30		33	kHz

\* Does not include  $\pm 300$ ppm. Only certain clock frequencies will produce valid PCI Express data.

## 10 POWER MANAGEMENT

The PI7C9X2G808PR supports D0, D1, D2, D3-hot, and D3-cold Power States. The PCI Express Physical Link Layer of the PI7C9X2G808PR device supports the PCI Express Link Power Management with L0, L0s, L1, L2/L3 ready and L3 Power States.

PI7C9X2G808PR also supports ASPM (Active State Power Management) to facilitate the link power saving.

## 11 POWER SEQUENCE

As long as PERST# is active, all PCI Express functions are held in reset. The main supplies ramp up to their specified levels (2.5V). Sometime during this stabilization time, the REFCLK starts and stabilizes. After there has been time (100 ms) for the power and clock to become stable, PERST# is deasserted high and the PCI Express functions can start up.

It is recommended to power up the I/O voltage (2.5V) first and then the core voltage (1.0V) or power up I/O voltage and core voltage simultaneously.

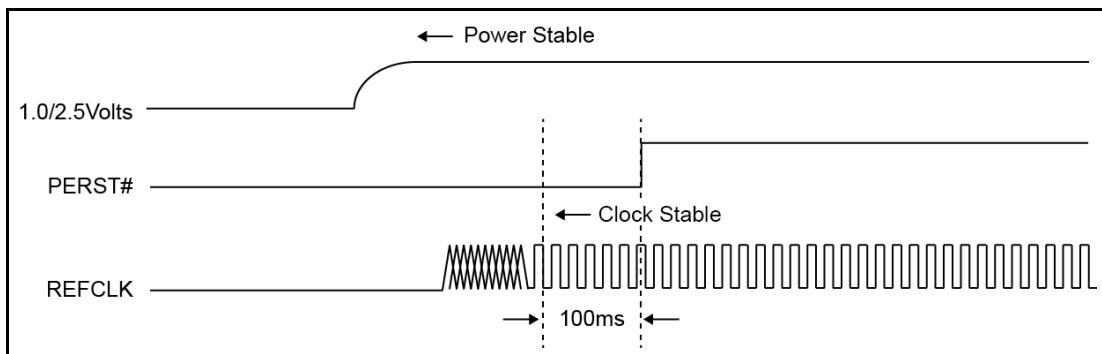

**Figure 11-1 Initial Power-Up Sequence**

Power-down sequence is the reverse of power-up sequence.

## 12 IEEE 1149.1 COMPATIBLE JTAG CONTROLLER

An IEEE 1149.1 compatible Test Access Port (TAP) controller and associated TAP pins are provided to support boundary scan in PI7C9X2G808PR for board-level continuity test and diagnostics. The TAP pins assigned are TCK, TDI, TDO, TMS and TRST\_L. All digital input, output, input/output pins are tested except TAP pins.

### 12.1 INSTRUCTION REGISTER

The IEEE 1149.1 Test Logic consists of a TAP controller, an instruction register, and a group of test data registers including Bypass and Boundary Scan registers. The TAP controller is a synchronous 16-state machine driven by the Test Clock (TCK) and the Test Mode Select (TMS) pins. An independent power on reset circuit is provided to ensure the machine is in TEST\_LOGIC\_RESET state at power-up.

PI7C9X2G808PR implements a 5-bit Instruction register to control the operation of the JTAG logic. The defined instruction codes are shown in the following table. Those bit combinations that are not listed are equivalent to the BYPASS (11111) instruction.

**Table 12-1 Instruction Register Codes**

Instruction	Operation Code (binary)	Register Selected	Operation
EXTEST	00000	Boundary Scan	Drives / receives off-chip test data
SAMPLE	00001	Boundary Scan	Samples inputs / pre-loads outputs
HIGHZ	00101	Bypass	Tri-states output and I/O pins except TDO pin
CLAMP	00100	Bypass	Drives pins from boundary-scan register and selects Bypass register for shifts
IDCODE	01100	Device ID	Accesses the Device ID register, to read manufacturer ID, part number, and version number
BYPASS	11111	Bypass	Selected Bypass Register
INT_SCAN	00010	Internal Scan	Scan test
MEM_BIST	01010	Memory BIST	Memory BIST test

### 12.2 BYPASS REGISTER

The required bypass register (one-bit shift register) provides the shortest path between TDI and TDO when a bypass instruction is in effect. This allows rapid movement of test data to and from other components on the board. This path can be selected when no test operation is being performed on the PI7C9X2G808PR.

### 12.3 DEVICE ID REGISTER

This register identifies Pericom as the manufacturer of the device and details the part number and revision number for the device.

**Table 12-2 JTAG Device ID Register**

Bit	Type	Value	Description
31-28	RO	0001	Version number
27-12	RO	0001011000010110	Last 4 digits (hex) of the die part number
11-1	RO	01000111111	Pericom identifier assigned by JEDEC
0	RO	1	Fixed bit equal to 1'b1

## 12.4 BOUNDARY SCAN REGISTER

The boundary scan register has a set of serial shift-register cells. A chain of boundary scan cells is formed by connected the internal signal of the PI7C9X2G808PR package pins. The VDD, VSS, and JTAG pins are not in the boundary scan chain. The input to the shift register is TDI and the output from the shift register is TDO. There are 4 different types of boundary scan cells, based on the function of each signal pin.

The boundary scan register cells are dedicated logic and do not have any system function. Data may be loaded into the boundary scan register master cells from the device input pins and output pin-drivers in parallel by the mandatory SAMPLE and EXTEST instructions. Parallel loading takes place on the rising edge of TCK.

## 12.5 JTAG BOUNDARY SCAN REGISTER ORDER

Table 12-3 JTAG Boundary Scan Register Definition

Boundary Scan Register Number	Pin Name	Ball Location	Type	Tri-state Control Cell
0			Internal	
1			Internal	
2			Internal	
3			Internal	
4			Internal	
5			Internal	
6			Internal	
7			Internal	
8	LNKSTS[6]	A14	Output3	9
9			Control	
10			Internal	
11			Internal	
12	FATAL_ERR_L	B13	Output3	13
13			Control	
14	LNKSTS[5]	B14	Output3	15
15			Control	
16	PORTCFG[0]	A1	Input	
17			Internal	
18	PORTCFG[1]	B2	Input	
19			Internal	
20			Internal	
21			Internal	
22			Internal	
23			Internal	
24			Internal	
25			Internal	
26			Internal	
27			Internal	
28	GPIO[30]	A2	Bidir	29
29			Control	
30			Internal	
31	LNKSTS[7]	C2	Output3	32
32			Control	
33	GPIO[29]	D3	Bidir	34
34			Control	
35	SERDES_MODE_EN_L	C4	Input	
36			Internal	
37			Internal	
38			Internal	
39	LNKSTS[4]	B1	Output3	40
40			Control	
41			Internal	

Boundary Scan Register Number	Pin Name	Ball Location	Type	Tri-state Control Cell
42			Internal	
43			Internal	
44			Internal	
45	FAST_MODE_L	C3	Input	
46			Internal	
47			Internal	
48			Internal	
49			Internal	
50			Internal	
51	GPIO[4]	E1	Birdir	52
52			Control	
53	GPIO[3]	E2	Birdir	54
54			Control	
55	GPIO[1]	D1	Birdir	56
56			Control	
57	UPS_PORTSEL[3]	G2	Input	
58			Internal	
59	UPS_PORTSEL[0]	F3	Input	
60			Internal	
61	GPIO[2]	E3	Birdir	62
62			Control	
63	GPIO[0]	D2	Birdir	64
64			Control	
65	UPS_PORTSEL[2]	H2	Input	
66			Internal	
67	UPS_PORTSEL[1]	F1	Input	
68			Internal	
69	GPIO[5]	F2	Birdir	70
70			Control	
71	NTPORT_SEL[0]	J3	Input	
72			Internal	
73			Internal	
74			Internal	
75	NTPORT_SEL[1]	J2	Input	
76			Internal	
77			Internal	
78			Internal	
79			Internal	
80			Internal	
81			Internal	
82			Internal	
83	GPIO[8]	H1	Birdir	84
84			Control	
85	GPIO[9]	K1	Birdir	86
86			Control	
87	NTPORT_SEL[2]	K3	Input	
88			Internal	
89			Internal	
90			Internal	
91			Internal	
92			Internal	
93			Internal	
94			Internal	
95	GPIO[7]	J1	Birdir	96
96			Control	
97			Internal	
98			Internal	
99			Internal	
100			Internal	
101			Internal	
102			Internal	
103			Internal	
104			Internal	

Boundary Scan Register Number	Pin Name	Ball Location	Type	Tri-state Control Cell
105			Internal	
106	GPIO[6]	J4	Bidir	107
107			Control	
108			Internal	
109			Internal	
110	GPIO[10]	M1	Bidir	111
111			Control	
112			Internal	
113			Internal	
114	DEBUG_SEL[1]	L2	Input	
115			Internal	
116	TEST	M4	Input	
117			Internal	
118	GPIO[13]	L3	Bidir	119
119			Control	
120	SMBUS_EN_L	L1	Input	
121			Internal	
122			Internal	
123			Internal	
124	GPIO[14]	M2	Bidir	125
125			Control	
126	CFG_TIMER_EN_L	C1	Input	
127			Internal	
128	NT_P2P_EN_L	G1	Input	
129			Internal	
130	GPIO[15]	N2	Bidir	131
131			Control	
132			Internal	
133	GPIO[11]	P2	Bidir	134
134			Control	
135			Internal	
136	GPIO[12]	P1	Bidir	137
137			Control	
138			Internal	
139	NTPORT_SEL[3]	M3	Input	
140			Internal	
141	TESTMODE[0]	P13	Input	
142			Internal	
143	TESTMODE[1]	N14	Input	
144			Internal	
145	TESTMODE[2]	M14	Input	
146			Internal	
147	TESTMODE[3]	N13	Input	
148			Internal	
149	LNKSTS[0]	P14	Output3	150
150			Control	
151	LNKSTS[1]	M13	Output3	152
152			Control	
153			Internal	
154			Internal	
155			Internal	
156			Internal	
157			Internal	
158			Internal	
159	GPIO[16]	K12	Bidir	160
160			Control	
161			Internal	
162			Internal	
163	LNKSTS[3]	L12	Output3	164
164			Control	
165			Internal	
166			Internal	
167			Internal	



Boundary Scan Register Number	Pin Name	Ball Location	Type	Tri-state Control Cell
168			Internal	
169			Internal	
170			Internal	
171	LNKSTS[2]	L14	Output3	172
172			Control	
173			Internal	
174			Internal	
175			Internal	
176			Internal	
177			Internal	
178			Internal	
179			Internal	
180			Internal	
181			Internal	
182			Internal	
183	PROBE_MODE_L	K13	Input	
184			Internal	
185			Internal	
186			Internal	
187			Internal	
188			Internal	
189			Internal	
190			Internal	
191			Internal	
192			Internal	
193	EECK	J14	Birdir	194
194			Control	
195	EECS_L	J13	Output3	196
196			Control	
197			Internal	
198			Internal	
199	PLL_BYPASS_L	M12	Input	
200			Internal	
201	INTA_L	J12	Output3	202
202			Control	
203	PERST_L	H13	Input	
204			Internal	
205			Internal	
206	NT_RESET_L	L13	Output3	207
207			Control	
208			Internal	
209			Internal	
210	NT_EN_L	H12	Input	
211			Internal	
212	DEBUG_SEL[0]	J11	Input	
213			Internal	
214	EEDO	H14	Input	
215			Internal	
216	EEDI	K14	Birdir	217
217			Control	
218	I2C_ADDR[2]	G14	Input	
219			Internal	
220	I2C_ADDR[1]	F11	Input	
221			Internal	
222			Internal	
223			Internal	
224			Internal	
225			Internal	
226			Internal	
227			Internal	
228			Internal	
229			Internal	
230			Internal	

Boundary Scan Register Number	Pin Name	Ball Location	Type	Tri-state Control Cell
231			Internal	
232			Internal	
233			Internal	
234			Internal	
235			Internal	
236	I2C_ADDR[0]	G13	Input	
237			Internal	
238	SCL_I2C	F14	Output3	239
239			Control	
240			Internal	
241			Internal	
242	SHDA_I2C	E14	Output3	243
243			Control	
244			Internal	
245			Internal	
246			Internal	
247			Internal	
248	SHCL_I2C	F13	Output3	249
249			Control	
250	SDA_I2C	F12	Output3	251
251			Control	
252	SHPCINT_L	C14	Input	
253			Internal	
254			Internal	
255			Internal	
256			Internal	
257			Internal	
258			Internal	
259			Internal	
260			Internal	
261			Internal	
262			Internal	

## 13 ELECTRICAL AND TIMING SPECIFICATIONS

### 13.1 ABSOLUTE MAXIMUM RATINGS

**Table 13-1 Absolute Maximum Ratings**

(Above which the useful life may be impaired. For user guidelines, not tested.)

Item	Absolute Max. Rating
Storage Temperature	-65°C to 150°C
Junction Temperature, T <sub>j</sub>	125°C
Digital core and analog supply voltage to ground potential (VDDC and AVDD)	-0.3v to 1.2v
Digital I/O and analog high supply voltage to ground potential (VDDR and AVDDH)	-0.3v to 3.8v
DC input voltage for Digital I/O signals	-0.3v to 3.8v
ESD Rating	
Human Body Model (JEDEC Class 2)	2kv
Charge Device Model (JEDEC Class 3)	500v

**Note:**

Stresses greater than those listed under MAXIMUM RATINGS may cause permanent damage to the device. This is a stress rating only and functional operation of the device at these or any conditions above those indicated in the operational sections of this specification is not implied. Exposure to absolute maximum rating conditions for extended periods of time may affect reliability.

### 13.2 DC SPECIFICATIONS

**Table 13-2 DC Electrical Characteristics**

Symbol	Description	Min.	Typ.	Max.	Unit	
VDDC	Digital Core Power	0.95	1.0	1.1	V	
VDDR	Digital I/O Power	2.25	2.5	2.75		
AVDD	PCI Express Analog Power	0.95	1.0	1.1		
AVDDH	PCI Express Analog High Voltage Power	2.25	2.5	2.75		
V <sub>IH</sub>	Input High Voltage	2.0		3.6		
V <sub>IL</sub>	Input Low Voltage	-0.3		0.8		
V <sub>OH</sub>	Output High Voltage	2.4	-	-		
V <sub>OL</sub>	Output Low Voltage	-	-	0.4		
R <sub>PU</sub>	Pull-up Resistor	63K	92K	142K		Ω
R <sub>PD</sub>	Pull-down Resistor	57K	91K	159K		
RST# <sub>Slew</sub> <sup>1</sup>	PERST_L Slew Rate	50			mV/ns	

**Note:**

1. The min. value for PERST\_L Slew Rate is 50 mV/ns, which translates to the requirement that the time for PERST\_L from 0V to 2.5V should be less than 50 ns.

### 13.3 AC SPECIFICATIONS

**Table 13-3 PCI Express Interface - Differential Transmitter (TX) Output (5.0 Gbps) Characteristics**

Parameter	Symbol	Min	Typ	Max	Unit
Unit Interval	UI	199.94	200.0	200.06	ps
Differential p-p TX voltage swing	V <sub>TX-DIFF-P-P</sub>	800	-	-	mV ppd
Low power differential p-p TX voltage swing	V <sub>TX-DIFF-P-P-LOW</sub>	400	-	-	mV ppd
TX de-emphasis level ratio	V <sub>TX-DE-RATIO-3.5dB</sub>	-3.0	-	-4.0	dB
TX de-emphasis level ratio	V <sub>TX-DE-RATIO-6dB</sub>	-5.5	-	-6.5	dB
Transmitter Eye including all jitter sources	T <sub>TX-EYE</sub>	0.75	-	-	UI

Parameter	Symbol	Min	Typ	Max	Unit
TX deterministic jitter > 1.5 MHz	$T_{TX-HF-DJ-DD}$	-	-	0.15	UI
TX RMS jitter < 1.5 MHz	$T_{TX-LF-RMS}$	-	-	3.0	Ps RMS
Transmitter rise and fall time	$T_{TX-RISE-FALL}$	0.15	-	-	UI
TX rise/fall mismatch	$T_{RF-MISMATCH}$	-	-	0.1	UI
Maximum TX PLL Bandwidth	$BW_{TX-PLL}$	-	-	16	MHz
Minimum TX PLL BW for 3dB peaking	$BW_{TX-PLL-L0-3DB}$	8	-	-	MHz
TX PLL peaking with 8 MHz min BW	$PKG_{TX-PLL1}$	-	-	3.0	dB
DC Differential TX Impedance	$Z_{TX-DIFF-DC}$	80	-	120	$\Omega$
Transmitter Short-Circuit Current Limit	$I_{TX-SHORT}$	-	-	90	mA
TX DC Common Mode Voltage	$V_{TX-DC-CM}$	0	-	3.6	V
Absolute Delta of DC Common Mode Voltage During L0 and Electrical Idle	$V_{TX-CM-DC-ACTIVE-IDLE-DELTA}$	0	-	100	mV
Absolute Delta of DC Common Mode Voltage between D+ and D-	$V_{TX-CM-DC-LINE-DELTA}$	0	-	25	mV
Electrical Idle Differential Peak Output Voltage	$V_{TX-IDLE-DIFF-AC-p}$	0	-	20	mV
DC Electrical Idle Differential Output Voltage	$V_{TX-IDLE-DIFF-DC}$	0	-	5	mV
The Amount of Voltage Change Allowed During Receiver Detection	$V_{TX-RCV-DETECT}$	-	-	600	mV
Lane-to-Lane Output Skew	$L_{TX-SKEW}$	-	-	500 ps + 4 UI	ps

Table 13-4 PCI Express Interface - Differential Transmitter (TX) Output (2.5 Gbps) Characteristics

Parameter	Symbol	Min	Typ	Max	Unit
Unit Interval	UI	399.88	400.0	400.12	ps
Differential p-p TX voltage swing	$V_{TX-DIFF-P-P}$	800	-	-	mV ppd
Low power differential p-p TX voltage swing	$V_{TX-DIFF-P-P-LOW}$	400	-	-	mV ppd
TX de-emphasis level ratio	$V_{TX-DE-RATIO}$	-3.0	-	-4.0	dB
Minimum TX eye width	$T_{TX-EYE}$	0.75	-	-	UI
Maximum time between the jitter median and max deviation from the median	$T_{TX-EYE-MEDIAN-to-MAX-JITTER}$	-	-	0.125	UI
Transmitter rise and fall time	$T_{TX-RISE-FALL}$	0.125	-	-	UI
Maximum TX PLL Bandwidth	$BW_{TX-PLL}$	-	-	22	MHz
Maximum TX PLL BW for 3dB peaking	$BW_{TX-PLL-L0-3DB}$	1.5	-	-	MHz
Absolute Delta of DC Common Mode Voltage During L0 and Electrical Idle	$V_{TX-CM-DC-ACTIVE-IDLE-DELTA}$	0	-	100	mV
Absolute Delta of DC Common Mode Voltage between D+ and D-	$V_{TX-CM-DC-LINE-DELTA}$	0	-	25	mV
Electrical Idle Differential Peak Output Voltage	$V_{TX-IDLE-DIFF-AC-p}$	0	-	20	mV
The Amount of Voltage Change Allowed During Receiver Detection	$V_{TX-RCV-DETECT}$	-	-	600	mV
Transmitter DC Common Mode Voltage	$V_{TX-DC-CM}$	0	-	3.6	V
Transmitter Short-Circuit Current Limit	$I_{TX-SHORT}$	-	-	90	mA
DC Differential TX Impedance	$Z_{TX-DIFF-DC}$	80	100	120	$\Omega$
Lane-to-Lane Output Skew	$L_{TX-SKEW}$	-	-	500 ps + 2 UI	ps

Table 13-5 PCI Express Interface - Differential Receiver (RX) Input (5.0 Gbps) Characteristics

Parameter	Symbol	Min	Typ	Max	Unit
Unit Interval	UI	199.94	200.0	200.06	ps
Differential RX Peak-to-Peak Voltage	$V_{RX-DIFF-PP-CC}$	120	-	1200	mV
Total jitter tolerance	$TJ_{RX}$	0.68	-	-	UI
Receiver DC common mode impedance	$Z_{RX-DC}$	40	-	60	$\Omega$
RX AC Common Mode Voltage	$V_{RX-CM-AC-P}$	-	-	150	mV
Electrical Idle Detect Threshold	$V_{RX-IDLE-DET-DIFF-p-p}$	65	-	175	mV

**Table 13-6 PCI Express Interface - Differential Receiver (RX) Input (2.5 Gbps) Characteristics**

Parameter	Symbol	Min	Typ	Max	Unit
Unit Interval	UI	399.88	400.0	400.12	ps
Differential RX Peak-to-Peak Voltage	$V_{RX-DIFF-PP-CC}$	175	-	1200	mV
Receiver eye time opening	$T_{RX-EYE}$	0.4	-	-	UI
Maximum time delta between median and deviation from median	$T_{RX-EYE-MEDIAN-to-MAX-JITTER}$	-	-	0.3	UI
Receiver DC common mode impedance	$Z_{RX-DC}$	40	-	60	$\Omega$
DC differential impedance	$Z_{RX-DIFF-DC}$	80	-	120	$\Omega$
RX AC Common Mode Voltage	$V_{RX-CM-AC-P}$	-	-	150	mV
DC input CM input impedance during reset or power down	$Z_{RX-HIGH-IMP-DC}$	200	-	-	k $\Omega$
Electrical Idle Detect Threshold	$V_{RX-IDLE-DET-DIFF-P}$	65	-	175	mV
Lane to Lane skew	$L_{RX-SKEW}$	-	-	20	ns

### 13.4 OPERATING AMBIENT TEMPERATURE

**Table 13-7 Operating Ambient Temperature**

(The Operating Ambient Temperature be associated with Chapter 14.)

Item	Low	High	Unit
Ambient Temperature with power applied	-40	85	$^{\circ}\text{C}$

**Note:** Exposure to high temperature conditions for extended periods of time may affect reliability.

### 13.5 POWER CONSUMPTION

**Table 13-8 Power Consumption**

Active Lane per Port	1.0VDDC		1.0VDDA		2.5AVDDH		2.5VDDR		Total		Unit
	Typ	Max	Typ	Max	Typ	Max	Typ	Max	Typ	Max	
8 x1	0.533	1.278	0.367	0.799	0.065	0.074	0.003	0.006	0.97	2.16	W
4 x4	0.641	1.125	0.520	0.800	0.068	0.074	0.005	0.006	1.23	2.01	W

**Test Conditions:**

- Typical power measured under the conditions of 1.0V/ 2.5V power rail without device usage on all downstream ports.
- Maximum power measured under the conditions of 1.1V/ 2.75V with PCIe2 devices usage on all downstream ports
- Ambient Temperature at 25 $^{\circ}\text{C}$
- Power consumption in the table is a reference, be affected by various environment, bus traffic and power supply etc.

## 14 THERMAL DATA

The information described in this section is provided for reference only.

**Table 14-1 Thermal Data**

Power (Watt)	T <sub>a</sub> (°C)	JEDEC Board	Airflow (m/s)	Θ <sub>JA</sub> (°C/W)	T <sub>i</sub> (°C)	Θ <sub>JC</sub> (°C/W)
1.96	85	4-Layer	0	26.65	137.23	8.96
			1	23.71	131.47	
			2	22.57	129.24	
		8-Layer	0	17.75	119.79	8.44
			1	16.65	117.63	
			2	16.33	117.01	

**Note:**

1. T<sub>a</sub>: Ambient Temperature
2. T<sub>i</sub>: Junction Temperature
3. Maximum allowable junction temperature = 125°C
4. Θ<sub>JA</sub>: Thermal Resistance, Junction-to-Ambient
5. Θ<sub>JC</sub>: Thermal Resistance, Junction-to-Case
6. Power measured under the conditions of 1.0V/ 2.5V with PCIe2 devices usage on all downstream ports in 808 mode
7. The shaded fields provide a recommendation that allows PI7C9X2G808PR to support Industrial Temperature Range

### 15 PACKAGE INFORMATION

The package of PI7C9X2G808PR is a 0.60mm Ball BGA (196 Ball) package. The following are the package information and mechanical dimension:

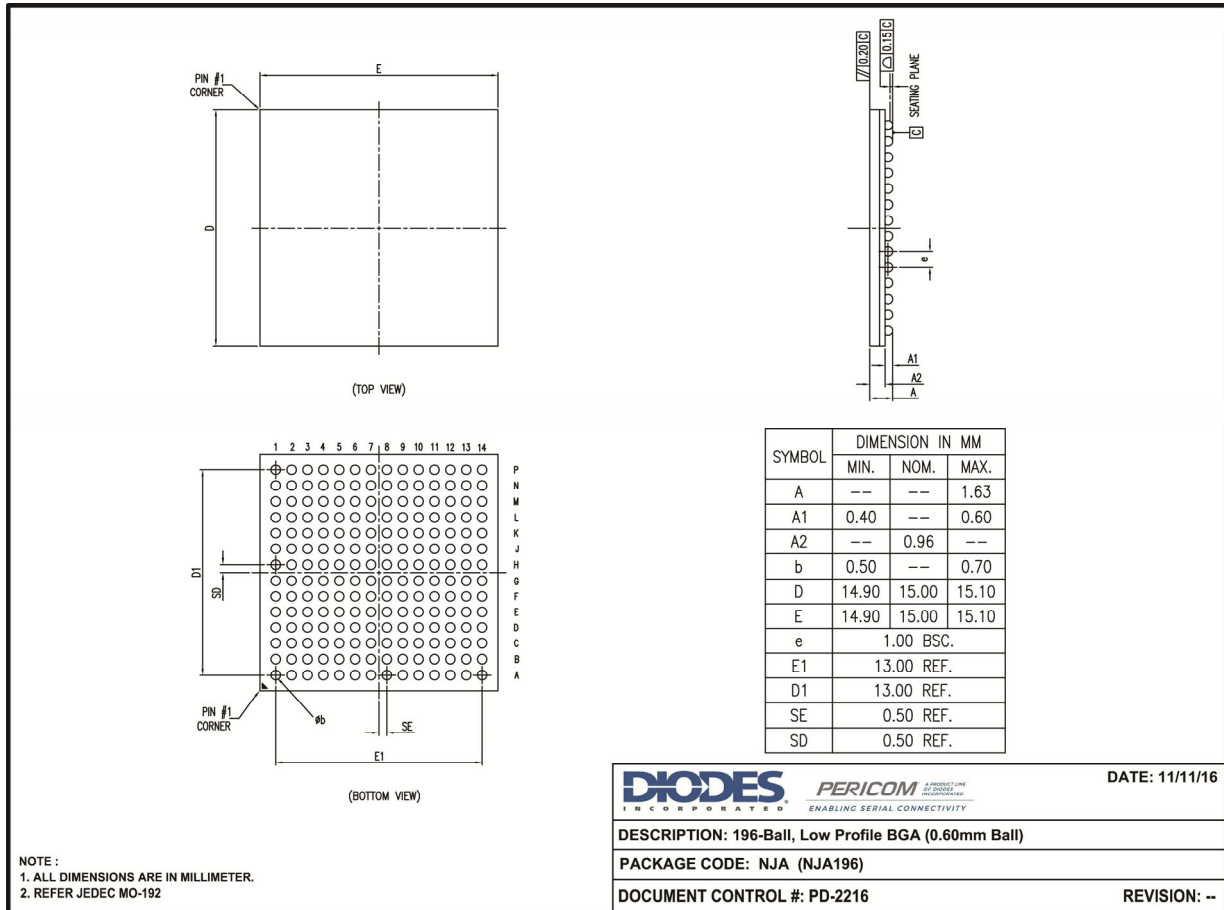

Figure 15-1 Package Outline Drawing

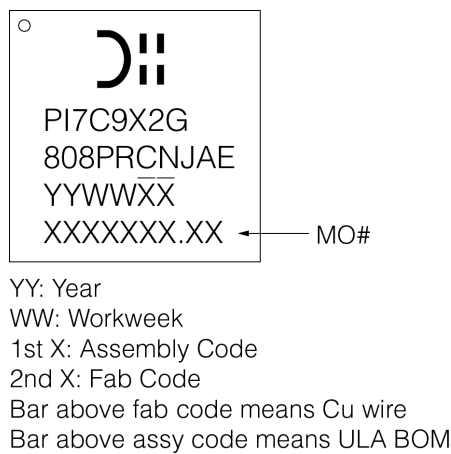

Figure 15-2 Part Marking

## 16 ORDERING INFORMATION

Part Number	Package Code	Package Description
PI7C9X2G808PRCNJAEX	NJA	196-Ball, Low Profile (BGA) 0.60mm Ball (ULA)

**Notes:**

1. No purposely added lead. Fully EU Directive 2002/95/EC (RoHS), 2011/65/EU (RoHS 2) & 2015/863/EU (RoHS 3) compliant.
2. See <https://www.diodes.com/quality/lead-free/> for more information about Diodes Incorporated's definitions of Halogen- and Antimony-free, "Green" and Lead-free.
3. Halogen- and Antimony-free "Green" products are defined as those which contain <900ppm bromine, <900ppm chlorine (<1500ppm total Br + Cl) and <1000ppm antimony compounds.

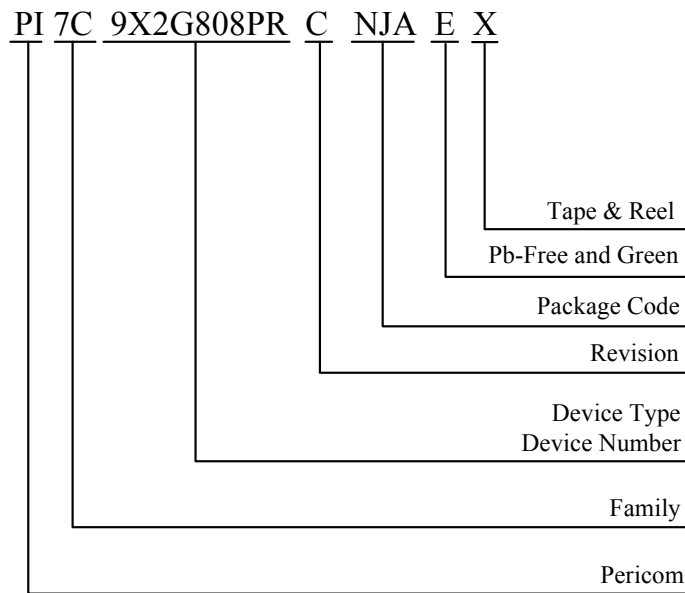



单击下面可查看定价，库存，交付和生命周期等信息

[>>Diodes Incorporated\(达达科技\(美台\)\)](#)