

Description

The AP4373A is an AC/DC secondary-side controller, which incorporates a decoder to translate Qualcomm QC2.0 protocol and transfer control signal to the primary side through opto-coupler.

The AP4373A can be used in Diodes Incorporated's primary-side controlled AC/DC systems to achieve fast voltage transition, low no-load power consumption and fast dynamic load response. When paired with Diodes Incorporated's primary-side controller AP3792, the AP4373A uses one opto-coupler to transfer all necessary information to the AP3792 including output voltage/current change requests, output dynamic response and abnormal condition protection signal.

The AP4373A integrates a safe-discharge circuitry to quickly and reliably discharge output capacitors when the output terminal is plugged out.

This IC is available in SOT25 package.

Applications

- AC/DC Adapters
- Battery Chargers

Pin Assignments

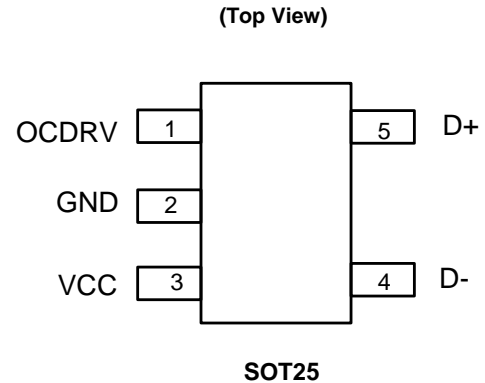

Features

- Support Qualcomm QC2.0 Protocol Combined with the AP3792 (QC2.0: 5V/9V)
- Low Standby Power
- Fast Dynamic Response
- Built in Opto Coupler LED Driver
- Output Capacitor Safe-Discharge Circuitry
- Fewest External Component Count
- Output Over Voltage Protection (OVP)
- D+/D- Over Voltage Protection
- **Totally Lead-Free & Fully RoHS Compliant (Notes 1 & 2)**
- **Halogen and Antimony Free. "Green" Device (Note 3)**
- **For automotive applications requiring specific change control (i.e. parts qualified to AEC-Q100/101/200, PPAP capable, and manufactured in IATF 16949 certified facilities), please [contact us](mailto:contact@diodes.com) or your local Diodes representative. <https://www.diodes.com/quality/product-definitions/>**

- Notes:
1. No purposely added lead. Fully EU Directive 2002/95/EC (RoHS), 2011/65/EU (RoHS 2) & 2015/863/EU (RoHS 3) compliant.
 2. See <https://www.diodes.com/quality/lead-free/> for more information about Diodes Incorporated's definitions of Halogen- and Antimony-free, "Green" and Lead-free.
 3. Halogen- and Antimony-free "Green" products are defined as those which contain <900ppm bromine, <900ppm chlorine (<1500ppm total Br + Cl) and <1000ppm antimony compounds.

Typical Applications Circuit

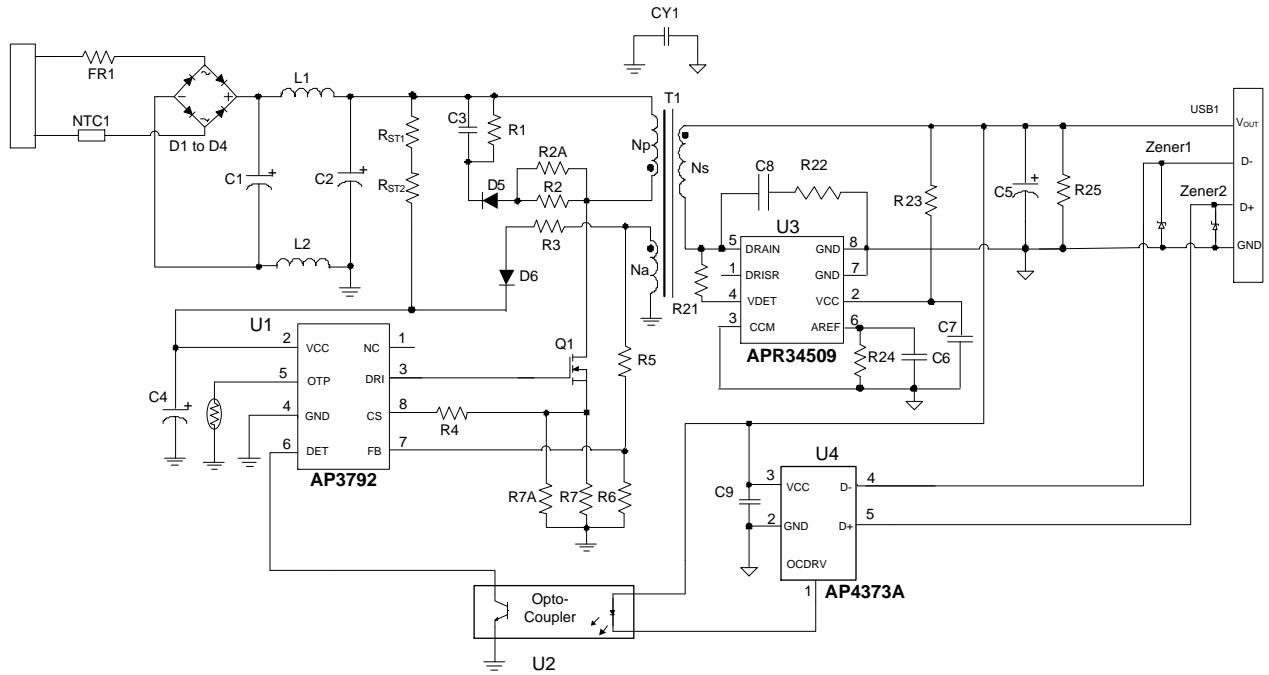

Pin Descriptions

Pin Number	Pin Name	Function
1	OCDRV	Used for opto-coupler LED driver transferring signals to primary side via opto-coupler
2	GND	The ground of the IC
3	VCC	The power supply of the IC, connected to a ceramic capacitor
4	D-	Connected to USB D-
5	D+	Connected to USB D+

Functional Block Diagram

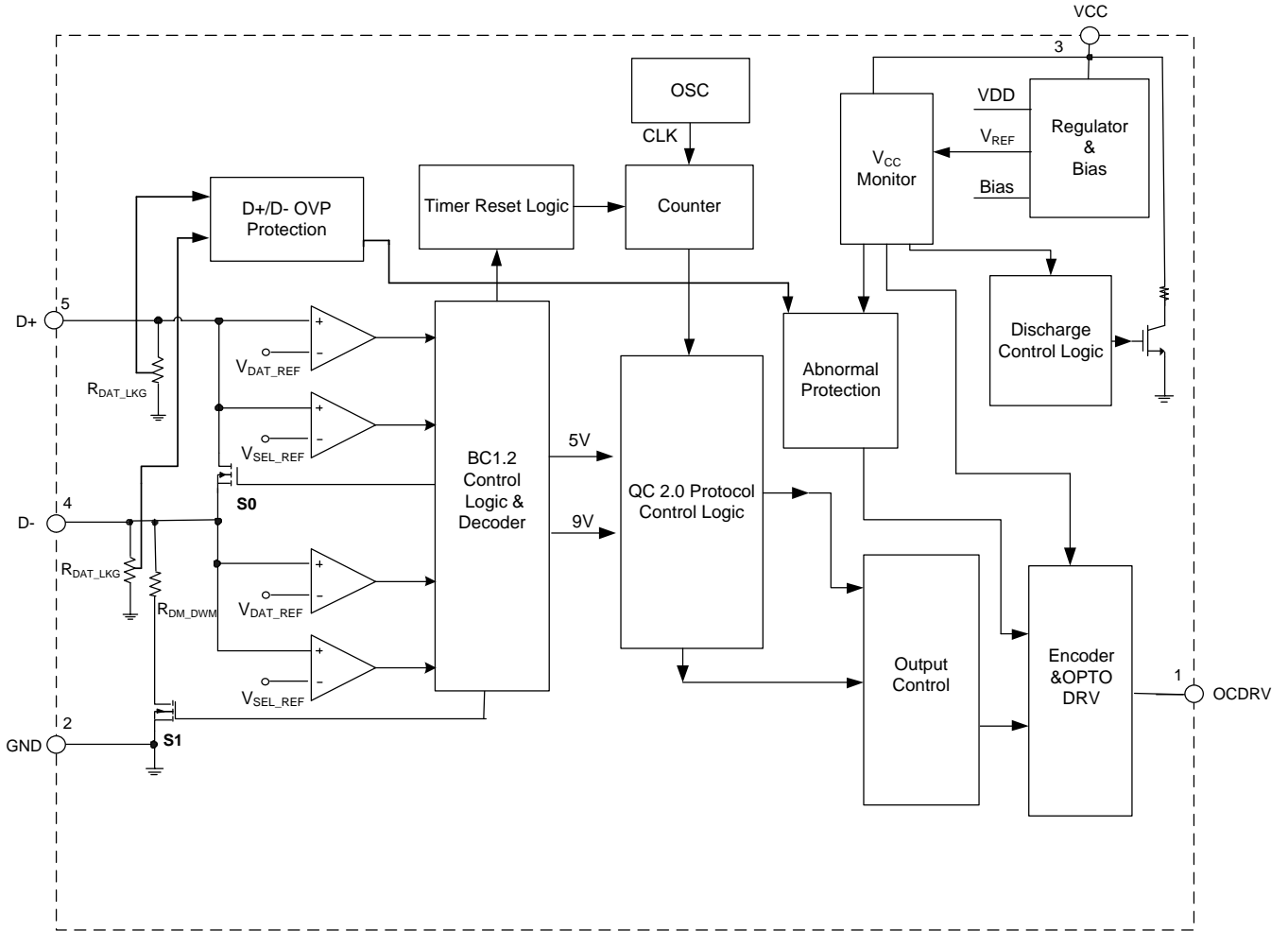

Absolute Maximum Ratings (Note 4)

Symbol	Parameter	Rating	Unit
V _{CC}	Voltage at VCC to GND	-0.3 to 20	V
V _{OCDRV}	Voltage at OCDRV to GND	-0.3 to 20	V
—	Voltage at D+, D- to GND	-0.3 to 7	V
T _J	Operating Junction Temperature (Note 5)	-40 to +150	°C
T _{STG}	Storage Temperature	-65 to +150	°C
T _{LEAD}	Lead Temperature (Soldering, 10s)	+300	°C
θ _{JC}	Thermal Resistance (Junction to Case)	42	°C/W
θ _{JA}	Thermal Resistance (Junction to Ambient) (Note 5)	180	°C/W
—	ESD (Human Body Model)	8000	V
—	ESD (Charged Device Model)	2000	V

- Notes:
- Stresses greater than those listed under "Absolute Maximum Ratings" can cause permanent damage to the device. These are stress ratings only, and functional operation of the device at these or any other conditions beyond those indicated under "Recommended Operating Conditions" is not implied. Exposure to "Absolute Maximum Ratings" for extended periods can affect device reliability.
 - Test condition: Device mounted on FR-4 substrate PC board, 2oz copper, with 1inch² cooling area.

Recommended Operating Conditions

Symbol	Parameter	Min	Max	Unit
V _{CC}	Power Supply Voltage	4.5	9	V
T _A	Ambient Temperature	-40	+85	°C

Electrical Characteristics (@V_{CC}=5V, -40°C <T_A<+85°C, unless otherwise specified.)

Symbol	Parameter	Condition	Min	Typ	Max	Unit
VCC PIN SECTION						
V _{ST}	Startup Voltage	—	3.5	3.8	4.1	V
V _{UVLO}	Minimum Operating Voltage	—	2.8	3.0	3.2	V
I _{ST}	Startup Current	—	—	75	100	μA
I _{CC_OP}	Operating Supply Current	Static Current	150	200	250	μA
OCDRV PIN SECTION						
I _{OCDRV}	Opto-Coupler Current	—	6	7.5	10	mA
NO LOAD AND DYNAMIC SECTION						
V _{TRL_5V}	Trigger Voltage for No Load Mode and Dynamic	T _A = +25°C	5.0	5.06	5.12	V
V _{TRL_9V}		T _A = +25°C	8.6	8.75	8.9	V
PROTECTION FUNCTION SECTION						
V _{OVP_5V}	OVP Enable Voltage and Abnormal OVP Enable Voltage	T _A = +25°C	5.65	5.85	6.05	V
V _{OVP_9V}		T _A = +25°C	10	10.4	10.8	V
V _{OVP_DIS_5V}	Discharge Voltage, OVP Disable Voltage and Discharge Current Disable Voltage when Voltage Switches Down	T _A = +25°C	5.06	5.19	5.32	V
V _{OVP_DIS_9V}		T _A = +25°C	9.26	9.5	9.74	V
I _{DIS}	Discharge Current for V _{OVP_DIS}	—	4	6	8	mA
t _{DIS}	Maximum Period	—	8	9	10	ms
I _{OVP}	OVP Discharge Current	—	70	115	160	mA
t _{OVP}	OVP Discharge Current Maximum Time Duration and Abnormal OVP Debounce Time	—	80	100	120	ms
QC2.0 DECODER(D+/D- PIN) SECTION						
V _{DAT_REF}	Data Detect Voltage	—	0.25	0.325	0.40	V
V _{SEL_REF}	Output Voltage Selection Reference	—	1.8	2.0	2.2	V
V _{OTG_SESS_VLD}	Minimum HVDCP Output Voltage at which D+ to D- must be Shorted	—	0.8	—	4.0	V
R _{DAT_LKG}	Data Line Leakage Resistance	—	300	500	800	kΩ
R _{DCP_DAT}	D+ to D- Resistance during DCP Mode	D+ is Supplied with 0.6V	—	20	40	Ω
R _{DM_DWM}	D- Pull-Down Resistance	—	14.25	19.53	24.80	kΩ
t _{GLITCH_BC_DONE}	D+ High Glitch Filter Time	—	1	1.28	1.4	s
t _{GLITCH_DM_LOW}	D- Low Glitch Filter Time	Note 6	1.0	2.5	4.0	ms
t _{D+_D-_SHORT}	D+ and D- HVDCP Short Time	—	—	10	20	ms
t _{GLITCH_DP_LOW}	D+ Low Glitch Filter Time	—	40	45	50	ms
C _{DCP_PWR}	D+/- Equivalent Capacitance	Note 6	—	—	0.5	nF
V _{OVP_D+}	D+ Line Over Voltage Protection Threshold	—	4.1	4.3	4.7	V
V _{OVP_D-}	D- Line Over Voltage Protection Threshold	—	4.1	4.3	4.7	V

Note: 6. These parameters are not 100% tested, guaranteed by design and characterization.

Operation Description

Overall Introduction

The figure on page 2 is *Typical Application Circuit* of AP4373A, which follows QC 2.0 Protocol to decode the different combinations of D+/D- signals, generated by the portable device, into the OCDRV pin for the controller IC to make the further constant voltage/constant current control. The AP4373A automatically provides 5V output configuration for the connected portable device that is not suitable for the QC 2.0 protocol.

Common Communication Handshake

The common communication handshake rule of QC 2.0 Protocol is described as following:

The switches of S1 (shown in *Functional Block Diagram* on page 3) will be kept turn-off during the start-up phase, S0 switch will be turned on to short D+ to D- at start-up voltage within $V_{OTG_SESS_VLD}$ (0.8V to 4.0V). The default configuration ensures that the charger/adaptor is regulated into 5V output voltage. If AP4373A finds D+ voltage is between V_{DAT_REF} (0.325V, typical) and V_{SEL_REF} (2.0V, typical) lasting for $t_{GLITCH_BC_DONE}$, it will turn off S0 to have D+ / D- open, and turn on S1 to have D- connected to GND via R_{DM_DWM} (19.53k Ω , typical). The AP4373A will ensure that D- stays low voltage for more than $t_{GLITCH_DM_LOW}$ (1ms, minimum) to successfully complete protocol handshake. After that, the AP4373A can follow QC 2.0 Protocol to configure OCDRV. Finally, after the portable device is removed from USB connector, the AP4373A will have D+ shorted to D- within $t_{D+_D_SHORT}$ (20ms, maximum), configure OCDRV to 5V output, and is ready for next handshake.

NL Mode Operation (Typical Application with AP4373A)

At no load and ultralight load, the output voltage is under control by AP4373A. For NL working state, when the AP4373A detects the output voltage is lower than its trigger voltage, the AP4373A OCDRV pin emits a periodical pulse current. This pulse current will generate a periodical pulse voltage on DET pin of AP3792 through the opto-coupler, then the AP3792 provides energy to turn on primary switch to supply output terminal and primary VCC voltage.

Protection

The AP4373A has several built-in fault protection functions, such as output over voltage protection, D+ and D- over voltage protection. The AP4373A will restart the system when the output voltage excesses V_{OVP_5V} (V_{OVP_9V}) while system is operated at 5V (9V) output or the voltage of D+ (D-) excesses V_{OVP_D+} (V_{OVP_D-}).

Ordering Information

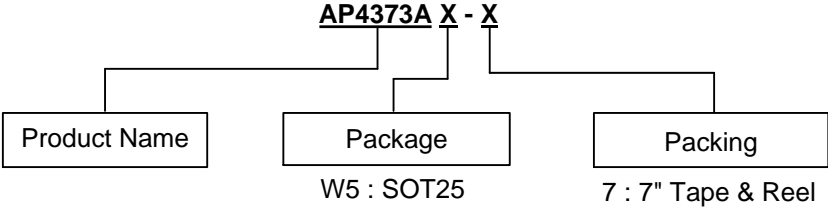

Package	Temperature Range	Part Number	Identification Code	7" Tape and Reel	
				Quantity	Part Number Suffix
SOT25	-40 to +85°C	AP4373AW5-7	A8	3000/Tape and Reel	-7

Marking Information

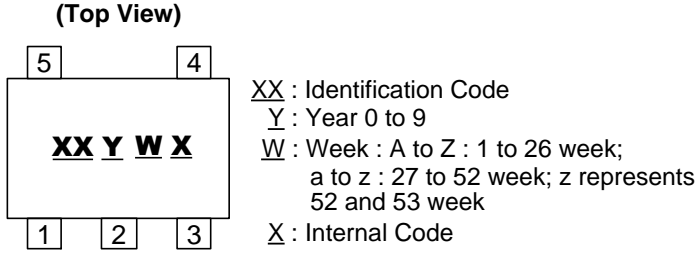

Package Outline Dimensions (All dimensions in mm(inch).)

Please see <http://www.diodes.com/package-outlines.html> for the latest version.

(1) Package Type: SOT25

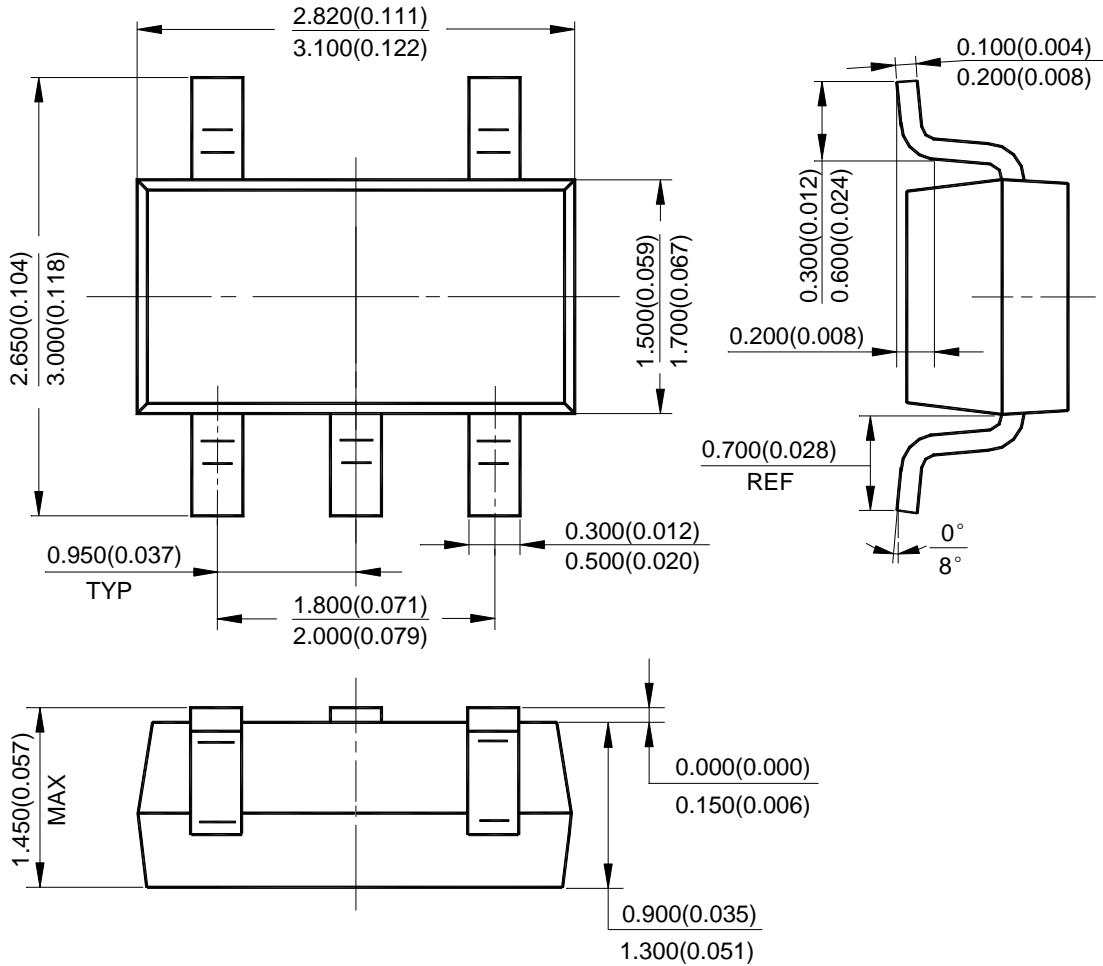

Suggested Pad Layout

Please see <http://www.diodes.com/package-outlines.html> for the latest version.

(1) Package Type: SOT25

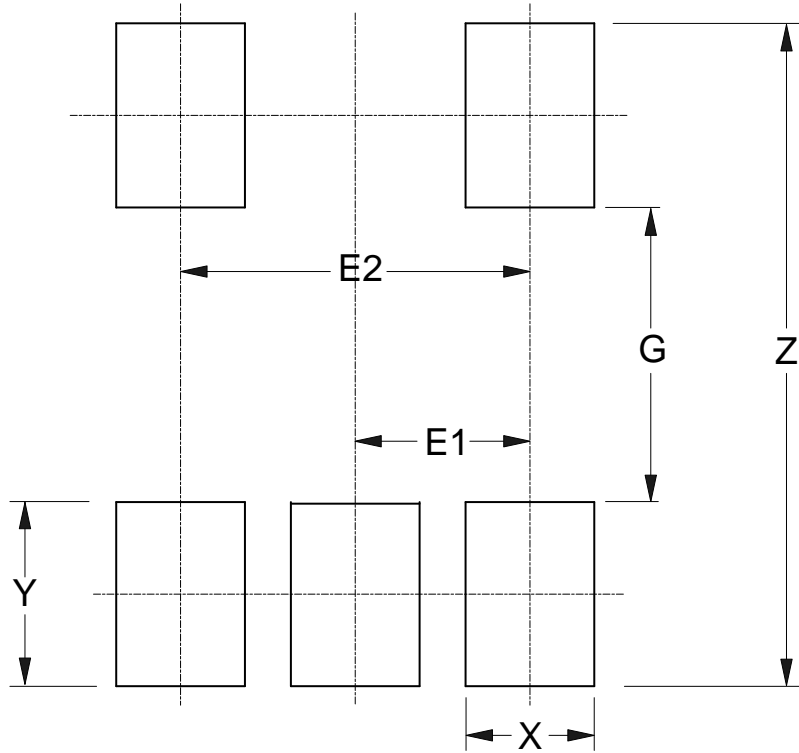

Dimensions	Z (mm)/(inch)	G (mm)/(inch)	X (mm)/(inch)	Y (mm)/(inch)	E1 (mm)/(inch)	E2 (mm)/(inch)
Value	3.600/0.142	1.600/0.063	0.700/0.028	1.000/0.039	0.950/0.037	1.900/0.075

Mechanical Data

- Moisture Sensitivity: MSL Level 3 per J-STD-020
- Terminals: Finish – Matte Tin Plated Leads, Solderable per JESD22-B102 (Ⓔ)
- Weight: 0.016 grams (Approximate)

IMPORTANT NOTICE

DIODES INCORPORATED MAKES NO WARRANTY OF ANY KIND, EXPRESS OR IMPLIED, WITH REGARDS TO THIS DOCUMENT, INCLUDING, BUT NOT LIMITED TO, THE IMPLIED WARRANTIES OF MERCHANTABILITY AND FITNESS FOR A PARTICULAR PURPOSE (AND THEIR EQUIVALENTS UNDER THE LAWS OF ANY JURISDICTION).

Diodes Incorporated and its subsidiaries reserve the right to make modifications, enhancements, improvements, corrections or other changes without further notice to this document and any product described herein. Diodes Incorporated does not assume any liability arising out of the application or use of this document or any product described herein; neither does Diodes Incorporated convey any license under its patent or trademark rights, nor the rights of others. Any Customer or user of this document or products described herein in such applications shall assume all risks of such use and will agree to hold Diodes Incorporated and all the companies whose products are represented on Diodes Incorporated website, harmless against all damages.

Diodes Incorporated does not warrant or accept any liability whatsoever in respect of any products purchased through unauthorized sales channel. Should Customers purchase or use Diodes Incorporated products for any unintended or unauthorized application, Customers shall indemnify and hold Diodes Incorporated and its representatives harmless against all claims, damages, expenses, and attorney fees arising out of, directly or indirectly, any claim of personal injury or death associated with such unintended or unauthorized application.

Products described herein may be covered by one or more United States, international or foreign patents pending. Product names and markings noted herein may also be covered by one or more United States, international or foreign trademarks.

This document is written in English but may be translated into multiple languages for reference. Only the English version of this document is the final and determinative format released by Diodes Incorporated.

LIFE SUPPORT

Diodes Incorporated products are specifically not authorized for use as critical components in life support devices or systems without the express written approval of the Chief Executive Officer of Diodes Incorporated. As used herein:

A. Life support devices or systems are devices or systems which:

1. are intended to implant into the body, or
2. support or sustain life and whose failure to perform when properly used in accordance with instructions for use provided in the labeling can be reasonably expected to result in significant injury to the user.

B. A critical component is any component in a life support device or system whose failure to perform can be reasonably expected to cause the failure of the life support device or to affect its safety or effectiveness.

Customers represent that they have all necessary expertise in the safety and regulatory ramifications of their life support devices or systems, and acknowledge and agree that they are solely responsible for all legal, regulatory and safety-related requirements concerning their products and any use of Diodes Incorporated products in such safety-critical, life support devices or systems, notwithstanding any devices- or systems-related information or support that may be provided by Diodes Incorporated. Further, Customers must fully indemnify Diodes Incorporated and its representatives against any damages arising out of the use of Diodes Incorporated products in such safety-critical, life support devices or systems.

Copyright © 2020, Diodes Incorporated

www.diodes.com

单击下面可查看定价，库存，交付和生命周期等信息

[>>Diodes Incorporated\(达达科技\(美台\)\)](#)