

Features

- Single differential LVPECL output
- Supports the following output frequencies: 125MHz or 133MHz
- RMS phase jitter @ 125MHz, using a 25MHz crystal (12kHz – 20MHz): 0.3ps (typical)
- Full 3.3V or 2.5V supply modes
- Commercial and industrial ambient operating temperature
- Available in lead-free package: 8-TSSOP

Applications

- Networking systems

Description

The PI6LC48P21 is a single output LVPECL synthesizer optimized to generate Ethernet reference clock frequencies and is a member of Pericom's HiFlex family of high performance clock solutions. Using a 25MHz or 26.6MHz crystal, it can generate 125MHz or 133MHz output frequencies.

The PI6LC48P21 uses Pericom's proprietary low phase noise PLL technology to achieve ultra low phase jitter, so it is ideal for Ethernet interface in all kind of systems.

Block Diagram

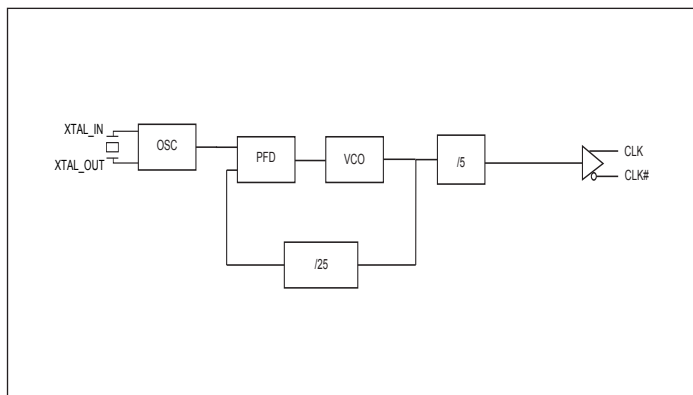

Pin Configuration

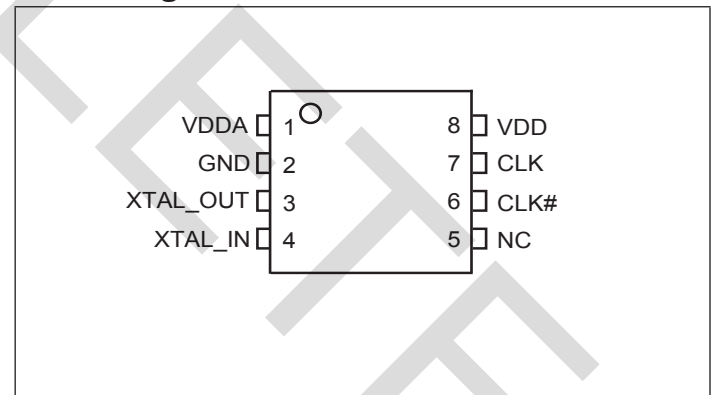

Pinout Table

Pin No.	Pin Name	I/O Type	Description
1	VDDA	Power	Analog Power Supply
2	GND	Power	Ground
3, 4	XTAL_OUT, XTAL_IN	Crystal	Crystal Input and Output
5	NC		No Connect
6, 7	CLK#, CLK	Output	Output Clock
8	VDD	Power	Core Power Supply

Output Frequency Table

Xtal Frequency (MHz)	Output Frequency (MHz)
25	125
26.6	133

Typical Crystal Requirement

Parameter	Minimum	Typical	Maximum	Units
Mode of Oscillation	Fundamental			
Frequency	22.4	25	28	MHz
Equivalent Series Resistance (ESR)			50	Ω
Shunt Capacitance			7	pF
Drive Level			1	mW

Recommended Crystal Specification

Pericom recommends:

- a) FL2500047, SMD 3.2x2.5(4P), 25MHz, CL=18pF, +/-20ppm
<http://www.pericom.com/pdf/datasheets/se/FL.pdf>
- b) FY2500091, SMD 5x3.2(4P), 25MHz, CL=18pF, +/-30ppm
http://www.pericom.com/pdf/datasheets/se/FY_F9.pdf

Maximum Ratings (Over operating free-air temperature range)

Storage Temperature.....	-65°C to +155°C
Ambient Temperature with Power Applied.....	-40°C to +85°C
3.3V Analog Supply Voltage.....	-0.5 to +3.6V
ESD Protection (HBM)	2000V

Note:

Stresses greater than those listed under MAXIMUM RATINGS may cause permanent damage to the device. This is a stress rating only and functional operation of the device at these or any other conditions above those indicated in the operational sections of this specification is not implied. Exposure to absolute maximum rating conditions for extended periods may affect reliability.

DC Electrical Characteristics

Power Supply DC Characteristics, ($V_{DD} = V_{DDA}$, $T_A = -40$ to 85°C)

Symbol	Parameter	Condition	Min	Typ	Max	Units
V_{DD}, V_{DDA}	Core, Analog Supply Voltage		3.0	3.3	3.6	V
V_{DD}, V_{DDA}	Core, Analog Supply Voltage		2.375	2.5	2.625	V
GND	Power Supply Current				85	mA
I_{DDA}	Analog Supply Current				25	mA

LVPECL DC Electrical Characteristics

Symbol	Parameter	Condition	Min	Typ	Max	Units
V_{OH}	Output High Voltage ⁽¹⁾	$V_{DD} = 3.3\text{V}$	1.9		2.4	V
		$V_{DD} = 2.5\text{V}$	1.1		1.6	
V_{OL}	Output Low Voltage ⁽¹⁾	$V_{DD} = 3.3\text{V}$	1.2		1.6	V
		$V_{DD} = 2.5\text{V}$	0.4		0.8	

Note: 1. LVPECL Termination: Source 150ohm to GND and 100ohm across CLK and CLK#.

LVPECL AC Electrical Characteristics

LVPECL Termination: Source 150ohm to GND and using 0.01uF ac-coupled to 50ohm to GND

Symbol	Parameter	Condition	Min.	Typ.	Max	Units
f_{OUT}	Output Frequency		112	125	140	MHz
$t_{jit(\omega)}$	RMS Phase Jitter, (Random) ⁽¹⁾	125MHz, (1.875MHz - 20MHz)		0.15		ps
		125MHz, (12kHz - 20MHz)		0.3		ps
t_R / t_F	Output Rise/Fall Time	20% to 80%			400	ps
σ_{DC}	Output Duty Cycle		48		52	%

Note:

1. Please refer to the Phase Noise Plots.

Phase Noise Plot

125MHz Output

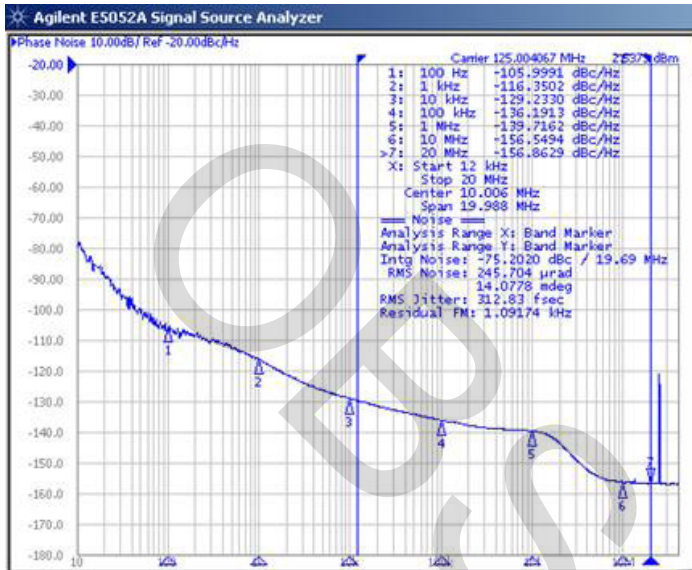

133MHz Output

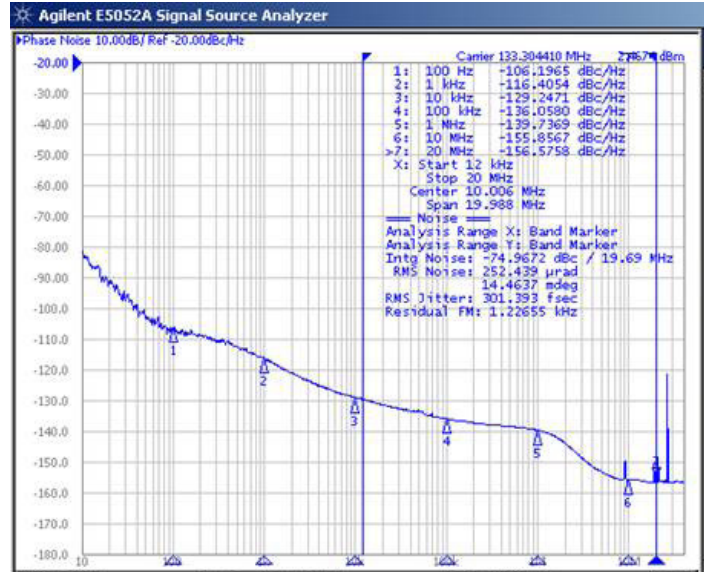

LVPECL Test Circuit

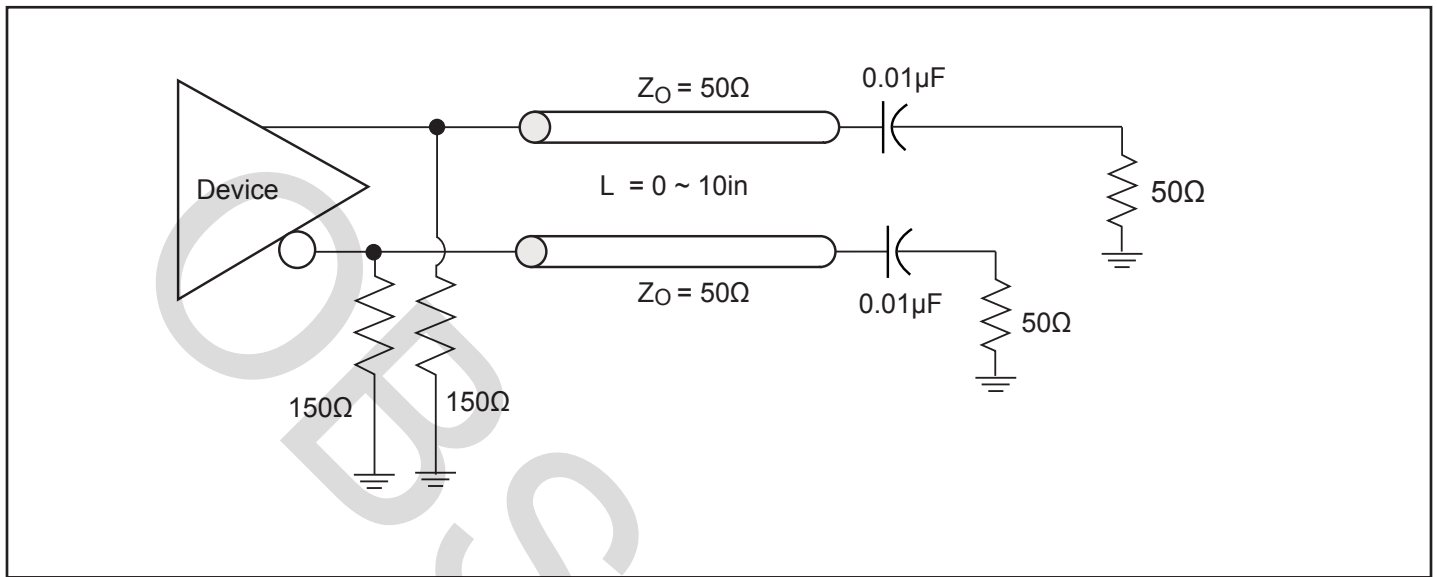

Power Supply Filtering Techniques

As in any high speed analog circuitry, the power supply pins are vulnerable to random noise. To achieve optimum jitter performance, power supply isolation is required. The PI6LC48P21 provides separate power supplies to isolate any high switching noise from the outputs to the internal PLL. V_{DD} and V_{DDA} should be individually connected to the power supply plane through vias, and $0.1\mu\text{F}$ bypass capacitors should be used for each pin. Figure below illustrates this for a generic V_{DD} pin and also shows that V_{DDA} requires that an additional 10Ω resistor along with a $10\mu\text{F}$ bypass capacitor be connected to the V_{DDA} pin.

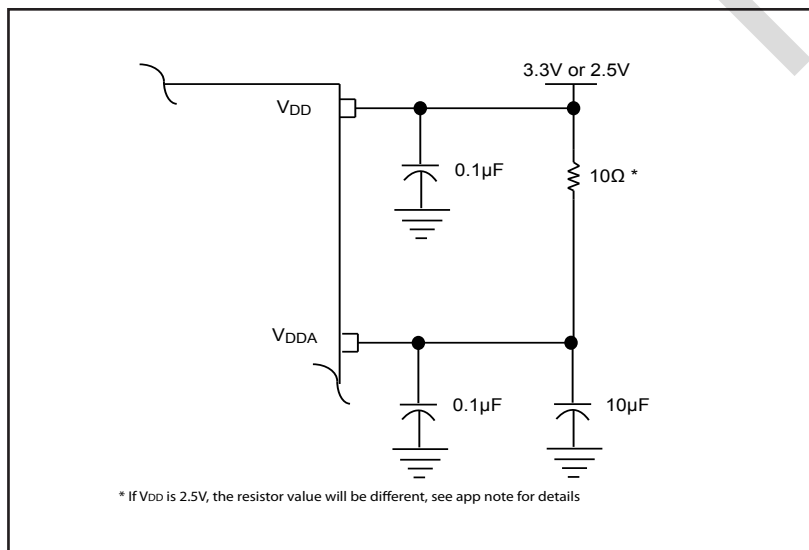

Crystal Input Interface

The clock generator has been characterized with 18pF parallel resonant crystals. The capacitor values shown in the figure below were determined using a 25MHz, 18pF parallel resonant crystal and were chosen to minimize the ppm error.

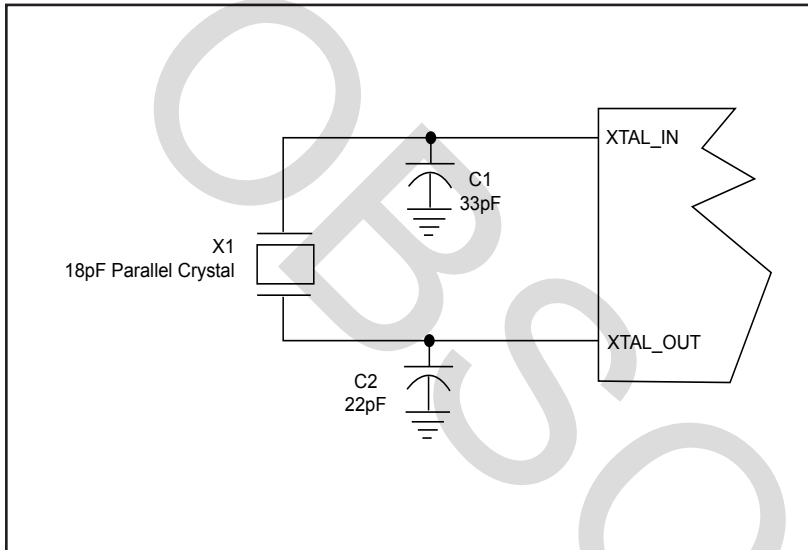

LVC MOS to XTAL Interface

The XTAL_IN input can accept a single-ended LVC MOS signal through an AC coupling capacitor. A general interface diagram is shown in the figure below. The XTAL_OUT pin can be left floating. The input edge rate can be as slow as 10ns. For LVC MOS signals, it is recommended that the amplitude be reduced from full swing to half swing in order to prevent signal interference with the power rail and to reduce noise. This configuration requires that the output impedance of the driver (R_o) plus the series resistance (R_s) equals the transmission line impedance. In addition, matched termination at the crystal input will attenuate the signal in half. This can be done in one of the two ways. First, R_1 and R_2 in parallel should equal the transmission line impedance. For most 50Ω applications, R_1 and R_2 can be 100Ω. This can also be accomplished by removing R_1 and making R_2 50Ω. By overdriving the crystal oscillator, the device will be functional, but note, the device performance is guaranteed by using a quartz crystal.

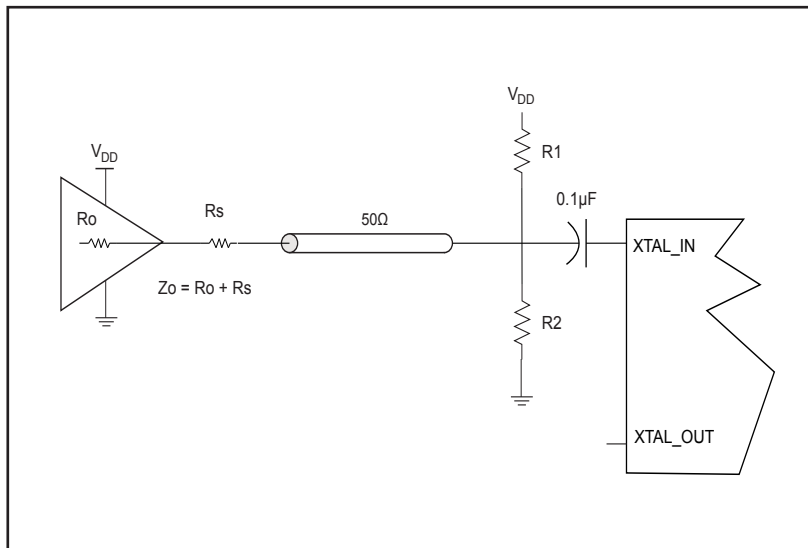

Packaging Mechanical: 8-Contact TSSOP (L)

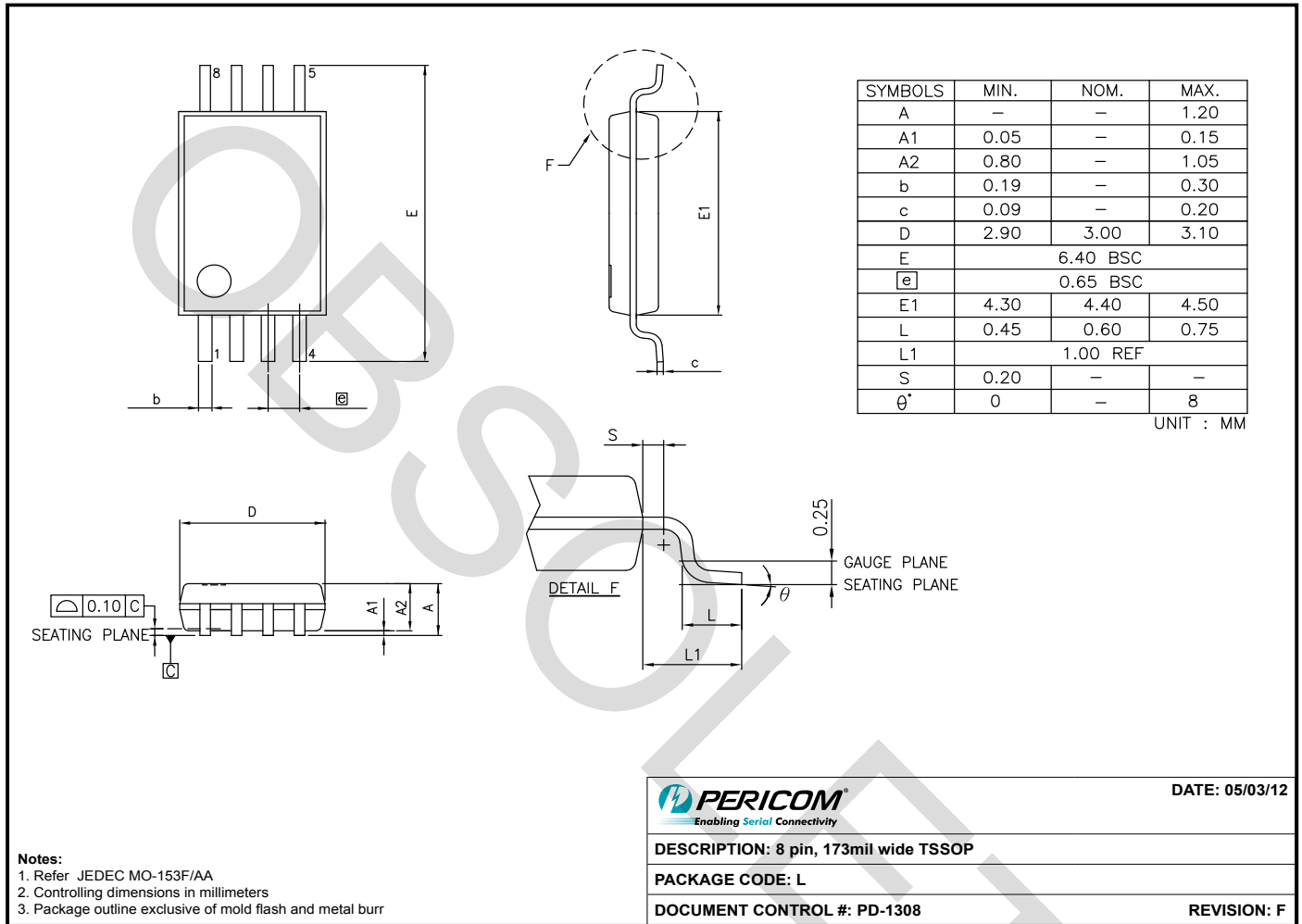

Notes:
 1. Refer JEDEC MO-153F/AA
 2. Controlling dimensions in millimeters
 3. Package outline exclusive of mold flash and metal burr

PERICOM Enabling Serial Connectivity	DATE: 05/03/12
DESCRIPTION: 8 pin, 173mil wide TSSOP	
PACKAGE CODE: L	
DOCUMENT CONTROL #: PD-1308	REVISION: F

12-0370

Ordering Information

Ordering Code	Packaging Type	Package Description	Operating Temperature
PI6LC48P21LE	L	Pb-free & Green, 8-pin TSSOP	Commercial
PI6LC48P21LIE	L	Pb-free & Green, 8-pin TSSOP	Industrial

Notes:

- Thermal characteristics can be found on the company web site at www.pericom.com/packaging/
- "E" denotes Pb-free and Green
- Adding an "X" at the end of the ordering code denotes tape and reel packaging

单击下面可查看定价，库存，交付和生命周期等信息

[>>Diodes Incorporated\(达达科技\(美台\)\)](#)