

4-Port HDMI™ Signal Switch with I²C Control**Features**

- 4:1 HDMI Switch Mux
- Non-Blocking EQ path for ideal EQ control in main Receiver chipset
- -3dB bandwidth up to 5Gbps to support HDMI 1.3a (16-bit color depth per channel)
- HDMI 1.4 data rate ready
- DDC active signal buffer or passive switch selectable
- I²C Register control for switch configuration
- Automatic HDCP reset circuitry for quick communication when switching from one port to another
- HPD polarity control and signal trigger through I²C register setting
- Connector Plug-in detection and Interrupt Flag setting
- Selectable HPD 5V signal level shifter with open drain output stage or output buffer
- 3.3V power supply and standby power supply
- TMDS output enable control
- Low power consumption to support Energy Star Compliance
- ESD protection on all I/O pins
 - 8kV contact per IEC61000-4-2, level 4
- Packaging (Pb-free & Green available):
 - 80-contact LQFP

Description

Pericom Semiconductor's PI3HDMI series of switch circuits are targeted for high-resolution video networks that are based on DVI/HDMI™ standards. The PI3HDMI2410 is a 4-to-1 HDMI Mux/DeMux signal switch. It is designed for low bit-to-bit skew and high channel-to-channel noise isolation. The maximum data rate support is up to 5Gbps which can meet HDMI 1.3a standard and support the resolution requirement of next generation HDTV and PC graphics.

PI3HDMI2410 is designed specifically for ATC-Sink requirements. All switch control settings are through I²C bus to provide flexible design and reducing peripheral components. Selectable active signal buffer for DDC bus can optimize the bi-directional data transmission for long trace or cable applications.

All input pins are protected with Pericom's ESD protection circuits supporting ESD damage as high as 8kV contact per IEC61000-4-2 Level 4 specification.

Block Diagram

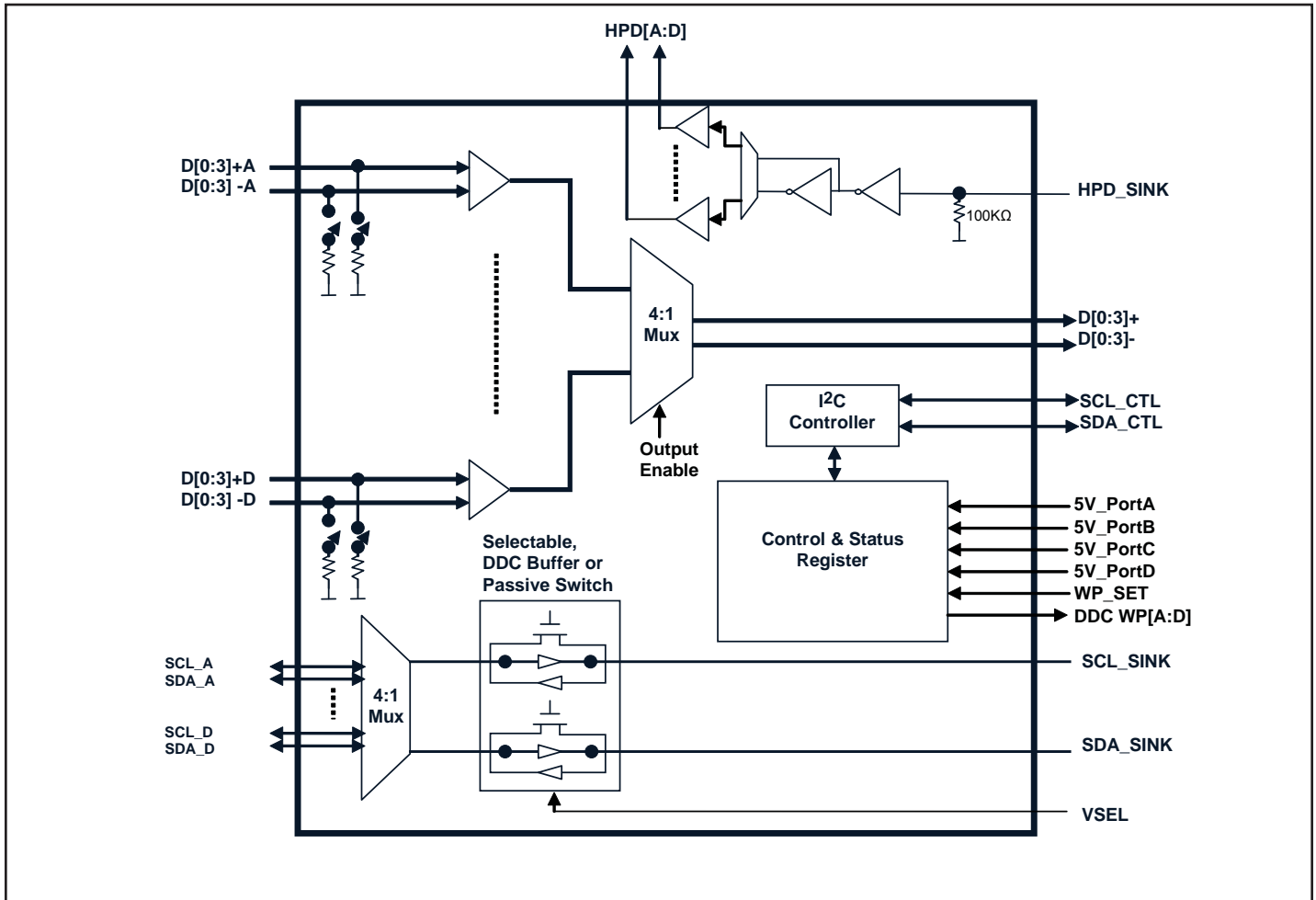

Pin Assignment – 80-Contact LQFP

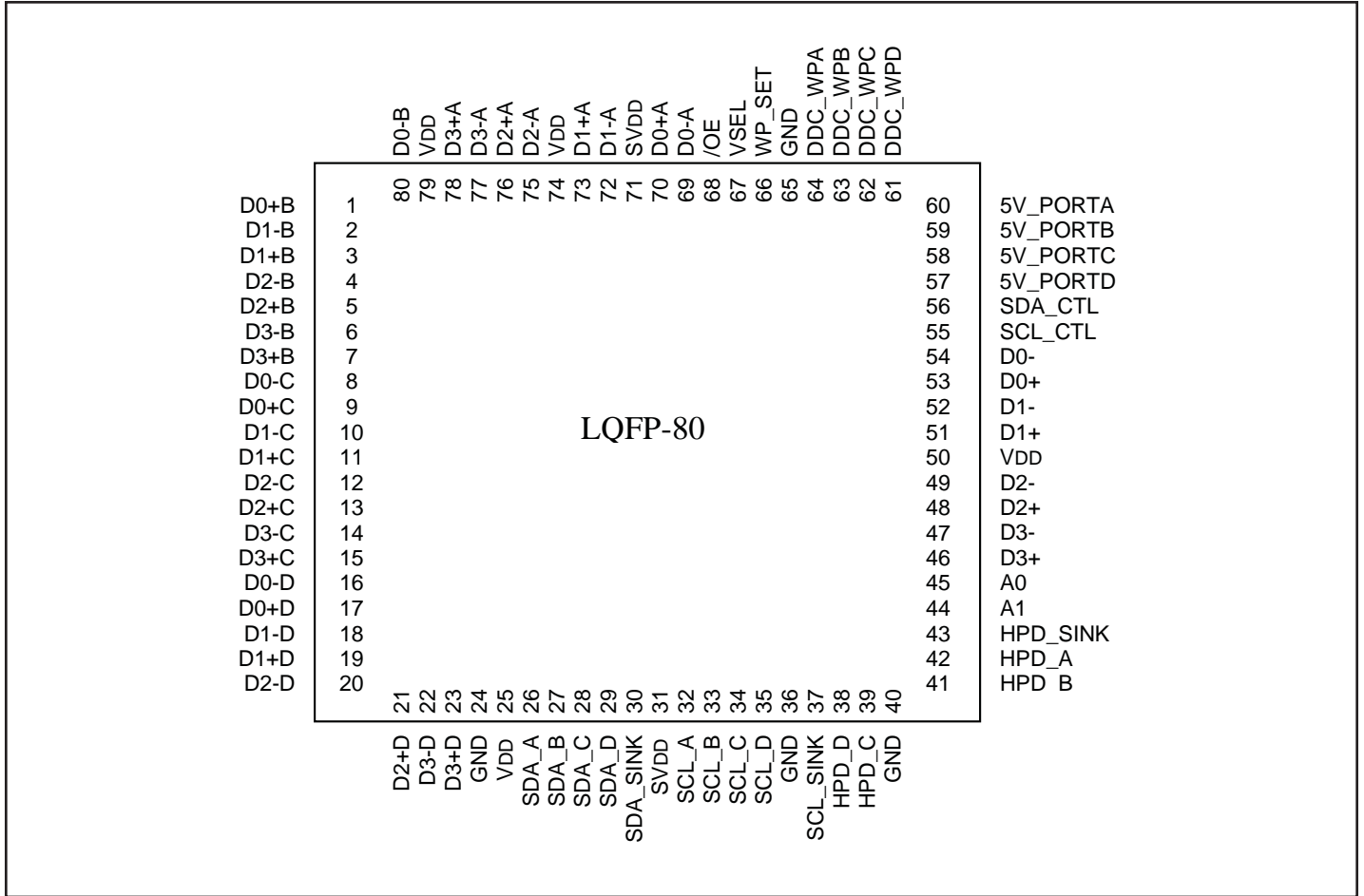

Pinout Table

| Pin Name | I/O Type | Description |
|--|----------|--|
| V _{DD} | I/O | 3.3V power supply. When V _{DD} is off, the TMDS channels will be powered down. |
| SV _{DD} | I/O | 3.3V standby power supply. SV _{DD} is for all side band signals, I ² C register and I ² C bus. |
| HPD_SINK | I | Sink side hot plug detector input. High: 5-V power signal asserted from source to sink and EDID is ready. Low: No 5-V power signal asserted from source to sink, or EDID is not ready. |
| HPD_A | O | Port A HPD output |
| HPD_B | O | Port B HPD output |
| HPD_C | O | Port C HPD output |
| HPD_D | O | Port D HPD output |
| D0+A D0-A D1+A D1-A D2+A D2-A D3+A D3-A | I | Port A TMDS inputs |
| D0+B D0-B D1+B D1-B D2+B D2-B D3+B D3-B | I | Port B TMDS inputs |
| D0+C D0-C D1+C D1-C D2+C D2-C D3+C D3-C | I | Port C TMDS inputs |

| Pin Name | I/O Type | Description |
|--|----------|---|
| D0+D D0-D D1+D D1-D D2+D D2-D D3+D D3-D | I | Port D TMDS inputs |
| D0+ D0- D1+ D1- D2+ D2- D3+ D3- | O | TMDS outputs |
| SCL_A | I/O | Port A DDC Clock |
| SCL_B | I/O | Port B DDC Clock |
| SCL_C | I/O | Port C DDC Clock |
| SCL_D | I/O | Port D DDC Clock |
| SDA_A | I/O | Port A DDC Data |
| SDA_B | I/O | Port B DDC Data |
| SDA_C | I/O | Port C DDC Data |
| SDA_D | I/O | Port D DDC Data |
| SCL_SINK | I/O | Sink side DDC Clock |
| SDA_SINK | I/O | Sink side DDC Data |
| SCL_CTL | I/O | I ² C Clock |
| SDA_CTL | I/O | I ² C Data |
| WP_SET | I | WP_SET = 0 (Default), Set B1b[1] as INT Flag. WP_SET = 1, DDC_WP[A:D] is programmable by B1b[1]. |
| DDC_WPA, DDC_WPB, DDC_WPC, DDC_WPD, | O | Open drain output. When WP_SET = 1, general purpose logic configured by B1b[1] |
| \overline{OE} | I | Output Enable control. Active low. |
| A1 | I | I ² C Address 1 |
| A0 | I | I ² C Address 0 |

| Pin Name | I/O Type | Description |
|---|----------|---|
| 5V_PortA, 5V_PortB, 5V_PortC, 5V_PortD | I | Connector 5V port. |
| VSEL | I | DDC buffer V _{IL} selection. VSEL = 0V, V _{IL} = 0.5V VSEL = 0.5 V _{DD} , V _{IL} =0.45V VSEL = V _{DD} , V _{IL} =0.6V |

Truth Table

| WP_SET | B1_b[1] | DDC_WP[A:D] |
|--------|---------|-------------|
| 1 | 0 | Hi_Z |
| 1 | 1 | 0 |
| 0 | X | Hi_Z |

I²C Control Register

| | b7 | b6 | b5 | b4 | b3 | b2 | b1 | b0 |
|--------------|----|----|----|----|----|---------------------------|---------------------------|-------|
| Address Byte | 1 | 0 | 1 | 0 | 1 | A1 Hardware Selectable | A0 Hardware Selectable | 0/1 * |

* 0:Write; 1:Read

Data Byte 0: Control Register

| Bit | Description | Type | Power Up Condition | Logic Settings |
|-----|---------------------------|------|--------------------|---|
| 7 | HDMI input port selection | R/W | 0 | 00 = Port A 01 = Port B |
| 6 | HDMI input port selection | R/W | 0 | 10 = Port C 11 = Port D |
| 5 | HPD Logic Selection | R/W | 1 | 0 = Inverted 1 = Non Inverted |
| 4 | HPD Input Selection | R/W | 0 | 0 = HPD_SINK 1 = I ² C Register Setting B0b[3:0] |
| 3 | HPD Port D Logic Setting | R/W | 0 | I. Byte0 b[4] = 1 HPD Port D Register setting II. Byte0 b[4] = 0 Test mode |
| 2 | HPD Port C Logic Setting | R/W | 0 | I. Byte0 b[4] = 1 HPD Port C Register setting II. Byte0 b[4] = 0 Test mode |
| 1 | HPD Port B Logic Setting | R/W | 0 | I. Byte0 b[4] = 1 HPD Port B Register setting II. Byte0 b[4] = 0 Test mode |
| 0 | HPD Port A Logic Setting | R/W | 0 | I. Byte0 b[4] = 1 HPD Port A Register setting II. Byte0 b[4] = 0 Test mode |

Data Byte 1: Control Register

| Bit | Description | Type | Power Up Condition | Logic Settings |
|-----|----------------------------|------|--------------------|--|
| 7 | HPD Output Stage selection | R/W | 0 | 0 = Open Drain 1 = Output Buffer |
| 6 | Output Enable | R/W | 1 | 0 = Output Disable (also drives switch into power down mode) 1 = Output Enable |
| 5 | 5V_Port D connect | R | 0 | 0 = Disconnected 1 = Connected; Set INT Flag |
| 4 | 5V_Port C connect | R | 0 | 0 = Disconnected 1 = Connected; Set INT Flag |
| 3 | 5V_Port B connect | R | 0 | 0 = Disconnected 1 = Connected; Set INT Flag |
| 2 | 5V_Port A connect | R | 0 | 0 = Disconnected 1 = Connected; Set INT Flag |
| 1 | INT Flag | R/W | 0 | When WP_SET = 0, B1b[1] is configured as INT flag. 0 = INT Flag Clear 1 = INT Flag Set When WP_SET = 1, B1b[1] is configured as DDC_WP input setting. |
| 0 | DDC channel selection | R/W | 0 | 0 = Passive switch 1 = Active switch buffer |

* External hardware control pin WP_SET will set B1b1 to be INT Flag or DDC_WP[0:3] input.

Bus transactions

Data transfers follow the format shown in Fig.1. After the START condition (S), a slave address is sent. This address is 7 bits long followed by an eighth bit which is a data direction bit (R/W) - a 'zero' indicates a transmission (WRITE), a 'one' indicates a request for data (READ). A data transfer is always terminated by a STOP condition (P) generated by the master. However, if a master still wishes to communicate on the bus, it can generate a repeated START condition (Sr) and address another slave without first generating a STOP condition. Various combinations of read/write formats are then possible within such a transfer.

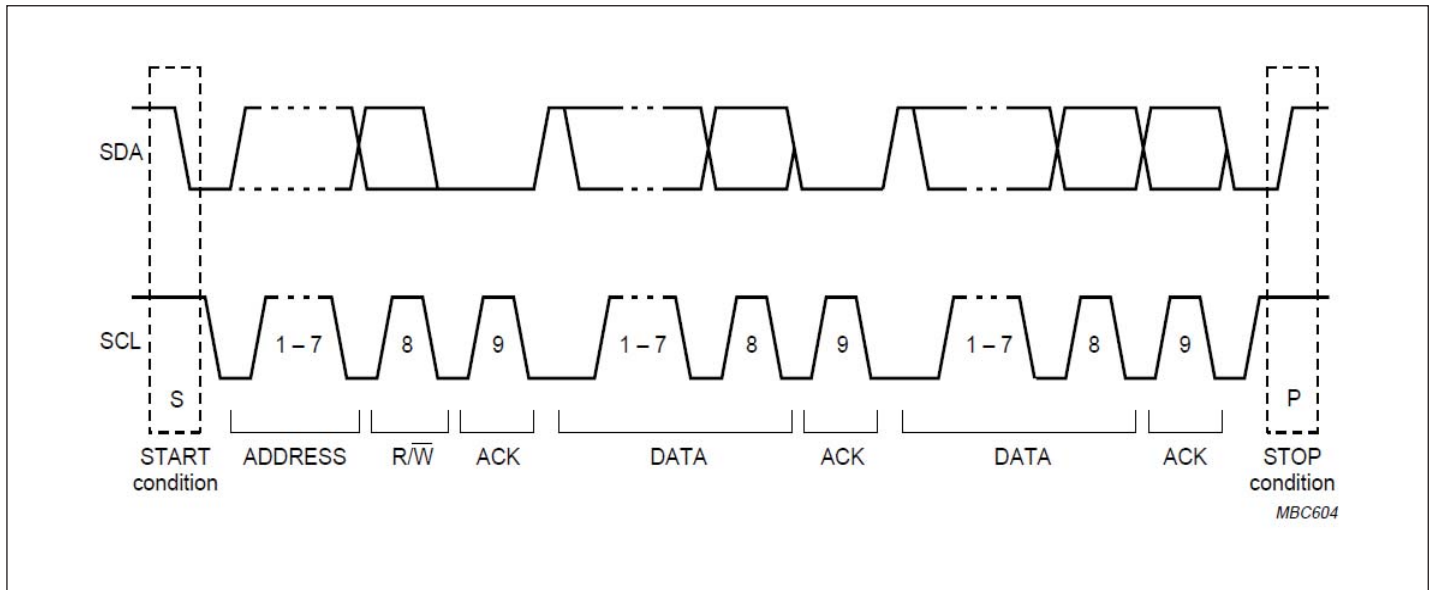

Figure 1: A Complete Data Transfer

Data is transmitted to the PI3HDMI2410 registers using the Write mode as shown in Figure 2. Data is read from the PI3HDMI2410 registers using the Read mode as shown in Figure 3.

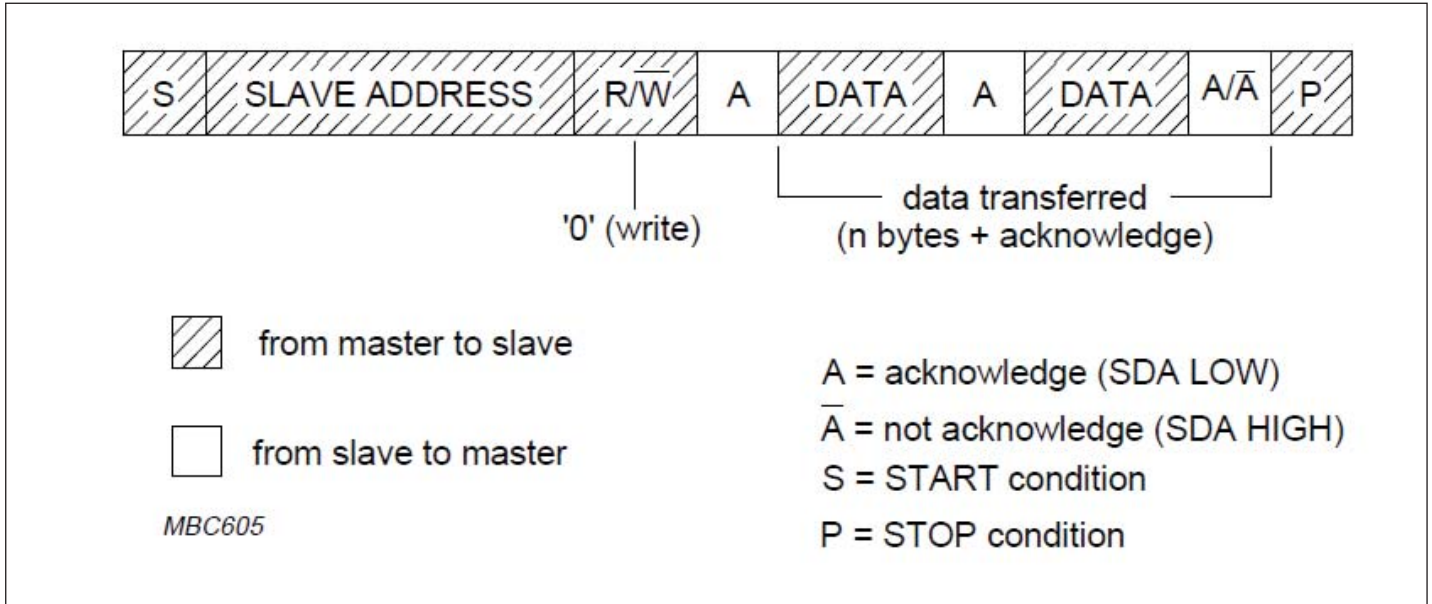

Figure 2 : Write to Control Register

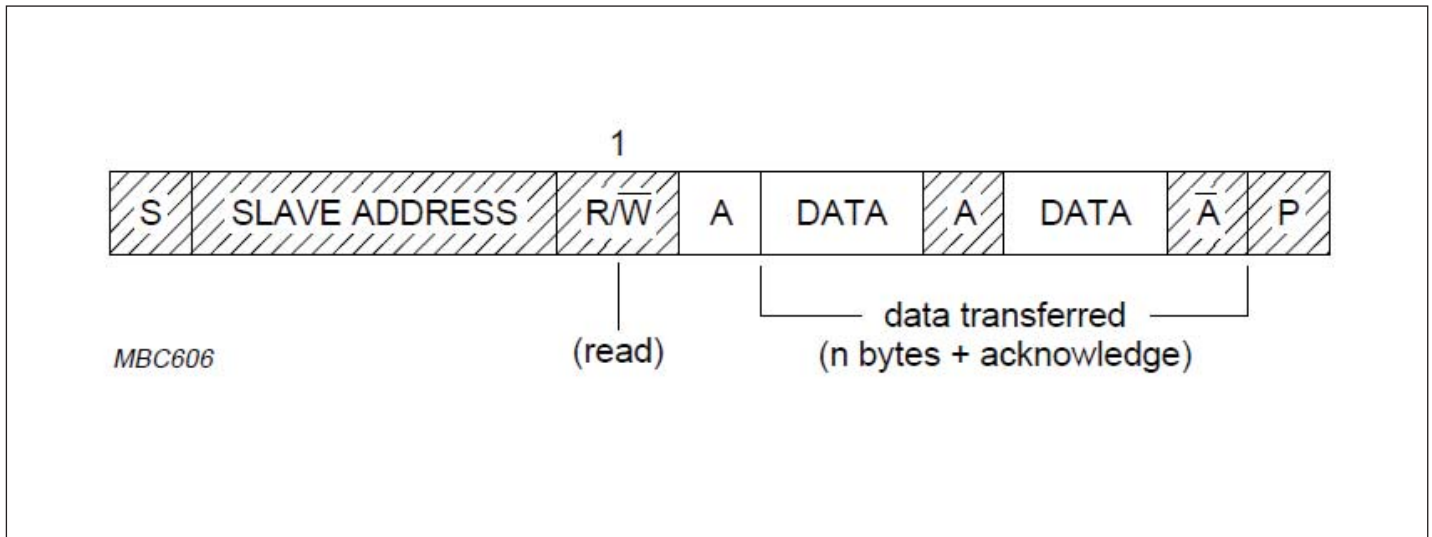
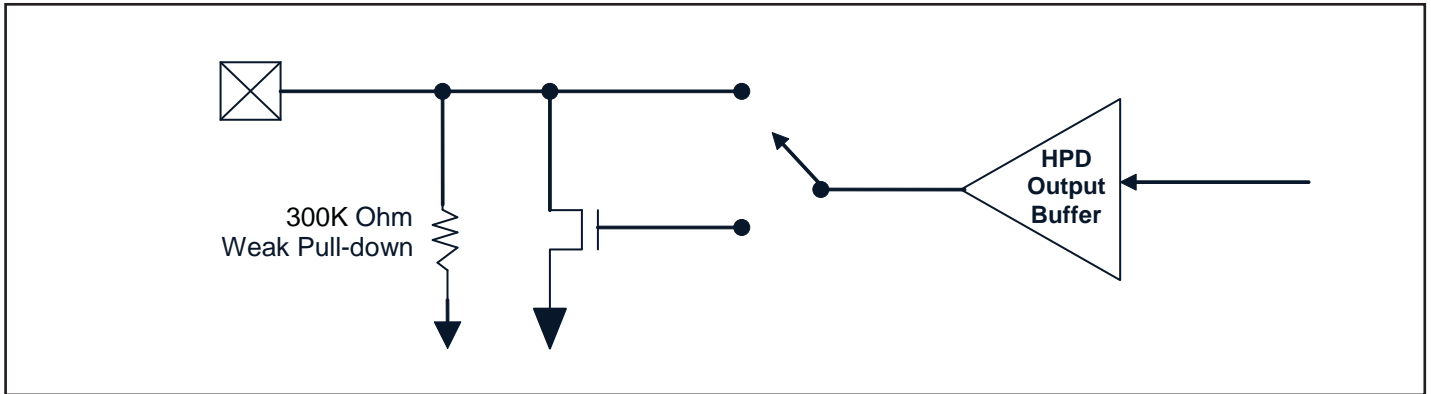

Figure 2 : Read to Control Register

HPD Output Buffer



Data Channel Pull-down Resistor Control

Pull-down resistor active conditions:

1. The Data Channel is unselected
2. Output enable control /OE is disable(/OE=High) or B1b[6]=Low, pull down on all channels
3. No normal operation voltage input (but standby voltage SVDD is still On), pull down on all channels

Output Enable control

Output Disable can be asserted through external \overline{OE} pin or through I²C.

| \overline{OE} | OE_I ² C B1b[6] | Operation |
|-----------------|----------------------------|-----------|
| Low | High | Enable |
| Low | Low | Disable |
| High | X | Disable |

Default value: \overline{OE} = Low ; Byte 1 b[6] = High

Absolute Maximum Ratings (Over operating free-air temperature range)

| Item | Rating |
|------------------------------------|--------------------------------|
| Supply Voltage to Ground Potential | 5.5V |
| All Inputs and Outputs | -0.5V to V _{DD} +0.5V |
| Ambient Operating Temperature | -40 to +85°C |
| Storage Temperature | -65 to +150°C |
| Junction Temperature | 150°C |
| Soldering Temperature | 260°C |

Stress beyond those listed under “Absolute Maximum Ratings” may cause permanent damage to the device.

Recommended Operation Conditions

| Parameter | Min. | Typ. | Max. | Unit |
|---|------|------|------|------|
| Ambient Operating Temperature | -40 | | +85 | °C |
| Power Supply Voltage (measured in respect to GND) | +3.0 | | +3.6 | V |

DC Specifications

V_{DD} = 3.3V ±10%, Ambient Temperature 0 to +70°C

| Symbol | Parameter | Conditions | Min | Nom | Max | Units |
|---------------------|--|--|-----------------------|------|------|-------|
| V _{DD} | Operating Voltage | | 3.0 | 3.3 | 3.6 | V |
| I _{DD} | Supply Current | Output Enable | | 5.0 | 6 | mA |
| I _{DDQ} | Quiescent Supply Current | Output Disable | | 1.7 | 2 | |
| V _{OH_DDC} | DDC passive switch Output High Voltage | Test condition as I _O = 0 (open load), V _I = 5.5V | S _{VDD} -1.0 | | | V |
| V _{OL_DDC} | DDC Buffer Output Low Voltage | Source side, I _{OL} = 3mA External pull-up to 3.3V from 1.5kΩ to 4.7kΩ | | | 0.4 | |
| | | Sink side, I _{OL} = 3mA | 0.65 | 0.75 | 0.95 | |

| Symbol | Parameter | Conditions | Min | Nom | Max | Units |
|--|---|--|------|-----|-----|-------|
| V _{IH_DDC} | DDC Buffer Input High Voltage | Source side (VSEL = 0) | | 1.7 | | V |
| | | Sink side (VSEL = 0) | | 0.5 | | |
| V _{IL_DDC} | DDC Buffer Input Low Voltage | Source side | | | 0.8 | |
| | | Sink side (VSEL = 0) | 0.45 | 0.5 | 0.6 | |
| V _{IH_V5_A'} V _{IH_V5_B'} V _{IH_V5_C'} V _{IH_V5_D'} | Input High Voltage of 5V ports | | 2.4 | | | |
| V _{IL_V5_A'} V _{IL_V5_B'} V _{IL_V5_C'} V _{IL_V5_D'} | Input Low Voltage of 5V ports | | | | 0.8 | |
| V _{OL_HPD} | Buffer Output Low Voltage | I _{OL} = 4 mA | | | 0.4 | |
| | Open Drain Output Low Voltage | I _{OL} = 4 mA | 0 | | 0.4 | |
| V _{OH_HPD} | Buffer Output High Voltage | I _{OH} = 3 mA | 2.4 | | | |
| I _{OFF (HPD)} | Off Leakage Current | V _{DD} = 0V, V _{IN} = 3.6V | | 12 | 20 | μA |
| | | V _{DD} = 0V, V _{IN} = 5.5V | | 20 | 35 | |
| I _{oZ_HPD} | Open Drain Output Leakage Current | V _{DD} = 3.6V, V _{IN} = 3.6V | | 12 | 15 | |
| | | V _{DD} = 3.6V, V _{IN} = 5.5V | | 21 | 38 | |
| V _{OL_DDC_WP} | Open Drain Output Low Voltage | I _{OL} = 4 mA | | | 0.4 | V |
| C _{IO} ¹ | Input/output capacitance (Passive Switch) | V _{DD} = 0V or 3.0V, Frequency = 100kHz | | 6 | 9 | pF |

Note:

1. Measured at V_{bias} = 0V or 5V, V_{rms} = 0.2V;
 V_{bias} = 1.65V, V_{rms} = 0.9V;
 V_{bias} = 2.5V, V_{rms} = 1.2V.

Dynamic Specifications

V_{DD} = 3.3V ±10%, T_A -40 to +85°C, GND = 0V

| Parameter | Description | Conditions | Min | Typ | Max | Units |
|-------------------|--|---------------|-----|-------|-----|-------|
| X _{TALK} | Crosstalk on High-speed Channels | f = 1.13 GHz | | -34 | | dB |
| | | f = 825 GHz | | -36 | | |
| O _{IRR} | OFF Isolation on High-speed Channels | f = 1.13 GHz | | -28 | | |
| | | f = 825 GHz | | -32 | | |
| I _{LOSS} | Defferential Insertion Loss on High-speed Channels | DR = 1.65Gbps | | -1.5 | | dB |
| | | DR = 2.0Gbps | | -1.73 | | |
| | | DR = 2.25Gbps | | -1.82 | | |
| | | DR = 3.0Gbps | | -1.99 | | |
| | | DR = 3.4Gbps | | -2.08 | | |
| BW | -3dB BW for TMDS channels | | | 2.5 | | GHz |

Capacitance Measurement (V_{DD} = 3.3V, T_A =25°C)

| Test Condition | Capacitance | Units |
|----------------|-------------|-------|
| SDA_CTL | 3.0 | pF |
| SCL_CTL | 2.3 | |
| HPD_Sink | 1.7 | |

V_{bias}=0.6V

Packaging Mechanical: 80-Contact LQFP (FF)

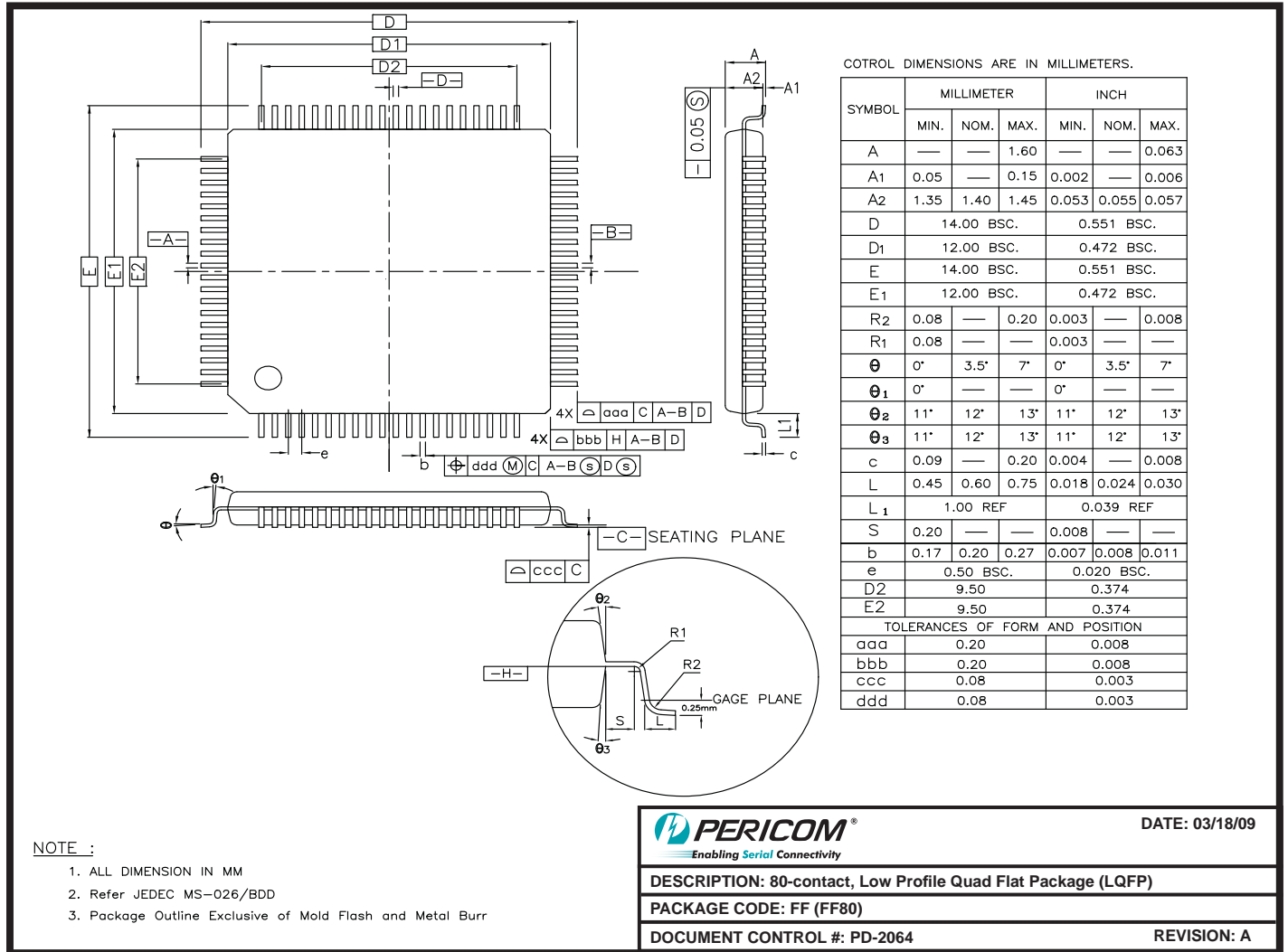

07-0100

Note:

- For latest package info, please check: <http://www.pericom.com/products/packaging/mechanicals.php>

Ordering Information

| Ordering Code | Package Code | Package Type |
|----------------|--------------|-----------------------------------|
| PI3HDMI2410FFE | FF | Pb-free & Green, 80-Contact, LQFP |

1. Thermal characteristics can be found on the company web site at www.pericom.com/packaging/

2. E = Pb-free and Green

3. Adding an X suffix = Tape/Reel

单击下面可查看定价，库存，交付和生命周期等信息

[>>Diodes Incorporated\(达达科技\(美台\)\)](#)