

PI2USB4122

USB 3.0, 4:1 Mux/DeMux Switch

Features

- 2 Differential Channel, 4:1 Mux/DeMux
- USB 3.0 performance, 5.0 Gbps
- Low Bit-to-Bit Skew, 7ps Max.
- Low Crosstalk: -23dB@3GHz
- Low Off Isolation: -23dB@3GHz
- V_{DD} Operating Range: +1.8V+/-10%
- ESD Tolerance 2kV HBM on data I/O
- Packaging (Pb-free & Green):
 - 42 contact TQFN

Description

Diodes' PI2USB4122 is a 4 to 1 differential channel multiplexer/demultiplexer switch. Due to its low bit-to-bit skew, high channel-to-channel noise isolation and high bandwidth, this product is ideal for USB 3.0 switching to 5.0 Gbps.

Application

Switching USB 3.0 signals for Mux or DeMux.

Block Diagram

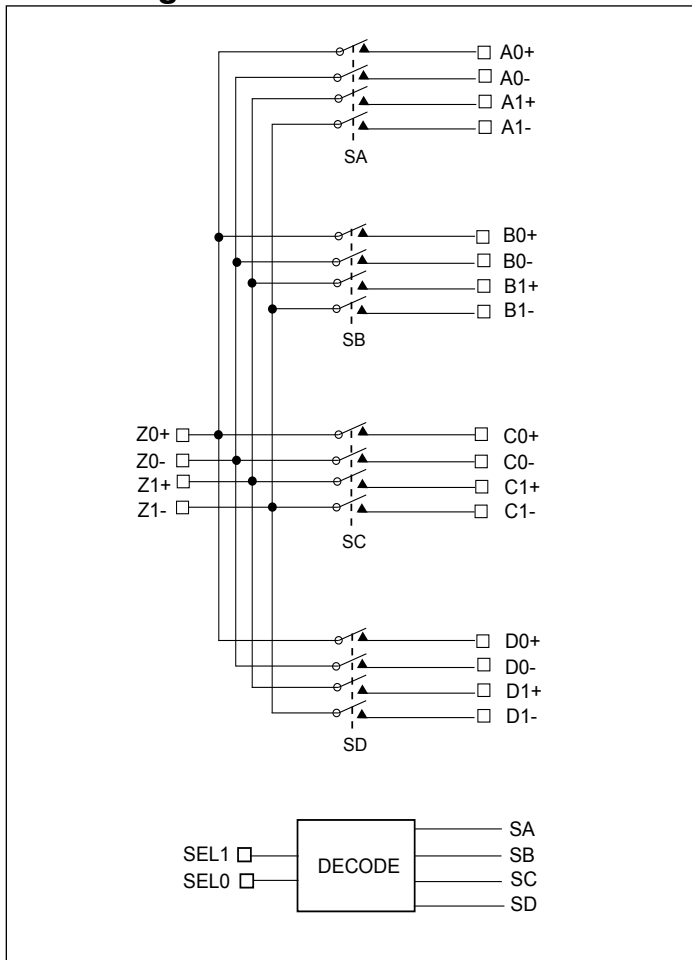

Pin Description

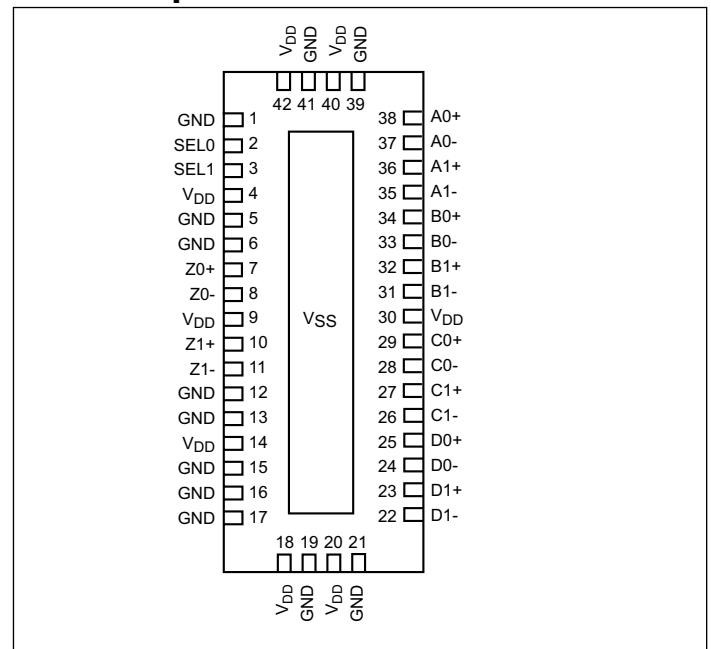

Truth Table

SEL1	SEL0	FUNCTION
0	0	Z to A
0	1	Z to B
1	0	Z to C
1	1	Z to D

Maximum Ratings

(Above which useful life may be impaired. For user guidelines, not tested.)

Storage Temperature	-65°C to +150°C
Supply Voltage to Ground Potential	-0.5V to +2.5V
DC Input Voltage	-0.5V to +V _{DD}
DC Output Current	120mA
Power Dissipation	0.5W

Note: Stresses greater than those listed under MAXIMUM RATINGS may cause permanent damage to the device. This is a stress rating only and functional operation of the device at these or any other conditions above those indicated in the operational sections of this specification is not implied. Exposure to absolute maximum rating conditions for extended periods may affect reliability.

Power Supply Characteristics

Parameters	Description	Test Conditions ⁽¹⁾	Min.	Typ. ⁽²⁾	Max.	Units
I _{CC}	Quiescent Power Supply Current	V _{DD} = Max, V _{IN} = GND or V _{DD}		200	300	μA

Notes:

- For Max. or Min. conditions, use appropriate value specified under Electrical Characteristics for the applicable device type.
- Typical values are at V_{DD} = 1.8V, T_A = 25°C ambient and maximum loading.

DC Electrical Characteristics for Switching over Operating Range

(T_A = -40°C to +85°C, V_{DD} = 1.8V +/- 10%)

Parameter	Description	Test Conditions	Min.	Typ. ⁽²⁾	Max.	Units
V _{IH}	Input HIGH Voltage	Guaranteed HIGH level	0.65 x V _{DD}	-	-	V
V _{IL}	Input LOW Voltage	Guaranteed LOW level	-	-	0.35 x V _{DD}	
V _{IK}	Clamp Diode Voltage	V _{DD} = Max., I _{IN} = -18mA	-	-0.7	-1.2	
I _{IH}	Input HIGH Current	V _{DD} = Max., V _{IN} = V _{DD}	-	-	±5	μA
I _{IL}	Input LOW Current	V _{DD} = Max., V _{IN} = GND	-	-	±5	

Switching Characteristics (T_A = -40° to +85°C, V_{DD} = 1.8V +/- 10%)

Parameter	Description	Min.	Typ. ⁽²⁾	Max.	Units
t _{PZH} , t _{PZL}	Line Enable Time - SEL to A _N , B _N	0.5	-	8.0	ns
t _{PHZ} , t _{PLZ}	Line Disable Time - SEL to A _N , B _N	0.5	-	10	
t _{b-b}	Bit-to-bit skew within the same differential pair		7		ps
t _{ch-ch}	Channel-to-channel skew		35		ps

Notes:

- For max. or min. conditions, use appropriate value specified under Electrical Characteristics for the applicable device type.

Dynamic Electrical Characteristics Over the Operating Range

(T_A = -40° to +85°C, V_{DD} = 1.8V +/- 10%)

Parameter	Description	Test Conditions ⁽¹⁾	Min.	Typ. ⁽²⁾	Max.	Units
X _{TALK}	Crosstalk	f = 2.5 GHz		-40		dB
O _{IRR}	OFF Isolation	f = 2.5 GHz		-25		dB
I _{LOSS}	Differential Insertion Loss	f = 2.5 GHz		-3.0		dB
BW	Bandwidth -3dB			2.6		GHz

Notes:

- Guaranteed by design.
- Typical values are at V_{DD} = 1.8V, T_A = 25°C ambient and maximum loading.

PI2USB4122

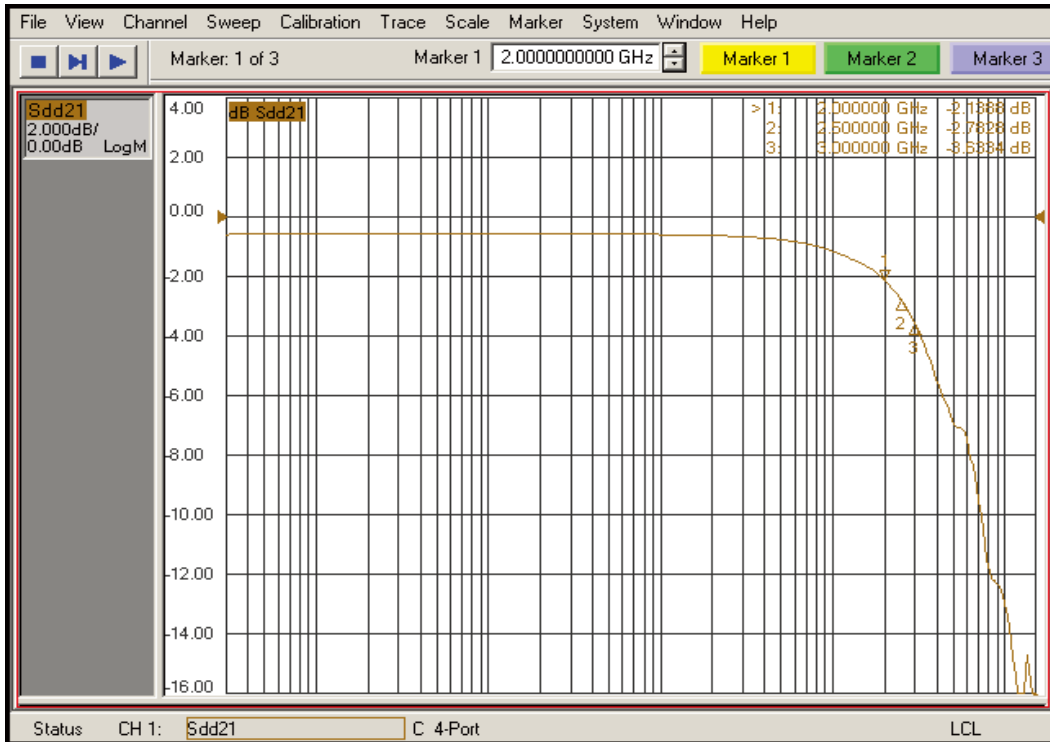

Insertion Loss

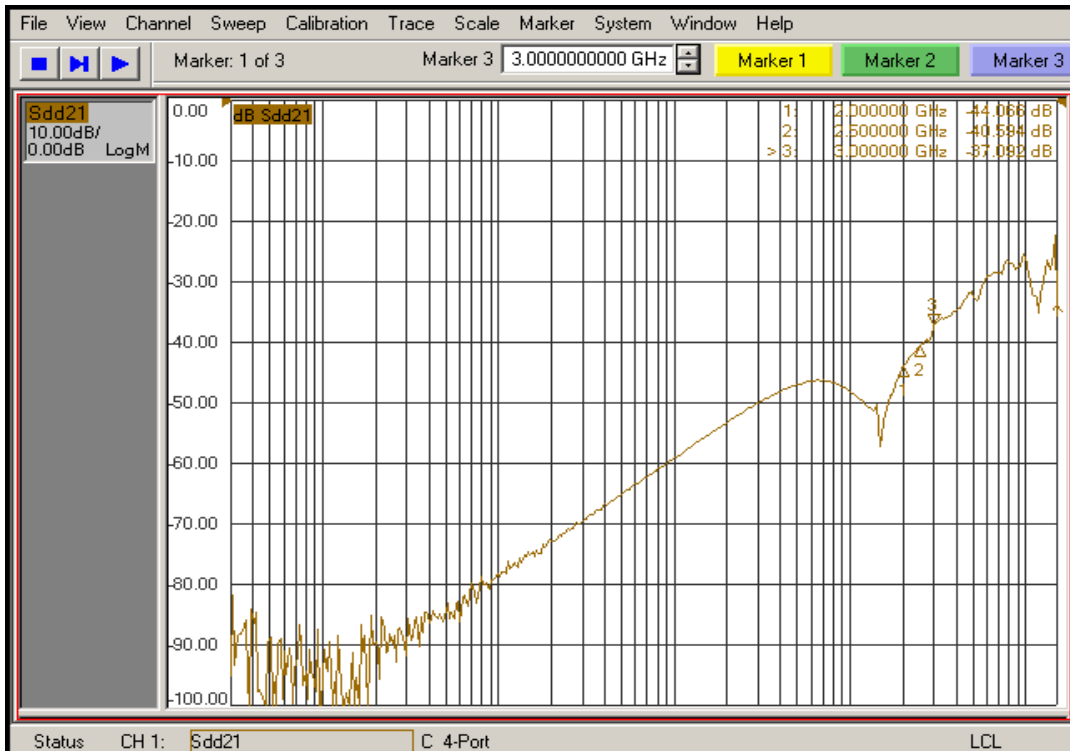

Crosstalk

PI2USB4122

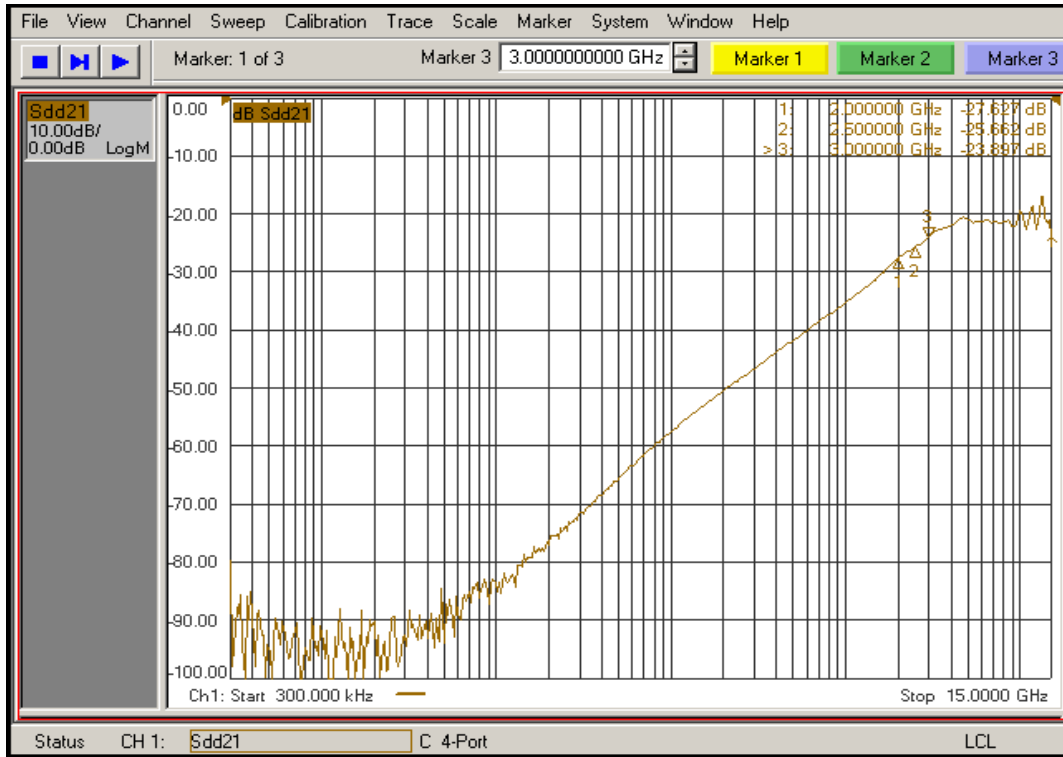

Off Isolation

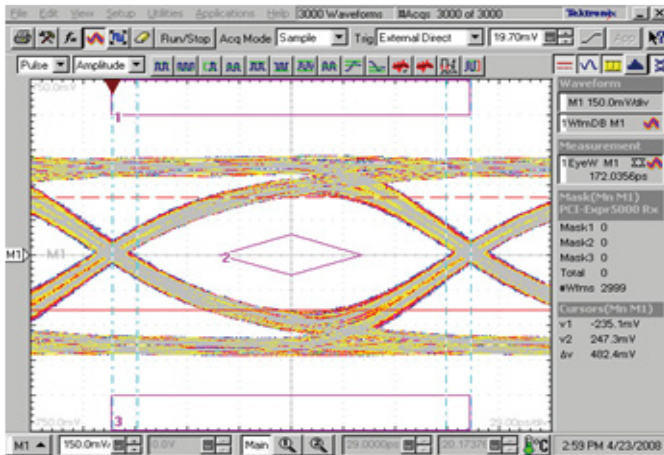

Signal Eye with Switch

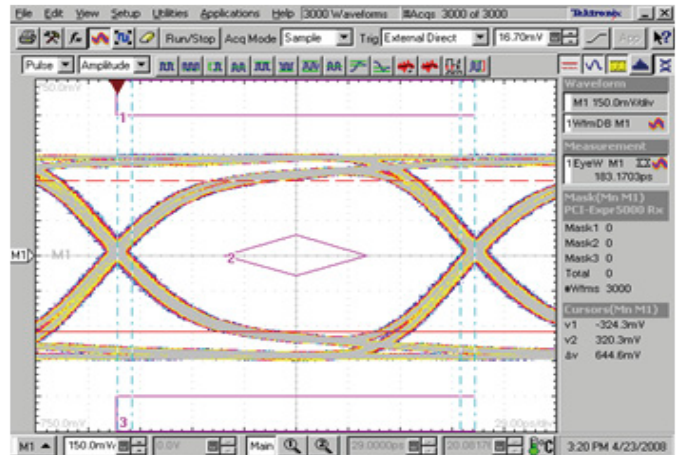

Signal Eye without Switch

PI2USB4122

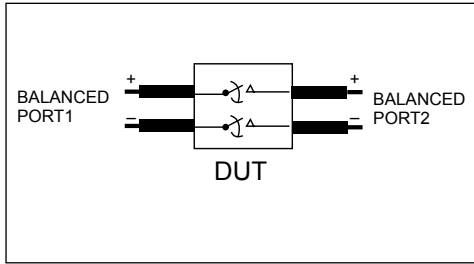

Diff. Insertion Loss and Return Test Circuit

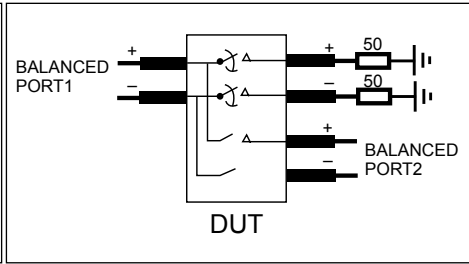

Diff. Off Isolation Test Circuit

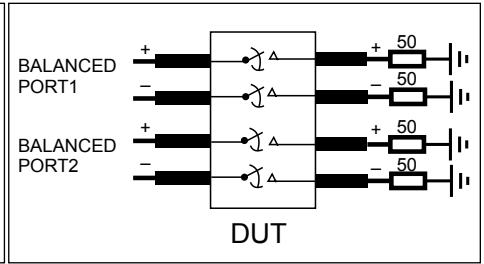

Diff. Near End Xtalk Test Circuit

Test Circuit for Electrical Characteristics⁽¹⁻⁵⁾

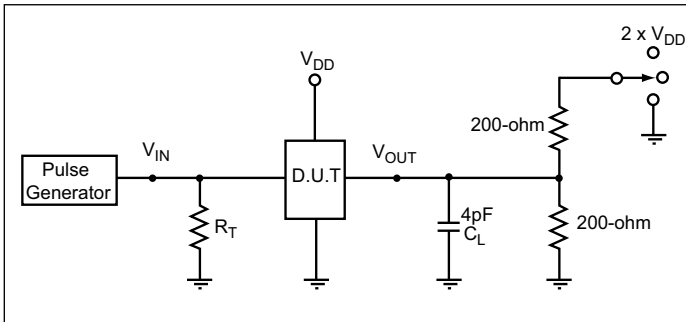

Notes:

1. C_L = Load capacitance: includes jig and probe capacitance.
2. R_T = Termination resistance: should be equal to Z_{OUT} of the Pulse Generator
3. Output 1 is for an output with internal conditions such that the output is low except when disabled by the output control.
output 2 is for an output with internal conditions such that the output is high except when disabled by the output control.
4. All input impulses are supplied by generators having the following characteristics: $PRR \leq 1$ MHz, $Z_O = 50\Omega$, $t_r \leq 2.5$ ns, $t_f \leq 2.5$ ns.
5. The outputs are measured one at a time with one transition per measurement.

Switch Positions

Test	Switch
t_{PLZ} , t_{PZL}	$2 \times V_{DD}$
t_{PHZ} , t_{PZH}	GND
Prop Delay	Open

Switching Waveforms

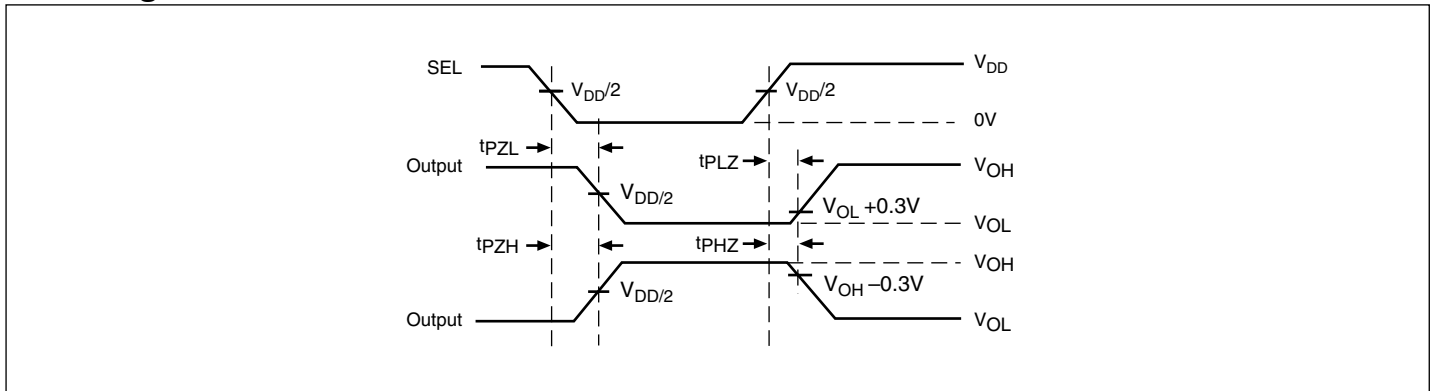

Voltage Waveforms Enable and Disable Times

PI2USB4122

Package Mechanical: 42-TQFN (ZH)

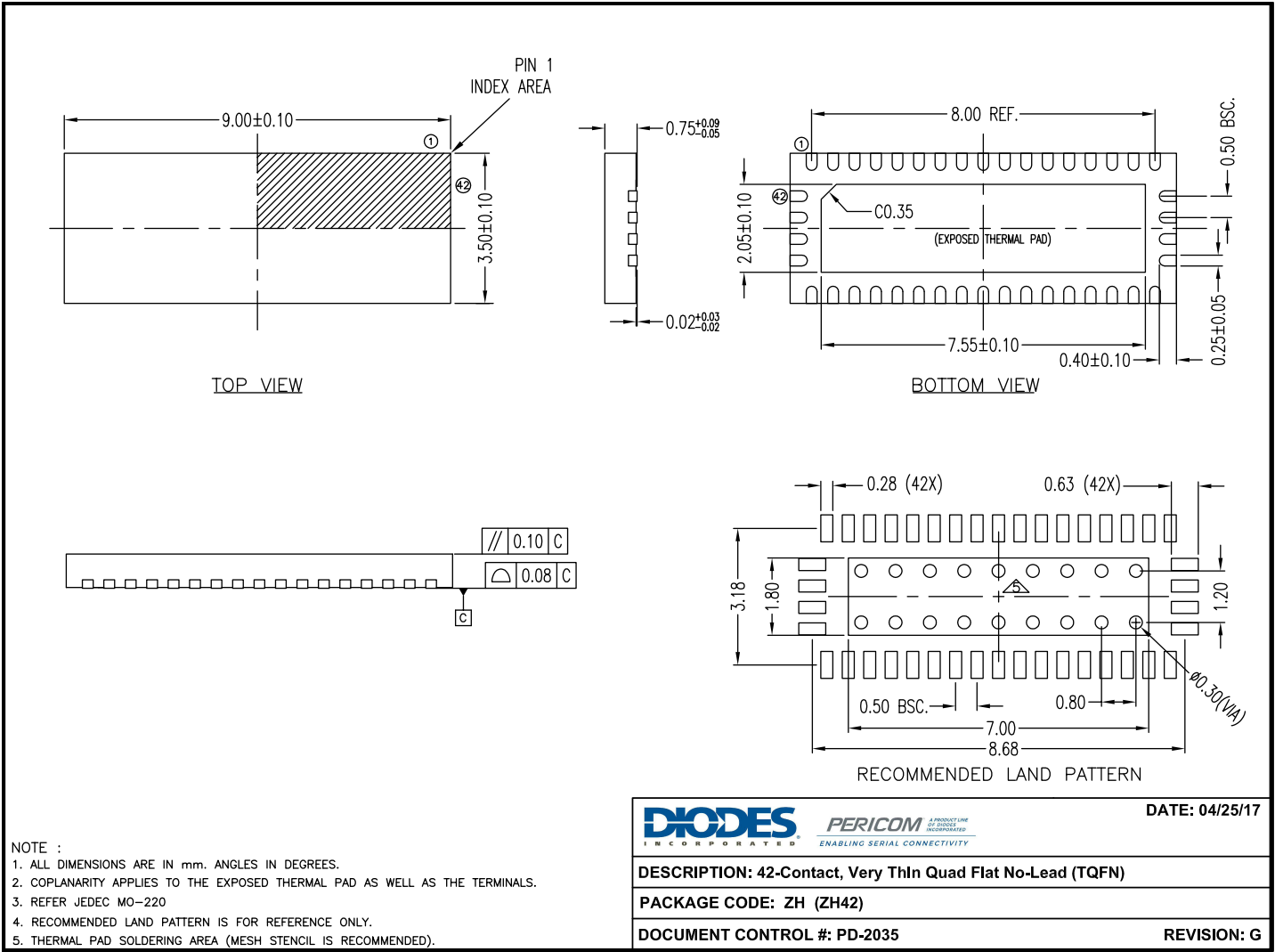

17-0266

For latest package info.

please check: <http://www.diodes.com/design/support/packaging/pericom-packaging/packaging-mechanicals-and-thermal-characteristics/>

Ordering Information

Ordering Code	Package Code	Package Type
PI2USB4122ZHEX	ZH	42-Contact, Very Thin Quad Flat No-Lead (TQFN)

Notes:

- Thermal characteristics can be found on the company web site at www.diodes.com/design/support/packaging/
- E = Pb-free and Green
- X suffix = Tape/Reel

IMPORTANT NOTICE

DIODES INCORPORATED MAKES NO WARRANTY OF ANY KIND, EXPRESS OR IMPLIED, WITH REGARDS TO THIS DOCUMENT, INCLUDING, BUT NOT LIMITED TO, THE IMPLIED WARRANTIES OF MERCHANTABILITY AND FITNESS FOR A PARTICULAR PURPOSE (AND THEIR EQUIVALENTS UNDER THE LAWS OF ANY JURISDICTION).

Diodes Incorporated and its subsidiaries reserve the right to make modifications, enhancements, improvements, corrections or other changes without further notice to this document and any product described herein. Diodes Incorporated does not assume any liability arising out of the application or use of this document or any product described herein; neither does Diodes Incorporated convey any license under its patent or trademark rights, nor the rights of others. Any Customer or user of this document or products described herein in such applications shall assume all risks of such use and will agree to hold Diodes Incorporated and all the companies whose products are represented on Diodes Incorporated website, harmless against all damages.

Diodes Incorporated does not warrant or accept any liability whatsoever in respect of any products purchased through unauthorized sales channel.

Should Customers purchase or use Diodes Incorporated products for any unintended or unauthorized application, Customers shall indemnify and hold Diodes Incorporated and its representatives harmless against all claims, damages, expenses, and attorney fees arising out of, directly or indirectly, any claim of personal injury or death associated with such unintended or unauthorized application.

Products described herein may be covered by one or more United States, international or foreign patents pending. Product names and markings noted herein may also be covered by one or more United States, international or foreign trademarks.

This document is written in English but may be translated into multiple languages for reference. Only the English version of this document is the final and definitive format released by Diodes Incorporated.

LIFE SUPPORT

Diodes Incorporated products are specifically not authorized for use as critical components in life support devices or systems without the express written approval of the Chief Executive Officer of Diodes Incorporated. As used herein:

A. Life support devices or systems are devices or systems which:

1. are intended to implant into the body, or
2. support or sustain life and whose failure to perform when properly used in accordance with instructions for use provided in the labeling can be reasonably expected to result in significant injury to the user.

B. A critical component is any component in a life support device or system whose failure to perform can be reasonably expected to cause the failure of the life support device or to affect its safety or effectiveness.

Customers represent that they have all necessary expertise in the safety and regulatory ramifications of their life support devices or systems, and acknowledge and agree that they are solely responsible for all legal, regulatory and safety-related requirements concerning their products and any use of Diodes Incorporated products in such safety-critical, life support devices or systems, notwithstanding any devices- or systems-related information or support that may be provided by Diodes Incorporated. Further, Customers must fully indemnify Diodes Incorporated and its representatives against any damages arising out of the use of Diodes Incorporated products in such safety-critical, life support devices or systems.

Copyright © 2016, Diodes Incorporated
www.diodes.com

单击下面可查看定价，库存，交付和生命周期等信息

[>>Diodes Incorporated\(达达科技\(美台\)\)](#)