

Description

The PAM8304 is a mono, filter-less, Class-D amplifier with high SNR and differential input that helps eliminate noise. The PAM8304 supports 2.8V to 6V operation, which makes it ideal for up to 4-cell alkaline battery applications. The PAM8304 is capable of driving speaker loads as low as 3Ω with a 5V supply, maximizing the output power.

The device's over 90% efficiency and small PCB area make the PAM8304 Class-D amplifier ideal for portable applications. The output uses a filter-less architecture, minimizing the number of external components in the PCB area whilst providing a high-performance, simple, and lower cost system.

The PAM8304 features short circuit protection, thermal shutdown, and undervoltage lock-out.

The PAM8304 is available in the U-DFN3030-8 and MSOP-8 packages.

Features

- Supply Voltage from 2.8V to 6.0 V
- 3Ω Driving Capability
- 3.0W@10% THD Output with a 4Ω Load and 5V Supply
- High Efficiency up to 90% @1W with an 8Ω Load
- Shutdown Current <1μA
- Superior Low Noise without Input
- Short Circuit Protection
- Thermal Shutdown
- Available in Space-Saving U-DFN3030-8 and MSOP-8L Packages
- Pb-Free Package
- **For automotive applications requiring specific change control (i.e. parts qualified to AEC-Q100/101/200, PPAP capable, and manufactured in IATF 16949 certified facilities), please [contact us](https://www.diodes.com/contact-us) or your local Diodes representative. <https://www.diodes.com/quality/product-definitions/>**

Pin Assignments

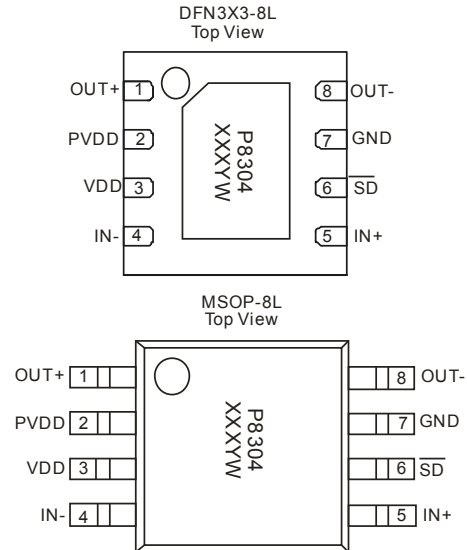

Applications

- MP4/MP3
- GPS
- Set-Top-Box
- Tablets/Digital Photo Frame
- Electronic Dictionary
- Portable Game Machines

Typical Applications Circuit

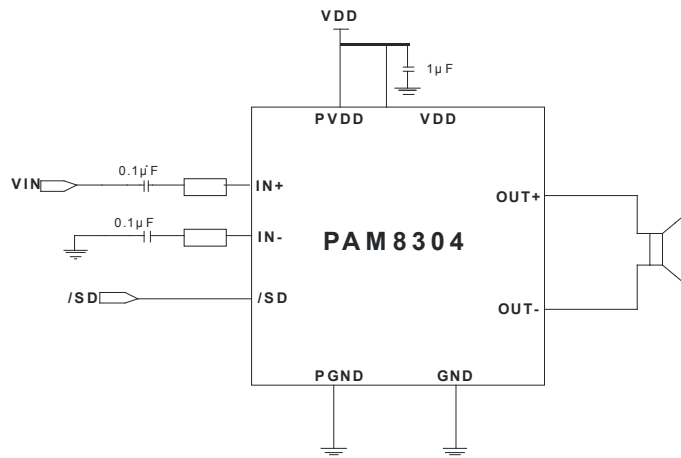

Pin Descriptions

Pin Name	MSOP-8/ U-DFN3030-8	Function
OUT+	1	Positive BTL Output
PVDD	2	Power Supply
VDD	3	Analog Power Supply
IN-	4	Negative Differential Input
IN+	5	Positive Differential Input
/SD	6	Shutdown Terminal, Active Low
GND	7	Ground
OUT-	8	Negative BTL Output
Exposed Pad	—	NC

Functional Block Diagram

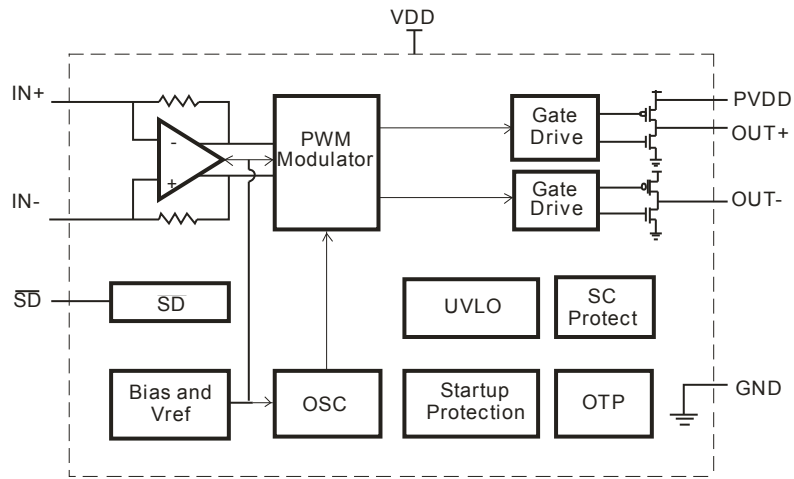

Absolute Maximum Ratings (@ T_A = +25°C, unless otherwise specified.)

Parameter	Rating	Unit
Supply Voltage (V _{DD})	6.5	V
Input Voltage (IN+, IN-, /SD)	-0.3 to V _{DD} + 0.3	V
Storage Temperature	-65 to +150	°C
Maximum Junction Temperature	150	°C

Recommended Operating Conditions (@ T_A = +25°C, unless otherwise specified.)

Symbol	Parameter	Min	Max	Unit
V _{DD}	Supply Voltage	2.8	6.0	V
T _A	Operating Ambient Temperature Range	-40	+85	°C
T _J	Junction Temperature Range	-40	+125	°C

Electrical Characteristics (@ $T_A = +25^\circ\text{C}$, $V_{DD} = 5\text{V}$, Gain = 18dB, $R_L = L(33\mu\text{H}) + R + L(33\mu\text{H})$, unless otherwise noted.)

Symbol	Parameter	Test Conditions		Min	Typ	Max	Unit
VDD	Supply Voltage	—		2.8	—	6.0	V
Po	Output Power	THD+N = 10%, f = 1kHz, R = 4Ω	VDD = 5.0V	—	3.0	—	W
			VDD = 3.6V	—	1.5	—	
			VDD = 3.2V	—	1.2	—	
		THD+N = 1%, f = 1kHz, R = 4Ω	VDD = 5.0V	—	2.4	—	W
			VDD = 3.6V	—	1.25	—	
			VDD = 3.2V	—	1.0	—	
		THD+N = 10%, f = 1kHz, R = 8Ω	VDD = 5.0V	—	1.75	—	W
			VDD = 3.6V	—	0.90	—	
			VDD = 3.2V	—	0.70	—	
		THD+N = 1%, f = 1kHz, R = 8Ω	VDD = 5.0V	—	1.40	—	W
			VDD = 3.6V	—	0.72	—	
			VDD = 3.2V	—	0.60	—	
THD+N	Total Harmonic Distortion Plus Noise	f = 1kHz	VDD = 5.0V, Po = 1W, R = 8Ω	—	0.17	—	%
			VDD = 3.6V, Po = 0.1W, R = 8Ω	—	0.16	—	
			VDD = 3.2V, Po = 0.1W, R = 8Ω	—	0.14	—	
		f = 1kHz	VDD = 5.0V, Po = 0.5W, R = 4Ω	—	0.14	—	%
			VDD = 3.6V, Po = 0.2W, R = 4Ω	—	0.16	—	
			VDD = 3.2V, Po = 0.1W, R = 4Ω	—	0.17	—	
PSRR	Power Supply Ripple Rejection	VDD = 3.6V, Inputs ac-grounded with C = 1μF	f=217Hz	—	-68	—	dB
			f=1kHz	—	-70	—	
			f=10kHz	—	-67	—	
Dyn	Dynamic Range	VDD = 5V, THD = %, R = 8Ω	f=1kHz	—	95	—	dB
Vn	Output Noise	Inputs ac-grounded	No A weighting	—	170	—	μV
			A-weighting	—	130	—	
η	Efficiency	RL = 8Ω, THD = 10%	f=1kHz	—	93	—	%
		RL = 4Ω, THD = 10%		—	86	—	
IQ	Quiescent Current	VDD = 5V	No Load	—	5	—	mA
I _{sd}	Shutdown Current	VDD = 2.8V to 5V	/SD=0V	—	—	1	μA
R _{dson}	Static Drain-to Source On-state Resistor	High-Side PMOS, I = 500mA	VDD=5.0V	—	325	—	mΩ
		Low-Side NMOS, I = 500mA	VDD=5.0V	—	200	—	mΩ
f _{sw}	Switching Frequency	VDD = 2.8V to 5V	—	—	400	—	kHz
G _v	Closed-Loop Gain	VDD = 2.8V to 5V	—	—	300K/R _{in}	—	V/V
V _{os}	Output Offset Voltage	Input ac-ground, VDD = 5V	—	—	—	50	mV
V _{IH}	SD Input High Voltage	VDD = 5V	—	1.4	—	—	V
V _{IL}	SD Input Low Voltage	VDD = 5V	—	—	—	0.4	

Performance Characteristics (continued) (@ $T_A = +25^\circ\text{C}$, $V_{DD} = 5\text{V}$, Gain = 18dB, $R_L = L(33\mu\text{H}) + R + L(33\mu\text{H})$, unless otherwise noted.)

THD+N Vs. Output Power (RL=4Ω)

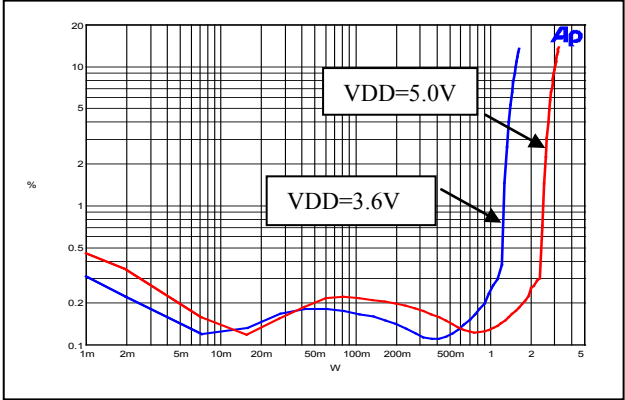

THD+N Vs. Output Power (RL=8Ω)

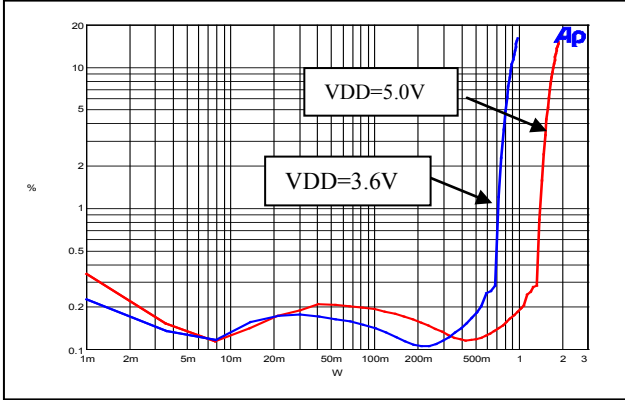

THD+N Vs. Frequency

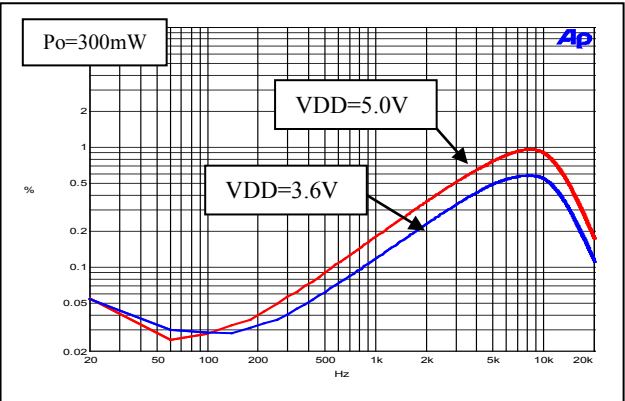

PSRR Vs. Frequency

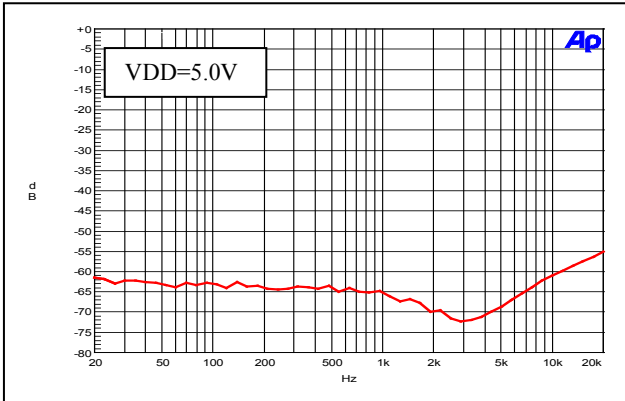

Frequency Response

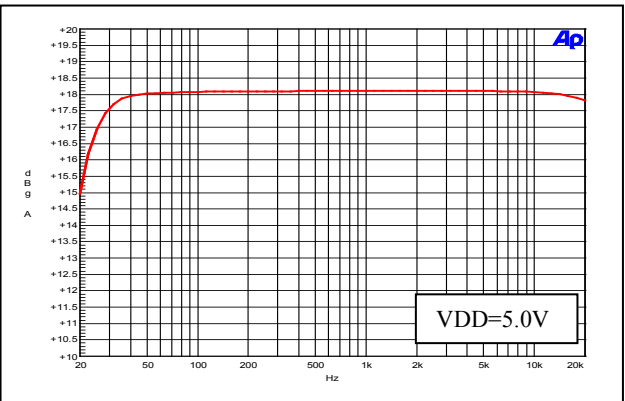

Noise Floor

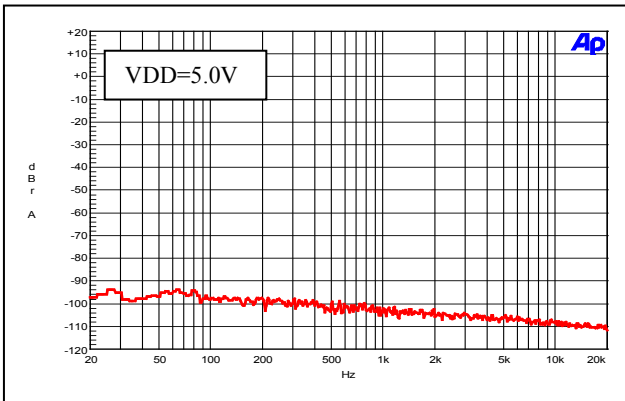

Performance Characteristics (@ $T_A = +25^\circ\text{C}$, $V_{DD} = 5\text{V}$, Gain = 18dB, $R_L = L(33\mu\text{H}) + R + L(33\mu\text{H})$, unless otherwise noted.)

Efficiency Vs. Output Power (RL=4Ω)

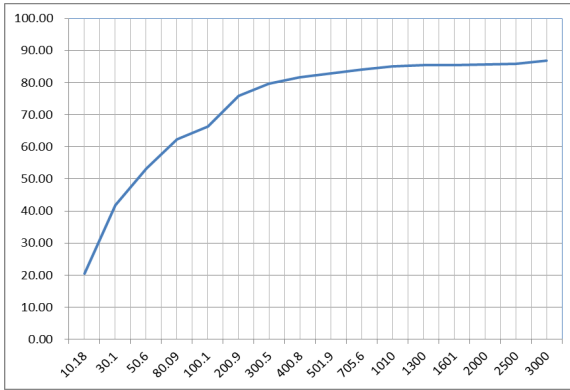

Efficiency Vs. Output Power (RL=8Ω)

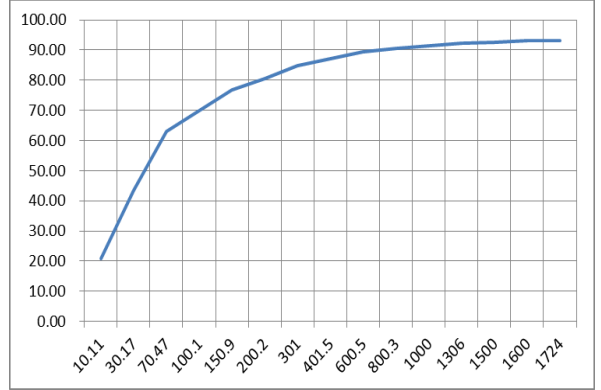

Quiescent Current Vs. Supply Voltage

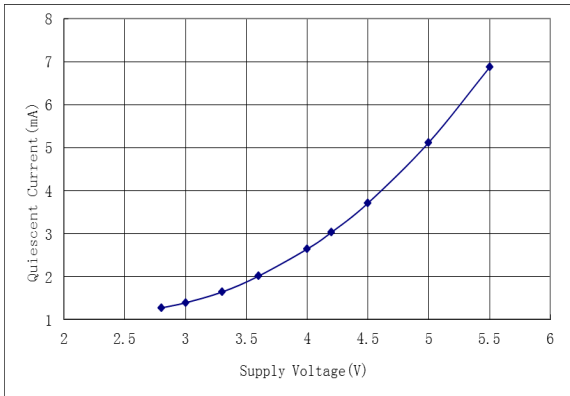

OSC Frequency Vs. Supply Voltage

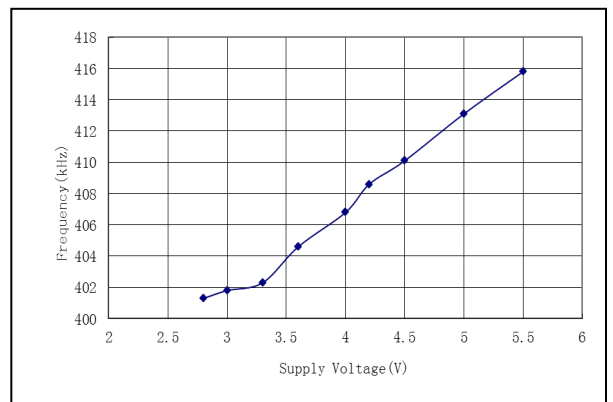

Start-up Response

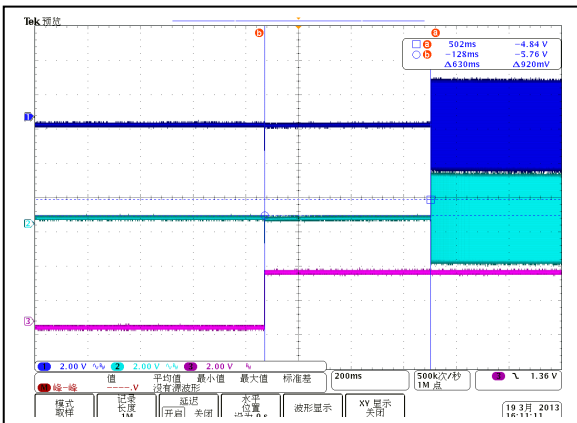

Shutdown Response

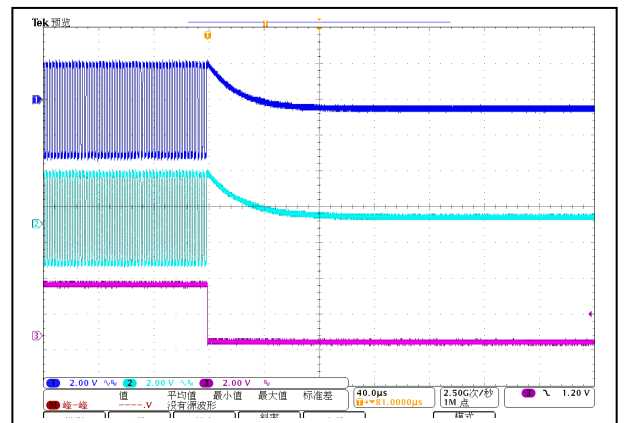

Application Information

Input Capacitors (Ci)

In typical application, an input capacitor Ci is required to allow the amplifier to bias the input signal to the proper DC level for optimum operation. In this case, Ci and the minimum input impedance Ri form a high-pass filter with the corner frequency determined in the follow equation:

$$f_c = \frac{1}{(2\pi R_i C_i)}$$

It is important to consider the value of Ci as it directly affects the low frequency performance of the circuit. For example, when Ri is 150kΩ and the specification calls for a flat bass response down to 150Hz. The equation is reconfigured as followed to determine the value of Ci:

$$C_i = \frac{1}{(2\pi R_i f_c)}$$

When input resistance variation is considered, if Ci is 7nF, one would likely choose a value of 10nF. A further consideration for this capacitor is the leakage path from the input source through the input network (Ci, Ri, and Rf) to the load. This leakage current creates a DC offset voltage at the input to the amplifier and reduces useful headroom, especially in high-gain applications. For this reason, a low-leakage tantalum or ceramic capacitor is recommended. When polarized capacitors are used, the positive side of the capacitor should face the amplifier input in most applications as the DC level is held at VDD/2, which is likely higher than the source DC level. Please note that it is important to confirm the capacitor polarity in the application.

Decoupling Capacitor (CS)

The PAM8304 is a high-performance CMOS audio amplifier that requires adequate power supply decoupling to ensure the output total harmonic distortion (THD) is as low as possible. Power supply decoupling also prevents oscillations caused by long lead length between the amplifier and the speaker.

Optimum decoupling is achieved by using two different types of capacitors that target different types of noise on the power supply leads. Higher frequency transients, spikes, or digital hashes should be filtered with a good low equivalent-series-resistance (ESR) ceramic capacitor with a value of typically 1μF. This capacitor should be placed as close as possible to the VDD pin of the device. Lower frequency noise signals should be filtered with a large ceramic capacitor of 10μF or greater. It is recommended to place this capacitor near the audio power amplifier.

How to Reduce EMI

Most applications require a ferrite bead filter for EMI elimination, as shown in Figure 1. The ferrite filter reduces EMI around 1MHz and higher. When selecting a ferrite bead, it should be chosen with consideration to high impedance at high frequencies and low impedance at low frequencies.

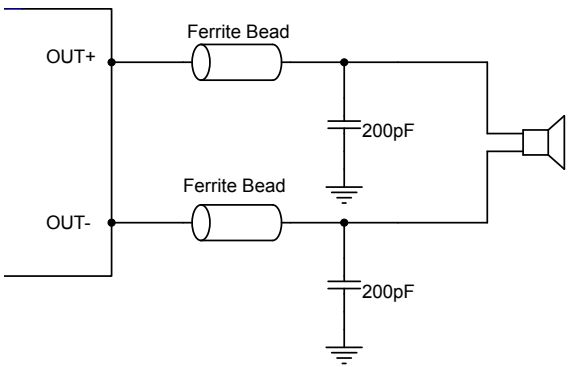

Figure 1 Ferrite Bead Filter to Reduce EMI

Application Information (continued)

Shutdown Operation

The PAM8304 contains amplifier shutdown circuitry in order to reduce power consumption while not in use. When a logic low or ground is applied to the /SD pin, the PAM8304 will enter a standby mode and supply current drawn will be minimized.

Undervoltage Lock-Out (UVLO)

The PAM8304 incorporates circuitry designed to detect low supply voltage. When the supply voltage drops to 2.5V or below, the PAM8304 goes into a state of shutdown. The device returns to normal operation only when VDD is higher than 2.8V.

Short Circuit Protection (SCP)

The PAM8304 has short circuit protection circuitry on the outputs to prevent the device from damage when output-to-output shorts or output-to-GND shorts occur. When a short circuit occurs, the device immediately goes into shutdown state. Once the short is removed the device will be reactivated.

Overtemperature Protection (OTP)

Thermal protection prevents the device from damage. When the internal die temperature exceeds a typical of 150°C the device will enter a shutdown state and the outputs are disabled. This is not a latched fault, once the thermal fault is cleared and the temperature of the die decreases by 40°C, the device will restart with no external system interaction.

Anti-Pop and Anti-Click Circuitry

The PAM8304 contains circuitry to minimize turn-on and turn-off transients or “click and pops”, where turn-on refers to either power supply turn-on or device recovery from shutdown mode. When the device is turned on, the amplifiers are internally muted. An internal current source ramps up the internal reference voltage. The device will remain in mute mode until the reference voltage reaches half-supply voltage. As soon as the reference voltage is stable, the device will begin full operation. For the best power-off pop performance, the amplifier should be set in shutdown mode prior to removing the power supply voltage.

Ordering Information

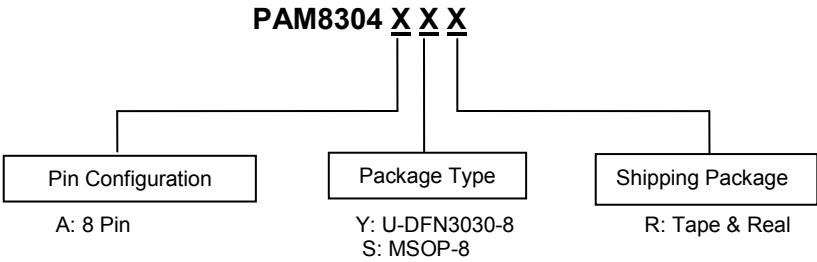

Part Number	Package	Standard Package
PAM8304AYR	U-DFN3030-8	3,000Units/Tape&Real
PAM8304ASR	MSOP-8	2,500Units/Tape&Real

Marking Information

U-DFN3030-8

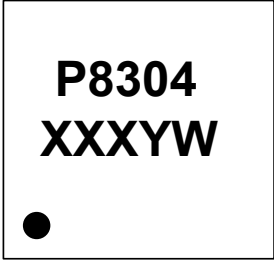

MSOP-8

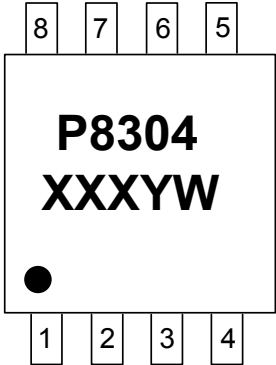

P8304: Product Code
 X : Internal Code
 Y : Year : 0 to 9
 W : Week : A to Z : 1 to 26 week;
 a to z : 27 to 52 week; z represents
 52 and 53 week

Package Outline Dimensions

Please see <http://www.diodes.com/package-outlines.html> for the latest version.

U-DFN3030-8 (Type E)

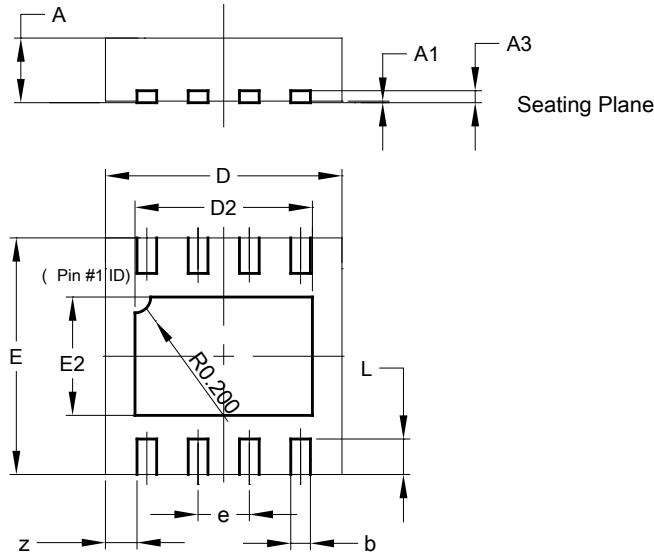

U-DFN3030-8 (Type E)			
Dim	Min	Max	Typ
A	0.57	0.63	0.60
A1	0.00	0.05	0.02
A3	-	-	0.15
b	0.20	0.30	0.25
D	2.95	3.05	3.00
D2	2.15	2.35	2.25
E	2.95	3.05	3.00
E2	1.40	1.60	1.50
e	-	-	0.65
L	0.30	0.60	0.45
z	-	-	0.40
All Dimensions in mm			

MSOP-8

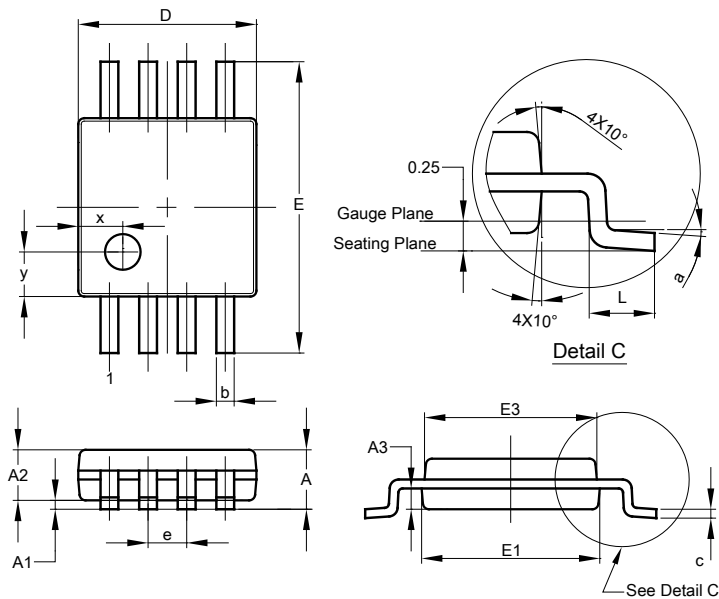

MSOP-8			
Dim	Min	Max	Typ
A	-	1.10	-
A1	0.05	0.15	0.10
A2	0.75	0.95	0.86
A3	0.29	0.49	0.39
b	0.22	0.38	0.30
c	0.08	0.23	0.15
D	2.90	3.10	3.00
E	4.70	5.10	4.90
E1	2.90	3.10	3.00
E3	2.85	3.05	2.95
e	-	-	0.65
L	0.40	0.80	0.60
a	0°	8°	4°
x	-	-	0.750
y	-	-	0.750
All Dimensions in mm			

Suggested Pad Layout

Please see <http://www.diodes.com/package-outlines.html> for the latest version.

U-DFN3030-8 (Type E)

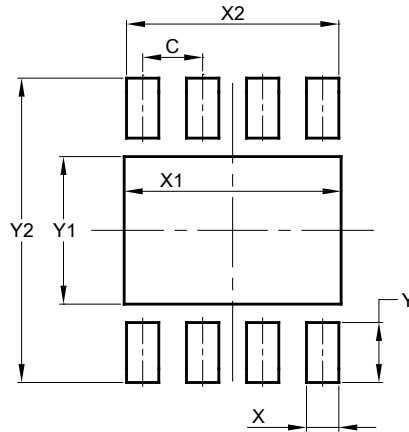

Dimensions	Value (in mm)
C	0.650
X	0.350
X1	2.350
X2	2.300
Y	0.650
Y1	1.600
Y2	3.300

MSOP-8

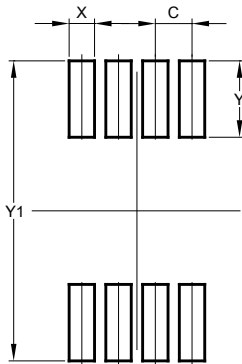

Dimensions	Value (in mm)
C	0.650
X	0.450
Y	1.350
Y1	5.300

Mechanical Data

MSOP-8

- Moisture Sensitivity: Level 3 per J-STD-020
- Terminals: Finish – Matte Tin Plated Leads, Solderable per MIL-STD-202, Method 208 **(e3)**
- Weight: 0.027 grams (Approximate)

U-DFN3030-8 (Type E)

- Moisture Sensitivity: Level 1 per J-STD-020
- Terminals: Finish – NiPdAu, Solderable per J-STD-002, Test B1 **(e4)**
- Weight: 0.018 grams (Approximate)

IMPORTANT NOTICE

1. DIODES INCORPORATED AND ITS SUBSIDIARIES (“DIODES”) MAKE NO WARRANTY OF ANY KIND, EXPRESS OR IMPLIED, WITH REGARDS TO ANY INFORMATION CONTAINED IN THIS DOCUMENT, INCLUDING, BUT NOT LIMITED TO, THE IMPLIED WARRANTIES OF MERCHANTABILITY, FITNESS FOR A PARTICULAR PURPOSE OR NON-INFRINGEMENT OF THIRD PARTY INTELLECTUAL PROPERTY RIGHTS (AND THEIR EQUIVALENTS UNDER THE LAWS OF ANY JURISDICTION).
2. The Information contained herein is for informational purpose only and is provided only to illustrate the operation of Diodes products described herein and application examples. Diodes does not assume any liability arising out of the application or use of this document or any product described herein. This document is intended for skilled and technically trained engineering customers and users who design with Diodes products. Diodes products may be used to facilitate safety-related applications; however, in all instances customers and users are responsible for (a) selecting the appropriate Diodes products for their applications, (b) evaluating the suitability of the Diodes products for their intended applications, (c) ensuring their applications, which incorporate Diodes products, comply the applicable legal and regulatory requirements as well as safety and functional-safety related standards, and (d) ensuring they design with appropriate safeguards (including testing, validation, quality control techniques, redundancy, malfunction prevention, and appropriate treatment for aging degradation) to minimize the risks associated with their applications.
3. Diodes assumes no liability for any application-related information, support, assistance or feedback that may be provided by Diodes from time to time. Any customer or user of this document or products described herein will assume all risks and liabilities associated with such use, and will hold Diodes and all companies whose products are represented herein or on Diodes’ websites, harmless against all damages and liabilities.
4. Products described herein may be covered by one or more United States, international or foreign patents and pending patent applications. Product names and markings noted herein may also be covered by one or more United States, international or foreign trademarks and trademark applications. Diodes does not convey any license under any of its intellectual property rights or the rights of any third parties (including third parties whose products and services may be described in this document or on Diodes’ website) under this document.
5. Diodes products are provided subject to Diodes’ Standard Terms and Conditions of Sale (<https://www.diodes.com/about/company/terms-and-conditions/terms-and-conditions-of-sales/>) or other applicable terms. This document does not alter or expand the applicable warranties provided by Diodes. Diodes does not warrant or accept any liability whatsoever in respect of any products purchased through unauthorized sales channel.
6. Diodes products and technology may not be used for or incorporated into any products or systems whose manufacture, use or sale is prohibited under any applicable laws and regulations. Should customers or users use Diodes products in contravention of any applicable laws or regulations, or for any unintended or unauthorized application, customers and users will (a) be solely responsible for any damages, losses or penalties arising in connection therewith or as a result thereof, and (b) indemnify and hold Diodes and its representatives and agents harmless against any and all claims, damages, expenses, and attorney fees arising out of, directly or indirectly, any claim relating to any noncompliance with the applicable laws and regulations, as well as any unintended or unauthorized application.
7. While efforts have been made to ensure the information contained in this document is accurate, complete and current, it may contain technical inaccuracies, omissions and typographical errors. Diodes does not warrant that information contained in this document is error-free and Diodes is under no obligation to update or otherwise correct this information. Notwithstanding the foregoing, Diodes reserves the right to make modifications, enhancements, improvements, corrections or other changes without further notice to this document and any product described herein. This document is written in English but may be translated into multiple languages for reference. Only the English version of this document is the final and determinative format released by Diodes.
8. Any unauthorized copying, modification, distribution, transmission, display or other use of this document (or any portion hereof) is prohibited. Diodes assumes no responsibility for any losses incurred by the customers or users or any third parties arising from any such unauthorized use.

Copyright © 2021 Diodes Incorporated

www.diodes.com

单击下面可查看定价，库存，交付和生命周期等信息

[>>Diodes Incorporated\(达达科技\(美台\)\)](#)