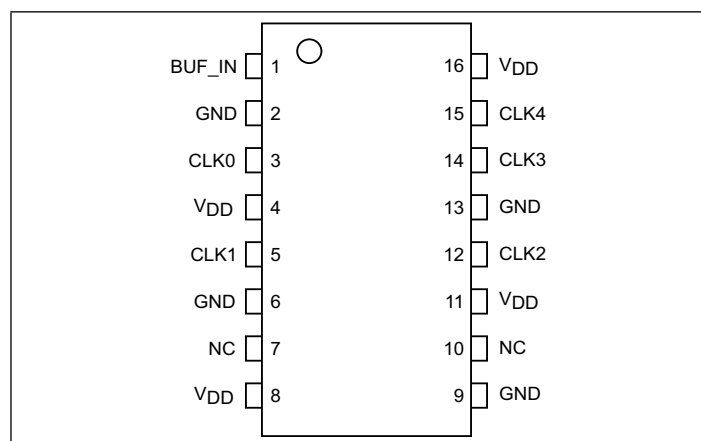
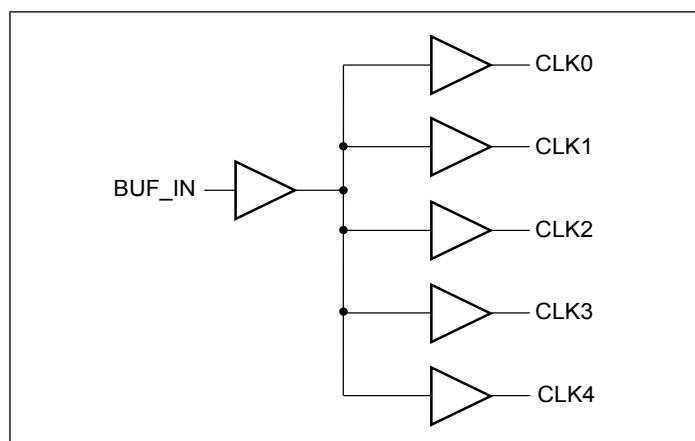
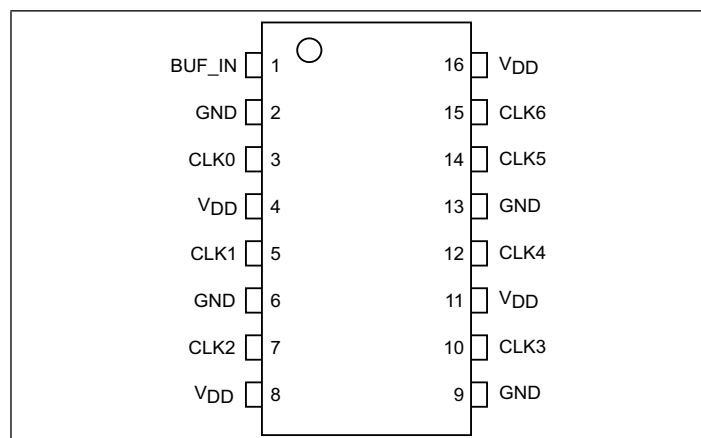
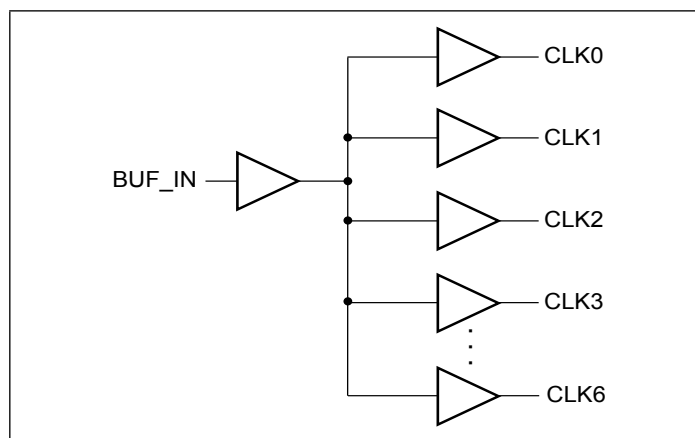

**1:5/1:7 2.5V Clock Buffer for Networking Applications**
**Features**

- High Frequency >150 MHz
- High-speed, low-noise, non-inverting clock buffer
  - PI49FCT20802 is a 1:5 buffer
  - PI49FCT20803 is a 1:7 buffer
- Low skew < 150ps
- Low duty cycle distortion < 300ps
- Low propagation delay < 3.5ns
- Multiple V<sub>DD</sub>, GND pins for noise reduction
- 2.5V supply voltage and 3V tolerant input
- Packaging (Pb-free & Green):
  - 16-pin TSSOP (L)
  - 16-pin QSOP (Q) - PI49FCT20802 only

**Description**

The PI49FCT2080x is 2.5V, high-speed, low noise, non-inverting clock buffer. It is designed to target networking applications that require low-skew, low-jitter, and high-frequency clock distribution. It provides output-to-output skew as low as 150ps, and is an ideal clock distribution device for synchronous systems. PI49FCT2080x is a clock buffer from a single input that produces five outputs on PI49FCT20802 and seven outputs on PI49FCT20803. PI49FCT2080x is characterized for operation from -40°C to 85°C.

**Pin Configuration (PI49FCT20802)**

**Block Diagram (PI49FCT20802)**

**Pin Configuration (PI49FCT20803)**

**Block Diagram (PI49FCT20803)**



**Absolute Maximum Ratings** (Over operating free-air temperature range)

Parameter	Min.	Max.	Units
Storage temperature	-65	150	°C
Supply Voltage $V_{DD}$	-0.5	3.6	V
Input/Output Voltages <sup>(1)</sup>	-0.5	$V_{DD} + 0.5$	V
DC Output Current	-60	60	mA
Power Dissipation	-	500	mW

Stress beyond those listed under “Absolute Maximum Ratings” may cause permanent damage to the device.

**Operating Range**

Parameter	Min.	Max.	Units
$V_{DD}$ Voltage	2.5±0.2		V
Industrial Temperature	-40	85	°C
Commercial Temperature	0	70	°C
Capacitive Loading	10	25	pF

**DC Electrical Characteristics** (Over the Operating Range)

Parameters	Description	Test Conditions <sup>(1)</sup>	Min	Typ <sup>(2)</sup>	Max	Units
$V_{IH}$	Input HIGH Voltage		1.7			V
$V_{IL}$	Input LOW Voltage				0.7	
$I_I$	Input Current	$V_{DD} = 0$ or $V_{DD}$			±1	mA
$V_{IK}$	Clamp Diode Voltage	$V_{DD} = \text{Min.}, I_{IN} = -18 \text{ mA}$		-0.7	-1	V
$V_{OH}$	Output HIGH Voltage	$V_{DD} = \text{Min.}$	$I_{OH} = -1 \text{ mA}$	2		
			$I_{OH} = -8 \text{ mA}$	1.8 <sup>(3)</sup>		
$V_{OL}$	Output LOW Voltage	$V_{DD} = \text{Min.}$	$I_{OH} = 1 \text{ mA}$		0.4	
			$I_{OH} = 8 \text{ mA}$		0.6	

**Notes:**

1. This value is limited to 3.6V maximum.
2. For Max. or Min. conditions, use appropriate value specified under Electrical Characteristics for the applicable device type.
3. Typical values are at  $V_{DD} = 2.5\text{V}$ , +25°C ambient and maximum loading.



### Power Supply Characteristics

Parameters	Description	Test Conditions <sup>(4)</sup>	Min	Typ <sup>(5)</sup>	Max	Units
$I_{DDQ}$	Quiescent Power Supply Current	$V_{IN} = 0$ or $V_{DD}$		0.1	20	$\mu A$
$\Delta I_{DD}$	Supply Current per Input	$V_{IN} = V_{DD} - 0.6V^{(6)}$		47	300	
$I_{DD}$	Dynamic Supply Current (See Graph 1)	$V_{DD} = 2.7V$ , 15pF & 33-ohm load, $f = 150$ MHz		136		mA

**Notes:**

- 4. For Max. or Min. conditions, use appropriate value specified under Electrical Characteristics for the applicable device.
- 5. Typical values are at  $V_{DD} = 2.5V$ , +25°C ambient and maximum loading.
- 6. Per TTL driven input ( $V_{IN} = V_{DD} - 0.6V$ ); all other inputs at  $V_{DD}$  or GND.

### Graph 1. Dynamic Current vs. Clock Frequency

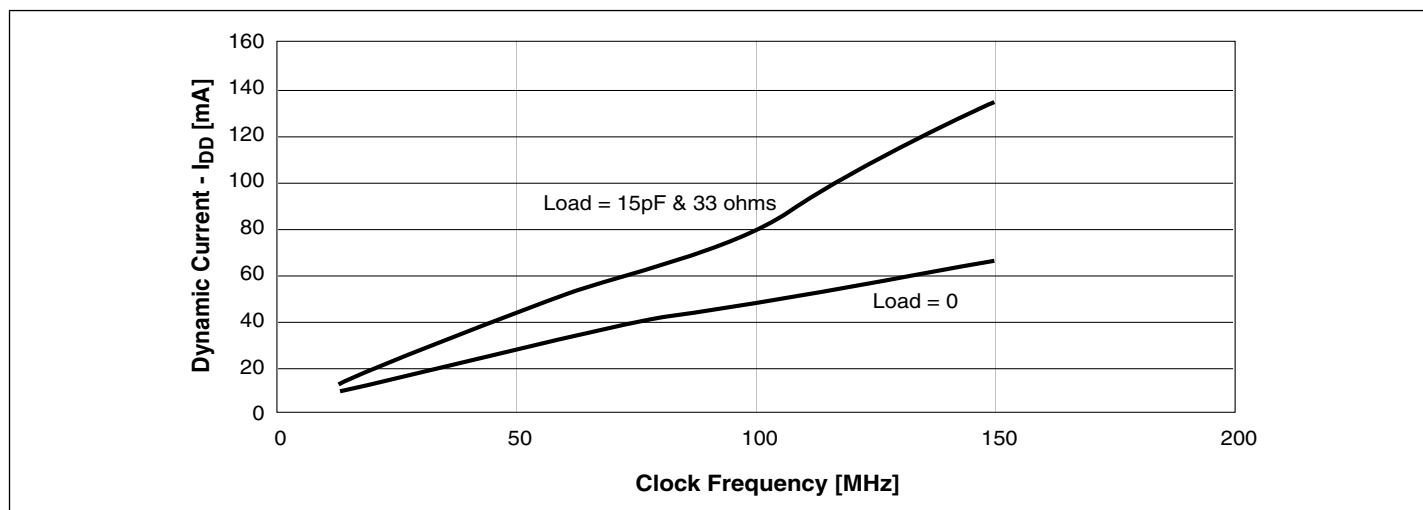

### Capacitance ( $T_A = 25^\circ C$ , $f = 1$ MHz)

Parameters <sup>(3)</sup>	Description	Test Conditions	Typ <sup>(7)</sup>	Max	Units
$C_{IN}$	Input Capacitance	$V_{IN} = 0V$	3	4	pF
$C_{OUT}$	Output Capacitance	$V_{OUT} = 0V$		6	

**Notes:**

- 7. This parameter is determined by device characterization but is not production tested.



**Switching Characteristics** (VDD = 2.5V ± 0.2V, TA = 85°C)

Parameters	Description	Test Conditions <sup>(8)</sup>	Min	Typ	Max	Units
f <sub>CLK</sub>	Output Frequency				150	MHz
t <sub>R/F</sub>	Rise/Fall time V <sub>O</sub> = 0.7V ~ 1.7 V	C <sub>L</sub> = 22pF, 100 MHz		1.0	1.25	ns
		C <sub>L</sub> = 12pF, 150 MHz		1.0	1.2	
t <sub>PD</sub>	Propagation Delay	C <sub>L</sub> = 22pF, 100 MHz		3.5	3.5	ns
		C <sub>L</sub> = 12pF, 150 MHz		2.4	2.7	
t <sub>SK(o)</sub>	Output Skew	C <sub>L</sub> = 22pF, 100 MHz		100	150	ps
		C <sub>L</sub> = 12pF, 150 MHz		100	150	
t <sub>SK(p)</sub>	Pulse Skew	C <sub>L</sub> = 22pF, 100 MHz		250	300	ps
		C <sub>L</sub> = 12pF, 150 MHz		250	300	
t <sub>SK(d)</sub>	Device-to-device skew <sup>(9)</sup>	C <sub>L</sub> = 12pF, 150 MHz		400	600	ps

**Notes:**

- 8. See test circuit and waveforms.
- 9. Identical conditions: loading, transitions, supply voltage, temperature, package type and speed grade.

**Pin Description**

Pin Name		Description
PI49FCT20802	PI49FCT20803	
BUF_IN	BUF_IN	Input
CLK [0:4]	CLK [0:6]	Outputs
GND	GND	Ground
V <sub>DD</sub>	V <sub>DD</sub>	Power

**Test Circuits for All Outputs**

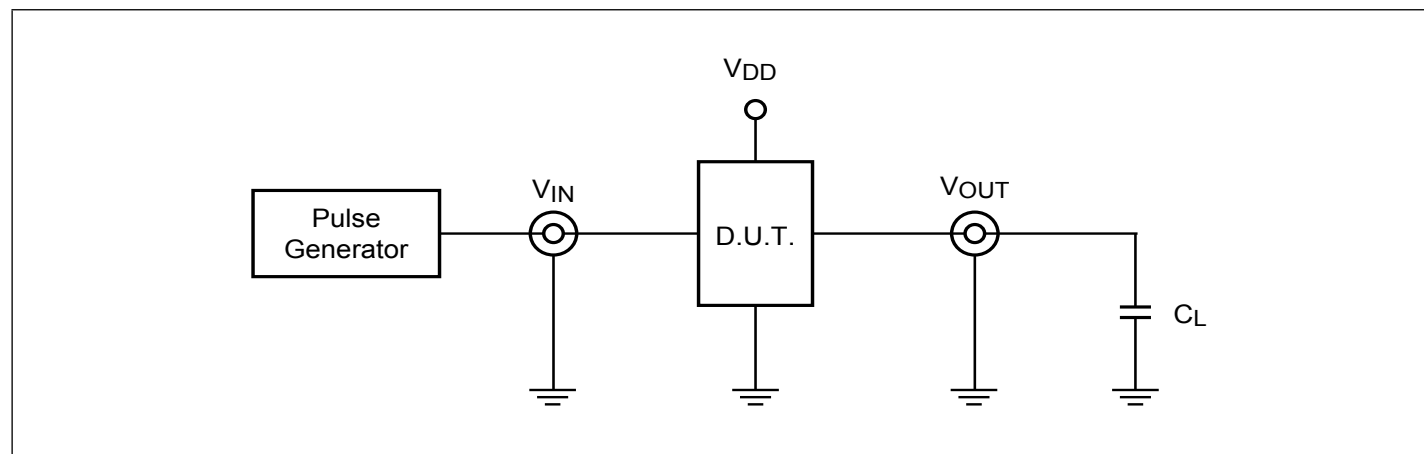



Switching Waveforms

Propagation Delay

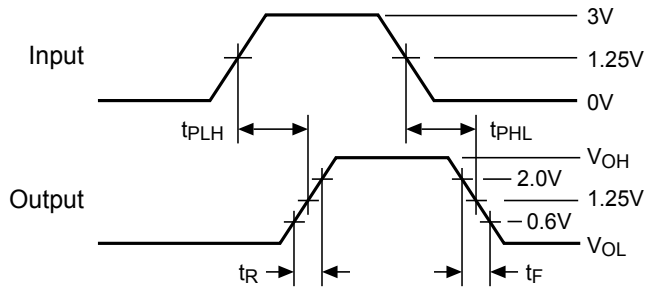

Pulse Skew -  $t_{SK(P)}$

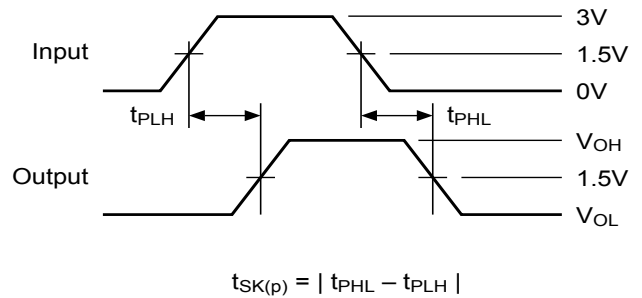

Output Skew -  $t_{SK(O)}$

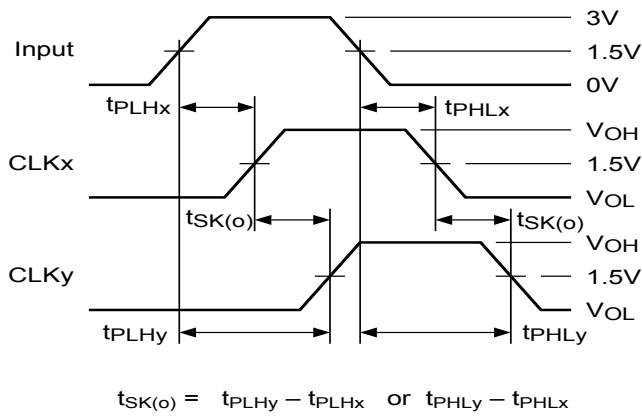

Package Skew -  $t_{SK(T)}$

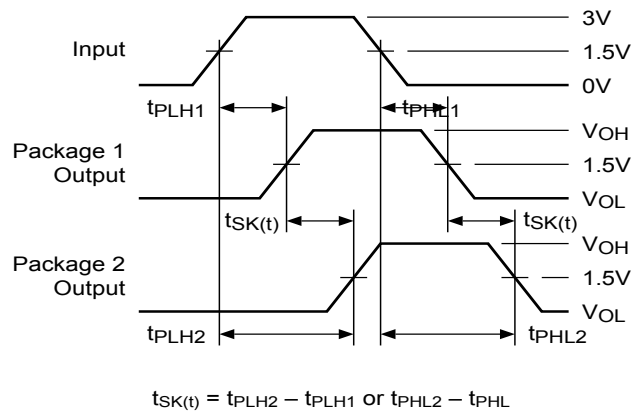

**PI49FCT20802/PI49FCT20803**

1:5/1:7 2.5V Clock Buffer for  
Networking Applications



**Packaging Mechanical: 16-Pin TSSOP (L)**

DOCUMENT CONTROL NO.  
PD - 1310

REVISION: E  
DATE: 03/09/05

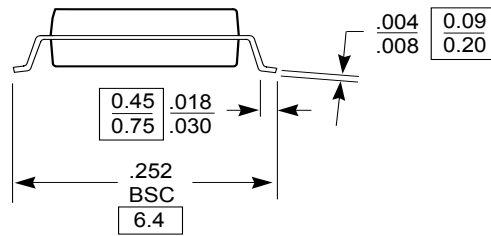
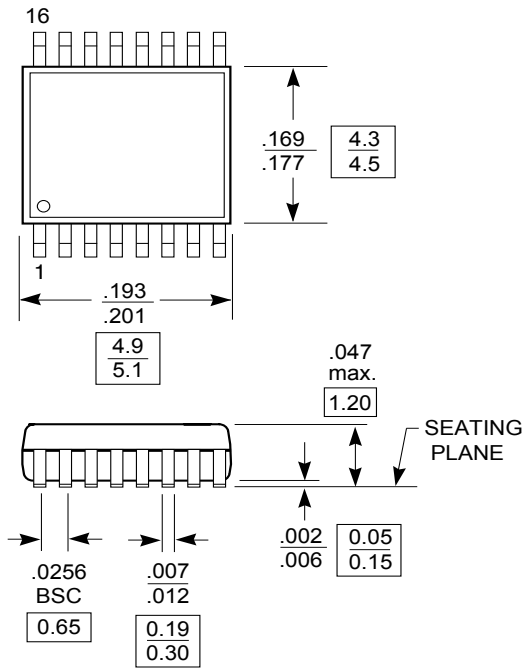

- Note:**
1. Package Outline Exclusive of Mold Flash and Metal Burr
  2. Controlling dimensions in millimeters
  3. Ref. JEDEC MO-153F/AB



Pericom Semiconductor Corporation  
3545 N. 1st Street, San Jose, CA 95134  
1-800-435-2335 • www.pericom.com

DESCRIPTION: 16-Pin, 173-Mil Wide, TSSOP

PACKAGE CODE: L

# PI49FCT20802/PI49FCT20803

1:5/1:7 2.5V Clock Buffer for Networking Applications



## Packaging Mechanical: 16-Pin QSOP (Q)

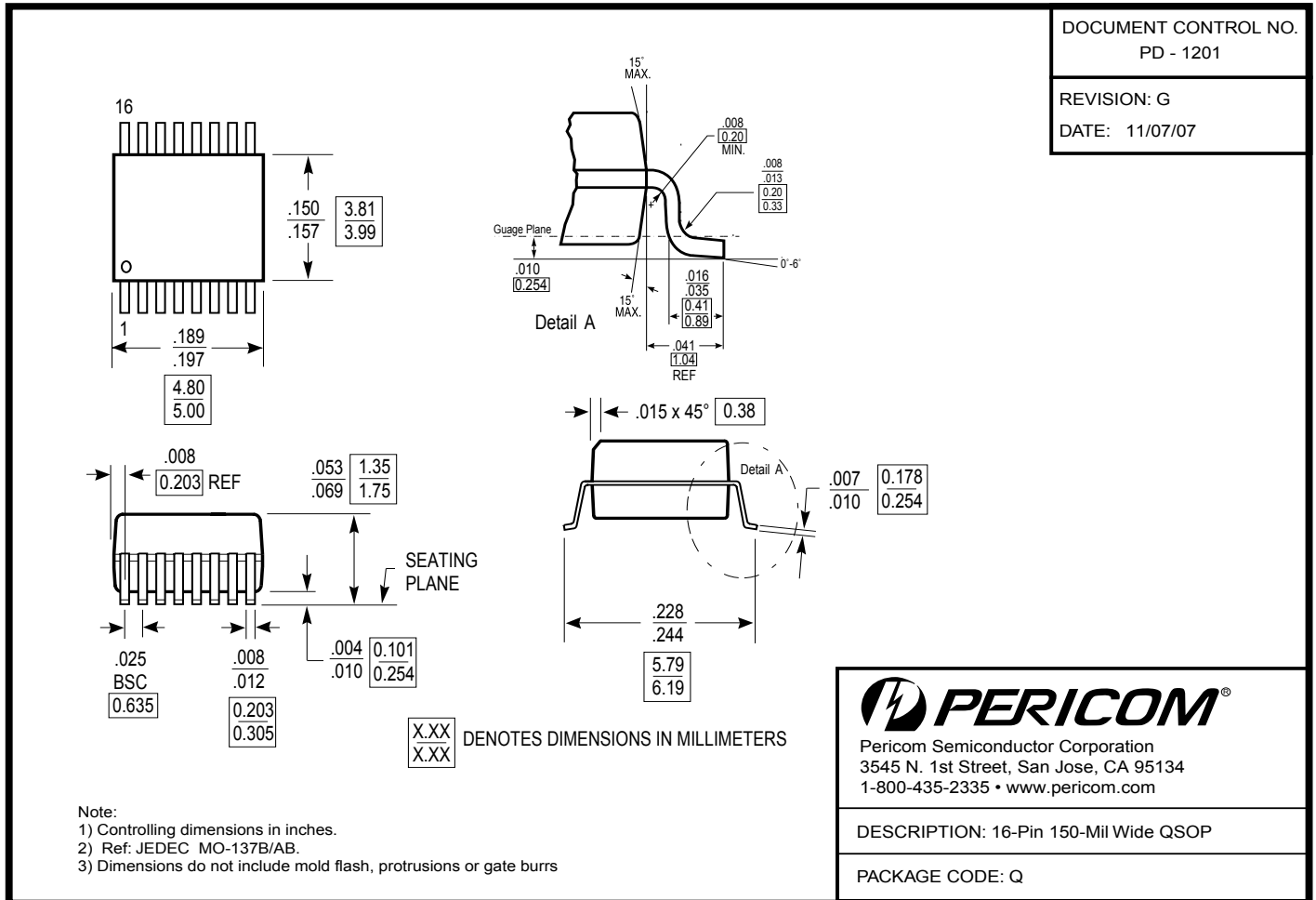

## Ordering Information

Ordering Code	Package Code	Package Type
PI49FCT20802QE	Q	Pb-free & Green, 16-pin 150-mil wide QSOP
PI49FCT20802LE	L	Pb-free & Green, 16-pin 173-mil wide TSSOP
PI49FCT20803LE	L	Pb-free & Green, 16-pin 173-mil wide TSSOP

1. Thermal characteristics can be found on the company web site at [www.pericom.com/packaging/](http://www.pericom.com/packaging/)

2. E = Pb-free & Green

3. Adding an X suffix = Tape/Reel

单击下面可查看定价，库存，交付和生命周期等信息

[>>Diodes Incorporated\(达达科技\(美台\)\)](#)