

DIO6809

Ultra Low Power Microprocessor Reset Circuit

Features

- 140ms min Reset Pulse Width
- 10µA TypSupply Current @V_{CC}=3V
- Guaranteed Reset Valid to V_{CC} = +1.0V
- Power Supply Transient Immunity
- Operating Temperature Range
-40°C to +85°C
- Available in SOT-23 and SOT-23-3L

Block Diagram

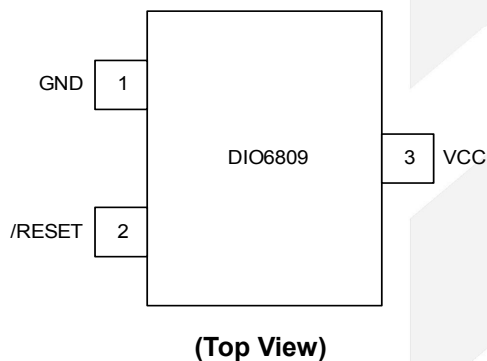

Descriptions

DIO6809 series are micro-processor(µP) supervisory circuits used to monitor the power supplies in µP and digital systems. They provide excellent circuit reliability and low cost by eliminating external components.

These circuits perform a single function: they assert a reset signal whenever the V_{CC} supply voltage declines below a preset threshold, keeping it asserted for at least 140ms after V_{CC} has risen above the reset threshold.

The DIO6809 has CMOS outputs. The DIO6809 has an active-low /RESET output, Thereset comparator is designed to ignore fast transients on V_{CC}, and the outputs are guaranteed to be in the correct logic state for V_{CC} down to 1.0V over the temperature range.

The device is available in 3 pin SOT-23 and SOT-23-3L package.

Applications

- Computers
- Controllers
- Intelligent Instruments
- Portable/Battery-Powered Equipment

Ordering Information

Order Part Number		T _A	Package	
DIO6809XST3	RoHS	-40 to +85°C	SOT-23	Tape & Reel, 3000
DIO6809XSU3	RoHS	-40 to +85°C	SOT-23-3L	Tape & Reel, 3000



DIO6809

Ordering Information Complimentary Note

Ordering Code = Part No. + Package Code

ST3: stands for SOT-23
 SU3: stands for SOT-23-3L

X: Refer to Device Function Reference Table on Page 2

Device Function Reference Table

Part No.	Reset threshold	Reset active Low or High	Output Type	Marking
DIO6809L	4.63V	Low	CMOS	AAAA
DIO6809M	4.38V	Low	CMOS	ABAA
DIO6809J	4.00V	Low	CMOS	CWAA
DIO6809T	3.08V	Low	CMOS	ACAA
DIO6809S	2.93V	Low	CMOS	ADAA
DIO6809R	2.63V	Low	CMOS	AFAA
DIO6809Z	2.32V	Low	CMOS	AEAA

Block Diagram

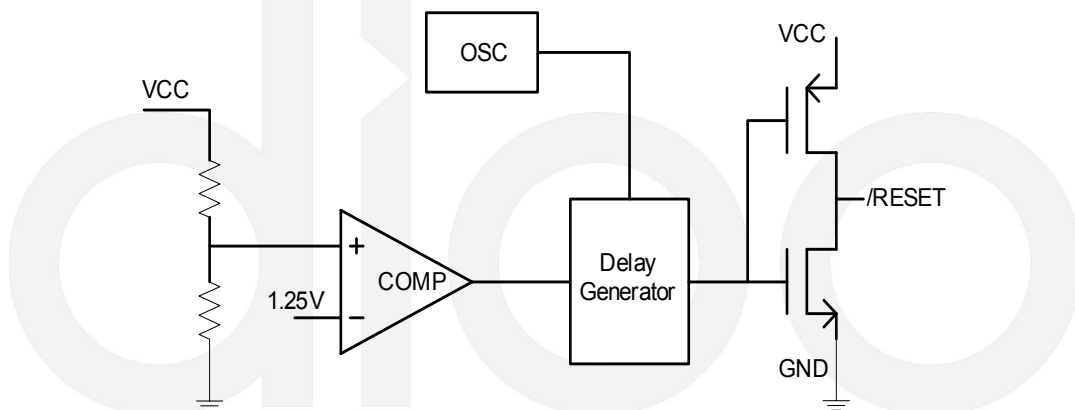



DIO6809

Pin Descriptions

Pin No.	Symbol	Description
1	GND	Ground terminal
2	/RESET	CMOS output. This output remains low if V_{CC} drops below $V_{RES}-V_{HYST}$, and for at least 140ms after V_{CC} rises above V_{RES} .
3	V_{CC}	Analog input. This pin is both the power supply to internal circuit and the voltage to be monitored

Absolute Maximum Ratings

Stresses beyond those listed under "Absolute Maximum Rating" may cause permanent damage to the device. These are stress ratings only and functional operation of the device at these or any other condition beyond those indicated in the operational sections of the specifications is not implied. Exposure to absolute maximum rating conditions for extended periods may affect device reliability.

Parameter		Rating	Units
Terminal Voltage (With respect to GND)	V_{CC}	-0.3 to 6.0	V
	/RESET	-0.3 to 6.0	
Input Current	V_{CC}	20	mA
	/RESET	20	
Thermal Resistance		300	°C/W
Operating Temperature		-40 to 85	°C
Lead Temperature Range (soldering 10s)		300	°C
Storage Temperature		-65 to 150	°C
ESD HBM, JEDEC: JESD22-A114		4500	V



DIO6809

Ultra Low Power Microprocessor Reset Circuit

DC Electrical Characteristics

Typical value: $V_{CC}=3V$, $T_A=25^{\circ}C$, unless otherwise noted.

Parameters	Symbol	Test Conditions	Min	Typ	Max	Unit
Maximum input voltage	V_{CCMAX}				5.5	V
Minimum input voltage	V_{CCMIN}		1.0			V
Supply current	I_{VCC}	$V_{CC}=2.0V$		8		uA
		$V_{CC}=3.0V$		10		
		$V_{CC}=5.0V$		14		
Reset Threshold	V_{RES}	DIO6809L	4.51	4.63	4.75	V
		DIO6809M	4.25	4.38	4.5	
		DIO6809J	3.9	4.00	4.1	
		DIO6809T	3.0	3.08	3.15	
		DIO6809S	2.75	2.93	3.05	
		DIO6809R	2.56	2.63	2.7	
		DIO6809Z	2.26	2.32	2.38	
Temperature coefficient of reset threshold	T_C				± 100	ppm
Reset Threshold hysteresis	V_{HYST}			$0.05V_{RES}$		V
V_{CC} to /RESET Delay		V_{CC} transitions from $V_{RES}+0.1V$ to $V_{RES}-0.1V$		23		us
/RESET Output Voltage Low	V_{OL}	$V_{CC}=2V, V_{RES}>2V, I_{SINK}=1.5mA$			0.3	V
		$V_{CC}=3V, V_{RES}>3V, I_{SINK}=3.2mA$			0.3	
		$V_{CC}=4V, V_{RES}>4V, I_{SINK}=5mA$			0.3	
/RESET Output Voltage High	V_{OH}	$V_{CC}=3V, V_{RES}<3V, I_{SOURCE}=1.2mA$	$V_{CC}-0.4$			V
		$V_{CC}=4V, V_{RES}<4V, I_{SOURCE}=2mA$	$V_{CC}-0.4$			
		$V_{CC}=5V, V_{RES}<5V, I_{SOURCE}=2.5mA$	$V_{CC}-0.4$			
Reset Pulse Width	T_{RES}		140	240	500	ms

Specifications subject to change without notice.



DIO6809

Detailed Description

A microprocessor's (μP 's) reset input starts the μP in a known state. The DIO6809 series assert reset to prevent code-execution errors during power-up, power-down, or brownout conditions. The device consists of a comparator, a low current high precision voltage reference, voltage divider, output delay circuit and output driver. They assert a reset signal whenever the V_{CC} supply voltage declines below a preset threshold, keeping it asserted for at least 140ms after V_{CC} has risen above the reset threshold.

The DIO6809 have a CMOS output stage. The DIO6809 have an active-low /RESET output, The reset comparator is designed to ignore fast transients on V_{CC} , and the outputs are guaranteed to be in the correct logic state for V_{CC} down to 1.0V over the temperature range.

The operation of the device can be best understood by referring to figure 2.

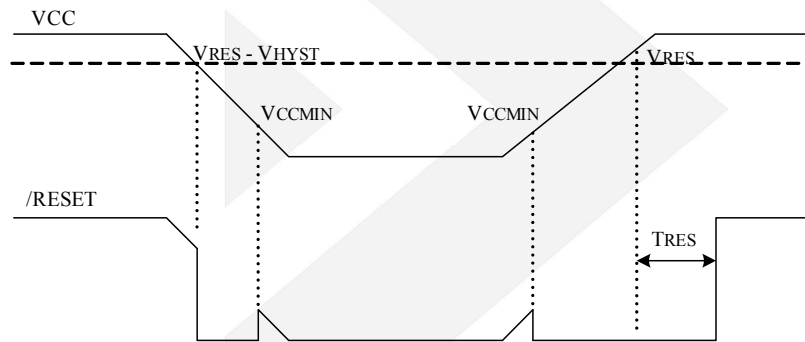

Applications Information

Negative-Going V_{CC} Transients

In addition to issuing a reset to the μP during power-up, power-down, and brownout conditions, the DIO6809 series are relatively immune to short-duration negative-going V_{CC} transients (glitches). As the magnitude of the transient increases (goes farther below the reset threshold), the maximum allowable pulse width decreases. Typically, a V_{CC} transient that goes 100mV below the reset threshold and lasts 10 μs or less will not cause a reset pulse. A 0.1 μF bypass capacitor mounted as close as possible to the V_{CC} pin provides additional transient immunity.

Ensuring a Valid Reset Output Down to $V_{\text{CC}} = 0$

When V_{CC} falls below 1.0V, the DIO6809 /RESET output no longer sinks current—it becomes an open circuit. Therefore, high-impedance CMOS logic inputs connected to /RESET can drift to undetermined voltages. This presents no problem in most applications, since most μP and other circuitry is inoperative with V_{CC} below 1.0V.

DIO6809

However, in applications where /RESET must be valid down to 0V, a pull-down resistor is needed from /RESET pin to GND as shown in Figure 3, then /RESET output will be held at low state. The resistor's value is not critical, it should be about 100K Ω , large enough not to load /RESET, small enough to pull /RESET to ground.

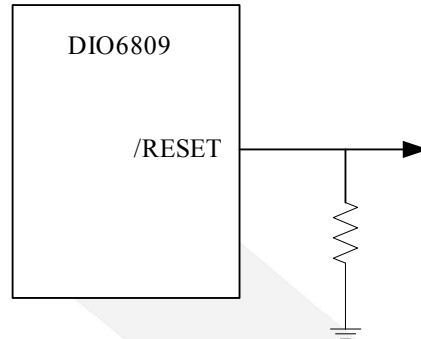

Figure 3 RESET Valid to Ground Circuit

dioo

Typical Performance Characteristics

All typical value: $V_{CC}=5V$, $T_A=25^\circ C$, unless otherwise specified.

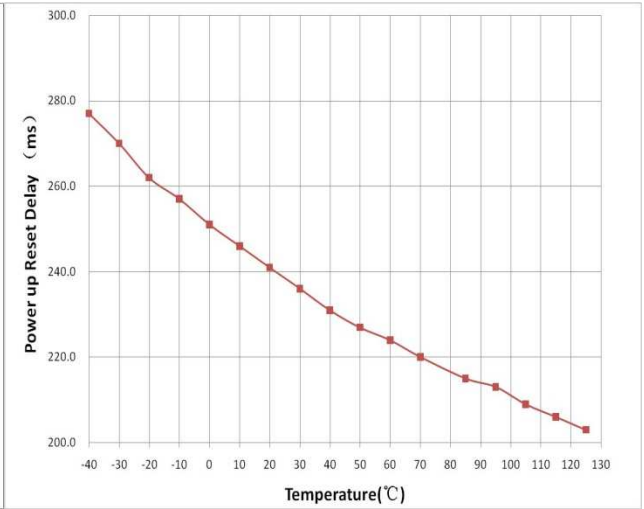
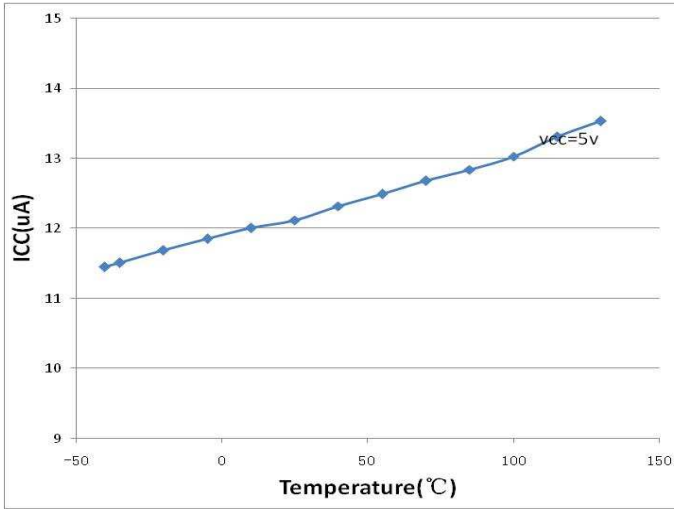

Figure 4 Figure 5

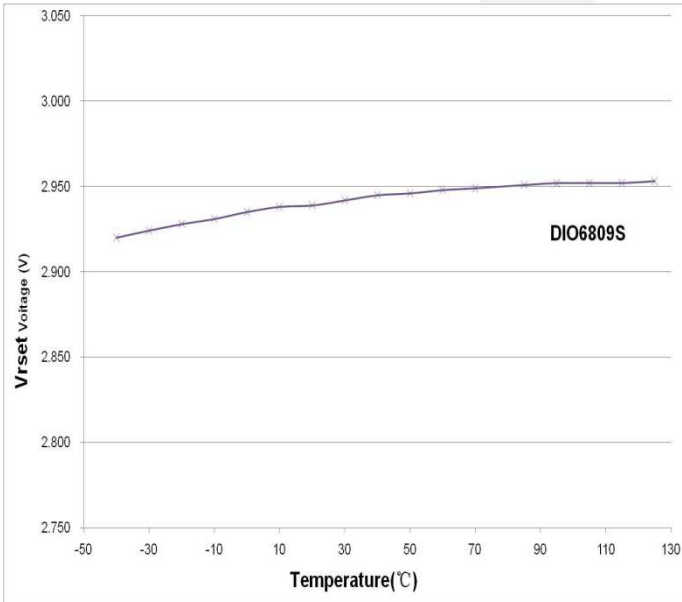

Figure 6

CONTACT US

Dioo is a professional design and sales corporation for high-quality and performance analog semiconductors. The company focuses on industry markets, such as, cell phone, handheld products, laptop, and medical equipments and so on. Dioo's product families include analog signal processing and amplifying, LED drivers and charger IC. Go to <http://www.dioo.com> for a complete list of Dioo product families.

For additional product information, or full datasheet, please contact with our Sales Department or Representatives.



单击下面可查看定价，库存，交付和生命周期等信息

[>>Dioo\(帝奥微\)](#)