

## Adjustable Reference Source

TO-92 (TOP VIEW)

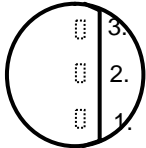

- 1. REF
- 2. ANODE
- 3. CATHODE

SOT-23

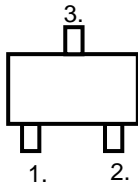

- 1. REF
- 2. CATHODE
- 3. ANODE

SOT-89

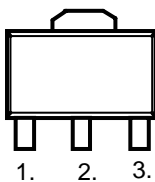

- 1. REF
- 2. ANODE
- 3. CATHODE

### ADJUSTABLE ACCURATE REFERENCE SOURCE

The TL431 is three-terminal adjustable shunt regulator with specified thermal stability.

The output voltage may be set to any value between  $V_{REF}$  (Approx. 2.5V) and 36V with two external resistors. This device has a typical output impedance of  $0.2\Omega$ .

Active output circuitry provides a very sharp turn-on characteristic, making this device excellent replacement for zener diodes in many application.

### Features

- Equivalent Full Range Temperature Coefficient 50PPM/°C
- Temperature Compensated For Operation Over Full Rate Operating Temperature Range
- Adjustable Output Voltage
- Fast Turn-on Response
- Sink Current Capability 1mA to 100mA
- Low ( $0.2\Omega$  Typ.) Dynamic Output Impedance
- Low Output Noise

### FUNCTION BLOCK DIAGRAM

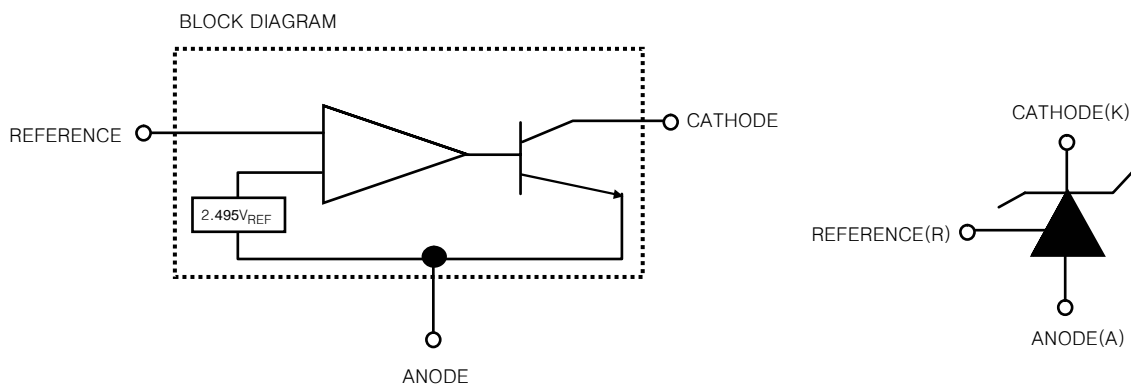

ABSOLUTE MAXIMUM RATINGS							
(Full Operating Ambient Temperature Range Applies Unless Otherwise Noted)							
CHARACTERISTIC	SYMBOL	RATING		UNIT			
Cathode Voltage	$V_{KA}$	37		V			
Continuous Cathode Current Range	$I_{KA}$	-100~+150		mA			
Reference Input Current Range	$I_{REF}$	0.05~10		mA			
Junction Temperature	$T_J$	150		°C			
Operating Temperature	$T_{OPR}$	-20 ~ 85		°C			
Storage Temperature	$T_{STG}$	-65 ~ 150		°C			
Total Power Dissipation	$P_D$	700		mW			
ELECTRICAL CHARACTERISTIC ( $T_A=25^\circ\text{C}$ , unless otherwise specified)							
CHARACTERISTIC	SYMBOL	CIR-CUIT	TEST CONDITION	MIN.	TYP.	MAX.	UNIT
Deviation of Reference Input Voltage Over Full Temperature Range	$\Delta V_{REF}/\Delta T$	1	$V_{KA}=V_{REF}, I_K=10\text{mA}$ $T_A=\text{Full Range}$		3	17	mV
Ratio of Change in Reference Input Voltage to the Change in Cathod Voltage	$\Delta V_{REF}/\Delta V_{KA}$	2	$I_K=10\text{mA}$	$\Delta V_{KA}=10\text{V}-V_{REF}$	-1.4	-2.7	mV/V
				$\Delta V_{KA}=36\text{V}-10\text{V}$	-1	-2	
Reference Input Current	$I_{REF}$	2	$I_{KA}=10\text{mA}, R1=10\text{k}\Omega, R2=\infty$		1.8	4	$\mu\text{A}$
Deviation of Reference Input Current Over Full Temperature Range	$\Delta I_{REF}/\Delta T$	2	$I_K=10\text{mA}, R1=10\text{k}\Omega, R2=\infty$ $T_A=\text{Full Range}$		0.4	1.2	$\mu\text{A}$
Minimum Cathode Current for Regulation	$I_{K\text{MIN}}$	1	$\Delta V_{KA}=V_{REF}$		0.5	1	mA
Off-State Cathode Current	$I_{K\text{OFF}}$	3	$V_{KA}=36\text{V}, V_{REF}=0$		0.2	1	$\mu\text{A}$
Dynamic Impedance	$Z_{KA}$	1	$V_{KA}=V_{REF}, I_K=1\text{mA}\sim 100\text{mA},$ $f\leq 1\text{kHz}$		0.2	0.5	$\Omega$
CLASSIFICATION OF $V_{REF}$							
Rank	TYP.	0.5%		0.5%		1%	
Range	2.49	2.487-2.502		2.487-2.513		2.475-2.525	

Fig. 1 Test Circuit for  $V_{KA} = V_{REF}$

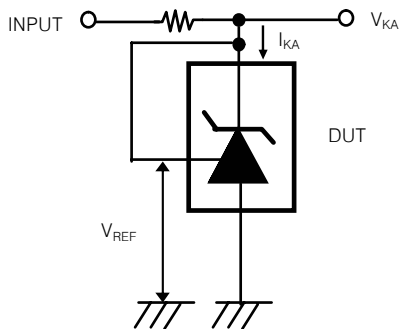

Fig. 2 Test Circuit for  $V_{KA} \geq V_{REF}$

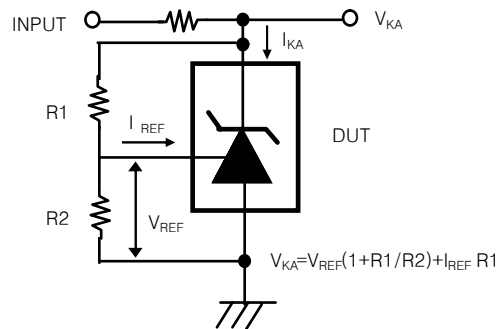
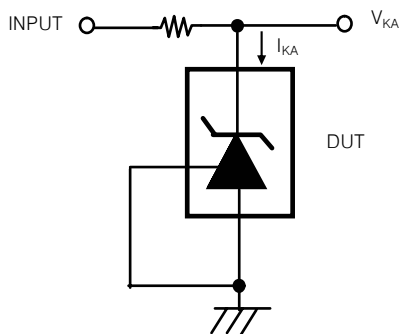
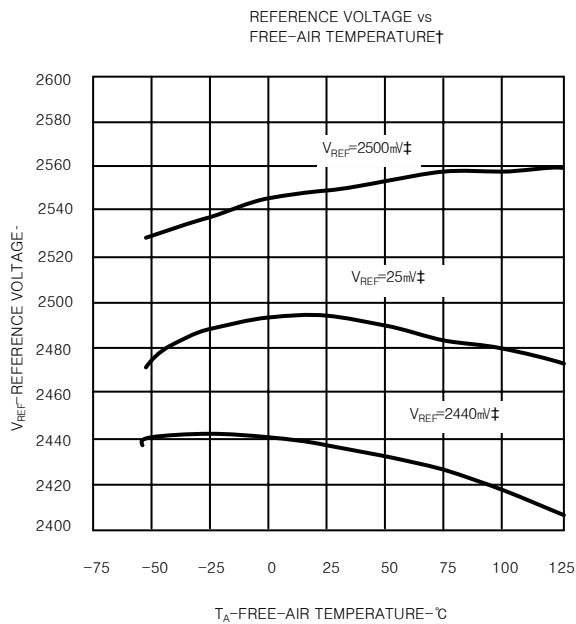

Fig. 3 Test Circuit for  $I_{KA}$  (off)



TYPICAL PERFORMANCE CHARACTERISTICS



† Data is applicable only within the recommended operating free-air temperature ranges of the various devices.

‡ Data is for devices having the indicated value of  $V_{REF}$  at  $I_{KA}=10mV$ ,  $T_A=25°C$

Figure 4.

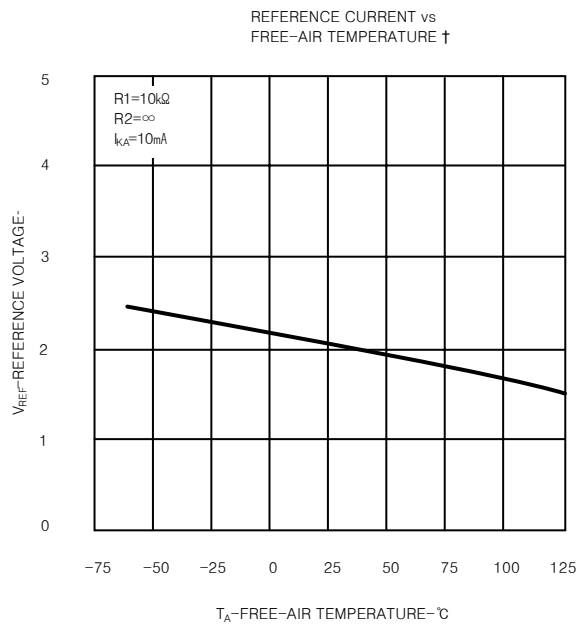

† Data is applicable only within the recommended operating free-air temperature ranges of the various devices.

Figure 5.

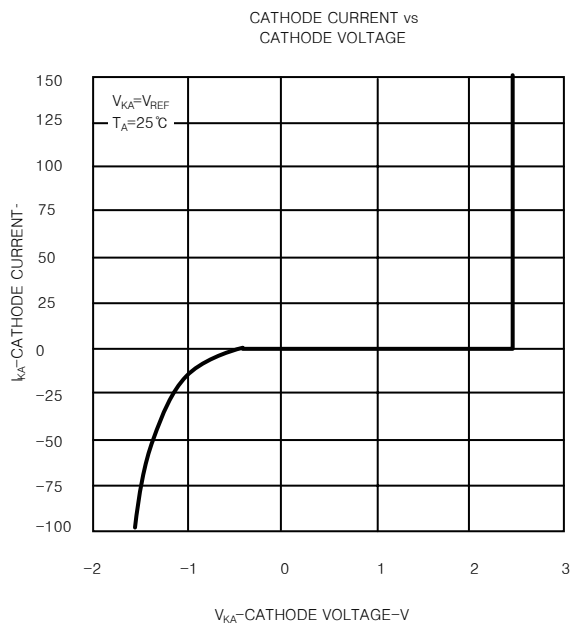

Figure 6.

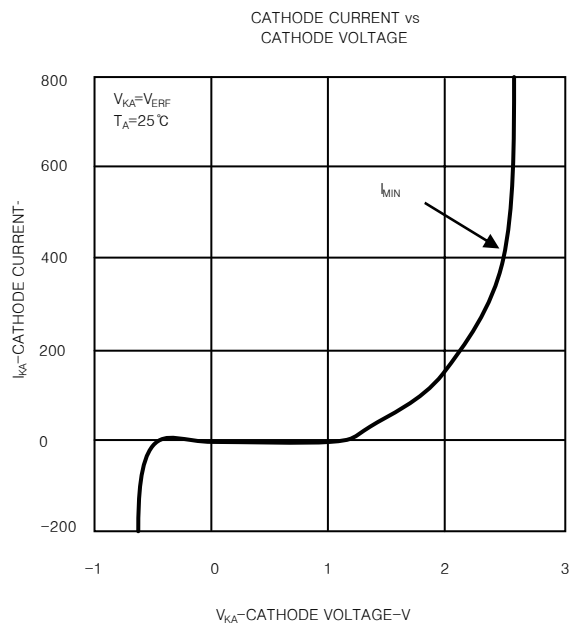
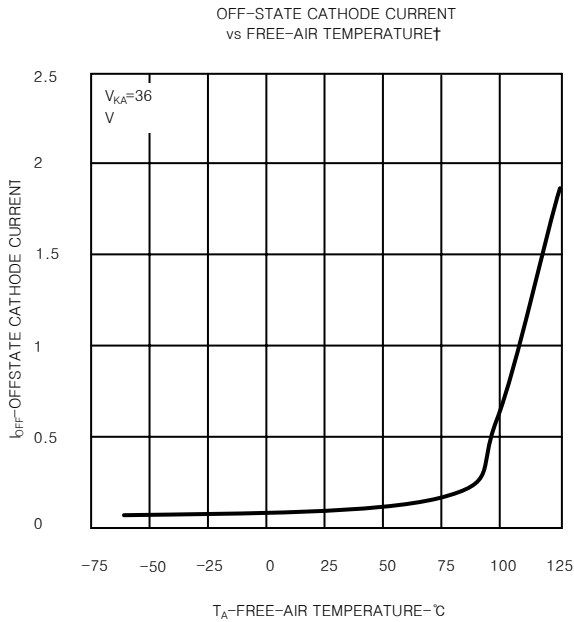

Figure 7.

TYPICAL PERFORMANCE CHARACTERISTICS



† Data is applicable only within the recommended operating free-air temperature ranges of the various devices.

Figure 8.

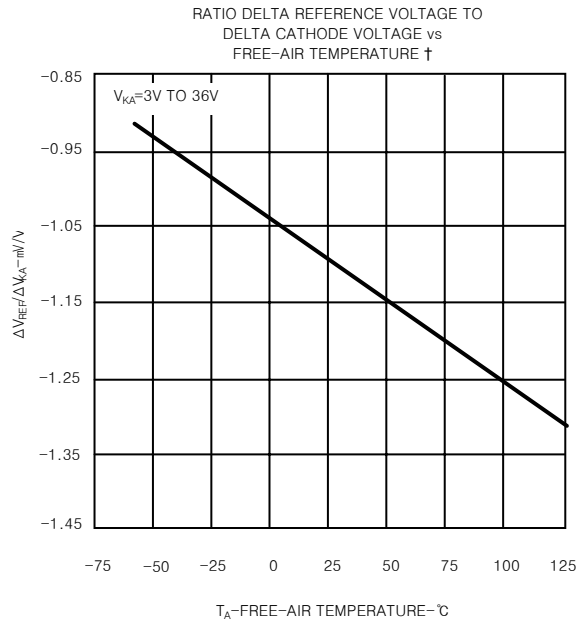

† Data is applicable only within the recommended operating free-air temperature ranges of the various devices.

Figure 9.

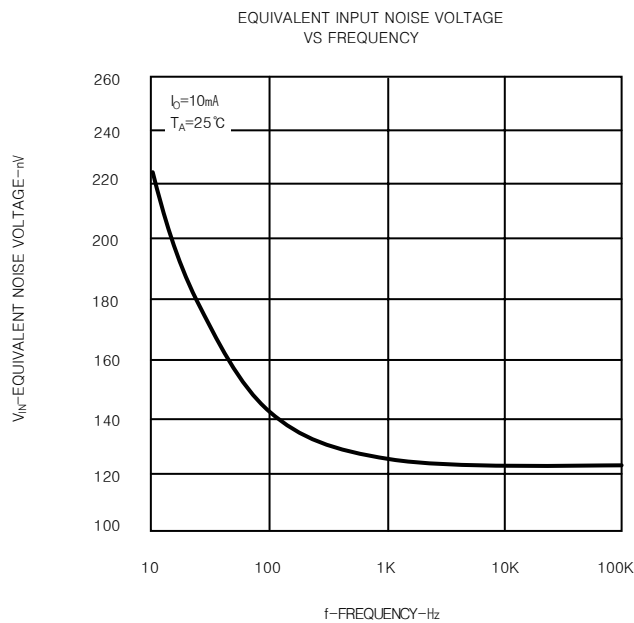

Figure 10.

TYPICAL PERFORMANCE CHARACTERISTICS

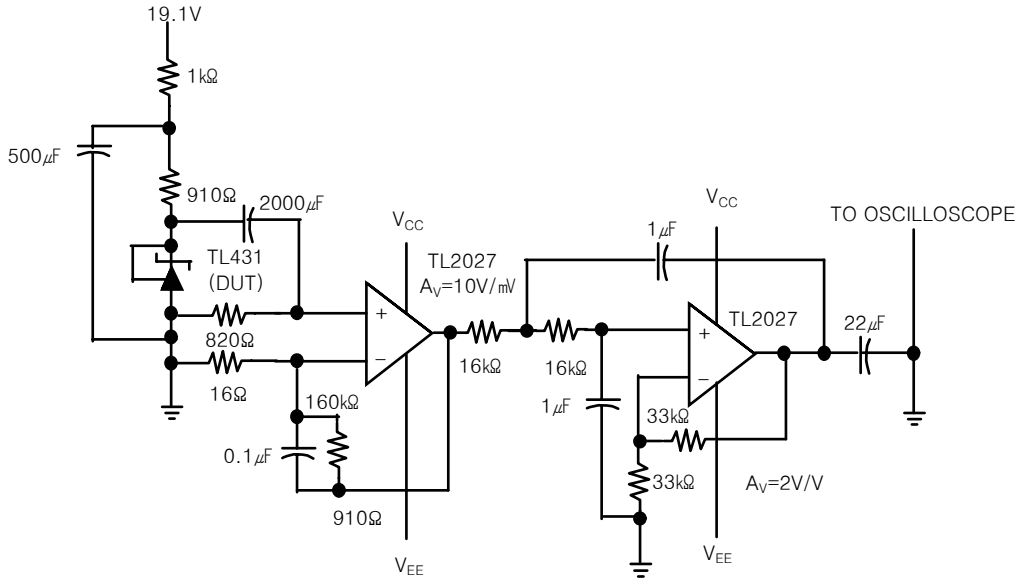

Figure 11. Test Circuit for Equivalent Input Noise Voltage

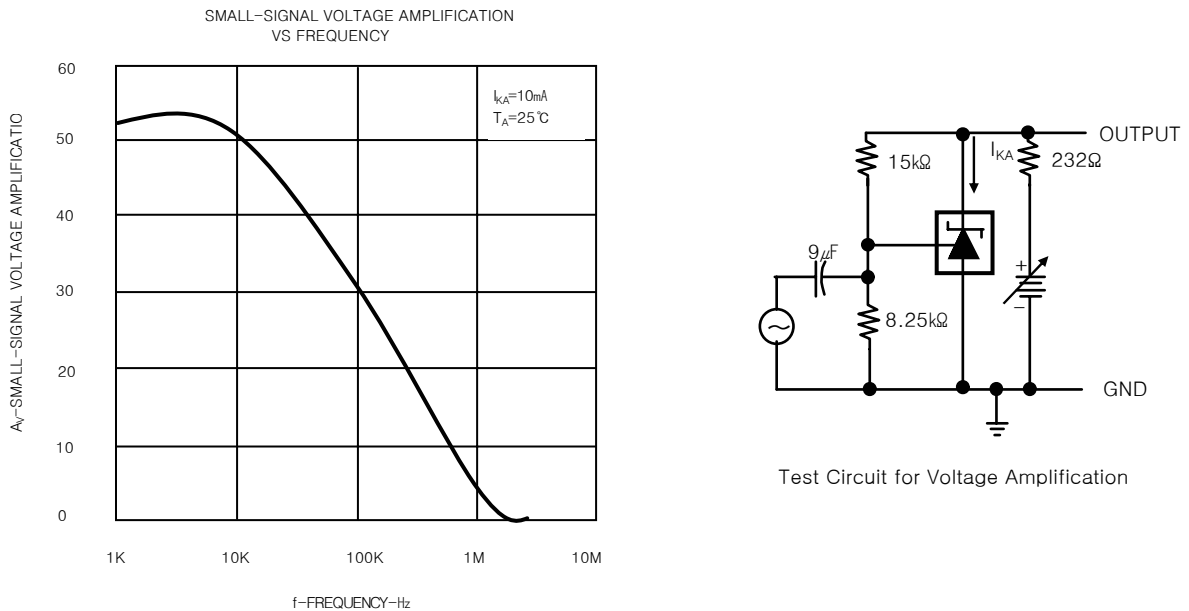
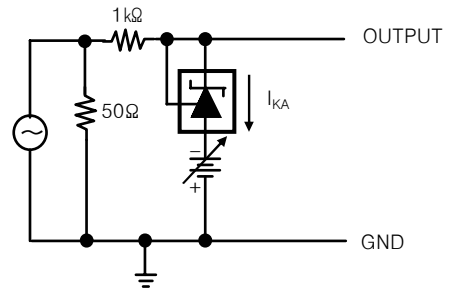
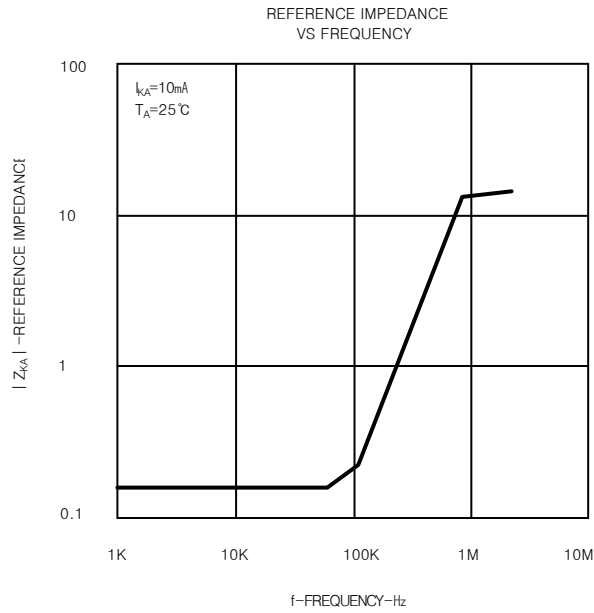

Figure 12.

TYPICAL PERFORMANCE CHARACTERISTICS



Test Circuit for Reference Impedance

Figure 13.

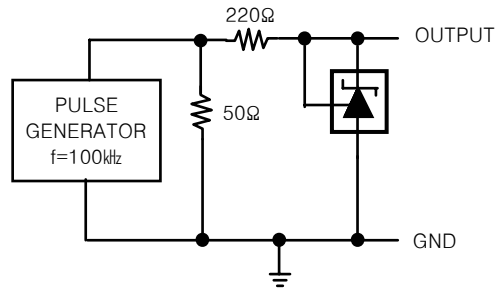
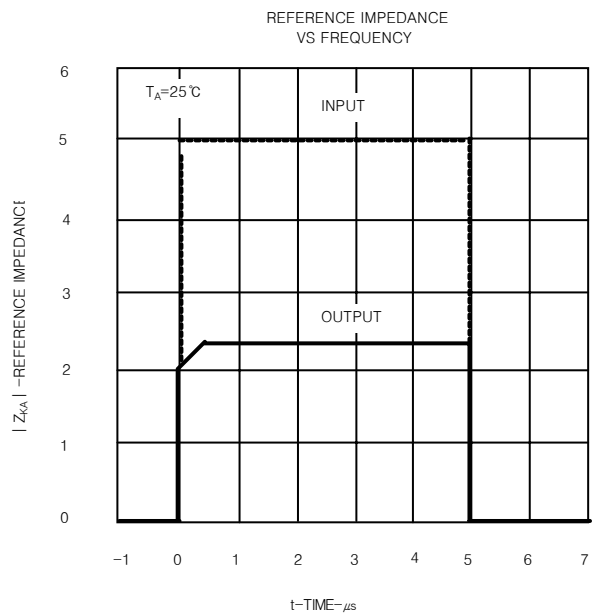

Test Circuit for Pulse Response

Figure 14.

APPLICATION INFORMATION

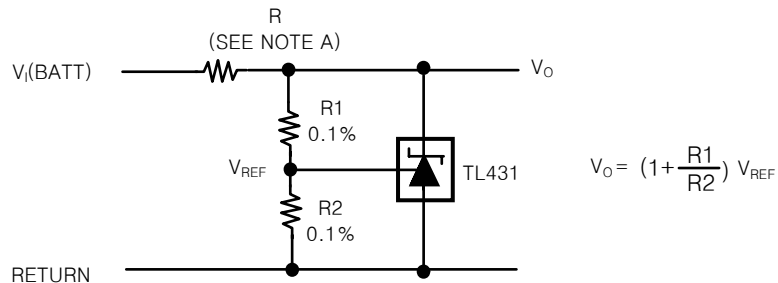

NOTE A : R Should provide cathode current  $\geq 1\text{mA}$  to the TL431 at minimum  $V_i(\text{BATT})$

Figure 15. Shunt Regulator

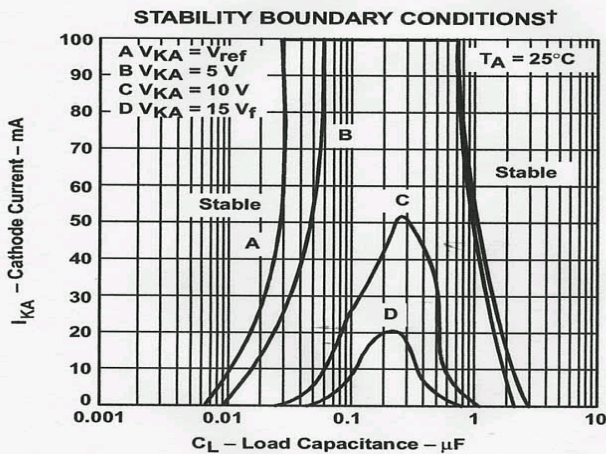

† The areas under the curves represent conditions that may cause the device to oscillate. For curves B, C, and D,  $R_2$  and  $V_+$  were adjusted to establish the initial  $V_{KA}$  and  $I_{KA}$  conditions with  $C_L = 0$ .  $V_{BATT}$  and  $C_L$  then were adjusted to determine the ranges of stability.

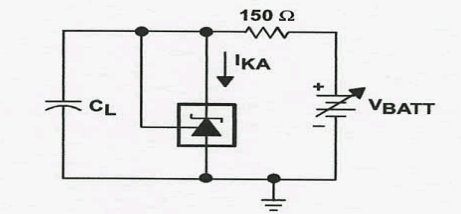

TEST CIRCUIT FOR CURVE A

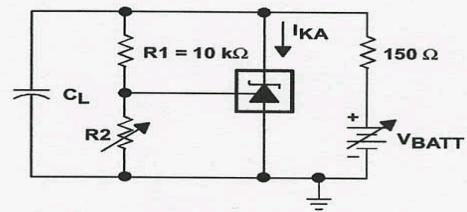

TEST CIRCUIT FOR CURVES B, C, AND D

Figure 16

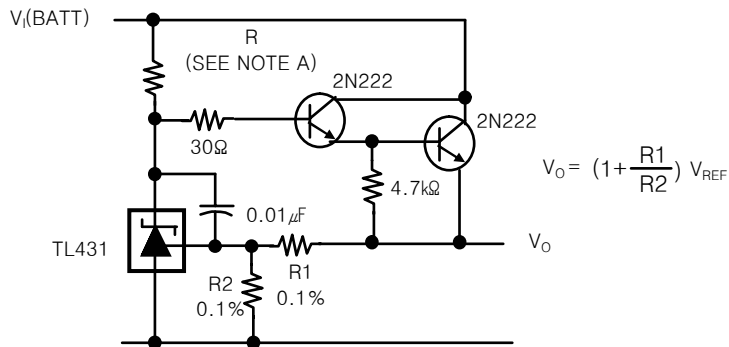

NOTE A : R Should provide cathode current  $\geq 1\text{mA}$  to the TL431 at minimum  $V_i(\text{BATT})$

Figure 17. Precision High-Current Series Regulator



APPLICATION INFORMATION

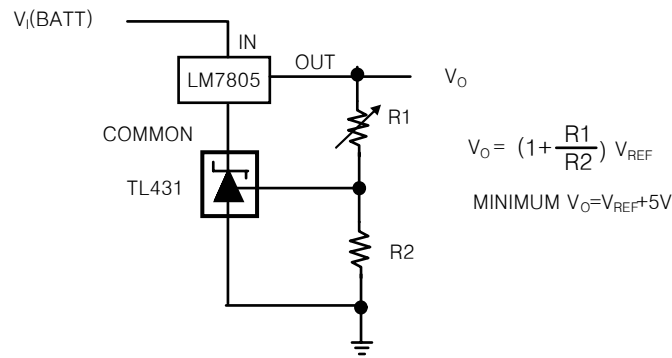

Figure 18. Output Control of a 3-Terminal Fixed Regulator

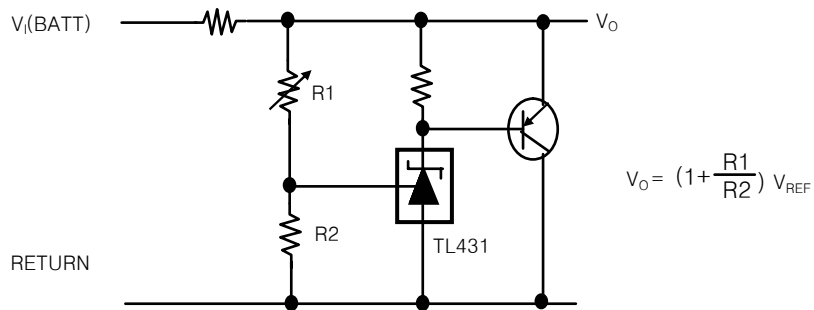
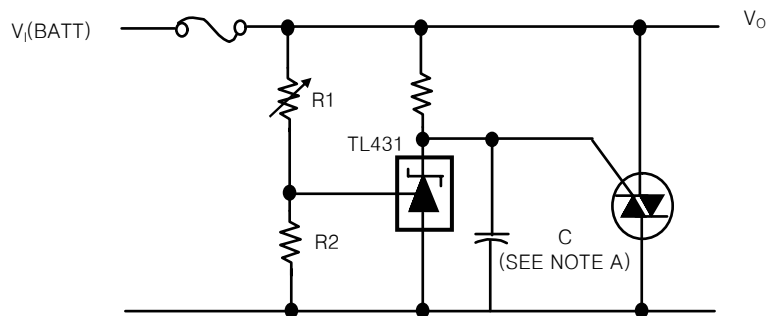

Figure 19. High-Current Shunt Regulator



NOTE A : Refer to the stability boundary conditions in Figure 16 to determine allowable values for C.

Figure 20. Crowbar Circuit

APPLICATION INFORMATION

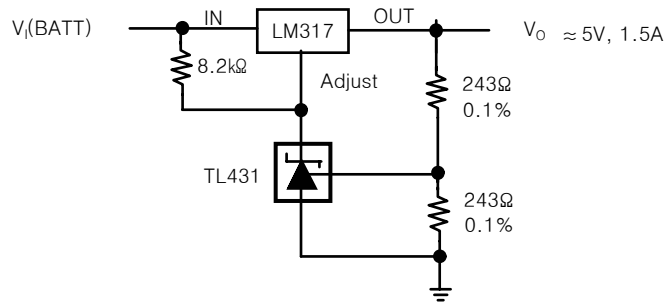
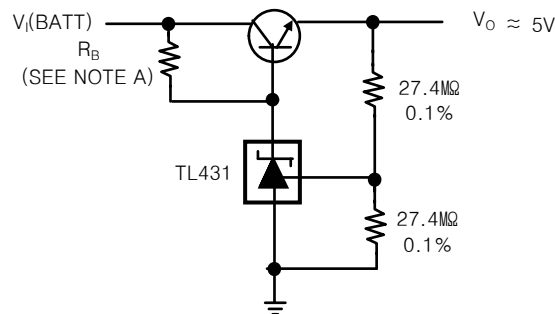

Figure 21. Precision 5-V 1.5A Regulator



NOTE A :  $R_B$  Should provide cathode current  $\geq 1\text{mA}$  to the TL431.

Figure 22. Efficient 5-V Precision Regulator

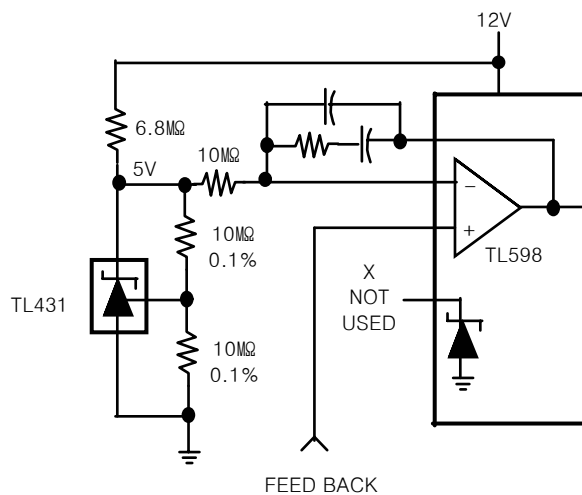
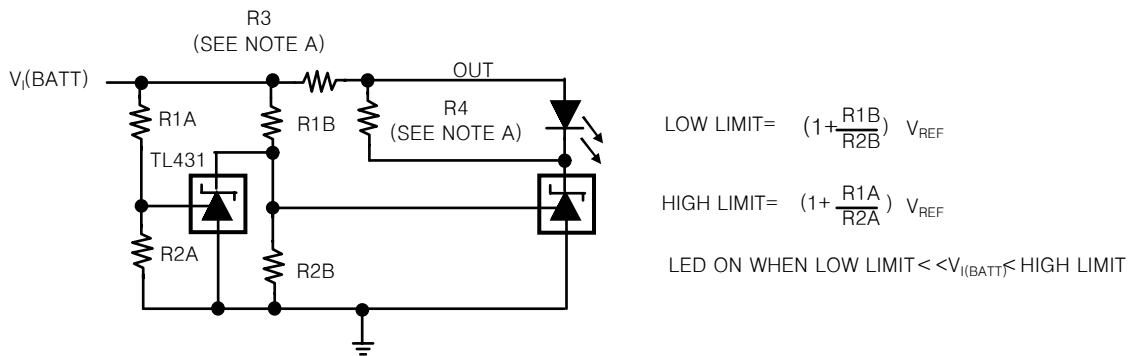

Figure 23. PWM Converter With Reference

APPLICATION INFORMATION



NOTE A : R3 and R4 are selected to provide the desired LED intensity and cathode current  $\geq 1\text{ mA}$  to the TL431 at the available  $V_{I(BATT)}$ .

Figure 24. Voltage Monitor

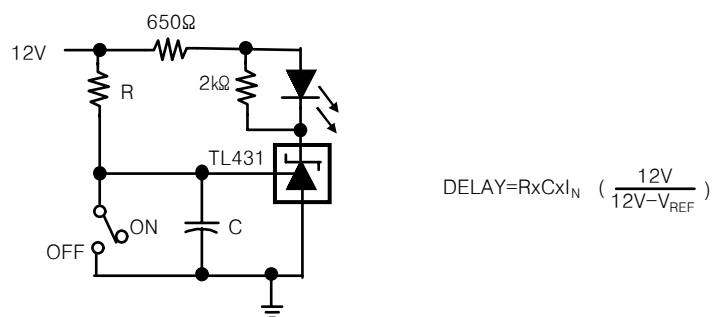

Figure 25. Delay Timer

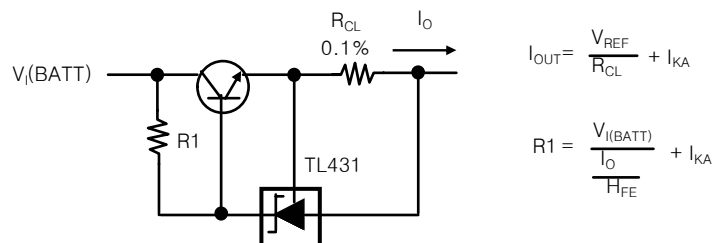

Figure 26. Precision Current Limiter

## APPLICATION INFORMATION

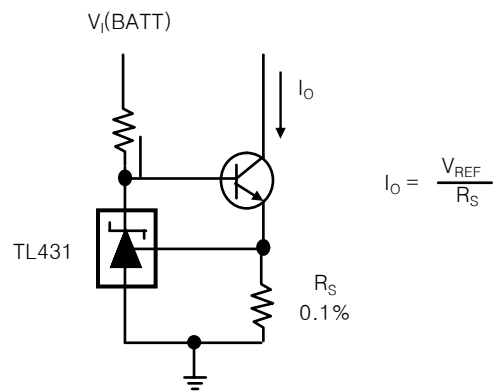
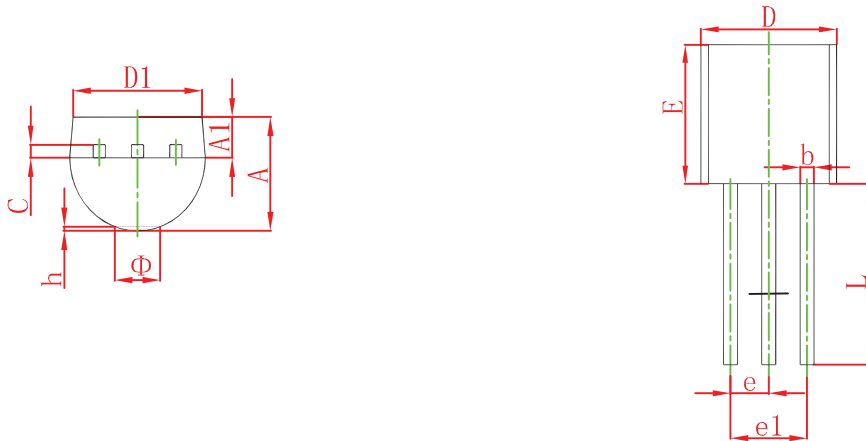

Figure 27. Precision Constant-Current Sink

TO-92 Package Outline Dimensions



Symbol	Dimensions In Millimeters		Dimensions In Inches	
	Min	Max	Min	Max
A	3.300	3.700	0.130	0.146
A1	1.100	1.400	0.043	0.055
b	0.380	0.550	0.015	0.022
c	0.360	0.510	0.014	0.020
D	4.300	4.700	0.169	0.185
D1	3.430		0.135	
E	4.300	4.700	0.169	0.185
e	1.270 TYP		0.050 TYP	
e1	2.440	2.640	0.096	0.104
L	14.100	14.500	0.555	0.571
Φ		1.600		0.063
h	0.000	0.380	0.000	0.015

TO-92 Suggested Pad Layout

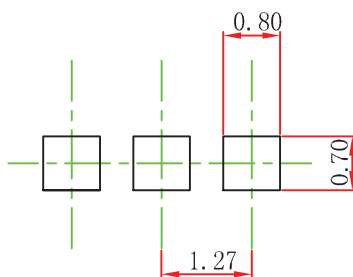

Note:

1. Controlling dimension: in millimeters.
2. General tolerance:  $\pm 0.05$ mm.
3. The pad layout is for reference purposes only.

**SOT-23 Package Outline Dimensions**

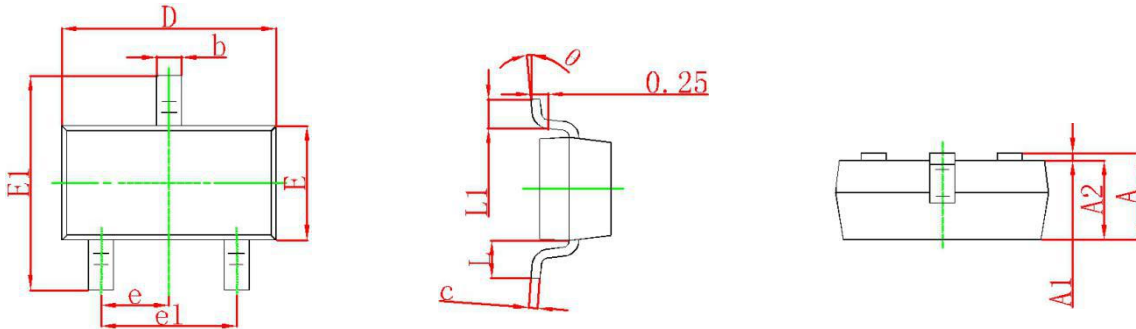

Symbol	Dimensions In Millimeters		Dimensions In Inches	
	Min	Max	Min	Max
A	0.900	1.150	0.035	0.045
A1	0.000	0.100	0.000	0.004
A2	0.900	1.050	0.035	0.041
b	0.300	0.500	0.012	0.020
c	0.080	0.150	0.003	0.006
D	2.800	3.000	0.110	0.118
E	1.200	1.400	0.047	0.055
E1	2.250	2.550	0.089	0.100
e	0.950 TYP		0.037 TYP	
e1	1.800	2.000	0.071	0.079
L	0.550 REF		0.022 REF	
L1	0.300	0.500	0.012	0.020
θ	0°	8°	0°	8°

**SOT-23 Suggested Pad Layout**

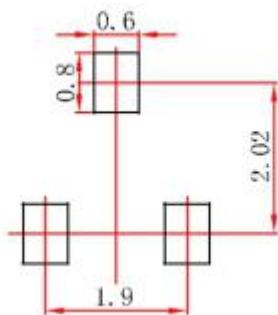

- Note:
1. Controlling dimension: in millimeters.
  2. General tolerance:  $\pm 0.05\text{mm}$ .
  3. The pad layout is for reference purposes only.

**SOT-89-3L Package Outline Dimensions**

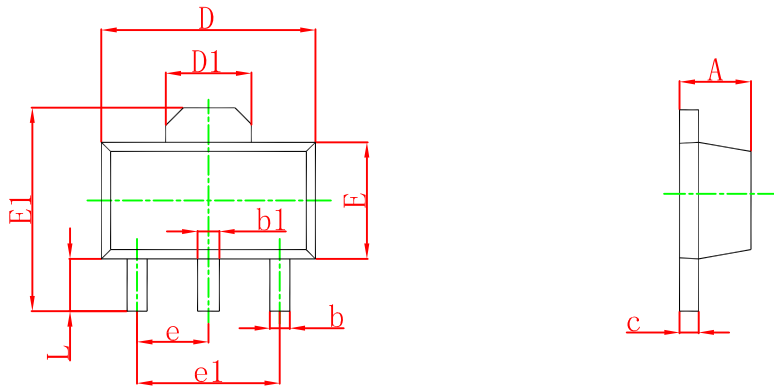

Symbol	Dimensions In Millimeters		Dimensions In Inches	
	Min	Max	Min	Max
A	1.400	1.600	0.055	0.063
b	0.320	0.520	0.013	0.020
b1	0.400	0.580	0.016	0.023
c	0.350	0.440	0.014	0.017
D	4.400	4.600	0.173	0.181
D1	1.550 REF.		0.061 REF.	
E	2.300	2.600	0.091	0.102
E1	3.940	4.250	0.155	0.167
e	1.500 TYP.		0.060 TYP.	
e1	3.000 TYP.		0.118 TYP.	
L	0.900	1.200	0.035	0.047

**SOT-89-3L Suggested Pad Layout**

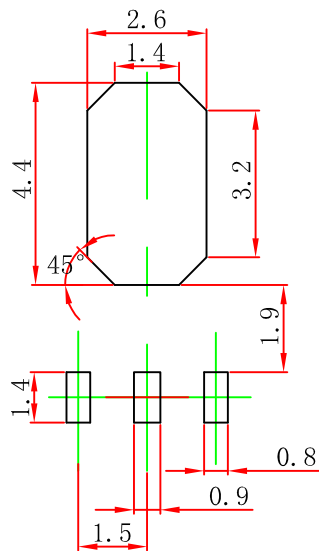

- Note:
1. Controlling dimension: in millimeters.
  2. General tolerance:  $\pm 0.05$  mm.
  3. The pad layout is for reference purposes only.

单击下面可查看定价，库存，交付和生命周期等信息

[>>DIOS\(迪恩思\)](#)