

## Technical Data Sheet-Preliminary

### TOP View LEDs

**67-11/GHC-XU2V2E/2T**

#### Features

- .P-LCC-2 package.
- .White package.
- .Optical indicator.
- .Colorless clear window.
- .Wide viewing angle.
- .Suitable for vapor-phase reflow.
- .Computable with automatic placement equipment.
- .Available on tape and reel (8mm Tape).
- .Pb-free.
  - ESD protection.



#### Descriptions

- • The 67-11 series is available in soft orange, green, blue and yellow. Due to the package design, the LED has wide viewing angle and optimized light coupling by inter reflector. This feature makes the SMT TOP LED ideal for light pipe application. The low current requirement makes this device ideal for portable equipment or any other application where power is at a premium.

#### Applications

- .Telecommunication: indicator and backlighting in telephone and fax.
- .Flat backlight for LCD, switch and symbol.
- .Light pipe application.
- .General use.

#### Device Selection Guide

Chip		Lens Color
Material	Emitted Color	
InGaN	Brilliant Green	Water Clear

## Technical Data Sheet-Preliminary TOP View LEDs

**67-11/GHC-XU2V2E/2T**

### Package Dimensions

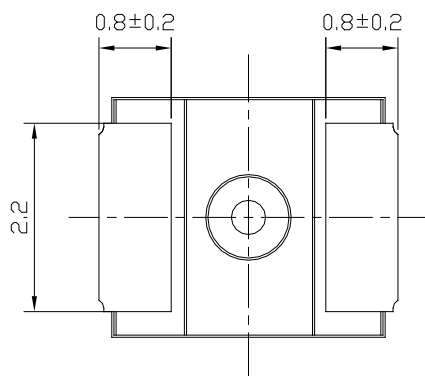
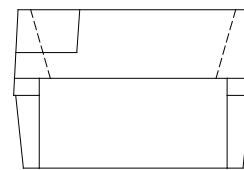
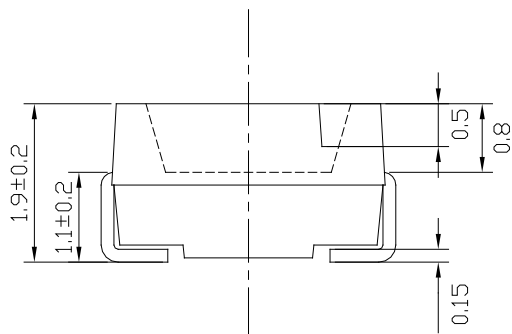
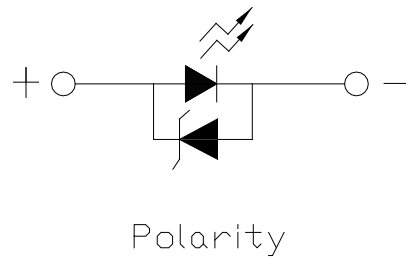
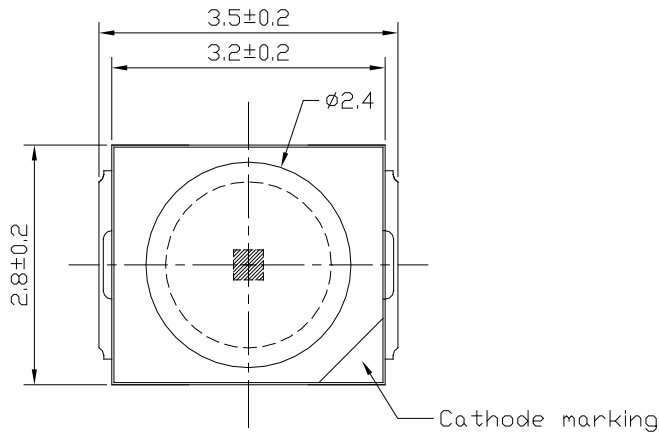

Recommended Solder Pad

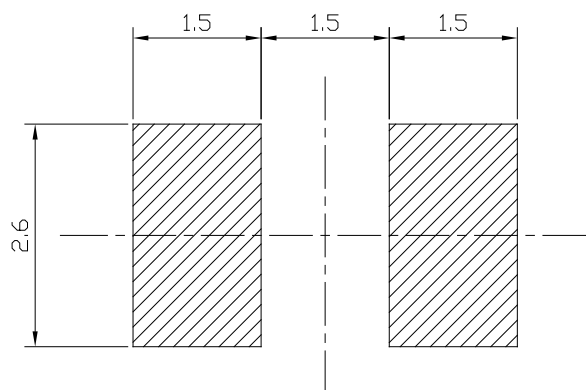

**Note: The tolerances unless mentioned is  $\pm 0.1$ mm; Unit = mm**

# Technical Data Sheet-Preliminary

## TOP View LEDs

**67-11/GHC-XU2V2E/2T**

### Absolute Maximum Ratings (Ta=25°C)

Parameter	Symbol	Rating	Unit
Reverse Voltage	V <sub>R</sub>	5	V
Forward Current	I <sub>F</sub>	25	mA
Peak Forward Current (Duty 1/10 @1KHz)	I <sub>FP</sub>	100	mA
Power Dissipation	P <sub>d</sub>	95	mW
Electrostatic Discharge(HBM)	ESD	2000	V
Operating Temperature	T <sub>opr</sub>	-40 ~ +85	°C
Storage Temperature	T <sub>stg</sub>	-40 ~ +90	°C
Soldering Temperature	T <sub>sol</sub>	Reflow Soldering : 260 °C for 10 sec. Hand Soldering : 350 °C for 3 sec.	

### Electro-Optical Characteristics (Ta=25°C)

Parameter	Symbol	Min.	Typ.	Max.	Unit	Condition
Luminous intensity	I <sub>v</sub>	360	-----	900	mcd	I <sub>F</sub> =20mA
Viewing Angle	2θ 1/2	-----	120	-----	deg	I <sub>F</sub> =20mA
Peak Wavelength	λ <sub>p</sub>	-----	518	-----	nm	I <sub>F</sub> =20mA
Dominant Wavelength	λ <sub>d</sub>	517.5	-----	535.5	nm	I <sub>F</sub> =20mA
Spectrum Radiation Bandwidth	△λ	-----	35	-----	nm	I <sub>F</sub> =20mA

#### Notes:

- 1.Tolerance of Luminous Intensity ±11%
- 2.Tolerance of Dominant Wavelength ±1nm
- 3.Tolerance of Forward Voltage ±0.1V

## Technical Data Sheet-Preliminary TOP View LEDs

**67-11/GHC-XU2V2E/2T**

### Bin Range Of Dominant Wavelength

Group	Bin Code	Min.	Max.	Unit	Condition
A	B10	517.5	519.5	nm	I <sub>F</sub> =20mA
	B11	519.5	521.5		
	B12	521.5	523.5		
	B13	523.5	525.5		
	B14	525.5	527.5		
	B15	527.5	529.5		
	B16	529.5	531.5		
	B17	531.5	533.5		
	B18	533.5	535.5		

### Bin Range Of Luminous Intensity

Bin	Min	Max	Unit	Condition
T2	360	450	mcd	I <sub>F</sub> =20mA
U1	450	565		
U2	565	715		
V1	715	900		

#### Notes:

- 1.Tolerance of Luminous Intensity  $\pm 11\%$
- 2.Tolerance of Dominant Wavelength  $\pm 1\text{nm}$
- 3.Tolerance of Forward Voltage  $\pm 0.1\text{V}$

## Technical Data Sheet-Preliminary TOP View LEDs

### 67-11/GHC-XU2V2E/2T

#### Typical Electro-Optical Characteristics Curves

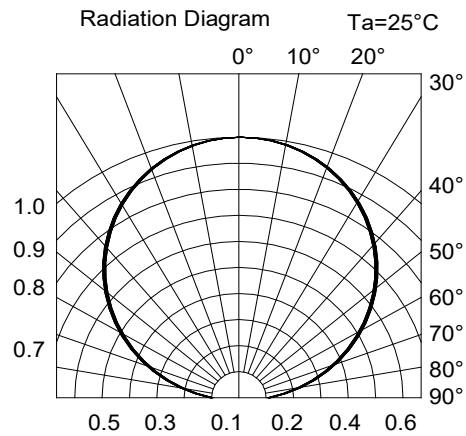
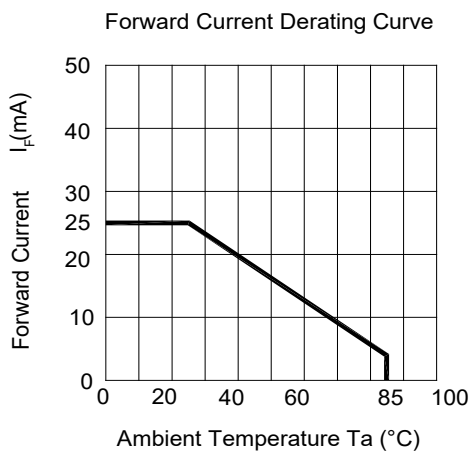
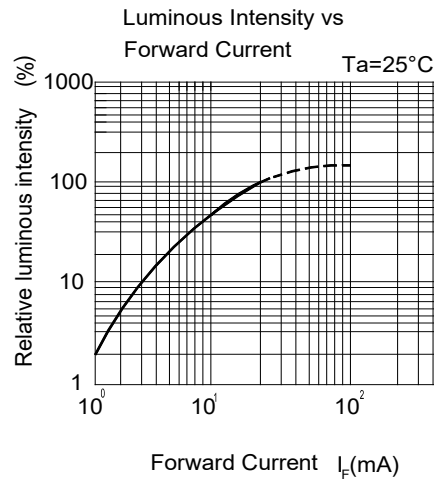
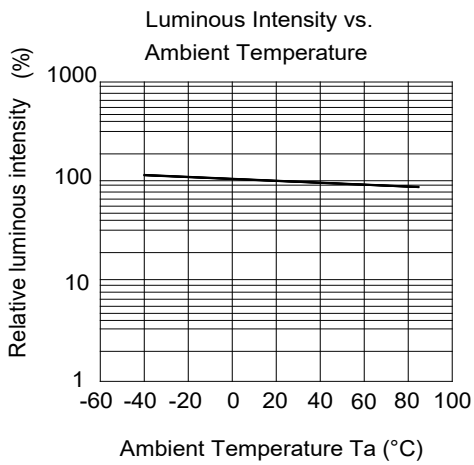
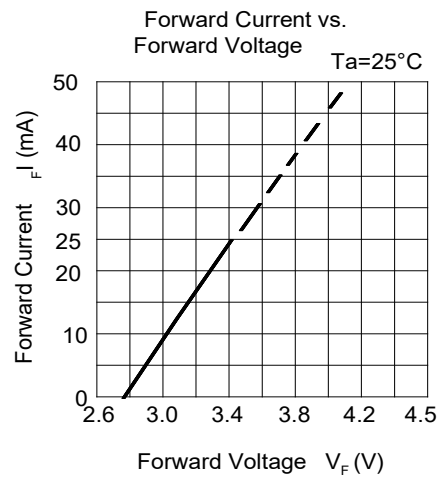
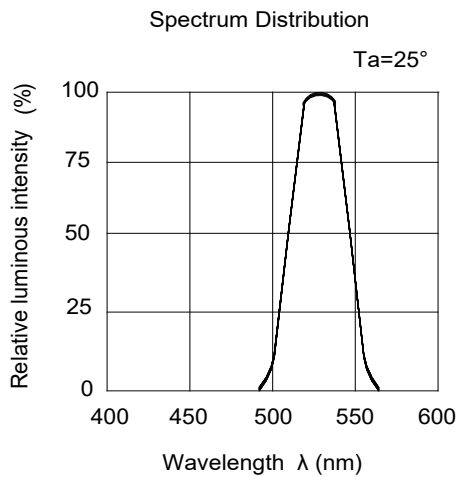

## Technical Data Sheet-Preliminary TOP View LEDs

**67-11/GHC-XU2V2E/2T**

### Label Explanation

CAT: Luminous Intensity Rank

HUE: Dom. Wavelength Rank

REF: Forward Voltage Rank

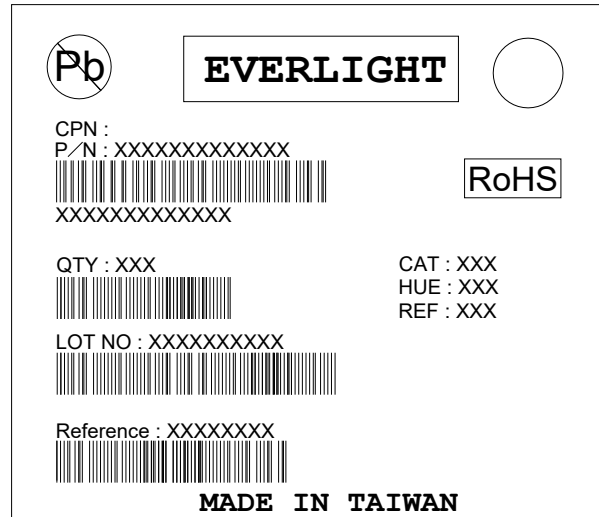

### Reel Dimensions

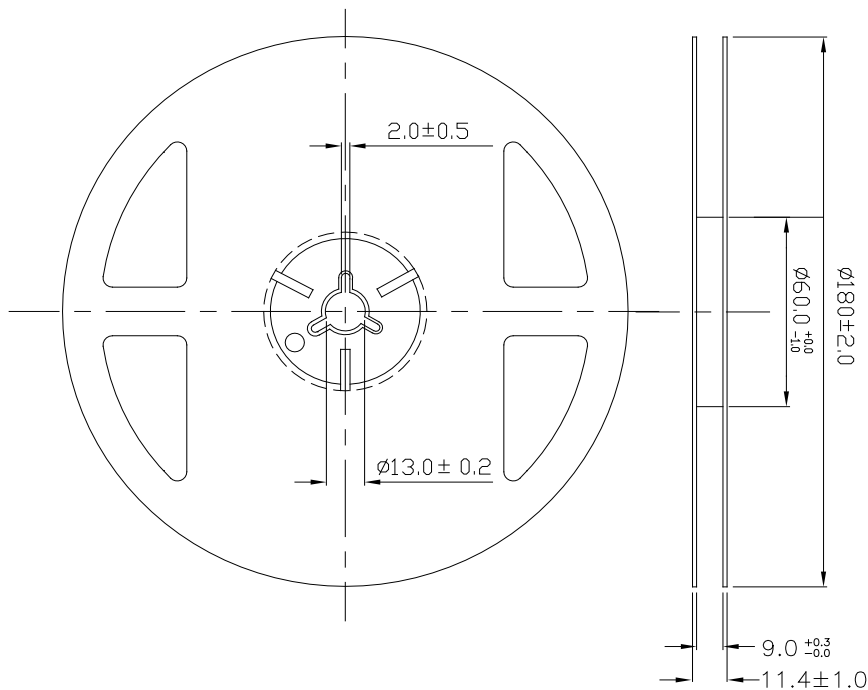

**Note:** The tolerances unless mentioned is  $\pm 0.1\text{mm}$ , Unit = mm

## Technical Data Sheet-Preliminary TOP View LEDs

**67-11/GHC-XU2V2E/2T**

**Carrier Tape Dimensions: Loaded quantity 2000 PCS per reel.**

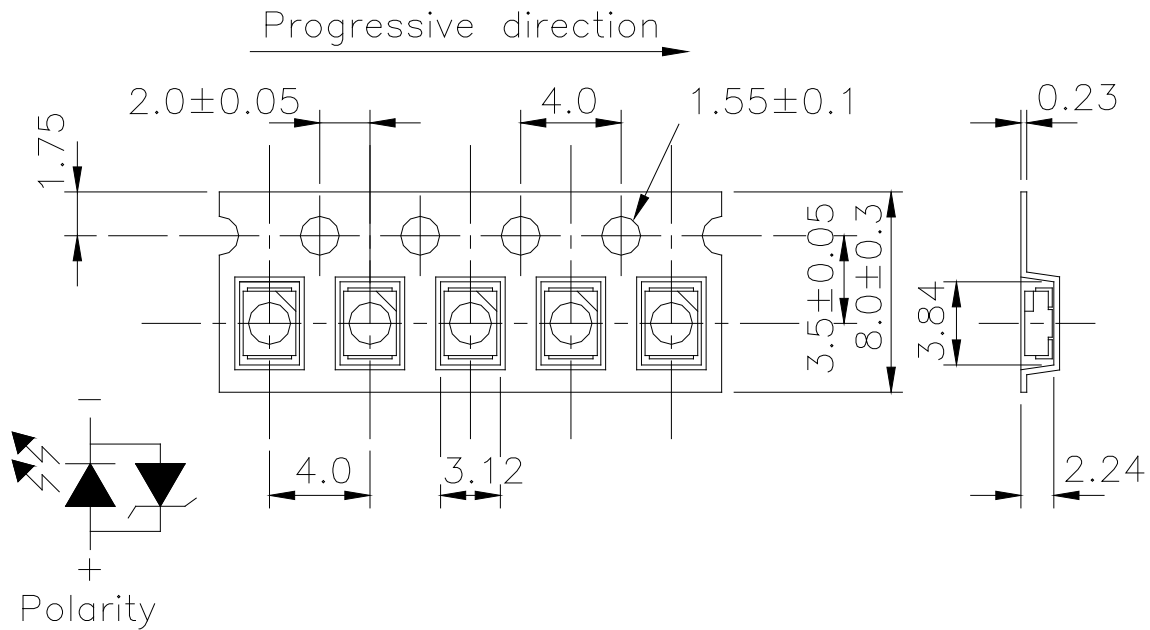

### Note:

1. Tolerances Unless Dimension ±0.1mm, Unit = mm
2. Minimum packing amount is 250/500/1000/2000 pcs per reel.

### Moisture Resistant Packaging

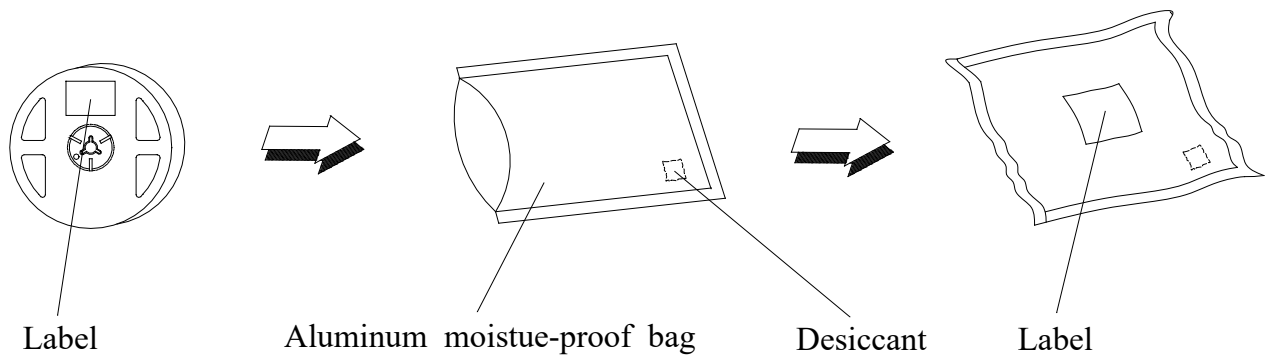

# Technical Data Sheet-Preliminary

## TOP View LEDs

**67-11/GHC-XU2V2E/2T**

### Reliability Test Items And Conditions

The reliability of products shall be satisfied with items listed below.

Confidence level : 90%

LTPD : 10%

No.	Items	Test Condition	Test Hours/Cycles	Sample Size	Ac/Re
1	Reflow Soldering	Temp. : 260°C ±5°C Min. 10sec.	6 Min.	22 PCS.	0/1
2	Temperature Cycle	H : +100°C 15min § 5 min L : -40°C 15min	300 Cycles	22 PCS.	0/1
3	Thermal Shock	H : +100°C 5min § 10 sec L : -10°C 5min	300 Cycles	22 PCS.	0/1
4	High Temperature Storage	Temp. : 100°C	1000 Hrs.	22 PCS.	0/1
5	Low Temperature Storage	Temp. : -40°C	1000 Hrs.	22 PCS.	0/1
6	DC Operating Life	IF = 20 mA	1000 Hrs.	22 PCS.	0/1
7	High Temperature / High Humidity	85°C / 85%RH	1000 Hrs.	22 PCS.	0/1



## Technical Data Sheet-Preliminary TOP View LEDs

**67-11/GHC-XU2V2E/2T**

### Precautions For Use

#### 1. Over-current-proof

Customer must apply resistors for protection, otherwise slight voltage shift will cause big current change ( Burn out will happen ).

#### 2. Storage

2.1 Do not open moisture proof bag before the products are ready to use.

2.2 Before opening the package: The LEDs should be kept at 30°C or less and 90%RH or less.

2.3 After opening the package: The LED's floor life are 168 hours under 30°C or less and 60% RH or less.

If unused LEDs remain, it should be stored in moisture proof packages.

2.4 If the moisture absorbent material (silica gel) has faded away or the LEDs have exceeded the storage time, baking treatment should be performed using the following conditions.

Baking treatment : 60±5°C for 24 hours.

#### 3. Soldering Condition

##### 3.1 Pb-free solder temperature profile

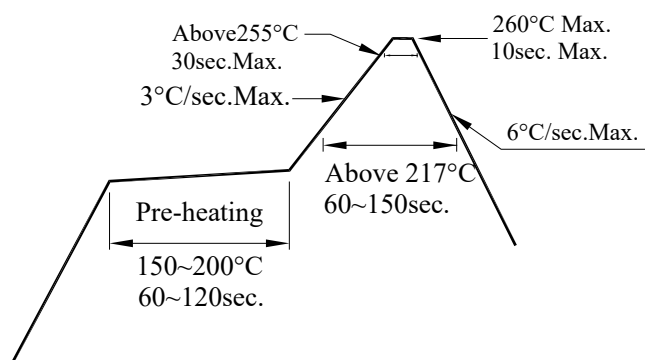

3.2 Reflow soldering should not be done more than two times.

3.3 When soldering, do not put stress on the LEDs during heating.

3.4 After soldering, do not warp the circuit board.

## Technical Data Sheet-Preliminary

### TOP View LEDs

---

**67-11/GHC-XU2V2E/2T**

#### 4. Soldering Iron

Each terminal is to go to the tip of soldering iron temperature less than 350°C for 3 seconds within once in less than the soldering iron capacity 25W. Leave two seconds and more intervals, and do soldering of each terminal. Be careful because the damage of the product is often started at the time of the hand solder.

#### 5. Repairing

Repair should not be done after the LEDs have been soldered. When repairing is unavoidable, a double-head soldering iron should be used (as below figure). It should be confirmed beforehand whether the characteristics of the LEDs will or will not be damaged by repairing.

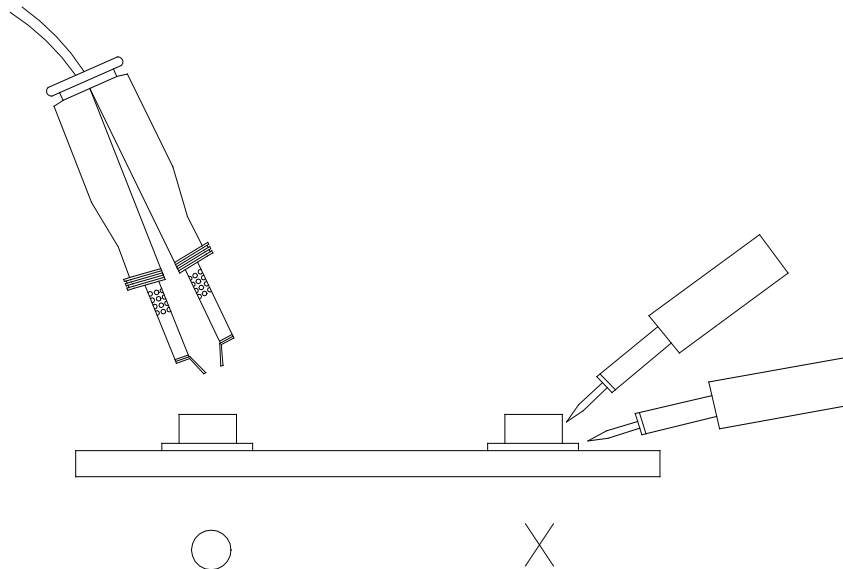

## Technical Data Sheet-Preliminary TOP View LEDs

---

**67-11/GHC-XU2V2E/2T**

### **DISCLAIMER**

1. EVERLIGHT reserves the right(s) on the adjustment of product material mix for the specification.
2. The product meets EVERLIGHT published specification for a period of twelve (12) months from date of shipment.
3. The graphs shown in this datasheet are representing typical data only and do not show guaranteed values.
4. When using this product, please observe the absolute maximum ratings and the instructions for using outlined in these specification sheets. EVERLIGHT assumes no responsibility for any damage resulting from the use of the product which does not comply with the absolute maximum ratings and the instructions included in these specification sheets.
5. These specification sheets include materials protected under copyright of EVERLIGHT. Reproduction in any form is prohibited without obtaining EVERLIGHT's prior consent.
6. This product is not intended to be used for military, aircraft, automotive, medical, life sustaining or life saving applications or any other application which can result in human injury or death. Please contact authorized Everlight sales agent for special application request.

单击下面可查看定价，库存，交付和生命周期等信息

[>>Everlight \(亿光\)](#)