

SMD ■ REFLECTOR 67-03A/R6GHBHW-A01/2T/MS



Features

- Package in 8 mm tape on 7" diameter reel
- Compatible with automatic placement equipment
- Various Compatible with infrared and vapor phase reflow solder process
- 4 Pins for separate control of each chip and better thermal management
- Good color fidelity and brightness uniformity across the viewing angle
- Pb-free
- RoHS compliant

Description

- The 67-03A SMD LED package provides a perfect solution when users need a clear view of signage display with any size board with 3 in 1 full color SMD LEDs which offer smaller pixel pitch between two LEDs to create a high resolution and better contrast with its black surface design.

Applications

- Indoor signage display applications
- Indicator and backlighting for all consumer electronics.
- Gaming equipment.
- General use.

Device Selection Guide

Chip Materials	Emitted Color	Resin Color
AlGaInP	Brilliant Red	Water Diffuse
InGaN	Brilliant Green	
InGaN	Brilliant Blue	

Absolute Maximum Ratings (Ta=25 °C)

Parameter	Symbol	Rating	Unit
Reverse Voltage	VR	5	V
Forward Current	IF	R:25 G:25 B:25	mA
Peak Forward Current (Duty 1/10 @1KHz)	IFP	R:60 G:100 B:100	mA
Power Dissipation	Pd	R:60 G:95 B:95	mW
Junction Temperature	Tj	100	
Operating Temperature	Topr	-40 ~ +85	
Storage Temperature	Tstg	-40 ~ +90	
ESD (Classification acc. AEC Q101)	ESDHBM	R:2000 G:150 B:150	V
Soldering Temperature	Tsol	Reflow Soldering : 260 for 10 sec. Hand Soldering : 350 for 3 sec.	

Electro-Optical Characteristics (Ta=25)

Parameter	Symbol	Min.	Typ.	Max.	Unit	Condition	
Luminous Intensity	Iv	R	165	-----	288	mcd	I _F =20mA
		G	650	-----	1350		
		B	150	-----	310		
Viewing Angle	2θ _{1/2}	-----	120	-----	deg	I _F =20mA	
Peak Wavelength	λ _p	R	-----	632	nm	I _F =20mA	
		G	-----	518			
		B	-----	468			
Dominant Wavelength	λ _d	R	620.5	-----	627.5	nm	I _F =20mA
		G	518.0	-----	533.0		
		B	461.5	-----	471.5		
Spectrum Radiation Bandwidth	Δλ	R	-----	20	nm	I _F =20mA	
		G	-----	35			
		B	-----	25			
Forward Voltage	V _F	R	1.7	-----	2.6	V	I _F =20mA
		G	2.7	-----	3.6		
		B	2.7	-----	3.6		
Reverse Current	I _R	-----	-----	10	μA	V _R =5V	

Note:

1. Tolerance of Luminous Intensity: ±10%
2. Tolerance of Dominant Wavelength: ±1nm
3. Tolerance of Forward Voltage: ±0.1V

Floating Bin(Red)
Bin Range of Luminous Intensity

Bin Code	Min.	Max.	Unit	Condition
RA	165	200	mcd	I _F =20mA
RB	200	240		
RC	240	288		

Bin Range of Dominant Wavelength

Bin Code	Min.	Max.	Unit	Condition
R1	620.5	627.5	nm	I _F =20mA

Floating Bin(Green)
Bin Range of Luminous Intensity

Bin Code	Min.	Max.	Unit	Condition
GA	650	785	mcd	I _F =20mA
GB	785	940		
GC	940	1130		
GD	1130	1350		

Bin Range of Dominant Wavelength

Bin Code	Min.	Max.	Unit	Condition
G1	518.0	523.0	nm	I _F =20mA
G2	523.0	528.0		
G3	528.0	533.0		

- Note:
- 1.Tolerance of Luminous Intensity: ±10%
 - 2.Tolerance of Dominant Wavelength: ±1nm

Bin Code	Min.	Max.	Unit	Condition
BA	150	180	mcd	I _F =20mA
BB	180	215		
BC	215	260		
BD	260	310		

Bin Range of Dominant Wavelength

Bin Code	Min.	Max.	Unit	Condition
B1	461.5	466.5	nm	I _F =20mA
B2	466.5	471.5		

Note:

1. Tolerance of Luminous Intensity: $\pm 10\%$
2. Tolerance of Dominant Wavelength: $\pm 1\text{nm}$

EVERLIGHT

Typical Electro-Optical Characteristics Curves

Spectrum Distribution

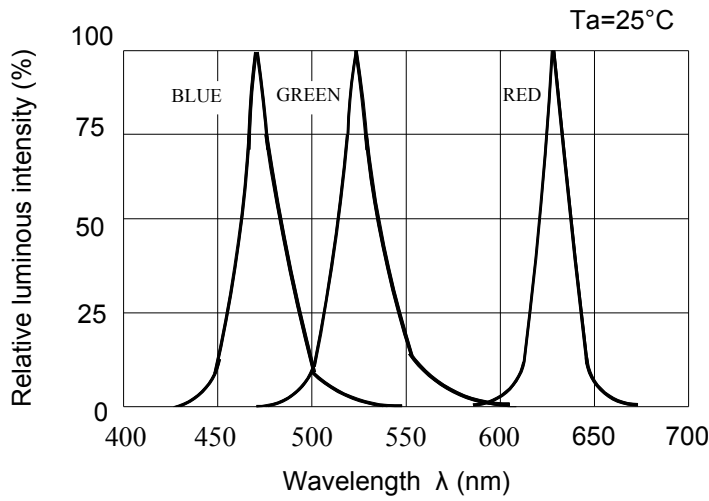

Forward Current vs. Forward Voltage

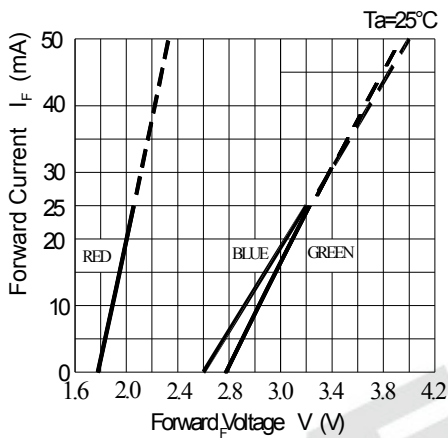

Forward Current Derating Curve

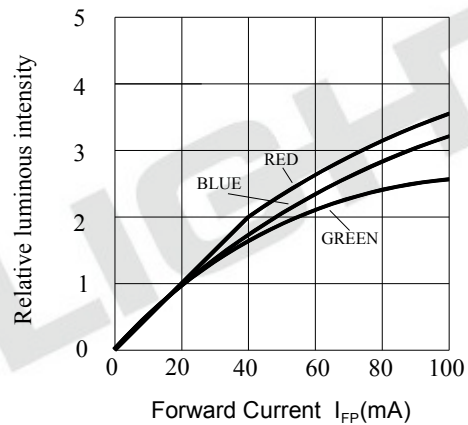

X-X

Radiation Diagram Ta=25°C

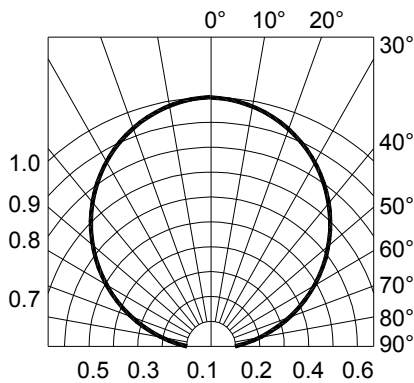

Y-Y

Radiation Diagram Ta=25°C

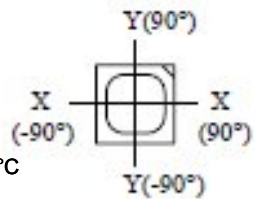
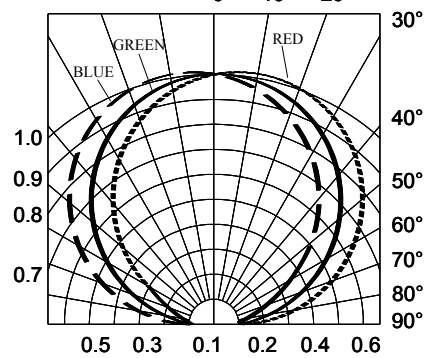

Typical Electro-Optical Characteristics Curves

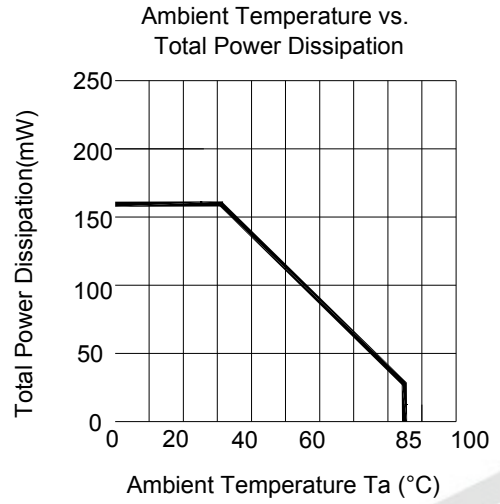
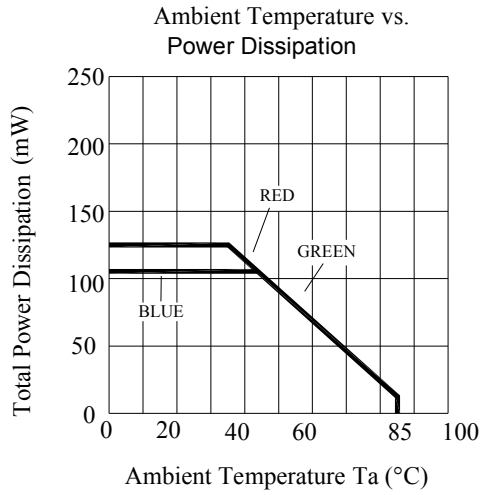

EVERLIGHT

Package Dimension

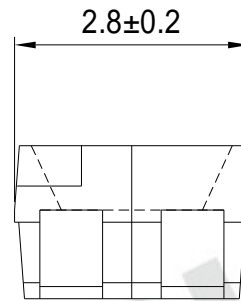
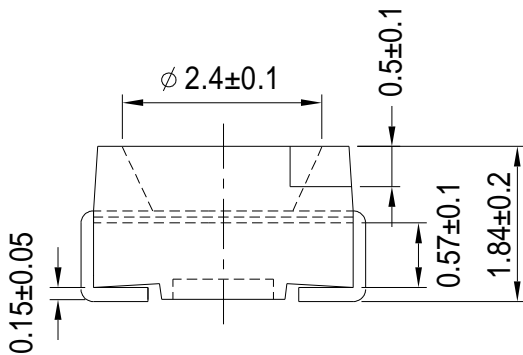
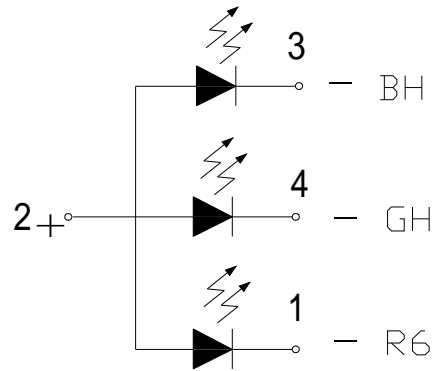
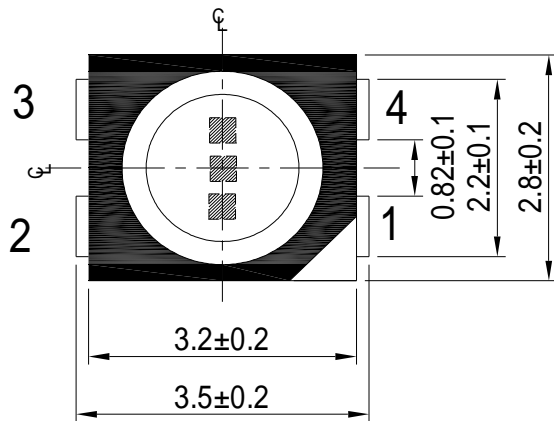

Recommended soldering pad design

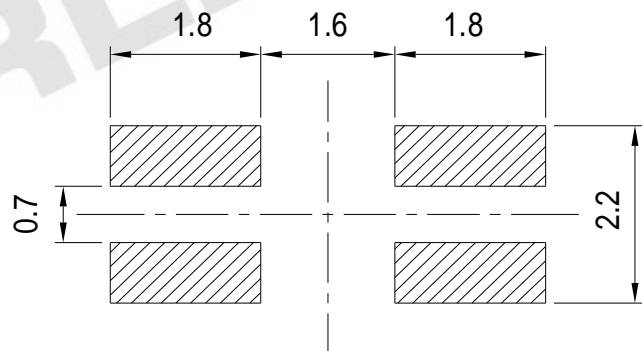
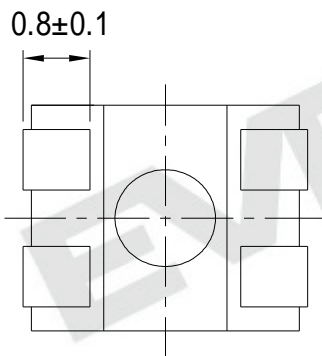

Note:

Tolerances unless mentioned ±0.1mm. Unit = mm

Moisture Resistant Packing Materials

Label Explanation

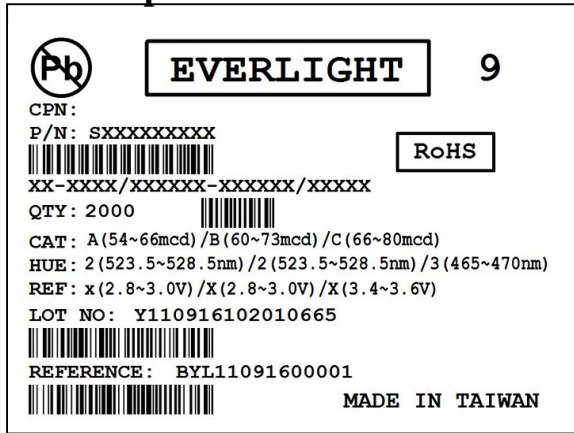

- CPN: Customer's Product Number
- P/N: Product Number
- QTY: Packing Quantity
- CAT: Luminous Intensity Rank
- HUE: Dom. Wavelength Rank
- REF: Forward Voltage Rank
- LOT No: Lot Number

Reel Dimensions

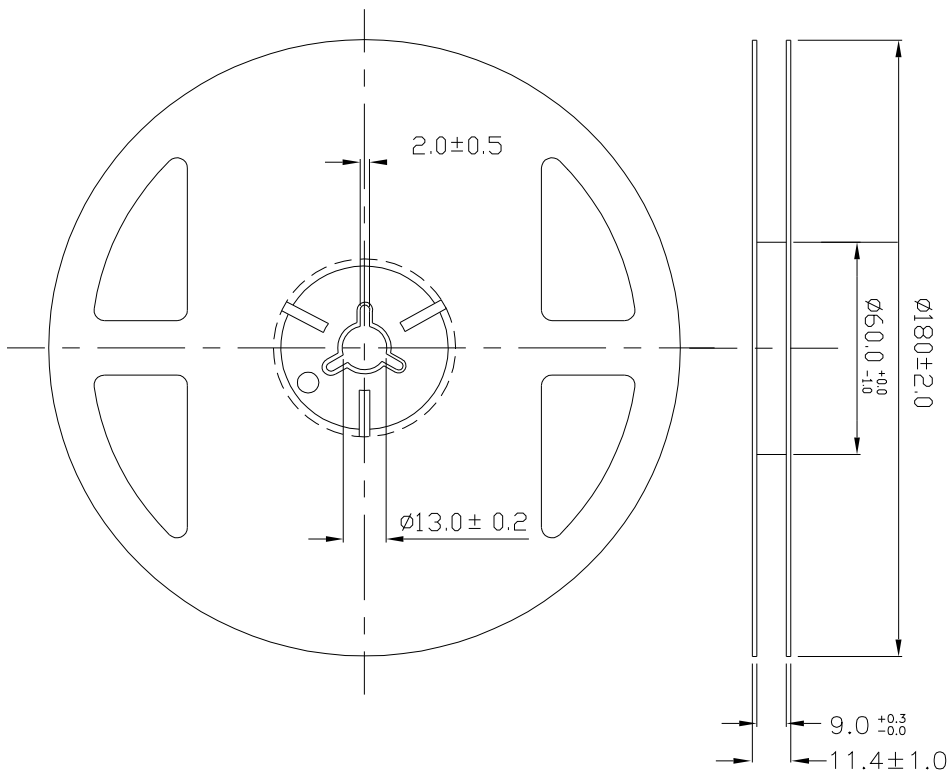

Carrier Tape Dimensions: Loaded Quantity 2000 pcs Per Reel

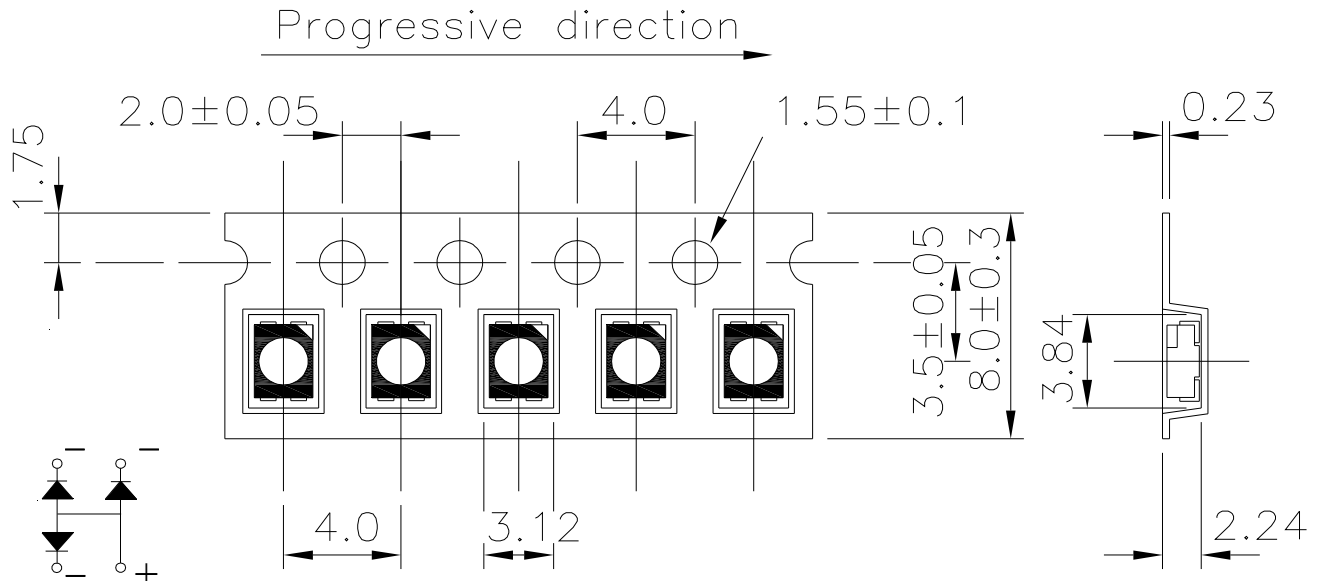

Note:
 Tolerances unless mentioned ± 0.1 mm. Unit = mm

Moisture Resistant Packing Process

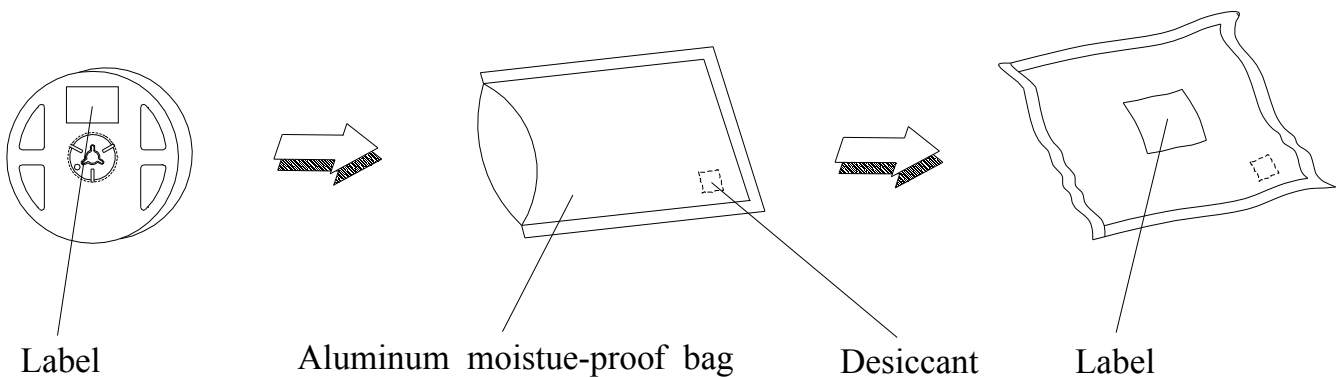

Note: Tolerances unless mentioned ± 0.1 mm. Unit = mm

Precautions for Use

1. Over-current-proof

Customer must apply resistors for protection, otherwise slight voltage shift will cause big current change (Burn out will happen).

2. Storage

2.1 Do not open moisture proof bag before the products are ready to use.

2.2 Before opening the package: The LEDs should be kept at 30 or less and 90%RH or less.

2.3 After opening the package: The LED's floor life is 168Hrs under 30 or less and 60% RH or less. If unused LEDs remain, it should be stored in moisture proof packages.

2.4 If the moisture absorbent material (silica gel) has faded away or the LEDs have exceeded the storage time, baking treatment should be performed using the following conditions.

Baking treatment : 60 ± 5 for 24 hours.

2.5 Before using LEDs, baking treatment should be implemented based on the following conditions: pre-curing at 60 ± 5 for 24 hours or 125 ± 5 for 3 hours.

3. Soldering Condition

3.1 Pb-free solder temperature profile

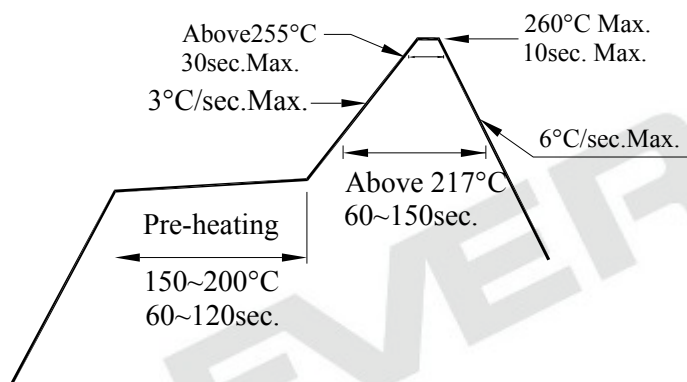

3.2 Reflow soldering should not be done more than two times.

3.3 When soldering, do not put stress on the LEDs during heating.

3.4 After soldering, do not warp the circuit board.

4. Soldering Iron

Each terminal is to go to the tip of soldering iron temperature less than 350 for 3 seconds within once in less than the soldering iron capacity 25W. Leave two seconds and more intervals, and do soldering of each terminal. Be careful because the damage of the product is often started at the time of the hand solder.

5.Repairing

Repair should not be done after the LEDs have been soldered. When repairing is unavoidable, a double-head soldering iron should be used (as below figure). It should be confirmed beforehand whether the characteristics of the LEDs will or will not be damaged by repairing.

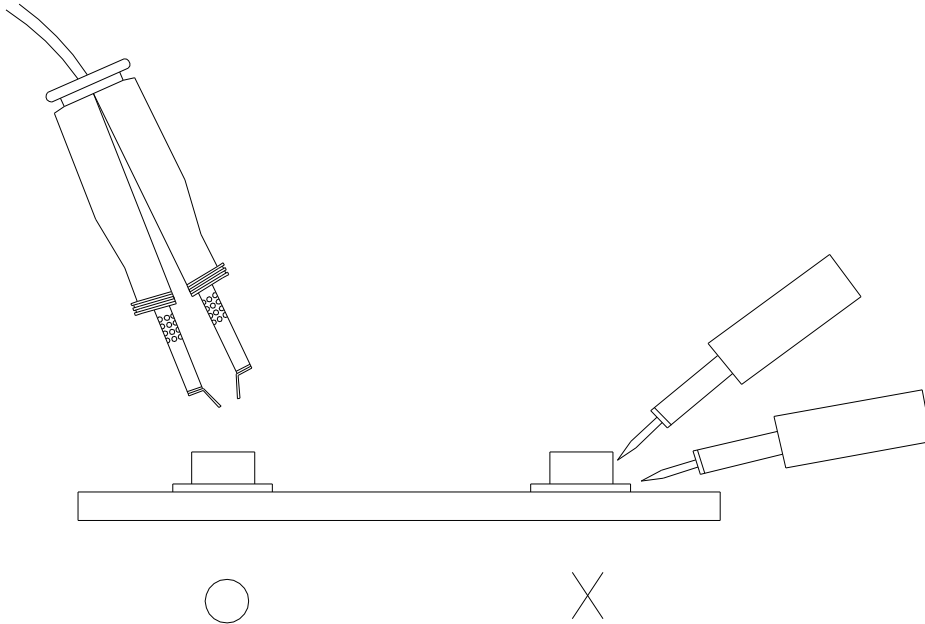

6.Directions for use

The LEDs should be operated with forward bias. The driving circuit must be designed so that the LEDs are not subjected to forward or reverse voltage while it is off. If reverse voltage is continuously applied to the LEDs, It may cause migration resulting in LED damage.

EVERLIGHT ELECTRONICS CO., LTD.
Office: No 6-8, Zhonghua Rd., Shulin Dist.,
New Taipei City 23860, Taiwan, R.O.C

Tel: 886-2-2685-6688
Fax: 886-2-2685-6699
<http://www.everlight.com>

单击下面可查看定价，库存，交付和生命周期等信息

[>>Everlight \(亿光\)](#)