

Power Top View LEDs 67-11U-NP56B64DBACB2638Z2-2T0T-AM



Features

Lead (Pb) Free Product - RoHS Compliant

- P-LCC-2 package.
- Colored diffused resin.
- Wide viewing angle 120°.
- Inner reflector and white package.
- Qualification according to AEC-Q101 rev C.
- Precondition: Bases on JEDEC J-STD 020D Level 3.
- Automotive reflow profile (IR reflow or wave soldering)

Applications

- Automotive Lighting Interior and Exterior.
- Signal and Symbol Luminary.
- Commercial and Industrial Illumination.
- Backlight: LCD, Switches, Push buttons.

Device Selection Guide

| Chip Materials | Emitted Color | Resin Color |
|----------------|---------------|-------------|
| InGaN | White | Yellowish |

Absolute Maximum Ratings (Ta=25)

| Parameter | Symbol | Rating | Unit |
|---|---------------|---|------|
| Forward Current | I_F | 60 | mA |
| Peak Forward Current (Duty 1/10 @1KHz) | I_{FP} | 100 | mA |
| Power Dissipation | P_d | 228 | mW |
| Junction Temperature | T_j | 115 | |
| Operating Temperature | T_{opr} | -40 ~ +100 | |
| Storage Temperature | T_{stg} | -40 ~ +110 | |
| Thermal Resistance | $R_{th\ J-A}$ | 250 | K/W |
| | $R_{th\ J-S}$ | 150 | K/W |
| ESD (Classification acc. AEC Q101) | ESD_{HBM} | 2000 | V |
| | ESD_{MM} | 200 | V |
| Soldering Temperature | T_{sol} | Reflow Soldering : 260 for 30 sec. Hand Soldering : 350 for 3 sec. | |

Electro-Optical Characteristics (Ta=25)

| Parameter | Symbol | Min. | Typ. | Max. | Unit | Condition |
|--------------------|-------------------|------|------|------|------|----------------------|
| Luminous Intensity | Iv | 1800 | --- | 4500 | mcd | I _F =20mA |
| Viewing Angle | 2θ _{1/2} | --- | 120 | --- | deg | |
| Forward Voltage | V _F | 2.6 | --- | 3.8 | V | |

Note:

1. Tolerance of Luminous Intensity: ±11%
2. Tolerance of Chromaticity Coordinates is ±0.01
3. Tolerance of Forward Voltage: ±0.1V

Bin Range of Luminous Intensity

| Bin Code | Min. | Max. | Unit | Condition |
|----------|------|------|------|----------------------|
| BA | 1800 | 2240 | mcd | I _F =20mA |
| BB | 2240 | 2800 | | |
| CA | 2800 | 3550 | | |
| CB | 3550 | 4500 | | |

Bin Range of Forward Voltage

| Bin Code | Min. | Max. | Unit | Condition |
|----------|------|------|------|----------------------|
| A6-1 | 2.60 | 2.80 | V | I _F =20mA |
| A6-2 | 2.80 | 3.00 | | |
| A6-3 | 3.00 | 3.20 | | |
| A6-4 | 3.20 | 3.40 | | |
| A6-5 | 3.40 | 3.60 | | |
| A6-6 | 3.60 | 3.80 | | |

The C.I.E. 1931 Chromaticity Diagram

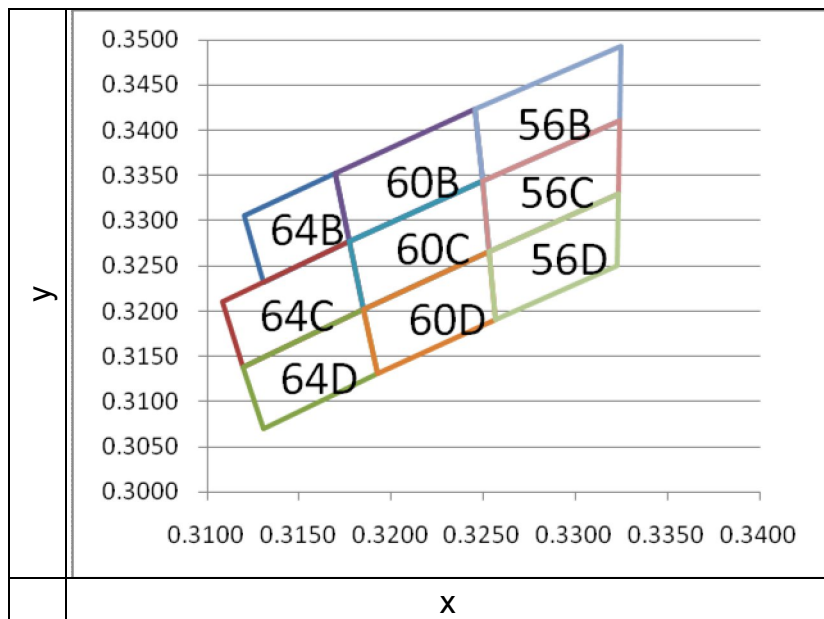

EVERLIGHT

Bin Range of Chromaticity Coordinates Specifications

| Bin Code | CIE_x | CIE_y | Condition |
|----------|--------|--------|----------------------|
| 64B | 0.312 | 0.3306 | I _F =20mA |
| | 0.3169 | 0.3353 | |
| | 0.3177 | 0.3277 | |
| | 0.3131 | 0.3232 | |
| 64C | 0.3109 | 0.3211 | |
| | 0.3177 | 0.3277 | |
| | 0.3185 | 0.3203 | |
| | 0.312 | 0.3139 | |
| 64D | 0.312 | 0.3139 | |
| | 0.3185 | 0.3203 | |
| | 0.3192 | 0.3131 | |
| | 0.3131 | 0.307 | |
| 60B | 0.3169 | 0.3353 | |
| | 0.3246 | 0.3424 | |
| | 0.3249 | 0.3344 | |
| | 0.3177 | 0.3277 | |
| 60C | 0.3177 | 0.3277 | |
| | 0.3249 | 0.3344 | |
| | 0.3253 | 0.3266 | |
| | 0.3185 | 0.3203 | |
| 60D | 0.3185 | 0.3203 | |
| | 0.3253 | 0.3266 | |
| | 0.3256 | 0.3191 | |
| | 0.3192 | 0.3131 | |
| 56B | 0.3246 | 0.3424 | |
| | 0.3325 | 0.3493 | |
| | 0.3324 | 0.341 | |
| | 0.3249 | 0.3344 | |
| 56C | 0.3249 | 0.3344 | |
| | 0.3324 | 0.341 | |
| | 0.3323 | 0.3329 | |
| | 0.3253 | 0.3266 | |
| 56D | 0.3253 | 0.3266 | |
| | 0.3323 | 0.3329 | |
| | 0.3323 | 0.3251 | |
| | 0.3256 | 0.3191 | |

Typical Electro-Optical Characteristics Curves(Ta=25)
Typical Curve of Spectral Distribution

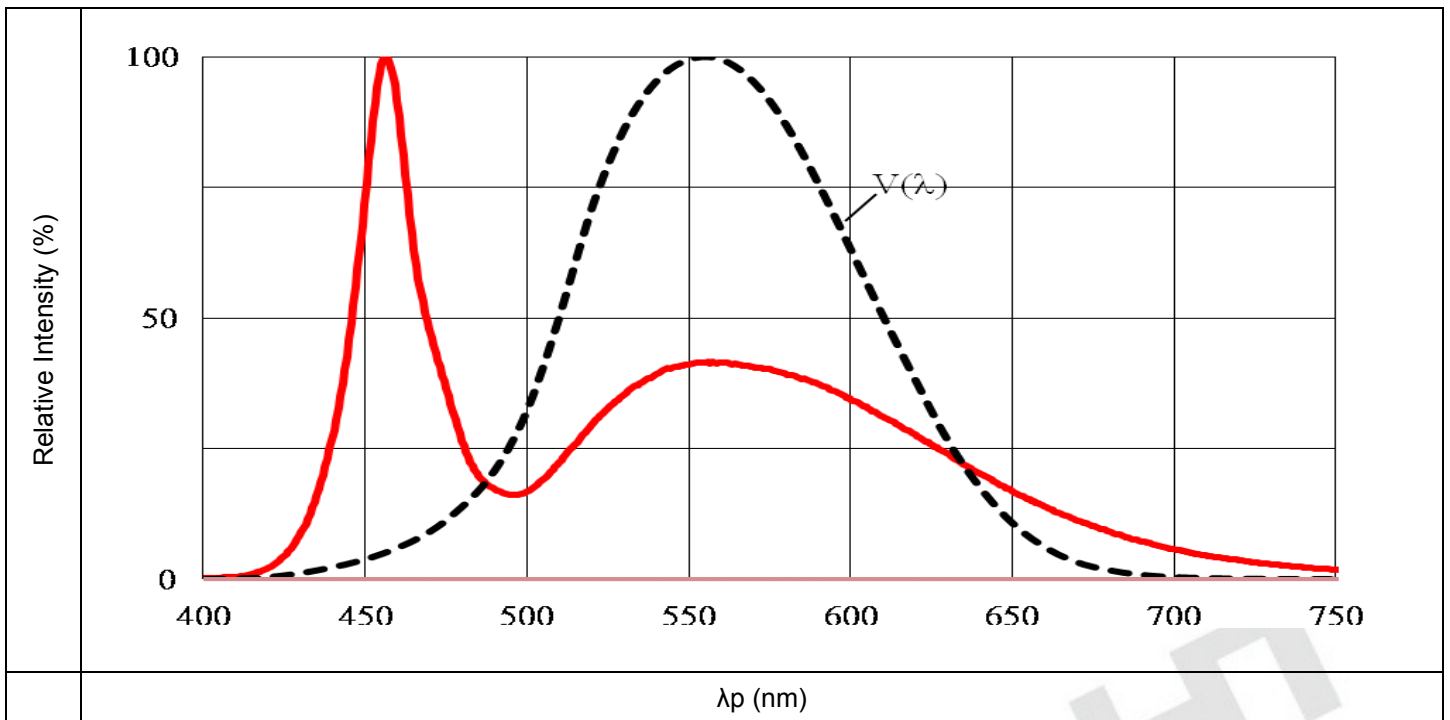

Note: $V(\lambda)$ =Standard eye response curve;

Diagram Characteristics of Radiation

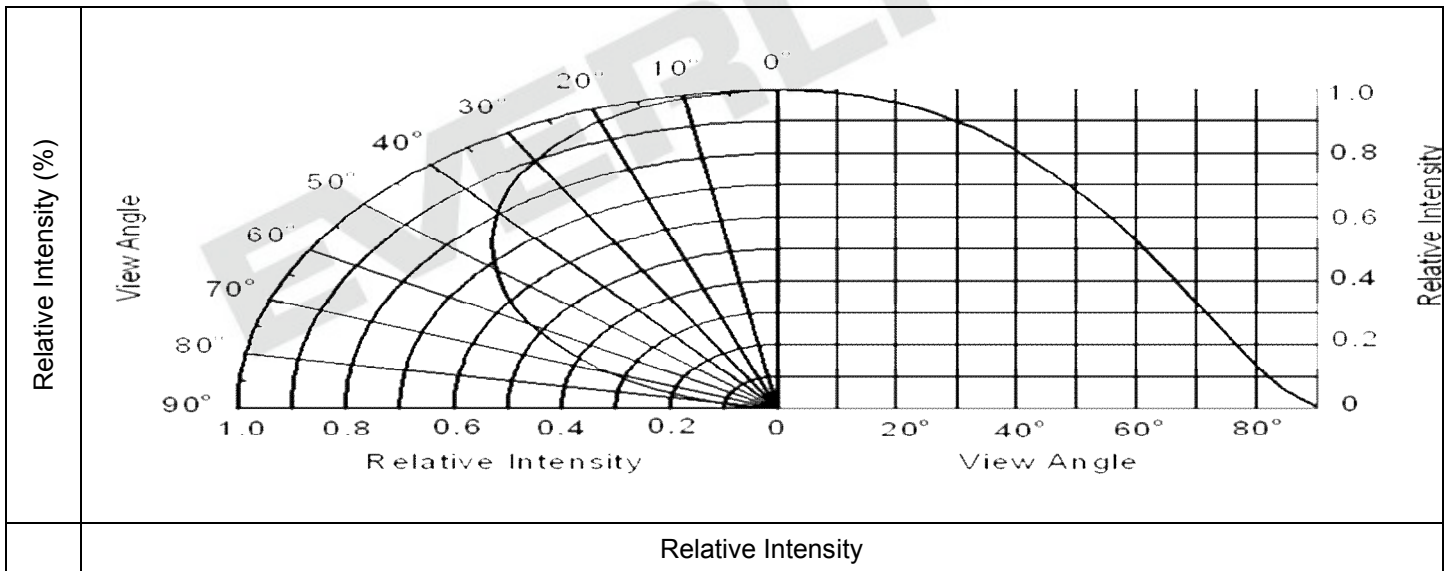

Forward Current vs. Forward Voltage
 (Ta=25 °C)

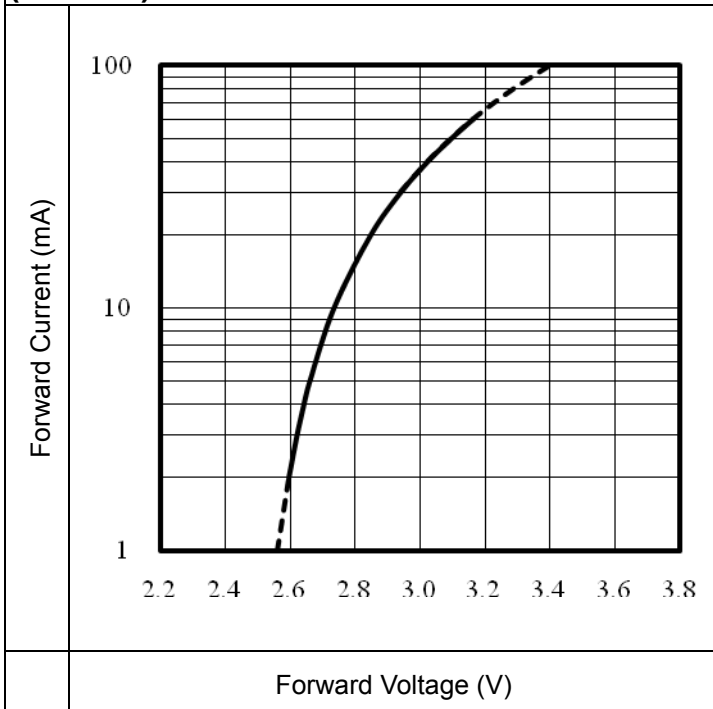

Chromaticity Coordinates vs. Forward Current
 (Ta=25 °C)

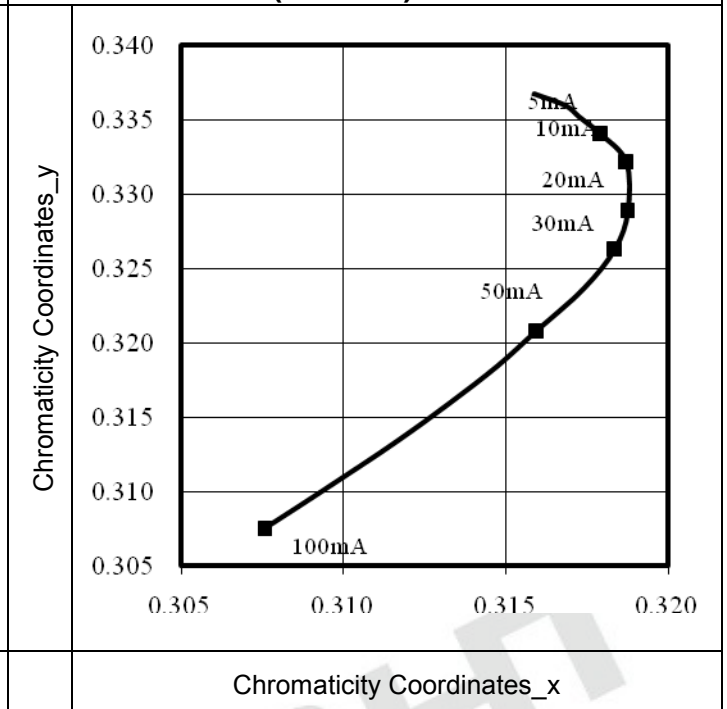

Relative Luminous Intensity vs. Forward Current
 (Ta=25 °C)

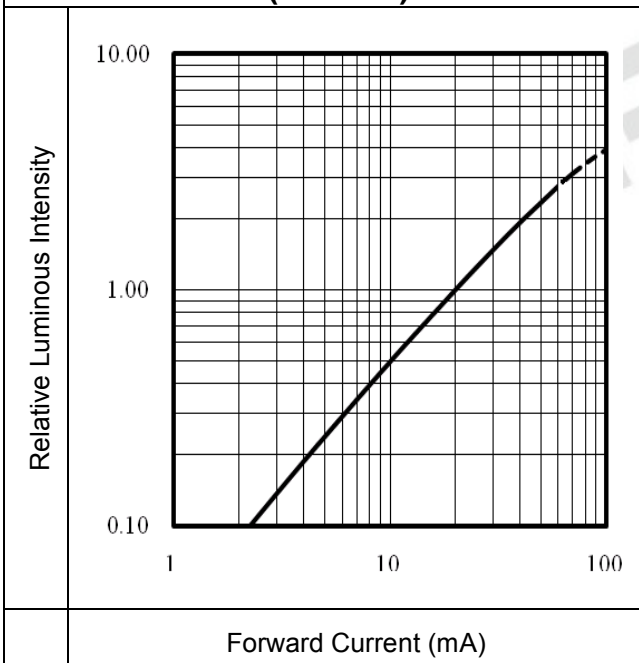

Max. Permissible Forwarded Current

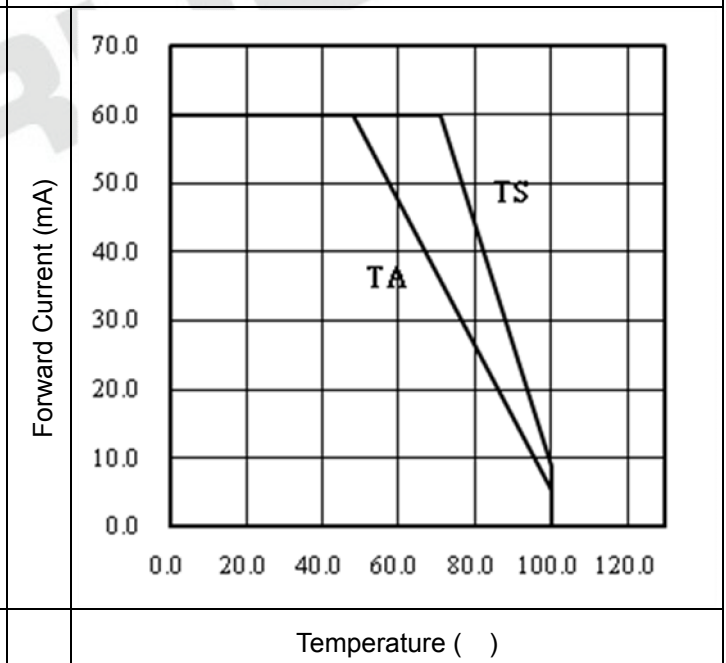

Package Dimension

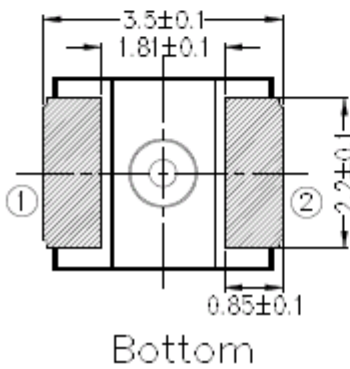
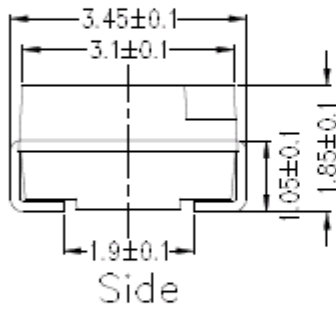
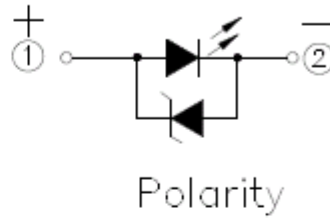
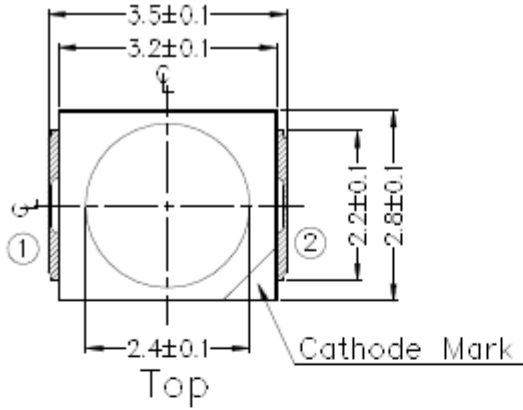

Recommended solder pad

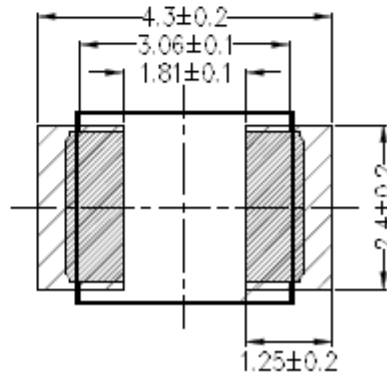

Note: Tolerances unless mentioned ± 0.1 mm. Unit = mm

**Moisture Resistant Packing Materials
 Label Explanation**

- CPN: Customer's Product Number
- P/N: Product Number
- QTY: Packing Quantity
- CAT: Luminous Intensity Rank
- HUE: Chromaticity Coordinates Rank
- REF: Forward Voltage Rank
- LOT No: Lot Number



Reel Dimensions

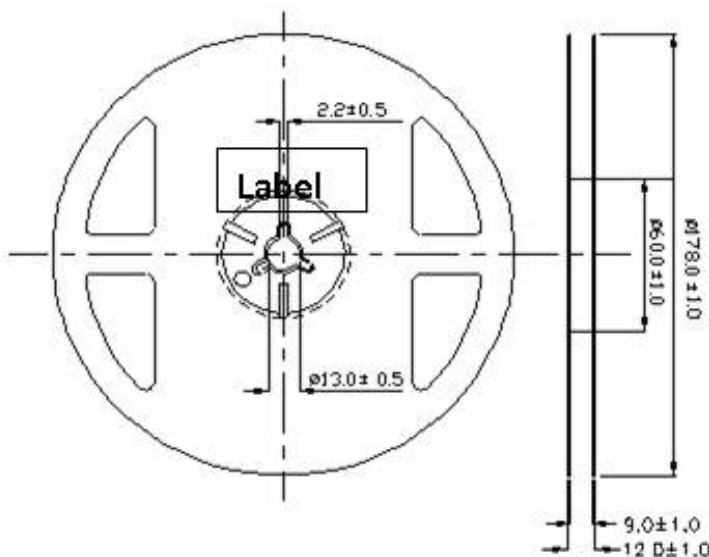

Note: Tolerances unless mentioned ± 0.1 mm. Unit = mm

Carrier Tape Dimensions: Loaded Quantity 2000 pcs Per Reel

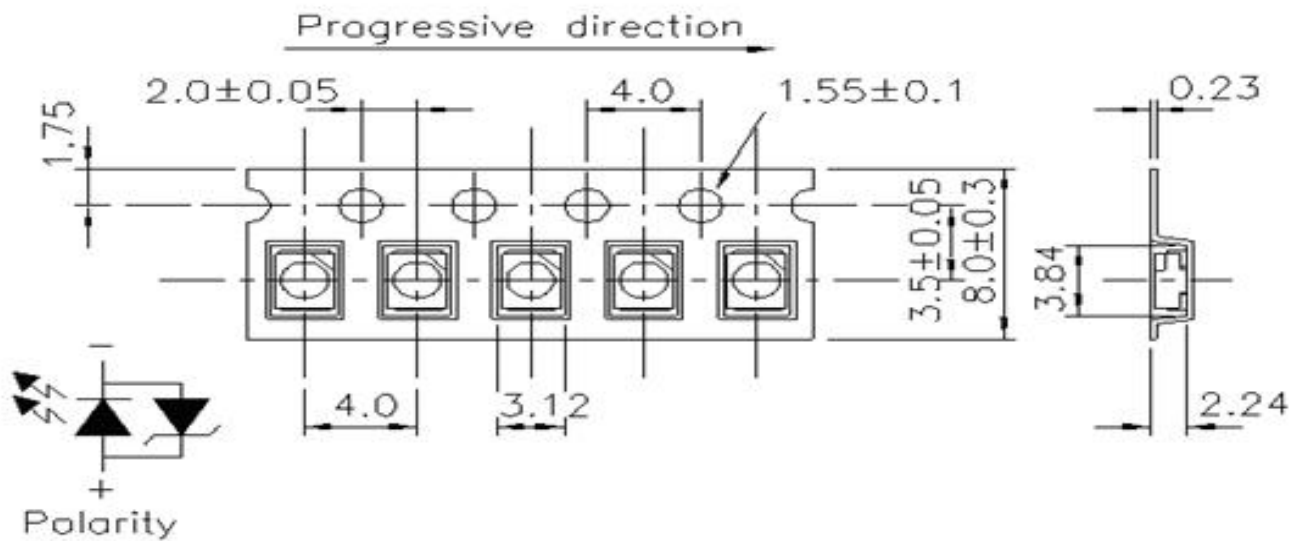

- Note:
1. Tolerances unless mentioned ± 0.1 mm. Unit = mm
 2. Minimum packing amount is 2000 pcs per reel

Moisture Resistant Packing Process

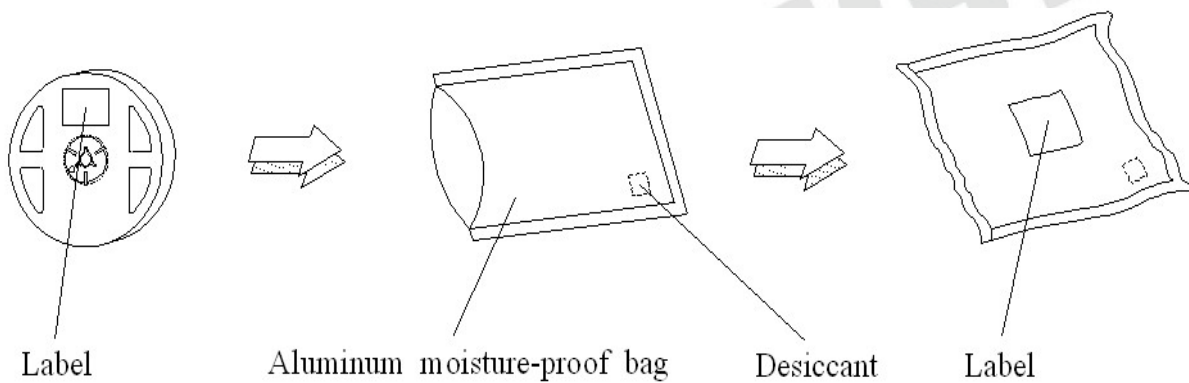

Note: Tolerances unless mentioned ± 0.1 mm. Unit = mm

Precautions for Use

1. Soldering Condition (Reference: IPC/JEDEC J-STD-020D)

a. IR reflow

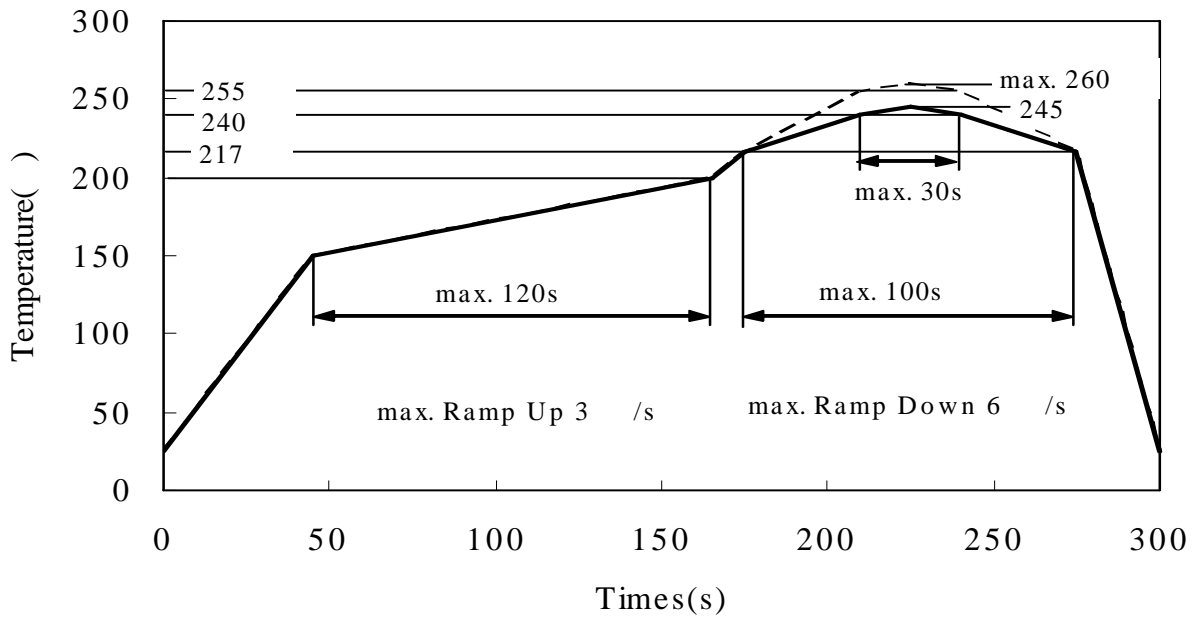

b. Wave soldering reflow

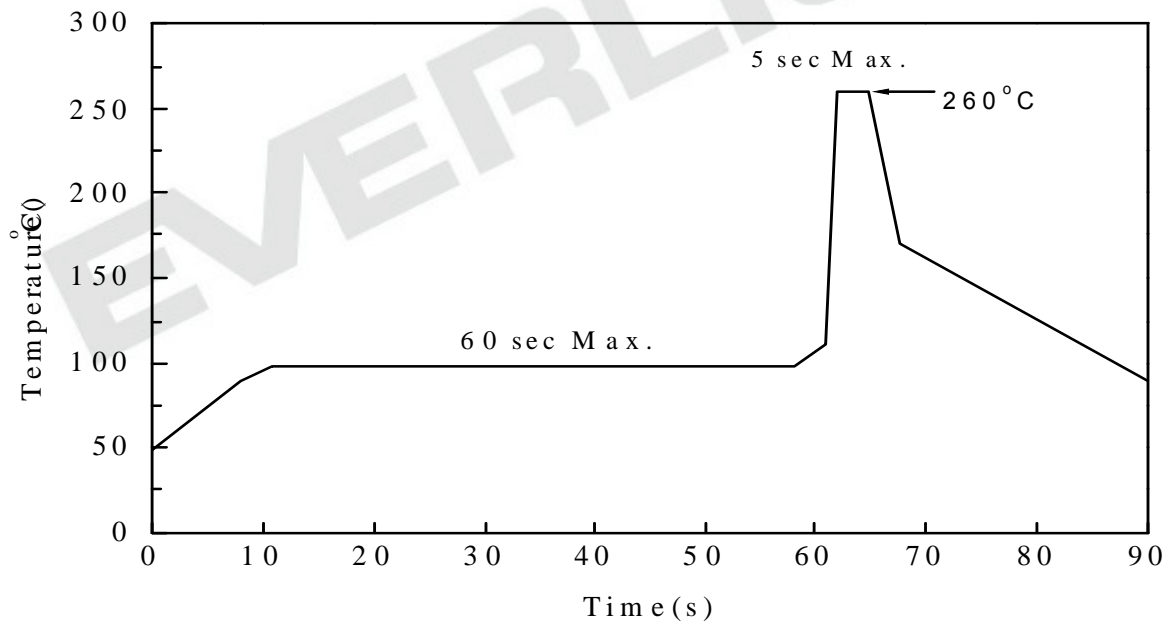

(B) Recommend soldering pad

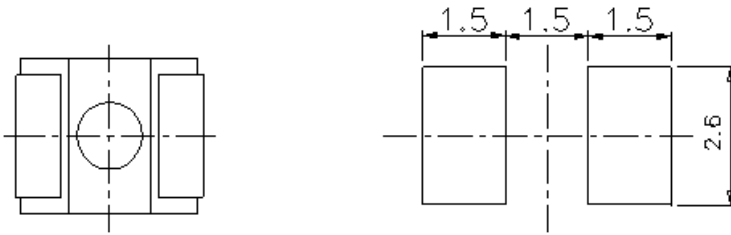

Note: Tolerances unless mentioned ± 0.1 mm. Unit = mm

2. Current limiting

A resistor should be used to limit current spikes that can be caused by voltage fluctuations. Otherwise damage could occur.

3. Storage

- 3.1 Moisture proof bag should only be opened immediately prior to usage.
- 3.2 Environment should be less than 30 °C and 60% RH when moisture proof bag is opened.
- 3.3 After opening the package MSL Conditions stated on page 1 of this spec should not be exceeded.
- 3.4 If the moisture sensitivity card indicates higher than acceptable moisture, the component should be baked at min. 60deg +/-5deg for 24 hours.

4. Iron Soldering

Hand soldering is not recommended for regular production. These guidelines are for rework only. Soldering iron tip should contact each terminal no more than 3 sec at 350 °C, using soldering iron with nominal power less than 25W. Allow min. 2 sec. between soldering intervals.

5. Usage

Do not exceed the values given in this specification.

Application Restrictions

High reliability applications such as military/aerospace, automotive safety/security systems, and medical equipment may require different product. If you have any concerns, please contact Everlight before using this product in your application. This specification guarantees the quality and performance of the product as an individual component. Do not use this product beyond the specification described in this document.

单击下面可查看定价，库存，交付和生命周期等信息

[>>Everlight \(亿光\)](#)