

## ■ NTC熱敏電阻器 NTC THERMISTOR

### ● 概述

這是一種負溫度系數電阻器，其阻值隨環境溫度的升高而降低，這種熱敏電阻是由2種或4種鐵、鎳、鈷、錳或銅的金屬氧化物經過成型并在高溫(1200℃至1500℃)下燒結而制得。

### ● NTC熱敏電阻的主要技術參數

#### \* 零功率電阻值 $R_t$

在規定溫度下，采用引起電阻變化相對於總的測量誤差來說可以忽略不計的測量功率測得電阻值。

#### \* 額定零功率電阻值 $R_{25}$

熱敏電阻器的設計電阻值，通常是指25℃時測得的零功率電阻值并標志在熱敏電阻器上面。

#### \* B值

B值是負溫度系數熱敏電阻器的熱敏指數，它被定義為兩個溫度下零功率電阻值的自然對數之差與這兩個溫度倒數之差的比值：即：

$$B = \ln \frac{R_{T_1}}{R_{T_2}} / \left( \frac{1}{T_1} - \frac{1}{T_2} \right) = \frac{T_1 T_2}{T_2 - T_1} \ln \frac{R_{T_1}}{R_{T_2}}$$

式中： $R_{T_1}$ —溫度為 $T_1$ 時的零功率電阻值

$R_{T_2}$ —溫度為 $T_2$ 時的零功率電阻值

除非特別指出，B值是由25℃(298.15K)和50℃(323.15K)的零功率電阻值計算而得到的，B值在工作溫度範圍內並不是一個嚴格的常數。

#### \* 零功率電阻溫度系數 $\alpha_T$

指在規定溫度下，熱敏電阻器的零功率電阻隨溫度的變化率與它的零功率電阻之比，即：

$$\alpha_T = \frac{1}{R_T} \frac{DR_T}{DT} = - \frac{B}{T^2}$$

式中： $\alpha_T$ —溫度為 $T$ 時的零功率電阻溫度系數

$R_T$ —溫度為 $T$ 時的零功率電阻

$T$ —溫度(以K表示)

$B$ —B值

### OUTLINE

This is a Negative Temperature Coefficient Resistor Whose resistance changes with ambient temperature changes. Thermistor comprises 2 or 4 kinds of metal oxides of iron, nickel, cobalt, manganese and copper, being shaped and Sintered at high temperature(1200℃ to 1500℃)

### Critical Technical Parameters of NTC Thermistor

#### $R_t$ ---Resistance Value at Zero-power

It's a resistance which is got at a fixed temperature on a basis of a testing power which causes resistance to Vary in a range which can be ignored in relation to the total testing error.

#### $R_{25}$ ---Resistance Value at Rated Zero-power

The design resistance of the thermistor usually refers to the resistance value got at Zero-power at 25℃, which is usually indicated on the thermistor.

#### B Value

B value stands for the thermal exponent at a negative temperature coefficient. It's defined as a ratio of the balance between the natural logarithms of resistance values at zero-power to the balance between the reciprocals of the two temperatures. The formula is as below:

$$B = \ln \frac{R_{T_1}}{R_{T_2}} / \left( \frac{1}{T_1} - \frac{1}{T_2} \right) = \frac{T_1 T_2}{T_2 - T_1} \ln \frac{R_{T_1}}{R_{T_2}}$$

In this formula:  $R_{T_1}$  is the resistance at Zero-power when the temperature is  $T_1$

$R_{T_2}$  is the resistance at Zero-power when the temperature is  $T_2$  Unless otherwise specified, B value is got by calculating the Zero-power resistances at 25℃ ( 298.15K ) and 50℃ ( 323.15K ) . It's not a firm constant within the range of working temperature.

#### Resistance-to-Temperature Coefficient at Zero-power

It refers to the ratio of changes of a thermistor. Resistance value at Zero-power when The temperature, to the resistance value at Zero-power The formula is as below:

$$\alpha_T = \frac{1}{R_T} \frac{DR_T}{DT} = - \frac{B}{T^2}$$

In this formula, " $\alpha$ " stands for the resistance-temperature coefficient at Zero-power when the temperature is  $T$ :

$R_T$  stands for the resistance value at Zero-power when the temperature is  $T$

$T$  stands for the temperature(in K)

$B$  stands for B value

\* 最大穩態電流  $I_{max}$

在環境溫度為25℃時允許施加在熱敏電阻器上的最大連續電流。

Max steady state current.

The maximum allowable continuous current passing through thermistor at 25℃.

\* 耗散系數  $\delta$

在規定的環境溫度下，熱敏電阻器耗散功率與其相應溫度變化之比，： $\delta = P / T$ ，在工作溫度範圍內， $\delta$  隨環境溫度變化而有所變化。

Dissipation Coefficient  $\delta$

It's the ratio of the changes with a thermistor dissipation power, in a pre-set ambient temperature, to the changes with the temperature. The formula is as below:  $\delta = \Delta P / \Delta T$   $\delta$  changes in response when the ambient temperature changes, within the ranges of the working temperature.

\* 熱時間常數  $\tau$

在零功率條件下，當溫度發生突變時，熱敏電阻體溫度變化了始末溫度差的63.2%所需的時間。 $\tau$  與熱敏電阻器的熱容量  $C$  成正比，與其耗散系數  $\delta$  成反比，即： $\tau = C / \delta$

Thermal Time Constant

At Zero-power and when a mutation occurs with the temperature, the time "t", which is spent for finishing 63.2% of the gap between the beginning temperature and the ending temperature in the thermistor, is directly proportional to "c", the heat capacity of the thermistor, and is inversely proportional to  $\delta$ , the dissipation constant. That is " $\tau = C / \delta$ ".

## ■ 應用範圍

適用於轉換電源、開關電源、USB 電源、各類電加熱器、電子節能燈、電子鎮流器、各種電子裝置電源電路的保護以及彩色顯示管、白熾燈及其它照明燈具的燈絲保護。

## APPLICATIONS

Conversion power supply, switch power, UPS power, Kinds of electric heater, electronic energy-saving lamps, electronic ballast etc all kinds of power circuit protection of electronic equipments, filament protection of CRT, bulb and other lighting lamps.

■ 抑制浪涌電流負溫度系數(NTC)熱敏電阻器  
Surge-Arrestor NTC Thermistor

● 特性

- \* 體積小、功率大、抑制浪涌電流能力強
- \* 反應速度快
- \* B值大，殘余電阻小、壽命長、可靠性高、系列安全，工作圍寬。

FEATURES

Small in size, high-powered, and very capable of bringing down the surge current;  
Quick in reaction;  
High in B value and low in residual current;  
Long service life and high reliability;  
High coefficient of safety and wide range of application.

● 訂貨方式 HOW TO ORDER



● 外型尺寸 DIMENSIONS (mm)

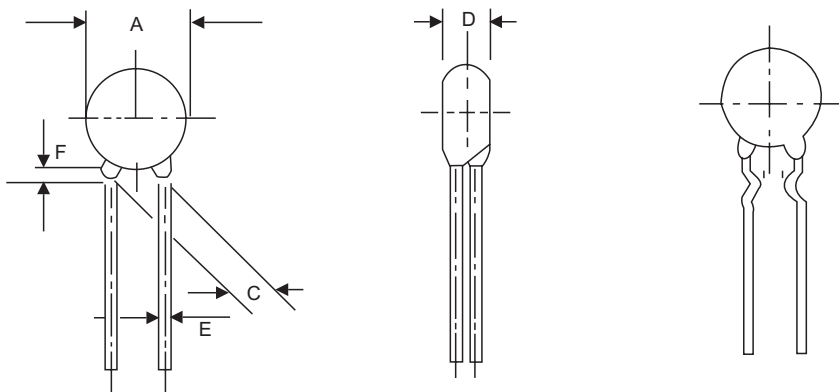

尺寸(mm)

規格 Type	A <sub>MAX</sub>	C ± 1	D <sub>MAX</sub>	E ± 0.05	F <sub>MAX</sub>
D-20	22	7.5/10	7	1.0	4
D-15	16.5	7.5	6	1.0	4
D-13	14.5	7.5	6	0.8	4
D-11	12.5	7.5	5	0.8	4
D-9	10.5	7.5	5	0.8	4
D-7	8.5	5.0	5	0.5	4

- \* 注: 1、對於芯片直徑 ≤ φ13，工作電流 ≤ 2A的規格，E可取0.6。
- 2、G、H為引綫打彎所規定尺寸。

- \* Remarks: 1、"E" value may be 0.6 for resistors for which the chip's diameter is ≤ 13 and the working current is ≤ 2A.
- 2、"G" column and "H" column stand for bend dimensions of the lead.

**• 電性能 SPECIFICATIONS & PROPERTIES**

型號 Model	R25°C ±20%(Ω)	最大穩態 電流(A) Max Steady- current(A)	最大電流時近 似電阻值(Ω) Approx R of Max. Cur.(Ω)	耗散系數 Power Dissipation coef- ficient(mW/°C)	時間常數 Time Constant (s)
NTC 5D-7	5	2	0.241	10	30
NTC 8D-7	8	1.5	0.436	9	28
NTC 10D-7	10	1	0.572	9	27
NTC 16D-7	16	0.7	0.897	9	27
NTC 22D-7	22	0.6	1.083	8	27
NTC 2.5D-9	2.5	4	0.128	11	35
NTC 3D-9	3	4	0.133	11	35
NTC 5D-9	5	3	0.236	11	35
NTC 8D-9	8	2	0.382	11	34
NTC 10D-9	10	2	0.476	11	34
NTC 16D-9	16	1	0.688	11	32
NTC 22D-9	22	1	0.899	11	30
NTC 25D-9	25	1	0.914	12	30
NTC 35D-9	35	1	1.103	12	30
NTC 50D-9	50	1	1.265	11	30
NTC 60D-9	60	1	1.521	11	30
NTC 80D-9	80	0.8	2.108	11	30
NTC 100D-9	100	0.8	2.576	11	30
NTC 120D-9	120	0.8	3.115	11	30
NTC 200D-9	200	0.5	5.900	10	32
NTC 300D-9	300	0.5	9.150	10	32
NTC 2.5D-11	2.5	5	0.120	13	46
NTC 3D-11	3	5	0.126	13	45
NTC 5D-11	5	4	0.288	13	45
NTC 8D-11	8	3	0.301	13	45
NTC 10D-11	10	3	0.395	14	47
NTC 16D-11	16	2	0.488	14	50
NTC 2.5D-13	2.5	6	0.099	13	60
NTC 3D-13	3	6	0.112	14	60
NTC 5D-13	5	5	0.136	15	68
NTC 8D-13	8	4	0.256	15	65
NTC 10D-13	10	4	0.271	15	65
NTC 16D-13	16	3	0.368	16	60
NTC 3D-15	3	7	0.094	18	76
NTC 4D-15	4	6	0.128	20	76
NTC 5D-15	5	6	0.132	20	76
NTC 8D-15	8	5	0.196	20	80
NTC 10D-15	10	5	0.255	20	85
NTC 16D-15	16	4	0.307	19	77
NTC 3D-15	3	8	0.079	24	100
NTC 5D-20	5	7	0.106	23	87
NTC 8D-20	8	6	0.157	23	105
NTC 10D-20	10	6	0.194	23	118

单击下面可查看定价，库存，交付和生命周期等信息

[>>FH\(风华高科\)](#)