

PRODUCT SPECIFICATION

6223E-UUD

**Wi-Fi Single-band 1x1 + Bluetooth 2.1 + EDR /
3.0/3.0+HS/4.2 Combo Module**

Version:v1.9



6223E-UUD Module Datasheet

Ordering Information	Part NO.	Description
	FG6223EUUD-W1	RTL8723DU, b/g/n, Wi-Fi+BLE4.2, 1T1R, 12.2X13mm, USB+PCM Single antenna, PCB version V1.0
	FG6223EUUD-W2	RTL8723DU, b/g/n, Wi-Fi+BLE4.2, 1T1R, 12.2X13mm, USB+PCM, Dual Antenna, PCB version V1.0
	FG6223EUUD-W3	RTL8723DU, b/g/n, Wi-Fi+BLE4.2, 1T1R, 12.2X13mm, USB+PCM Single antenna, PCB version V1.0 (with shield cover)

Customer: _____

Customer P/N: _____

Signature: _____

Date: _____

Office: 14th floor, Block B, phoenix zhigu, Xixiang Street, Baoan District, Shenzhen

Factory: NO.8, Litong RD., Liuyang Economic & Technical Development Zone, Changsha, CHINA

TEL:+86-755-2955-8186

Website:www.fn-link.com

CONTENTS

1. General Description	5
1.1 Introduction	5
1.2 Description	5
2. Features	6
3. Block Diagram	6
4. General Specification	7
4.1 WI-FI Specification	7
4.2 Bluetooth Specification	9
5. ID setting information	9
6. Pin Definition	10
6.1 Pin Outline	10
6.2 Pin Definition details	11
7. Electrical Specifications	12
7.1 Power Supply DC Characteristics	12
7.2 Power Consumption	12
7.3 Interface Circuit time series	12
7.3.1 module power-on&off time sequence	12
7.3.2 Timing information	14
8. Size reference	16
8.1 Module Picture	16
8.2 Physical Dimensions	17
8.3 Layout Recommendation	18
9. The Key Material List	18
10. Reference Design	19
11. Recommended Reflow Profile	20
12. RoHS compliance	20
13. Package	21
13.1 Reel	21
13.2 Carrier Tape Detail	21
13.3 Packaging Detail	22
14. Moisture sensitivity	23

Revision History

Version	Date	Contents of Revision Change	Draft	Checked	Approved
V1.0	2018/10/19	New version	Lzm	Lzm	Jacky
V1.1	2018/12/18	Modify the telephone number	Lzm	Lzm	Lxy
V1.2	2018/12/25	Modify the office and TEL	Lzm	Lzm	Lxy
V1.3	2019/02/27	Remove PCM interfaces,change to use USB interface	Whh	Whh	Lxy
V1.4	2019/09/17	Update dimension information	Lxy	Lxy	Szs
V1.5	2019/12/09	Change back to add PCM	Lxy	Lxy	Szs
V1.6	2020/02/14	Add description for pin9	Lxy	Lxy	Szs
V1.7	2021/08/31	Update package quantity to 1500	Lxy	Lxy	Szs
V1.8	2022/02/07	1.Update the specification format 2.Up and down electricity time series supplement 3.The RF index was changed to ± 2 dbm 4.W1&W2&W3 merge into a module datasheet 5.Update power supply DC Characteristics and power consumption	FC	LXY	QJP
V1.9	2022/05/17	Update packaging information	FC	LXY	QJP

1. General Description

1.1 Introduction

6223E-UUD is a small size and low profile of Wi-Fi + BT Combo module, board size is 12.2mm*13mm. It can be easily manufactured on SMT process and highly suitable for tablet PC, ultra book, mobile device and consumer products. It provides USB interface for Wi-Fi and Bluetooth. The module provides simple legacy and 20MHz/40MHz co-existence mechanisms to ensure backward and network compatibility and Bluetooth can support BT2.1+EDR/BT3.0 and BT4.2.

6223E-UUD uses highly integrated Wi-Fi/BT single chip based on advanced COMS process. 6223E-UUD integrates whole Wi-Fi/BT function blocks into a chip, such as USB, MAC, BB, AFE, RFE, PA, EEPROM and LDO/SWR, except fewer passive components remained on PCB.

This compact module is a total solution for a combination of Wi-Fi + BT technologies. The module is specifically developed for Smart phones and Portable devices.

1.2 Description

Model Name	6223E-UUD
Product Description	Support Wi-Fi/Bluetooth functionalities
Dimension	L x W x H: 12.2 x 13 x1.6 (typical) mm
Wi-Fi Interface	Support USB2.0
BT Interface	Support USB2.0
OS supported	Android /Linux/ Win CE /iOS /XP/WIN7/WIN10
Operating temperature	0°C to 70°C
Storage temperature	-55°C to 85°C

2. Features

General Features

- Operate at ISM frequency bands (2.4GHz)
- IEEE standards support: IEEE 802.11b, IEEE 802.11g, IEEE 802.11n, IEEE 802.11d, IEEE 802.11e, IEEE 802.11h, IEEE 802.11i
- Enterprise level security which can apply WPA/WPA2 certification for Wi-Fi
- Wi-Fi 1 transmitter and 1 receiver allow data rates supporting up to 150 Mbps downstream and 150 Mbps upstream PHY rates

WLAN Interface

- USB for Wi-Fi and Bluetooth

Bluetooth Features

- Fully Qualified for Bluetooth 2.1+EDR specification including both 2Mbps and 3Mbps modulation mode
- Fully qualified for Bluetooth 3.0
- Fully qualified for Bluetooth 4.2 Dual mode
- Full - speed Bluetooth operation with Piconet and Scatternet support

3. Block Diagram

single Antenna:

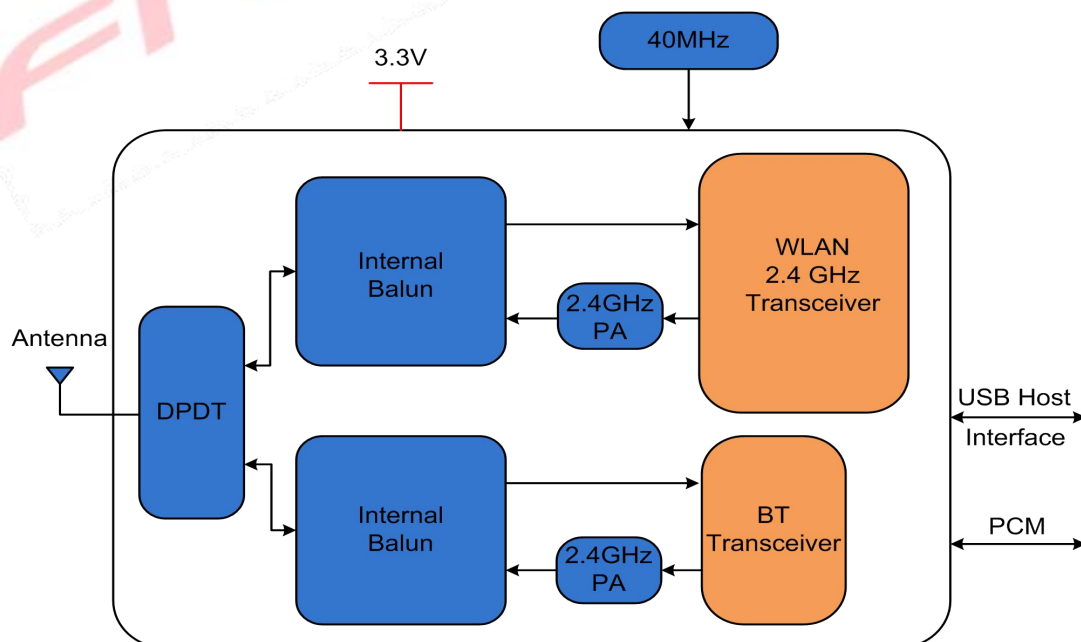

Dual Antenna:

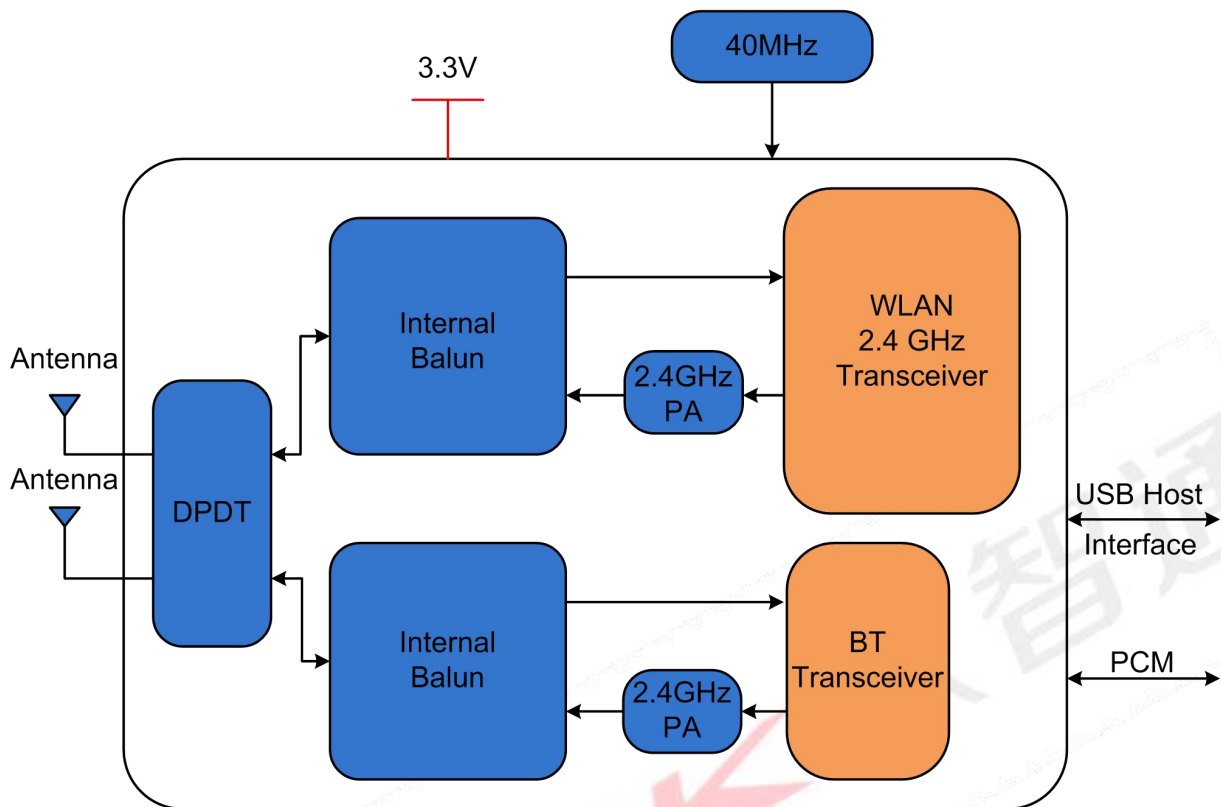

4. General Specification

4.1 WI-FI Specification

Feature	Description	
WLAN Standard	IEEE 802.11 b/g/n Wi-Fi compliant	
Frequency Range	2.400 GHz ~ 2.4835 GHz (2.4 GHz ISM Band)	
Number of Channels	2.4GHz: Ch1 ~ Ch14	
Test Items	Typical Value	EVM
Output Power	802.11b /11Mbps : 16dBm ± 2 dB	EVM ≤ -10dB
	802.11g /54Mbps : 14dBm ± 2 dB	EVM ≤ -25dB
	802.11n /MCS7 : 13dBm ± 2 dB	EVM ≤ -28dB
Spectrum Mask	Meet with IEEE standard	
Freq. Tolerance	±20ppm	

Test Items	TYP Test Value	Standard Value
Receive Sensitivity (11b,20MHz) @8% PER	- 1Mbps PER @ -91 dBm	≤-83
	- 2Mbps PER @ -89 dBm	≤-80
	- 5.5Mbps PER @ -87 dBm	≤-79
	- 11Mbps PER @ -85 dBm	≤-76
Receive Sensitivity (11g,20MHz) @10% PER	- 6Mbps PER @ -87 dBm	≤-85
	- 9Mbps PER @ -86 dBm	≤-84
	- 12Mbps PER @ -84 dBm	≤-82
	- 18Mbps PER @ -82 dBm	≤-80
	- 24Mbps PER @ -79 dBm	≤-77
	- 36Mbps PER @ -75 dBm	≤-73
	- 48Mbps PER @ -71 dBm	≤-69
	- 54Mbps PER @ -70 dBm	≤-68
Receive Sensitivity (11n,20MHz) @10% PER	- MCS=0 PER @ -87 dBm	≤-85
	- MCS=1 PER @ -84 dBm	≤-82
	- MCS=2 PER @ -82 dBm	≤-80
	- MCS=3 PER @ -79 dBm	≤-77
	- MCS=4 PER @ -75 dBm	≤-73
	- MCS=5 PER @ -71 dBm	≤-69
	- MCS=6 PER @ -70 dBm	≤-68
	- MCS=7 PER @ -69 dBm	≤-67
Receive Sensitivity (11n,40MHz) @10% PER	- MCS=0, PER @ -84 dBm	≤-82
	- MCS=1, PER @ -81 dBm	≤-79
	- MCS=2, PER @ -79 dBm	≤-77
	- MCS=3, PER @ -76 dBm	≤-74
	- MCS=4, PER @ -72 dBm	≤-70
	- MCS=5, PER @ -68 dBm	≤-66
	- MCS=6, PER @ -67 dBm	≤-65
	- MCS=7, PER @ -66 dBm	≤-64
Maximum Input Level	802.11b : ≥-8 dBm	
	802.11g/n : ≥-20 dBm	

4.2 Bluetooth Specification

Feature	Description		
General Specification			
Bluetooth Standard	Bluetooth V2.1+EDR/BT v3.0/BT v3.0+HS/BT v4.2		
Host Interface	USB		
Frequency Band	2402 MHz ~ 2480 MHz		
Number of Channels	79 channels		
Modulation	GFSK, $\pi/4$ -DQPSK, 8-DPSK		
RF Specification			
	Min(dBm)	Typical(dBm)	Max(dBm)
Output Power (Class 1)	2	5	8
Sensitivity @ BER=0.1% for GFSK (1Mbps)		-89	
Sensitivity @ BER=0.01% for $\pi/4$ -DQPSK (2Mbps)		-86	
Sensitivity @ BER=0.01% for 8DPSK (3Mbps)		-83	

5. ID setting information

WI-FI

Vendor ID	0BDAh
Product ID	D723h

6. Pin Definition

6.1 Pin Outline

< TOP VIEW >

single Antenna:

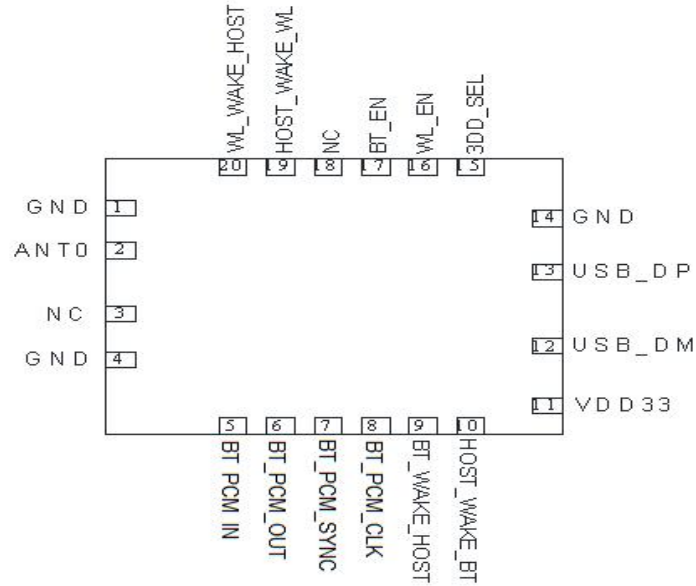

Dual Antenna:

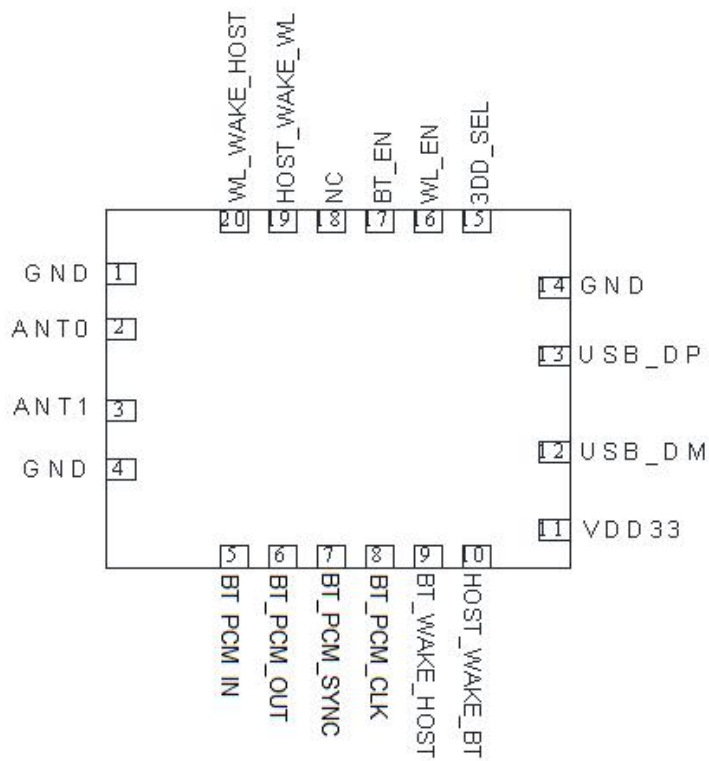

6.2 Pin Definition details

NO.	Name	Type	Description	Voltage
1	GND	—	Ground connections	
2	ANT 0	I/O	RF I/O	
3	ANT 1/NC	—	Dual Antenna: Wi-Fi RF I/O single Antenna: Not connecting (NC)	
4	GND	—	Ground connections	
5	BT_PCM_IN	I/O	GPIO0,BT_PCM_IN. If not used please NC, Don' t connected to ground.	
6	BT_PCM_OUT	I/O	GPIO1,BT_PCM_OUT. If not used please NC, Don' t connected to ground.	
7	BT_PCM_SYNC	I/O	GPIO2,BT_PCM_SYNC. If not used please NC, Don' t connected to ground.	
8	BT_PCM_CLK	I/O	GPIO3,BT_PCM_CLK. If not used please NC, Don't connected to ground.	
9	BT_WAKE_HOST	O	Bluetooth device wake up host IC pin GPIO14, pull high boot to test mode,pull low boot to normal mode.be carefull to using this pin.	3.3V
10	HOST_WAKE_BT	I	Host wake up Bluetooth device ,IC pin GPIO13	3.3V
11	VDD33	—	Main power voltage source input 3.3V	3.3V
12	USB_DM	I/O	USB2.0 differential pair for WLAN And Bluetooth	
13	USB_DP	I/O	USB2.0 differential pair for WLAN And Bluetooth	
14	GND	—	Ground connections	
15	3DD_SEL	—	Not connecting ,Don' t connected to ground IC pin GPIO6	3.3V
16	WL_EN	I	WLAN disable Default pull high, external pull low disable WL This pin function is not supported	3.3V
17	BT_EN	I	Bluetooth disable Default pull high, external pull low disable BT This pin function is not supported	3.3V
18	NC	I	Not connecting (Don't connected to ground)	
19	HOST_WAKE_WL	I	Host wake up WLAN device IC pin BT_GPIO14	3.3V
20	WL_WAKE_HOST	O	WLAN device wake up host IC pin GPIO8	3.3V

P:POWER I:INPUT O:OUTPUT

7. Electrical Specifications

7.1 Power Supply DC Characteristics

	MIN	TYP	MAX	Unit
Operating Temperature	0	25	70	deg.C
VCC33	3.0	3.3	3.6	V
VDDIO	1.62	1.8 or 3.3	3.6	V

7.2 Power Consumption

Power Consumption	VCC33 = 3.3V(Unit:mA)	
	Wi-Fi on Mode	68
	TX (2.4G HT40)	110
	RX (2.4G HT40)	107
	BT on	8.5

7.3 Interface Circuit time series

7.3.1 module power-on&off time sequence

	Min	Typical	Max	Unit
T33 power on ramp	0.2	0.5	2.5	ms
T33 power off ramp	0.2	5	10	ms

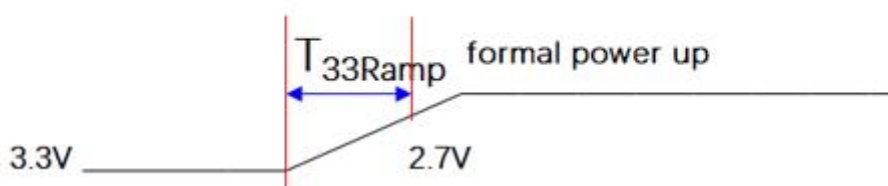

1.上下电时序请满足表格要求；

The power up ramp and power down ramp must meet the following table.

2.上下电过程如有较长时间中间电压停留都会有几率导致 efuse 被窜写；

If climbing process for a long time during power-on and power-off , It may cause efuse to be overwritten.

3.建议主芯片上电完成后，再给模组上电；

it is recommended to power on the module after platform side.

4.如有下图所示异常上下电时序，务必做相应调整符合时序规格；

If power on/off timing as below shown, must modify to meet the timing specification.

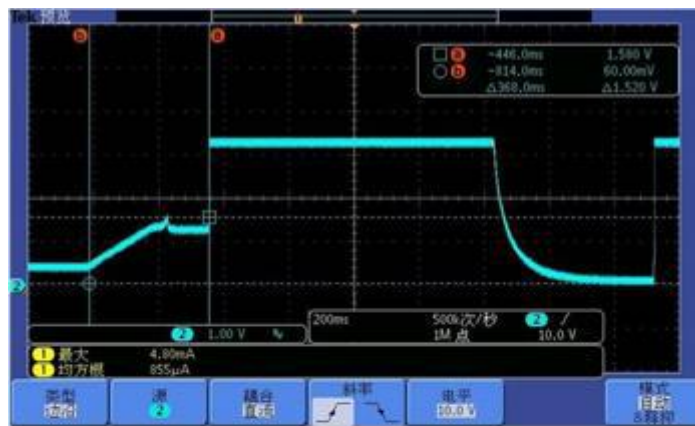

异常上电时序

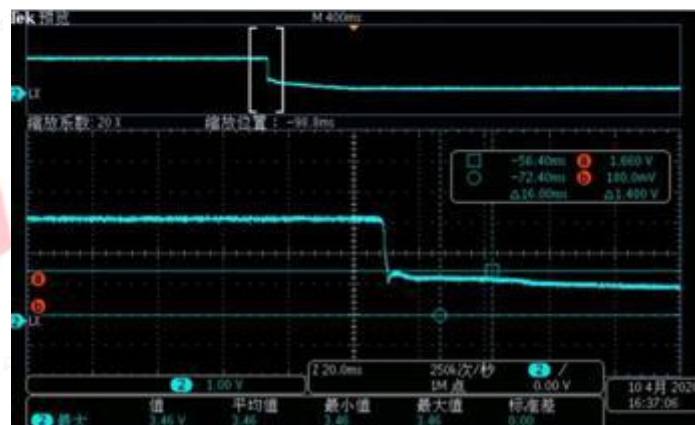

异常下电时序

7.3.2 Timing information

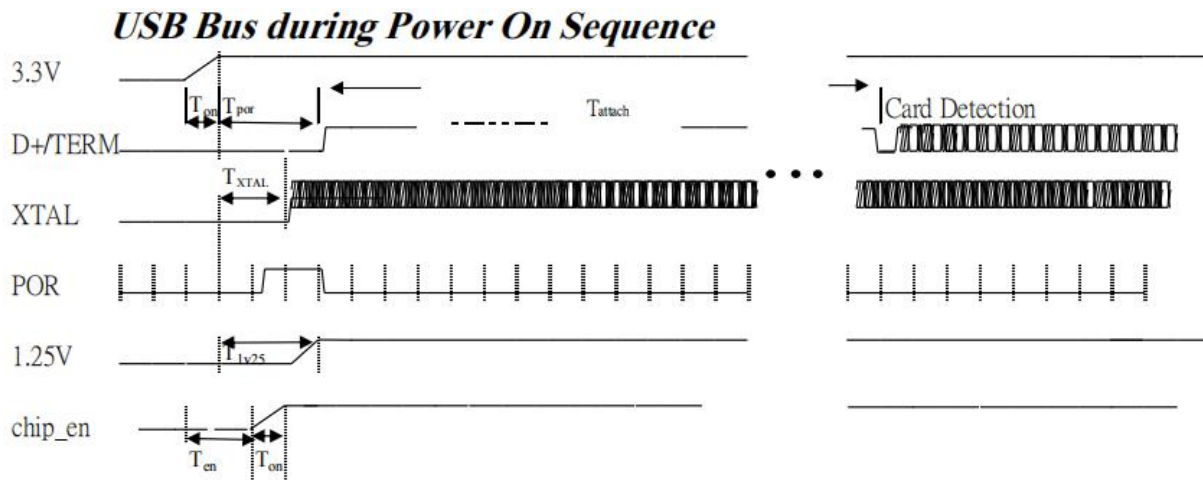

RTL8723DU USB Bus Power On Sequence

- T_{on}**: The main power ramp up duration
- T_{por}**: The power on reset releases and power management unit executes power on tasks
- T_{attach}**: USB attach state
- T_{k-state}**: the duration from resistor attached to USB host starting card detection procedure

The power on flow description:

After main 3.3V ramp up, the internal power on reset is released by power ready detection circuit and the power management unit will be enabled. The power management unit enables the internal regulator and clock circuits. The power management unit also enables the USB circuits. USB analog circuits attach resistors to indicate the insertion of the USB device

The typical timing range

	Unit	Min	Typical	Max
T_{on}	ms	0.2	1.5	5
T_{por}	ms	--	2	10
T_{xtal}	ms	--	1.5	8
T_{attach}	ms	100	250	--
T_{lv25}	ms	-	2	5
T_{en}	ms	0	0	5

PCM Interface Characteristics

The RTL8723D supports a PCM digital audio interface that is used for transmitting digital audio/voice data to/from the Audio Codec. Features are supported as below:

- Supports Master and Slave mode
- Programmable long/short Frame Sync
- Supports 8-bit/16-bit linear PCM formats
- PCM Master Clock Output: 64, 128, 256, or 512kHz
- Supports SCO/ESCO link

PCM Format

FrameSync is the synchronizing function used to control the transfer of DAC_Data and ADC_Data. A Long FrameSync indicates the start of ADC_Data at the rising edge of FrameSync (Figure 7. Long FrameSync), and a Short FrameSync indicates the start of ADC_Data at the falling edge of FrameSync (Figure 8. Short FrameSync).

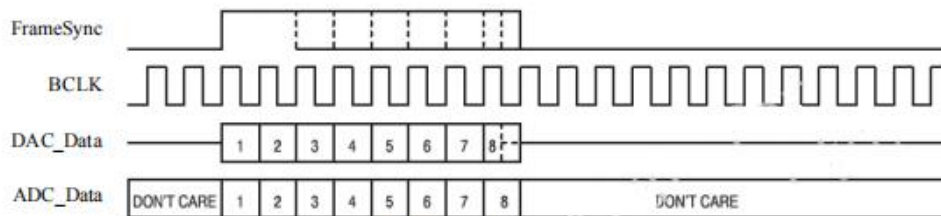

Figure 7. Long FrameSync

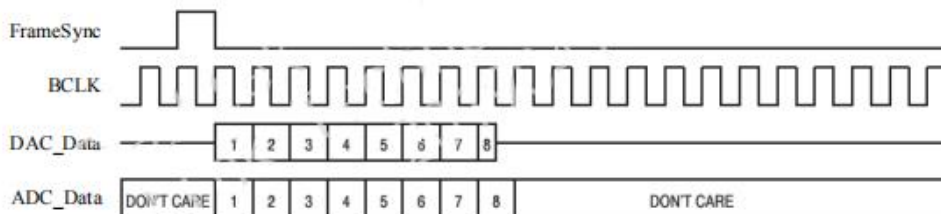

Figure 8. Short FrameSync

8. Size reference

8.1 Module Picture

L x W : 13 x 12.2 (+0.3/-0.1) mm

FG6223EUUD-W1:

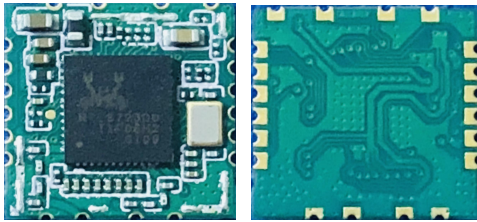

FG6223EUUD-W2:

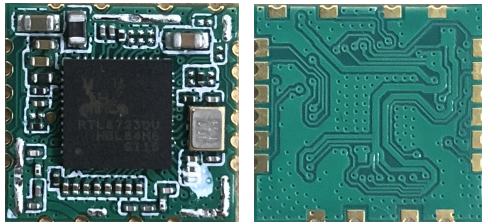

FG6223EUUD-W3:

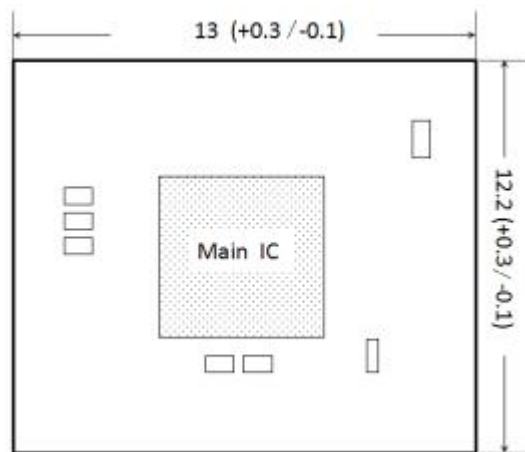
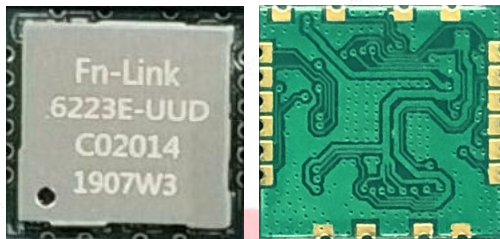

FG6223EUUD-W1 H: 1.6 (±0.2) mm

FG6223EUUD-W2 H: 1.6 (±0.2) mm

FG6223EUUD-W3 H: 1.9 (±0.2) mm

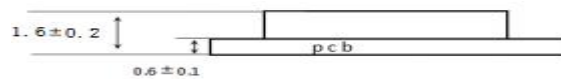

Weight

FG6223EUUD-W1: 0.37g

FG6223EUUD-W2: 0.40g

FG6223EUUD-W3: 0.54g

8.2 Physical Dimensions

<TOP View>

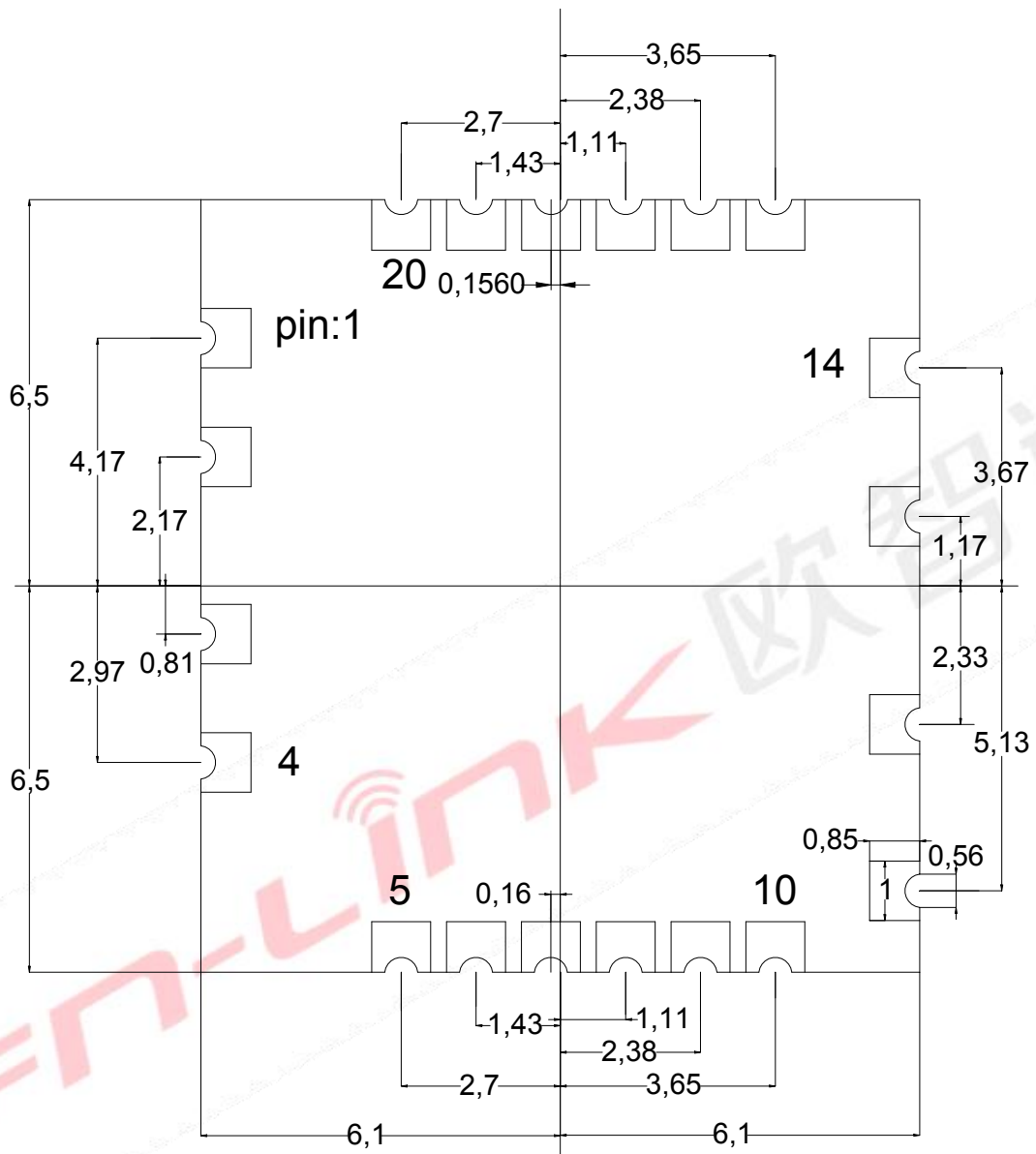

8.3 Layout Recommendation

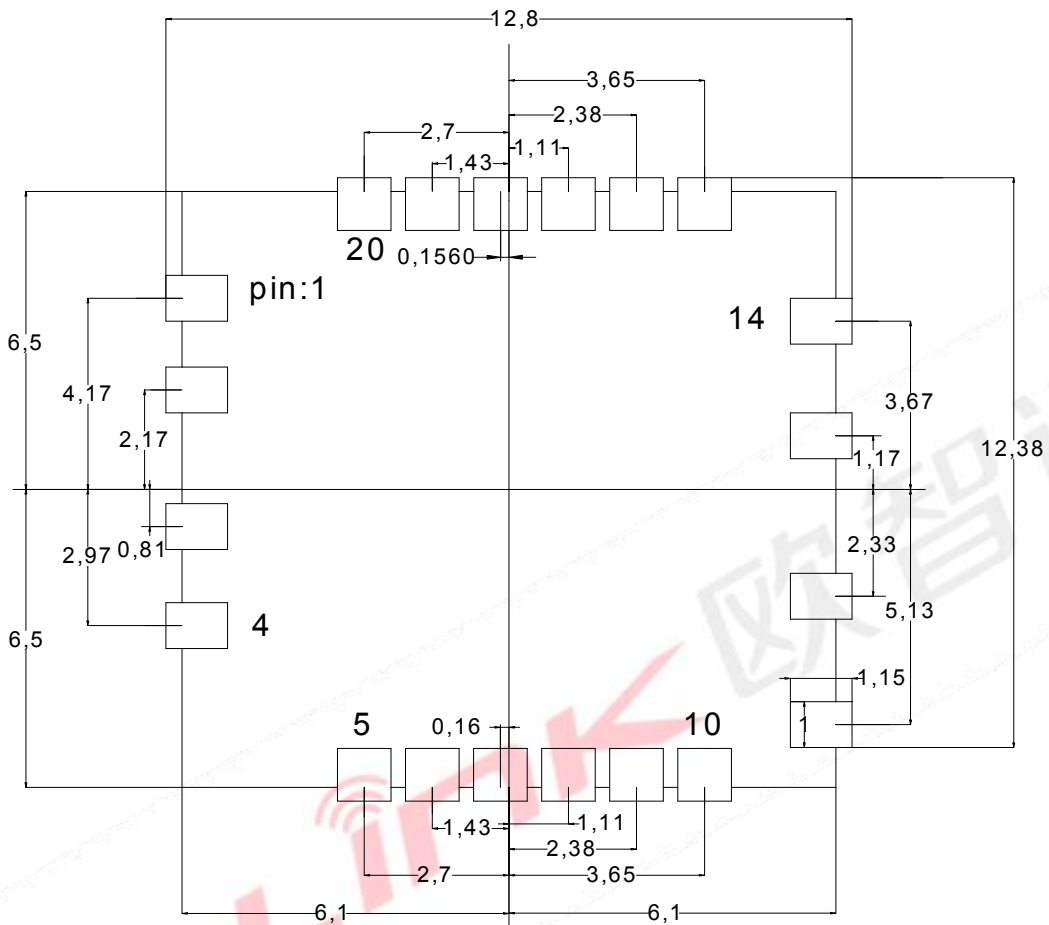

9. The Key Material List

Item	Part Name	Description	Manufacturer
1	PCB	6223E-UUD-V1.0	XY-PCB, GDKX, Sunlord, SLPCB
2	Crystal	2520 40MHZ 15PF,10ppm	ECEC, Hosonic, TKD, JWT
3	Chipset	RTL8723DU-CG	Realtek
4	Shielding	6223E-UUD Shielding	信太, 精力通

10. Reference Design

Single antenna:

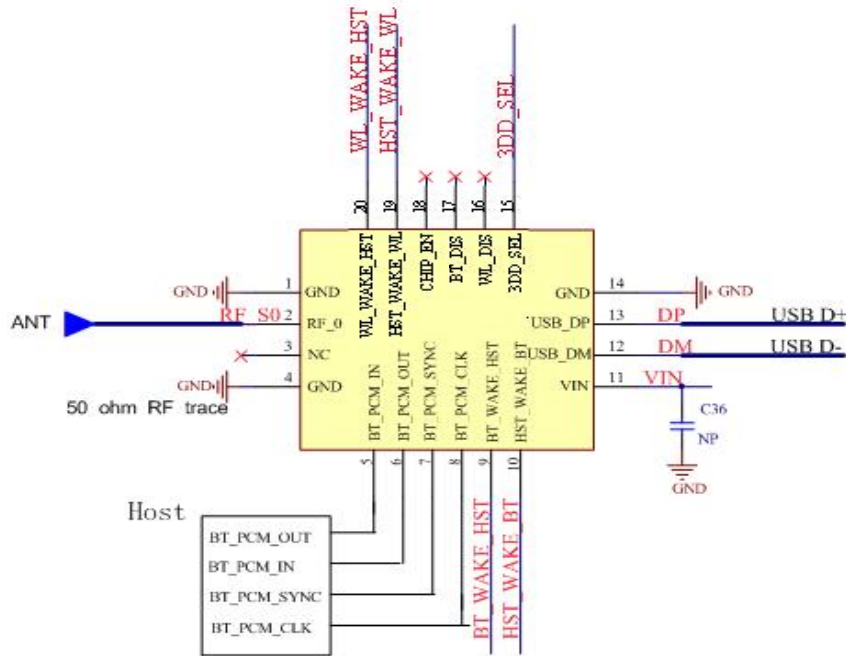

Dual Antenna:

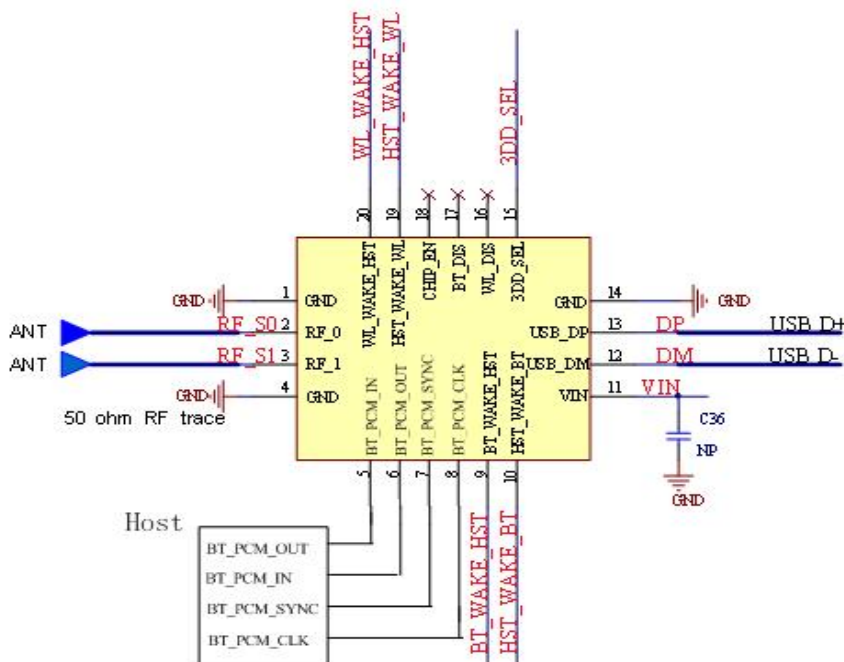

11. Recommended Reflow Profile

Referred to IPC/JEDEC standard.

Peak Temperature : <260°C

Number of Times : ≤2 times

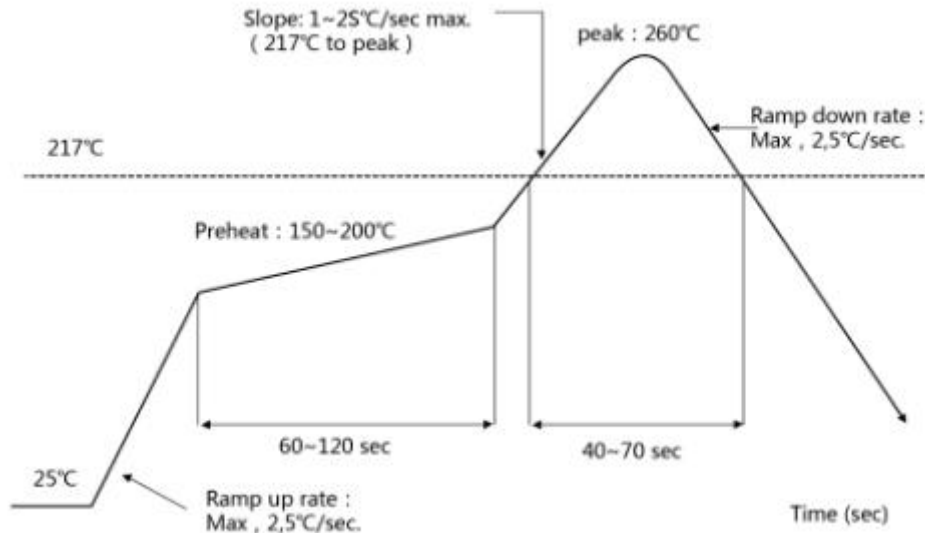

12. RoHS compliance

All hardware components are fully compliant with EU RoHS directive

13. Package

13.1 Reel

A roll of 1500pcs

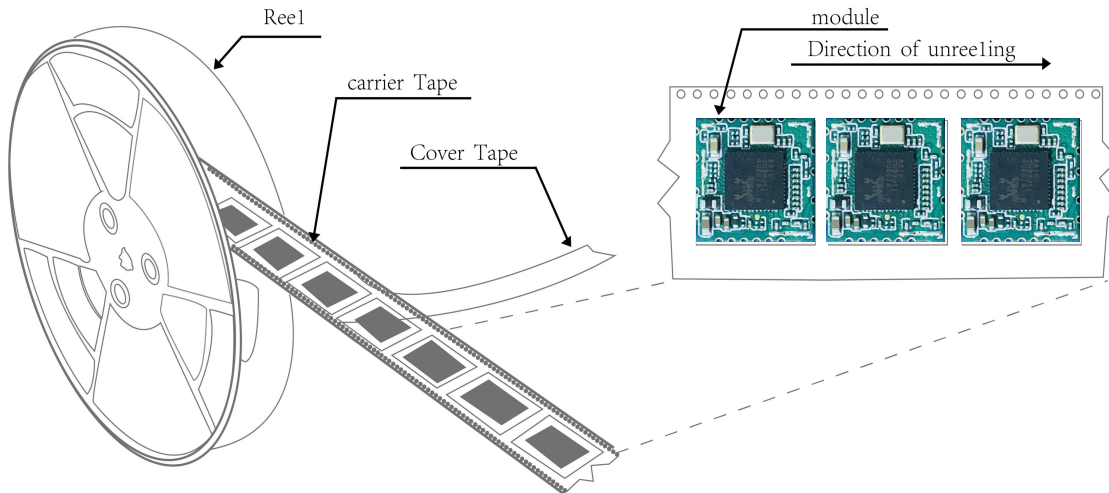

13.2 Carrier Tape Detail

ITEM	W	A0	B0	D	F	E	K0	P0	P2	P	T
DIM	24	12.50	13.35	1.50	11.5	1.75	2.5	4.0	2.0	16.0	0.30
TOLE	+0.3 -0.3	±0.15	±0.15	+0.1 -0.0	+0.1 -0.1	±0.1	±0.10	±0.1	±0.1	±0.1	±0.05

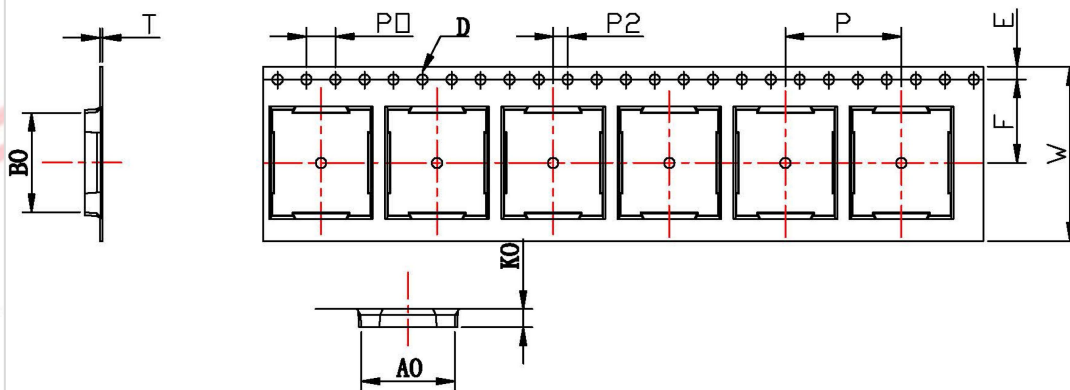

13.3 Packaging Detail

the take-up package



Using self-adhesive tape

Size of black tape: 24mm*32.6m the cover tape :21.3mm*32.6m

Color of plastic disc: blue



NY bag size:450mm*415mm



size : 350*350*35mm



The packing case size:360*210*370mmg

14. Moisture sensitivity

The Modules is a Moisture Sensitive Device level 3, in according with standard IPC/JEDEC J-STD-020, take care

all the relatives requirements for using this kind of components.

Moreover, the customer has to take care of the following conditions:

- a) Calculated shelf life in sealed bag: 12 months at <math><40^{\circ}\text{C}</math> and <math><90\%</math> relative humidity (RH)
- b) Environmental condition during the production: - c) The maximum time between the opening of the sealed bag and the reflow process must be 168 hours if condition
- b) "IPC/JEDEC J-STD-033A paragraph 5.2" is respected
- d) Baking is required if conditions b) or c) are not respected
- e) Baking is required if the humidity indicator inside the bag indicates 10% RH or more

单击下面可查看定价，库存，交付和生命周期等信息

[>>FN-LINK](#)